

Oracle® Spatial

Developer's Guide

11g Release 2 (11.2)

E11830-11

May 2012

Provides usage and reference information for indexing and storing spatial data and for developing spatial applications using Oracle Spatial and Oracle Locator.

Oracle Spatial Developer's Guide, 11g Release 2 (11.2)

E11830-11

Copyright © 1999, 2012, Oracle and/or its affiliates. All rights reserved.

Primary Author: Chuck Murray

Contributors: Dan Abugov, Nicole Alexander, Bruce Blackwell, Raja Chatterjee, Dan Geringer, Mike Horhammer, Ying Hu, Baris Kazar, Ravi Kothuri, Siva Ravada, Jack Wang, Ji Yang

This software and related documentation are provided under a license agreement containing restrictions on use and disclosure and are protected by intellectual property laws. Except as expressly permitted in your license agreement or allowed by law, you may not use, copy, reproduce, translate, broadcast, modify, license, transmit, distribute, exhibit, perform, publish, or display any part, in any form, or by any means. Reverse engineering, disassembly, or decompilation of this software, unless required by law for interoperability, is prohibited.

The information contained herein is subject to change without notice and is not warranted to be error-free. If you find any errors, please report them to us in writing.

If this is software or related documentation that is delivered to the U.S. Government or anyone licensing it on behalf of the U.S. Government, the following notice is applicable:

U.S. GOVERNMENT RIGHTS Programs, software, databases, and related documentation and technical data delivered to U.S. Government customers are "commercial computer software" or "commercial technical data" pursuant to the applicable Federal Acquisition Regulation and agency-specific supplemental regulations. As such, the use, duplication, disclosure, modification, and adaptation shall be subject to the restrictions and license terms set forth in the applicable Government contract, and, to the extent applicable by the terms of the Government contract, the additional rights set forth in FAR 52.227-19, Commercial Computer Software License (December 2007). Oracle America, Inc., 500 Oracle Parkway, Redwood City, CA 94065.

This software or hardware is developed for general use in a variety of information management applications. It is not developed or intended for use in any inherently dangerous applications, including applications that may create a risk of personal injury. If you use this software or hardware in dangerous applications, then you shall be responsible to take all appropriate fail-safe, backup, redundancy, and other measures to ensure its safe use. Oracle Corporation and its affiliates disclaim any liability for any damages caused by use of this software or hardware in dangerous applications.

Oracle and Java are registered trademarks of Oracle and/or its affiliates. Other names may be trademarks of their respective owners.

Intel and Intel Xeon are trademarks or registered trademarks of Intel Corporation. All SPARC trademarks are used under license and are trademarks or registered trademarks of SPARC International, Inc. AMD, Opteron, the AMD logo, and the AMD Opteron logo are trademarks or registered trademarks of Advanced Micro Devices. UNIX is a registered trademark of The Open Group.

This software or hardware and documentation may provide access to or information on content, products, and services from third parties. Oracle Corporation and its affiliates are not responsible for and expressly disclaim all warranties of any kind with respect to third-party content, products, and services. Oracle Corporation and its affiliates will not be responsible for any loss, costs, or damages incurred due to your access to or use of third-party content, products, or services.

Contents

Preface	xxvii
Audience	xxvii
Documentation Accessibility	xxvii
Related Documents	xxviii
Conventions	xxviii
What's New in Oracle Spatial?	xxix
Release 11.2	xxix
Release 11.1	xxx
Part I Conceptual and Usage Information	
1 Spatial Concepts	
1.1 What Is Oracle Spatial?	1-2
1.2 Object-Relational Model	1-2
1.3 Introduction to Spatial Data	1-3
1.4 Geometry Types	1-3
1.5 Data Model	1-4
1.5.1 Element	1-4
1.5.2 Geometry	1-5
1.5.3 Layer	1-5
1.5.4 Coordinate System	1-5
1.5.5 Tolerance	1-6
1.5.5.1 Tolerance in the Geometry Metadata for a Layer	1-7
1.5.5.2 Tolerance as an Input Parameter	1-7
1.6 Query Model	1-8
1.7 Indexing of Spatial Data	1-9
1.7.1 R-Tree Indexing	1-9
1.7.2 R-Tree Quality	1-10
1.8 Spatial Relationships and Filtering	1-10
1.9 Spatial Operators, Procedures, and Functions	1-13
1.10 Spatial Aggregate Functions	1-13
1.10.1 SDOAGGRTYPE Object Type	1-14
1.11 Three-Dimensional Spatial Objects	1-15
1.11.1 Modeling Surfaces	1-17

1.11.2	Modeling Solids	1-18
1.11.3	Three-Dimensional Optimized Rectangles	1-19
1.11.4	Using Texture Data.....	1-20
1.11.4.1	Schema Considerations with Texture Data	1-22
1.11.5	Validation Checks for Three-Dimensional Geometries	1-23
1.12	Geocoding	1-24
1.13	Spatial Java Application Programming Interface	1-24
1.14	Predefined User Accounts Created by Spatial.....	1-25
1.15	Performance and Tuning Information	1-26
1.16	OGC and ISO Compliance.....	1-26
1.17	Spatial Release (Version) Number.....	1-26
1.18	Moving Spatial Metadata (MDSYS.MOVE_SDO).....	1-27
1.19	Spatial Application Hardware Requirement Considerations	1-27
1.20	Spatial Error Messages	1-27
1.21	Spatial Examples	1-28
1.22	README File for Spatial and Related Features	1-28

2 Spatial Data Types and Metadata

2.1	Simple Example: Inserting, Indexing, and Querying Spatial Data.....	2-1
2.2	SDO_GEOMETRY Object Type	2-5
2.2.1	SDO_GTYPE.....	2-5
2.2.2	SDO_SRID.....	2-7
2.2.3	SDO_POINT	2-7
2.2.4	SDO_ELEM_INFO.....	2-7
2.2.5	SDO_ORDINATES	2-11
2.2.6	Usage Considerations	2-11
2.3	SDO_GEOMETRY Methods.....	2-12
2.4	SDO_GEOMETRY Constructors.....	2-13
2.5	TIN-Related Object Types.....	2-14
2.5.1	SDO_TIN Object Type.....	2-15
2.5.2	SDO_TIN_BLK_TYPE and SDO_TIN_BLK Object Types	2-18
2.6	Point Cloud-Related Object Types	2-18
2.6.1	SDO_PC Object Type	2-18
2.6.2	SDO_PC_BLK_TYPE and SDO_PC_BLK Object Type	2-20
2.7	Geometry Examples.....	2-20
2.7.1	Rectangle.....	2-20
2.7.2	Polygon with a Hole.....	2-21
2.7.3	Compound Line String	2-23
2.7.4	Compound Polygon	2-24
2.7.5	Point.....	2-25
2.7.6	Oriented Point.....	2-27
2.7.7	Type 0 (Zero) Element.....	2-29
2.7.8	Several Two-Dimensional Geometry Types	2-31
2.7.9	Three-Dimensional Geometry Types.....	2-35
2.8	Geometry Metadata Views	2-44
2.8.1	TABLE_NAME.....	2-45
2.8.2	COLUMN_NAME.....	2-45

2.8.3	DIMINFO	2-45
2.8.4	SRID	2-46
2.9	Spatial Index-Related Structures	2-46
2.9.1	Spatial Index Views	2-46
2.9.1.1	xxx_SDO_INDEX_INFO Views.....	2-46
2.9.1.2	xxx_SDO_INDEX_METADATA Views	2-47
2.9.2	Spatial Index Table Definition	2-49
2.9.3	R-Tree Index Sequence Object	2-49
2.10	Unit of Measurement Support	2-49
2.10.1	Creating a User-Defined Unit of Measurement	2-50

3 SQL Multimedia Type Support

3.1	ST_GEOMETRY and SDO_GEOMETRY Interoperability.....	3-1
3.2	ST_xxx Functions and Spatial Counterparts.....	3-7
3.3	Tolerance Value with SQL Multimedia Types	3-8
3.4	Avoiding Name Conflicts	3-8
3.5	Annotation Text Type and Views.....	3-8
3.5.1	Using the ST_ANNOTATION_TEXT Constructor.....	3-8
3.5.2	Annotation Text Metadata Views.....	3-9

4 Loading Spatial Data

4.1	Bulk Loading	4-1
4.1.1	Bulk Loading SDO_GEOMETRY Objects	4-1
4.1.2	Bulk Loading Point-Only Data in SDO_GEOMETRY Objects.....	4-3
4.2	Transactional Insert Operations Using SQL	4-3
4.3	Recommendations for Loading and Validating Spatial Data.....	4-4

5 Indexing and Querying Spatial Data

5.1	Creating a Spatial Index.....	5-1
5.1.1	Constraining Data to a Geometry Type.....	5-2
5.1.2	Creating a Cross-Schema Index.....	5-2
5.1.3	Using Partitioned Spatial Indexes	5-2
5.1.3.1	Creating a Local Partitioned Spatial Index	5-4
5.1.4	Exchanging Partitions Including Indexes	5-5
5.1.5	Export and Import Considerations with Spatial Indexes and Data	5-5
5.1.6	Distributed Transactions and Spatial Index Consistency	5-6
5.1.7	Rollback Segments and Sort Area Size	5-6
5.2	Querying Spatial Data	5-7
5.2.1	Spatial Query	5-7
5.2.1.1	Primary Filter Operator	5-8
5.2.1.2	Primary and Secondary Filter Operator.....	5-9
5.2.1.3	Within-Distance Operator	5-10
5.2.1.4	Nearest Neighbor Operator	5-11
5.2.1.5	Spatial Functions.....	5-12
5.2.2	Spatial Join	5-12
5.2.3	Data and Index Dimensionality, and Spatial Queries.....	5-13

6 Coordinate Systems (Spatial Reference Systems)

6.1	Terms and Concepts	6-1
6.1.1	Coordinate System (Spatial Reference System)	6-1
6.1.2	Cartesian Coordinates.....	6-2
6.1.3	Geodetic Coordinates (Geographic Coordinates).....	6-2
6.1.4	Projected Coordinates	6-2
6.1.5	Local Coordinates	6-2
6.1.6	Geodetic Datum	6-2
6.1.7	Transformation.....	6-2
6.2	Geodetic Coordinate Support	6-2
6.2.1	Geodesy and Two-Dimensional Geometry	6-3
6.2.2	Choosing a Geodetic or Projected Coordinate System.....	6-3
6.2.3	Choosing Non-Ellipsoidal or Ellipsoidal Height	6-3
6.2.3.1	Non-Ellipsoidal Height.....	6-4
6.2.3.2	Ellipsoidal Height.....	6-4
6.2.4	Geodetic MBRs.....	6-5
6.2.5	Other Considerations and Requirements with Geodetic Data	6-6
6.3	Local Coordinate Support.....	6-7
6.4	EPSG Model and Spatial	6-8
6.5	Three-Dimensional Coordinate Reference System Support.....	6-9
6.5.1	Geographic 3D Coordinate Reference Systems.....	6-10
6.5.2	Compound Coordinate Reference Systems	6-10
6.5.3	Three-Dimensional Transformations.....	6-11
6.5.4	Cross-Dimensionality Transformations	6-16
6.5.5	3D Equivalent for WGS 84?	6-16
6.6	TFM_PLAN Object Type	6-19
6.7	Coordinate Systems Data Structures.....	6-19
6.7.1	SDO_COORD_AXES Table	6-20
6.7.2	SDO_COORD_AXIS_NAMES Table	6-20
6.7.3	SDO_COORD_OP_METHODS Table	6-21
6.7.4	SDO_COORD_OP_PARAM_USE Table	6-21
6.7.5	SDO_COORD_OP_PARAM_VALS Table	6-22
6.7.6	SDO_COORD_OP_PARAMS Table.....	6-23
6.7.7	SDO_COORD_OP_PATHS Table	6-23
6.7.8	SDO_COORD_OPS Table.....	6-23
6.7.9	SDO_COORD_REF_SYS Table	6-25
6.7.10	SDO_COORD_REF_SYSTEM View	6-27
6.7.11	SDO_COORD_SYS Table	6-27
6.7.12	SDO_CRS_COMPOUND View	6-27
6.7.13	SDO_CRS_ENGINEERING View	6-28
6.7.14	SDO_CRS_GEOCENTRIC View	6-28
6.7.15	SDO_CRS_GEOGRAPHIC2D View.....	6-29
6.7.16	SDO_CRS_GEOGRAPHIC3D View.....	6-29
6.7.17	SDO_CRS_PROJECTED View	6-30
6.7.18	SDO_CRS_VERTICAL View	6-30
6.7.19	SDO_DATUM_ENGINEERING View	6-31
6.7.20	SDO_DATUM_GEODETTIC View	6-32

6.7.21	SDO_DATUM_VERTICAL View	6-32
6.7.22	SDO_DATUMS Table.....	6-33
6.7.23	SDO_ELLIPSOIDS Table	6-34
6.7.24	SDO_PREFERRED_OPS_SYSTEM Table.....	6-35
6.7.25	SDO_PREFERRED_OPS_USER Table	6-35
6.7.26	SDO_PRIME_MERIDIANS Table	6-36
6.7.27	SDO_UNITS_OF_MEASURE Table.....	6-36
6.7.28	Relationships Among Coordinate System Tables and Views.....	6-37
6.7.29	Finding Information About EPSG-Based Coordinate Systems.....	6-38
6.7.29.1	Geodetic Coordinate Systems.....	6-38
6.7.29.2	Projected Coordinate Systems	6-40
6.8	Legacy Tables and Views.....	6-42
6.8.1	MDSYS.CS_SRS Table	6-42
6.8.1.1	Well-Known Text (WKT).....	6-43
6.8.1.2	US-American and European Notations for Datum Parameters	6-45
6.8.1.3	Procedures for Updating the Well-Known Text	6-46
6.8.2	MDSYS.SDO_ANGLE_UNITS View	6-46
6.8.3	MDSYS.SDO_AREA_UNITS View	6-47
6.8.4	MDSYS.SDO_DATUMS_OLD_FORMAT and SDO_DATUMS_OLD_SNAPSHOT Tables 6-47	
6.8.5	MDSYS.SDO_DIST_UNITS View.....	6-49
6.8.6	MDSYS.SDO_ELLIPSOIDS_OLD_FORMAT and SDO_ELLIPSOIDS_OLD_ SNAPSHOT Tables 6-49	
6.8.7	MDSYS.SDO_PROJECTIONS_OLD_FORMAT and SDO_PROJECTIONS_OLD_ SNAPSHOT Tables 6-50	
6.9	Creating a User-Defined Coordinate Reference System	6-52
6.9.1	Creating a Geodetic CRS.....	6-52
6.9.2	Creating a Projected CRS.....	6-53
6.9.3	Creating a Vertical CRS.....	6-62
6.9.4	Creating a Compound CRS	6-63
6.9.5	Creating a Geographic 3D CRS.....	6-64
6.9.6	Creating a Transformation Operation	6-65
6.9.7	Using British Grid Transformation OSTN02/OSGM02 (EPSG Method 9633).....	6-67
6.10	Notes and Restrictions with Coordinate Systems Support.....	6-69
6.10.1	Different Coordinate Systems for Geometries with Operators and Functions	6-69
6.10.2	3D LRS Functions Not Supported with Geodetic Data.....	6-69
6.10.3	Functions Supported by Approximations with Geodetic Data	6-70
6.10.4	Unknown CRS and NaC Coordinate Reference Systems	6-70
6.11	U.S. National Grid Support	6-70
6.12	Google Maps Considerations.....	6-71
6.13	Example of Coordinate System Transformation	6-72

7 Linear Referencing System

7.1	Terms and Concepts	7-1
7.1.1	Geometric Segments (LRS Segments)	7-1
7.1.2	Shape Points	7-2
7.1.3	Direction of a Geometric Segment	7-2

7.1.4	Measure (Linear Measure).....	7-3
7.1.5	Offset.....	7-3
7.1.6	Measure Populating	7-3
7.1.7	Measure Range of a Geometric Segment.....	7-5
7.1.8	Projection	7-5
7.1.9	LRS Point.....	7-5
7.1.10	Linear Features.....	7-5
7.1.11	Measures with Multiline Strings and Polygons with Holes.....	7-5
7.2	LRS Data Model	7-6
7.3	Indexing of LRS Data.....	7-7
7.4	3D Formats of LRS Functions.....	7-7
7.5	LRS Operations.....	7-8
7.5.1	Defining a Geometric Segment	7-8
7.5.2	Redefining a Geometric Segment	7-8
7.5.3	Clipping a Geometric Segment.....	7-9
7.5.4	Splitting a Geometric Segment	7-9
7.5.5	Concatenating Geometric Segments	7-10
7.5.6	Scaling a Geometric Segment	7-11
7.5.7	Offsetting a Geometric Segment.....	7-12
7.5.8	Locating a Point on a Geometric Segment	7-12
7.5.9	Projecting a Point onto a Geometric Segment	7-13
7.5.10	Converting LRS Geometries.....	7-14
7.6	Tolerance Values with LRS Functions	7-15
7.7	Example of LRS Functions.....	7-15

8 Spatial Analysis and Mining

8.1	Spatial Information and Data Mining Applications	8-1
8.2	Spatial Binning for Detection of Regional Patterns.....	8-3
8.3	Materializing Spatial Correlation	8-3
8.4	Colocation Mining	8-4
8.5	Spatial Clustering.....	8-4
8.6	Location Prospecting	8-5

9 Extending Spatial Indexing Capabilities

9.1	SDO_GEOMETRY Objects in User-Defined Type Definitions	9-1
9.2	SDO_GEOMETRY Objects in Function-Based Indexes.....	9-3
9.2.1	Example: Function with Standard Types	9-3
9.2.2	Example: Function with a User-Defined Object Type.....	9-4

Part II Spatial Web Services

10 Introduction to Spatial Web Services

10.1	Types of Spatial Web Services.....	10-1
10.2	Types of Users of Spatial Web Services	10-2
10.3	Setting Up the Client for Spatial Web Services.....	10-2
10.4	Demo Files for Sample Java Client	10-6

11 Geocoding Address Data

11.1	Concepts for Geocoding.....	11-1
11.1.1	Address Representation.....	11-1
11.1.2	Match Modes	11-2
11.1.3	Match Codes	11-3
11.1.4	Error Messages for Output Geocoded Addresses	11-4
11.1.5	Match Vector for Output Geocoded Addresses.....	11-4
11.2	Data Types for Geocoding.....	11-5
11.2.1	SDO_GEO_ADDR Type	11-5
11.2.2	SDO_ADDR_ARRAY Type.....	11-8
11.2.3	SDO_KEYWORDARRAY Type.....	11-8
11.3	Using the Geocoding Capabilities	11-8
11.4	Geocoding from a Place Name.....	11-9
11.5	Data Structures for Geocoding.....	11-10
11.5.1	GC_ADDRESS_POINT_<suffix> Table and Index.....	11-11
11.5.2	GC_AREA_<suffix> Table	11-12
11.5.3	GC_COUNTRY_PROFILE Table.....	11-14
11.5.4	GC_INTERSECTION_<suffix> Table	11-15
11.5.5	GC_PARSER_PROFILES Table	11-16
11.5.6	GC_PARSER_PROFILEAFS Table	11-19
11.5.6.1	ADDRESS_FORMAT_STRING Description	11-20
11.5.7	GC_POI_<suffix> Table.....	11-22
11.5.8	GC_POSTAL_CODE_<suffix> Table.....	11-23
11.5.9	GC_ROAD_<suffix> Table.....	11-24
11.5.10	GC_ROAD_SEGMENT_<suffix> Table	11-26
11.5.11	Indexes on Tables for Geocoding	11-28
11.6	Installing the Profile Tables	11-29
11.7	Using the Geocoding Service (XML API).....	11-30
11.7.1	Deploying and Configuring the J2EE Geocoder	11-31
11.7.1.1	Configuring the geocodercfg.xml File.....	11-32
11.7.2	Geocoding Request XML Schema Definition and Example	11-33
11.7.3	Geocoding Response XML Schema Definition and Example	11-35

12 Business Directory (Yellow Pages) Support

12.1	Business Directory Concepts.....	12-1
12.2	Using the Business Directory Capabilities	12-1
12.3	Data Structures for Business Directory Support	12-2
12.3.1	OPENLS_DIR_BUSINESSES Table	12-2
12.3.2	OPENLS_DIR_BUSINESS_CHAINS Table.....	12-3
12.3.3	OPENLS_DIR_CATEGORIES Table.....	12-3
12.3.4	OPENLS_DIR_CATEGORIZATIONS Table	12-4
12.3.5	OPENLS_DIR_CATEGORY_TYPES Table	12-4
12.3.6	OPENLS_DIR_SYNONYMS Table	12-5

13 Routing Engine

13.1	Multi-Address Routing	13-2
------	-----------------------------	------

13.2	Deploying and Configuring the Routing Engine	13-3
13.2.1	Configuring the web.xml File	13-6
13.3	Routing Engine XML API	13-8
13.3.1	Route Request and Response Examples	13-9
13.3.2	Route Request DTD	13-14
13.3.2.1	route_request Element	13-16
13.3.2.2	route_request Attributes	13-16
13.3.2.3	input_location Element	13-18
13.3.2.4	pre_geocoded_location Element	13-18
13.3.3	Route Response DTD	13-19
13.3.4	Batch Route Request and Response Examples	13-19
13.3.5	Batch Route Request DTD	13-22
13.3.5.1	batch_route_request Element	13-23
13.3.5.2	batch_route_request Attributes	13-23
13.3.6	Batch Route Response DTD	13-24
13.4	Data Structures Used by the Routing Engine	13-24
13.4.1	EDGE Table	13-24
13.4.2	NODE Table	13-25
13.4.3	PARTITION Table	13-25
13.4.4	SIGN_POST Table	13-26

14 OpenLS Support

14.1	Supported OpenLS Services	14-1
14.2	OpenLS Application Programming Interfaces	14-2
14.3	OpenLS Service Support and Examples	14-2
14.3.1	OpenLS Geocoding	14-2
14.3.2	OpenLS Mapping	14-4
14.3.3	OpenLS Routing	14-6
14.3.4	OpenLS Directory Service (YP)	14-8

15 Web Feature Service (WFS) Support

15.1	WFS Engine	15-1
15.2	Managing Feature Types	15-2
15.2.1	Capabilities Documents	15-3
15.3	Request and Response XML Examples	15-4
15.4	Java API for WFS Administration	15-13
15.4.1	createXMLTableIndex method	15-13
15.4.2	dropFeatureType method	15-13
15.4.3	dropXMLTableIndex method	15-14
15.4.4	getIsXMLTableIndexCreated method	15-14
15.4.5	grantFeatureTypeToUser method	15-14
15.4.6	grantMDAccessToUser method	15-15
15.4.7	publishFeatureType method	15-15
15.4.7.1	Related Classes for publishFeatureType	15-19
15.4.8	revokeFeatureTypeFromUser method	15-23
15.4.9	revokeMDAccessFromUser method	15-23
15.4.10	setXMLTableIndexInfo method	15-23

15.5	Using WFS with Oracle Workspace Manager	15-24
16	Catalog Services for the Web (CSW) Support	
16.1	CSW Engine and Architecture	16-1
16.2	CSW APIs and Configuration	16-2
16.2.1	Capabilities Documents	16-3
16.2.2	Spatial Path Extractor Function (extractSDO)	16-3
16.2.2.1	Registering and Unregistering the extractSDO Function	16-5
16.3	Request and Response XML Examples.....	16-5
16.4	Java API for CSW Administration.....	16-15
16.4.1	createXMLTableIndex method	16-15
16.4.2	deleteDomainInfo method	16-15
16.4.3	deleteRecordViewMap method.....	16-16
16.4.4	disableVersioning method	16-16
16.4.5	dropRecordType method	16-16
16.4.6	dropXMLTableIndex method	16-17
16.4.7	enableVersioning method.....	16-17
16.4.8	getIsXMLTableIndexCreated method	16-17
16.4.9	getRecordTypeId method.....	16-17
16.4.10	grantMDAccessToUser method	16-18
16.4.11	grantRecordTypeToUser method.....	16-18
16.4.12	publishRecordType method.....	16-18
16.4.12.1	Related Classes for publishRecordType.....	16-22
16.4.13	registerTypePluginMap method	16-26
16.4.14	revokeMDAccessFromUser method.....	16-26
16.4.15	revokeRecordTypeFromUser method	16-26
16.4.16	setCapabilitiesInfo method	16-27
16.4.17	setDomainInfo method	16-27
16.4.18	setRecordViewMap method.....	16-27
16.4.19	setXMLTableIndexInfo method.....	16-28
17	Security Considerations for Spatial Web Services	
17.1	User Management.....	17-1
17.1.1	Identity Propagation to the Database	17-2
17.1.2	Caching and User Administration	17-2
17.2	Access Control and Versioning.....	17-3
17.2.1	Virtual Private Databases	17-3
17.2.2	Workspace Manager.....	17-3
17.3	Configuring Web Services for Security.....	17-4
17.3.1	Adding Spatial Service Handlers	17-5
17.4	Interfaces for Spatial Web Services.....	17-6
17.4.1	SOAP/WSS Interface	17-6
17.4.2	XML (Non-SOAP) Interface	17-6
17.4.3	PL/SQL Interface (OpenLS Only).....	17-7
17.4.4	Level of Security, by Interface.....	17-7

Part III Reference Information

18 SQL Statements for Indexing Spatial Data

ALTER INDEX	18-2
ALTER INDEX REBUILD	18-4
ALTER INDEX RENAME TO	18-7
CREATE INDEX.....	18-8
DROP INDEX	18-12

19 Spatial Operators

SDO_ANYINTERACT	19-3
SDO_CONTAINS	19-5
SDO_COVEREDBY	19-7
SDO_COVERS	19-9
SDO_EQUAL.....	19-11
SDO_FILTER.....	19-13
SDO_INSIDE	19-16
SDO_JOIN	19-18
SDO_NN	19-23
SDO_NN_DISTANCE.....	19-28
SDO_ON.....	19-30
SDO_OVERLAPBDYDISJOINT.....	19-32
SDO_OVERLAPBDYINTERSECT.....	19-34
SDO_OVERLAPS.....	19-36
SDO_RELATE.....	19-38
SDO_TOUCH	19-42
SDO_WITHIN_DISTANCE.....	19-44

20 Spatial Aggregate Functions

SDO_AGGR_CENTROID.....	20-2
SDO_AGGR_CONCAT_LINES.....	20-3
SDO_AGGR_CONVEXHULL.....	20-5
SDO_AGGR_LRS_CONCAT	20-6
SDO_AGGR_MBR	20-8
SDO_AGGR_SET_UNION.....	20-9
SDO_AGGR_UNION	20-11

21 SDO_CS Package (Coordinate System Transformation)

SDO_CS.ADD_PREFERENCE_FOR_OP	21-4
SDO_CS.CONVERT_NADCON_TO_XML	21-6
SDO_CS.CONVERT_NTV2_TO_XML	21-8

SDO_CS.CONVERT_XML_TO_NADCON	21-10
SDO_CS.CONVERT_XML_TO_NTV2	21-12
SDO_CS.CREATE_CONCATENATED_OP	21-14
SDO_CS.CREATE_OBVIOUS_EPSG_RULES	21-15
SDO_CS.CREATE_PREF_CONCATENATED_OP	21-16
SDO_CS.DELETE_ALL_EPSG_RULES	21-18
SDO_CS.DELETE_OP	21-19
SDO_CS.DETERMINE_CHAIN	21-20
SDO_CS.DETERMINE_DEFAULT_CHAIN	21-22
SDO_CS.FIND_GEOG_CRIS	21-23
SDO_CS.FIND_PROJ_CRIS	21-25
SDO_CS.FIND_SRID	21-27
SDO_CS.FROM_OGC_SIMPLEFEATURE_SRS	21-31
SDO_CS.FROM_USNG	21-32
SDO_CS.GET_EPSG_DATA_VERSION	21-33
SDO_CS.MAKE_2D	21-34
SDO_CS.MAKE_3D	21-35
SDO_CS.MAP_EPSG_SRID_TO_ORACLE	21-36
SDO_CS.MAP_ORACLE_SRID_TO_EPSG	21-37
SDO_CS.REVOKE_PREFERENCE_FOR_OP	21-38
SDO_CS.TO_OGC_SIMPLEFEATURE_SRS	21-39
SDO_CS.TO_USNG	21-40
SDO_CS.TRANSFORM	21-42
SDO_CS.TRANSFORM_LAYER	21-44
SDO_CS.UPDATE_WKTS_FOR_ALL_EPSG_CRIS	21-46
SDO_CS.UPDATE_WKTS_FOR_EPSG_CRIS	21-47
SDO_CS.UPDATE_WKTS_FOR_EPSG_DATUM	21-48
SDO_CS.UPDATE_WKTS_FOR_EPSG_ELLIPS	21-49
SDO_CS.UPDATE_WKTS_FOR_EPSG_OP	21-50
SDO_CS.UPDATE_WKTS_FOR_EPSG_PARAM	21-51
SDO_CS.UPDATE_WKTS_FOR_EPSG_PM	21-52
SDO_CS.VALIDATE_WKT	21-53

22 SDO_CSW_PROCESS Package (CSW Processing)

SDO_CSW_PROCESS.DeleteCapabilitiesInfo	22-2
SDO_CSW_PROCESS.DeleteDomainInfo	22-3
SDO_CSW_PROCESS.DeletePluginMap	22-4
SDO_CSW_PROCESS.DeleteRecordViewMap	22-5
SDO_CSW_PROCESS.GetRecordTypeId	22-6
SDO_CSW_PROCESS.InsertCapabilitiesInfo	22-7
SDO_CSW_PROCESS.InsertDomainInfo	22-8

SDO_CSW_PROCESS.InsertPluginMap	22-9
SDO_CSW_PROCESS.InsertRecordViewMap	22-10
SDO_CSW_PROCESS.InsertRtDataUpdated	22-12
SDO_CSW_PROCESS.InsertRtMDUpdated.....	22-13

23 SDO_GCDR Package (Geocoding)

SDO_GCDR.CREATE_PROFILE_TABLES.....	23-2
SDO_GCDR.GEOCODE	23-3
SDO_GCDR.GEOCODE_ADDR	23-4
SDO_GCDR.GEOCODE_ADDR_ALL	23-6
SDO_GCDR.GEOCODE_ALL	23-8
SDO_GCDR.GEOCODE_AS_GEOMETRY	23-10
SDO_GCDR.REVERSE_GEOCODE.....	23-11

24 SDO_GEOM Package (Geometry)

SDO_GEOM.RELATE	24-4
SDO_GEOM.SDO_ALPHA_SHAPE.....	24-7
SDO_GEOM.SDO_ARC_DENSIFY.....	24-9
SDO_GEOM.SDO_AREA	24-11
SDO_GEOM.SDO_BUFFER	24-13
SDO_GEOM.SDO_CENTROID	24-16
SDO_GEOM.SDO_CLOSEST_POINTS	24-18
SDO_GEOM.SDO_CONCAVEHULL	24-20
SDO_GEOM.SDO_CONCAVEHULL_BOUNDARY	24-22
SDO_GEOM.SDO_CONVEXHULL.....	24-24
SDO_GEOM.SDO_DIFFERENCE	24-26
SDO_GEOM.SDO_DISTANCE.....	24-28
SDO_GEOM.SDO_INTERSECTION	24-30
SDO_GEOM.SDO_LENGTH	24-32
SDO_GEOM.SDO_MAX_MBR_ORDINATE	24-34
SDO_GEOM.SDO_MBR	24-36
SDO_GEOM.SDO_MIN_MBR_ORDINATE	24-38
SDO_GEOM.SDO_POINTONSURFACE.....	24-40
SDO_GEOM.SDO_TRIANGULATE.....	24-42
SDO_GEOM.SDO_UNION	24-43
SDO_GEOM.SDO_VOLUME.....	24-45
SDO_GEOM.SDO_XOR.....	24-47
SDO_GEOM.VALIDATE_GEOMETRY_WITH_CONTEXT	24-49
SDO_GEOM.VALIDATE_LAYER_WITH_CONTEXT	24-53
SDO_GEOM.WITHIN_DISTANCE	24-56

25 SDO_LRS Package (Linear Referencing System)

SDO_LRS.CLIP_GEOM_SEGMENT	25-5
SDO_LRS.CONCATENATE_GEOM_SEGMENTS	25-7
SDO_LRS.CONNECTED_GEOM_SEGMENTS	25-10
SDO_LRS.CONVERT_TO_LRS_DIM_ARRAY	25-12
SDO_LRS.CONVERT_TO_LRS_GEOM	25-14
SDO_LRS.CONVERT_TO_LRS_LAYER	25-16
SDO_LRS.CONVERT_TO_STD_DIM_ARRAY	25-18
SDO_LRS.CONVERT_TO_STD_GEOM	25-19
SDO_LRS.CONVERT_TO_STD_LAYER	25-20
SDO_LRS.DEFINE_GEOM_SEGMENT	25-22
SDO_LRS.DYNAMIC_SEGMENT	25-25
SDO_LRS.FIND_LRS_DIM_POS	25-27
SDO_LRS.FIND_MEASURE	25-28
SDO_LRS.FIND_OFFSET	25-30
SDO_LRS.GEOM_SEGMENT_END_MEASURE	25-32
SDO_LRS.GEOM_SEGMENT_END_PT	25-33
SDO_LRS.GEOM_SEGMENT_LENGTH	25-34
SDO_LRS.GEOM_SEGMENT_START_MEASURE	25-35
SDO_LRS.GEOM_SEGMENT_START_PT	25-36
SDO_LRS.GET_MEASURE	25-37
SDO_LRS.GET_NEXT_SHAPE_PT	25-38
SDO_LRS.GET_NEXT_SHAPE_PT_MEASURE	25-40
SDO_LRS.GET_PREV_SHAPE_PT	25-42
SDO_LRS.GET_PREV_SHAPE_PT_MEASURE	25-44
SDO_LRS.IS_GEOM_SEGMENT_DEFINED	25-46
SDO_LRS.IS_MEASURE_DECREASING	25-47
SDO_LRS.IS_MEASURE_INCREASING	25-48
SDO_LRS.IS_SHAPE_PT_MEASURE	25-49
SDO_LRS.LOCATE_PT	25-51
SDO_LRS.LRS_INTERSECTION	25-53
SDO_LRS.MEASURE_RANGE	25-55
SDO_LRS.MEASURE_TO_PERCENTAGE	25-56
SDO_LRS.OFFSET_GEOM_SEGMENT	25-58
SDO_LRS.PERCENTAGE_TO_MEASURE	25-61
SDO_LRS.PROJECT_PT	25-63
SDO_LRS.REDEFINE_GEOM_SEGMENT	25-65
SDO_LRS.RESET_MEASURE	25-67
SDO_LRS.REVERSE_GEOMETRY	25-69
SDO_LRS.REVERSE_MEASURE	25-71
SDO_LRS.SCALE_GEOM_SEGMENT	25-73

	SDO_LRS.SET_PT_MEASURE	25-75
	SDO_LRS.SPLIT_GEOM_SEGMENT	25-78
	SDO_LRS.TRANSLATE_MEASURE	25-80
	SDO_LRS.VALID_GEOM_SEGMENT	25-82
	SDO_LRS.VALID_LRS_PT	25-83
	SDO_LRS.VALID_MEASURE	25-84
	SDO_LRS.VALIDATE_LRS_GEOMETRY	25-86
26	SDO_MIGRATE Package (Upgrading)	
	SDO_MIGRATE.TO_CURRENT	26-2
27	SDO_OLS Package (OpenLS)	
	SDO_OLS.MakeOpenLSClobRequest.....	27-2
	SDO_OLS.MakeOpenLSRequest	27-4
28	SDO_PC_PKG Package (Point Clouds)	
	SDO_PC_PKG.CLIP_PC	28-2
	SDO_PC_PKG.CREATE_PC	28-4
	SDO_PC_PKG.DROP_DEPENDENCIES.....	28-6
	SDO_PC_PKG.GET_PT_IDS	28-7
	SDO_PC_PKG.INIT	28-8
	SDO_PC_PKG.TO_GEOMETRY	28-11
29	SDO_SAM Package (Spatial Analysis and Mining)	
	SDO_SAM.AGGREGATES_FOR_GEOMETRY	29-3
	SDO_SAM.AGGREGATES_FOR_LAYER	29-5
	SDO_SAM.BIN_GEOMETRY	29-7
	SDO_SAM.BIN_LAYER.....	29-9
	SDO_SAM.COLOCATED_REFERENCE_FEATURES.....	29-11
	SDO_SAM.SIMPLIFY_GEOMETRY	29-13
	SDO_SAM.SIMPLIFY_LAYER	29-15
	SDO_SAM.SPATIAL_CLUSTERS.....	29-17
	SDO_SAM.TILED_AGGREGATES.....	29-18
	SDO_SAM.TILED_BINS	29-21
30	SDO_TIN_PKG Package (TINs)	
	SDO_TIN_PKG.CLIP_TIN	30-2
	SDO_TIN_PKG.CREATE_TIN.....	30-4
	SDO_TIN_PKG.DROP_DEPENDENCIES.....	30-6
	SDO_TIN_PKG.INIT	30-7
	SDO_TIN_PKG.TO_GEOMETRY	30-10

31 SDO_TUNE Package (Tuning)

SDO_TUNE.AVERAGE_MBR	31-2
SDO_TUNE.ESTIMATE_RTREE_INDEX_SIZE.....	31-4
SDO_TUNE.EXTENT_OF.....	31-7
SDO_TUNE.MIX_INFO	31-8
SDO_TUNE.QUALITY_DEGRADATION.....	31-10

32 SDO_UTIL Package (Utility)

SDO_UTIL.AFFINETRANSFORMS.....	32-4
SDO_UTIL.APPEND.....	32-10
SDO_UTIL.BEARING_TILT_FOR_POINTS.....	32-11
SDO_UTIL.CIRCLE_POLYGON	32-13
SDO_UTIL.CONCAT_LINES	32-15
SDO_UTIL.CONVERT_UNIT.....	32-17
SDO_UTIL.DROP_WORK_TABLES.....	32-18
SDO_UTIL.ELLIPSE_POLYGON.....	32-19
SDO_UTIL.EXTRACT	32-21
SDO_UTIL.EXTRACT_ALL	32-24
SDO_UTIL.EXTRACT3D.....	32-28
SDO_UTIL.EXTRUDE.....	32-30
SDO_UTIL.FROM_GML311GEOMETRY	32-33
SDO_UTIL.FROM_GMLGEOMETRY	32-35
SDO_UTIL.FROM_KMLGEOMETRY	32-37
SDO_UTIL.FROM_WKBGEOMETRY	32-39
SDO_UTIL.FROM_WKTGEOMETRY.....	32-41
SDO_UTIL.GETNUMELEM	32-43
SDO_UTIL.GETNUMVERTICES	32-44
SDO_UTIL.GETVERTICES.....	32-45
SDO_UTIL.INITIALIZE_INDEXES_FOR_TTS	32-47
SDO_UTIL.INTERIOR_POINT.....	32-49
SDO_UTIL.POINT_AT_BEARING	32-50
SDO_UTIL.POLYGONTOLINE	32-52
SDO_UTIL.PREPARE_FOR_TTS.....	32-53
SDO_UTIL.RECTIFY_GEOMETRY	32-54
SDO_UTIL.REMOVE_DUPLICATE_VERTICES.....	32-56
SDO_UTIL.REVERSE_LINestring.....	32-58
SDO_UTIL.SIMPLIFY	32-59
SDO_UTIL.TO_GML311GEOMETRY	32-62
SDO_UTIL.TO_GMLGEOMETRY	32-67
SDO_UTIL.TO_KMLGEOMETRY	32-73
SDO_UTIL.TO_WKBGEOMETRY	32-75

SDO_UTIL.TO_WKTGEOMETRY	32-77
SDO_UTIL.VALIDATE_WKBGEOMETRY	32-79
SDO_UTIL.VALIDATE_WKTGEOMETRY	32-81

33 SDO_WFS_LOCK Package (WFS)

SDO_WFS_LOCK.EnableDBTxns	33-2
SDO_WFS_LOCK.RegisterFeatureTable	33-3
SDO_WFS_LOCK.UnRegisterFeatureTable	33-4

34 SDO_WFS_PROCESS Package (WFS Processing)

SDO_WFS_PROCESS.DropFeatureType	34-3
SDO_WFS_PROCESS.DropFeatureTypes	34-4
SDO_WFS_PROCESS.GenCollectionProcs	34-5
SDO_WFS_PROCESS.GetFeatureTypeId	34-6
SDO_WFS_PROCESS.GrantFeatureTypeToUser	34-7
SDO_WFS_PROCESS.GrantMDAccessToUser	34-8
SDO_WFS_PROCESS.InsertCapabilitiesInfo	34-9
SDO_WFS_PROCESS.InsertFtDataUpdated	34-10
SDO_WFS_PROCESS.InsertFtMDUpdated	34-11
SDO_WFS_PROCESS.PopulateFeatureTypeXMLInfo	34-12
SDO_WFS_PROCESS.PublishFeatureType	34-13
SDO_WFS_PROCESS.RegisterMTableView	34-18
SDO_WFS_PROCESS.RevokeFeatureTypeFromUser	34-21
SDO_WFS_PROCESS.RevokeMDAccessFromUser	34-22
SDO_WFS_PROCESS.UnRegisterMTableView	34-23

Part IV Supplementary Information

A Installation, Compatibility, and Upgrade

A.1	Ensuring That GeoRaster Works Properly After an Installation or Upgrade	A-1
A.2	Index Maintenance Before and After an Upgrade (WFS and CSW)	A-1
A.3	Increasing the Size of Ordinate Arrays to Support Very Large Geometries	A-2

B Oracle Locator

B.1	Installing and Deinstalling Locator or Spatial Manually	B-4
-----	---	-----

C Complex Spatial Queries: Examples

C.1	Tables Used in the Examples	C-1
C.2	SDO_WITHIN_DISTANCE Examples	C-2
C.3	SDO_NN Examples	C-3
C.4	SDO_AGGR_UNION Example	C-5

D Loading ESRI Shapefiles into Spatial

D.1	Usage of the Shapefile Converter	D-1
D.2	Examples of the Shapefile Converter	D-2

Glossary

Index

List of Examples

1-1	Inserting Texture Coordinate Definitions	1-22
1-2	Creating Tables for Texture Coordinates, Textures, and Surfaces	1-23
2-1	Simple Example: Inserting, Indexing, and Querying Spatial Data.....	2-2
2-2	SDO_GEOMETRY Methods.....	2-12
2-3	SDO_GEOMETRY Constructors to Create Geometries	2-14
2-4	SDO_TIN Attribute in a Query	2-18
2-5	SDO_PC Attribute in a Query	2-20
2-6	SQL Statement to Insert a Rectangle	2-21
2-7	SQL Statement to Insert a Polygon with a Hole.....	2-22
2-8	SQL Statement to Insert a Compound Line String.....	2-24
2-9	SQL Statement to Insert a Compound Polygon	2-25
2-10	SQL Statement to Insert a Point-Only Geometry	2-26
2-11	Query for Point-Only Geometry Based on a Coordinate Value	2-26
2-12	SQL Statement to Insert an Oriented Point Geometry	2-28
2-13	SQL Statement to Insert an Oriented Multipoint Geometry	2-29
2-14	SQL Statement to Insert a Geometry with a Type 0 Element.....	2-30
2-15	SQL Statements to Insert Various Two-Dimensional Geometries.....	2-31
2-16	SQL Statements to Insert Three-Dimensional Geometries	2-35
2-17	Updating Metadata and Creating Indexes for 3-Dimensional Geometries.....	2-43
2-18	Creating and Using a User-Defined Unit of Measurement	2-51
3-1	Using the ST_GEOMETRY Type for a Spatial Column.....	3-2
3-2	Creating, Indexing, Storing, and Querying ST_GEOMETRY Data	3-2
3-3	Using the ST_ANNOTATION_TEXT Constructor	3-9
4-1	Control File for a Bulk Load of Cola Market Geometries	4-1
4-2	Control File for a Bulk Load of Polygons	4-2
4-3	Control File for a Bulk Load of Point-Only Data.....	4-3
4-4	Procedure to Perform a Transactional Insert Operation	4-4
4-5	PL/SQL Block Invoking a Procedure to Insert a Geometry	4-4
5-1	SDO_NN Query with Partitioned Spatial Index	5-4
5-2	Primary Filter with a Temporary Query Window	5-9
5-3	Primary Filter with a Transient Instance of the Query Window	5-9
5-4	Primary Filter with a Stored Query Window	5-9
5-5	Secondary Filter Using a Temporary Query Window	5-10
5-6	Secondary Filter Using a Stored Query Window	5-10
6-1	Using a Geodetic MBR	6-5
6-2	Three-Dimensional Datum Transformation	6-11
6-3	Transformation Between Geoidal And Ellipsoidal Height.....	6-13
6-4	Cross-Dimensionality Transformation	6-16
6-5	Creating a User-Defined Geodetic Coordinate Reference System	6-52
6-6	Inserting a Row into the SDO_COORD_SYS Table	6-53
6-7	Creating a User-Defined Projected Coordinate Reference System.....	6-54
6-8	Inserting a Row into the SDO_COORD_OPS Table	6-55
6-9	Inserting a Row into the SDO_COORD_OP_PARAM_VALS Table.....	6-55
6-10	Creating a User-Defined Projected CRS: Extended Example.....	6-57
6-11	Creating a Vertical Coordinate Reference System	6-62
6-12	Creating a Compound Coordinate Reference System.....	6-63
6-13	Creating a Geographic 3D Coordinate Reference System	6-64
6-14	Creating a Transformation Operation	6-65
6-15	Loading Offset Matrixes	6-66
6-16	Using British Grid Transformation OSTN02/OSGM02 (EPSG Method 9633)	6-68
6-17	Simplified Example of Coordinate System Transformation.....	6-72
6-18	Output of SELECT Statements in Coordinate System Transformation Example	6-75
7-1	Including LRS Measure Dimension in Spatial Metadata	7-6
7-2	Simplified Example: Highway	7-17

7-3	Simplified Example: Output of SELECT Statements	7-20
10-1	WSConfig.xml File	10-3
11-1	Geocoding, Returning Address Object and Specific Attributes.....	11-7
11-2	Geocoding from a Place Name and Country	11-9
11-3	Geocoding from a Place Name, Country, and Other Fields	11-10
11-4	XML Definition for the US Address Format	11-19
11-5	Required Indexes on Tables for Geocoding	11-28
11-6	<database> Element Definitions.....	11-32
11-7	Geocoding Request (XML API).....	11-35
11-8	Geocoding Response (XML API).....	11-37
13-1	Route Request with Specified Addresses	13-10
13-2	Route Response with Specified Addresses	13-10
13-3	Route Request with Specified Longitude/Latitude Points.....	13-12
13-4	Route Response with Specified Longitude/Latitude Points	13-12
13-5	Route Request with Previously Geocoded Locations.....	13-13
13-6	Route Response with Previously Geocoded Locations	13-14
13-7	Batch Route Request with Specified Addresses	13-19
13-8	Batch Route Response with Specified Addresses	13-20
13-9	Batch Route Request with Previously Geocoded Locations.....	13-21
13-10	Batch Route Response with Previously Geocoded Locations	13-22
14-1	OpenLS Geocoding Request.....	14-2
14-2	OpenLS Geocoding Response	14-3
14-3	OpenLS Mapping Request.....	14-4
14-4	OpenLS Mapping Response	14-5
14-5	OpenLS Routing Request.....	14-6
14-6	OpenLS Routing Response	14-7
14-7	OpenLS Directory Service (YP) Request.....	14-8
14-8	OpenLS Directory Service (YP) Response	14-9
15-1	GetCapabilities Request	15-4
15-2	GetCapabilities Response	15-4
15-3	DescribeFeatureType Request.....	15-7
15-4	DescribeFeatureType Response	15-7
15-5	GetFeature Request.....	15-8
15-6	GetFeature Response	15-8
15-7	GetFeatureWithLock Request	15-9
15-8	GetFeatureWithLock Response.....	15-10
15-9	LockFeature Request	15-10
15-10	LockFeature Response.....	15-10
15-11	Insert Request	15-11
15-12	Insert Response	15-11
15-13	Update Request	15-11
15-14	Update Response	15-12
15-15	Delete Request	15-12
15-16	Delete Response	15-13
16-1	GetCapabilities Request	16-5
16-2	GetCapabilities Response	16-6
16-3	DescribeRecord Request	16-9
16-4	DescribeRecord Response.....	16-9
16-5	GetRecords Request.....	16-11
16-6	GetRecords Response	16-12
16-7	GetDomain Request.....	16-12
16-8	GetDomain Response	16-12
16-9	GetRecordById Request.....	16-13
16-10	GetRecordById Response	16-13
16-11	Insert Request	16-13

16-12	Insert Response	16-14
16-13	Update Request	16-14
16-14	Update Response	16-14
16-15	Delete Request	16-15
16-16	Delete Response	16-15
C-1	Finding All Cities Within a Distance of a Highway	C-2
C-2	Finding All Highways Within a Distance of a City	C-2
C-3	Finding the Cities Nearest to a Highway	C-3
C-4	Finding the Cities Above a Specified Population Nearest to a Highway.....	C-4
C-5	Aggregate Union with Groupings for Many Rows	C-5

List of Figures

1-1	Geometric Types	1-4
1-2	Query Model.....	1-8
1-3	MBR Enclosing a Geometry.....	1-9
1-4	R-Tree Hierarchical Index on MBRs.....	1-9
1-5	The Nine-Intersection Model	1-11
1-6	Topological Relationships.....	1-12
1-7	Distance Buffers for Points, Lines, and Polygons.....	1-12
1-8	Tolerance in an Aggregate Union Operation.....	1-15
1-9	Frustum as Query Window for Spatial Objects.....	1-18
1-10	Faces and Textures.....	1-21
1-11	Texture Mapped to a Face	1-21
2-1	Areas of Interest for the Simple Example.....	2-2
2-2	Storage of TIN Data	2-16
2-3	Rectangle	2-20
2-4	Polygon with a Hole	2-21
2-5	Compound Line String.....	2-23
2-6	Compound Polygon	2-24
2-7	Point-Only Geometry	2-26
2-8	Oriented Point Geometry.....	2-28
2-9	Geometry with Type 0 (Zero) Element	2-30
5-1	Geometries with MBRs	5-8
5-2	Layer with a Query Window	5-8
7-1	Geometric Segment.....	7-2
7-2	Describing a Point Along a Segment with a Measure and an Offset	7-3
7-3	Measures, Distances, and Their Mapping Relationship.....	7-4
7-4	Measure Populating of a Geometric Segment	7-4
7-5	Measure Populating with Disproportional Assigned Measures	7-4
7-6	Linear Feature, Geometric Segments, and LRS Points	7-5
7-7	Creating a Geometric Segment	7-6
7-8	Defining a Geometric Segment	7-8
7-9	Redefining a Geometric Segment	7-9
7-10	Clipping, Splitting, and Concatenating Geometric Segments.....	7-9
7-11	Measure Assignment in Geometric Segment Operations.....	7-10
7-12	Segment Direction with Concatenation.....	7-11
7-13	Scaling a Geometric Segment.....	7-11
7-14	Offsetting a Geometric Segment.....	7-12
7-15	Locating a Point Along a Segment with a Measure and an Offset	7-12
7-16	Ambiguity in Location Referencing with Offsets.....	7-13
7-17	Multiple Projection Points	7-13
7-18	Conversion from Standard to LRS Line String.....	7-14
7-19	Segment for Clip Operation Affected by Tolerance.....	7-15
7-20	Simplified LRS Example: Highway.....	7-16
8-1	Spatial Mining and Oracle Data Mining.....	8-2
11-1	Basic Flow of Action with the Spatial Geocoding Service	11-30
13-1	Basic Flow of Action with the Spatial Routing Engine.....	13-2
15-1	Web Feature Service Architecture	15-2
16-1	CSW Architecture	16-2
24-1	Arc Tolerance.....	24-10
24-2	SDO_GEOM.SDO_DIFFERENCE	24-27
24-3	SDO_GEOM.SDO_INTERSECTION	24-31
24-4	SDO_GEOM.SDO_UNION	24-44
24-5	SDO_GEOM.SDO_XOR.....	24-48
25-1	Translating a Geometric Segment	25-80
32-1	Simplification of a Geometry	32-61

List of Tables

1-1	SDO_GEOMETRY Attributes for Three-Dimensional Geometries	1-15
1-2	Predefined User Accounts Created by Spatial.....	1-25
2-1	Valid SDO_GTYPE Values	2-6
2-2	Values and Semantics in SDO_ELEM_INFO.....	2-9
2-3	SDO_GEOMETRY Methods.....	2-12
2-4	SDO_TIN Type Attributes.....	2-15
2-5	Columns in the TIN Block Table.....	2-16
2-6	SDO_PC Type Attributes.....	2-18
2-7	Columns in the Point Cloud Block Table	2-19
2-8	Columns in the xxx_SDO_INDEX_INFO Views.....	2-46
2-9	Columns in the xxx_SDO_INDEX_METADATA Views	2-47
2-10	Columns in an R-Tree Spatial Index Data Table	2-49
2-11	SDO_UNITS_OF_MEASURE Table Entries for User-Defined Unit.....	2-50
3-1	ST_xxx Functions and Spatial Counterparts.....	3-7
3-2	Columns in the Annotation Text Metadata Views.....	3-10
5-1	Data and Index Dimensionality, and Query Support.....	5-13
6-1	SDO_COORD_AXES Table	6-20
6-2	SDO_COORD_AXIS_NAMES Table.....	6-21
6-3	SDO_COORD_OP_METHODS Table.....	6-21
6-4	SDO_COORD_OP_PARAM_USE Table	6-21
6-5	SDO_COORD_OP_PARAM_VALS Table	6-22
6-6	SDO_COORD_OP_PARAMS Table.....	6-23
6-7	SDO_COORD_OP_PATHS Table.....	6-23
6-8	SDO_COORD_OPS Table.....	6-24
6-9	SDO_COORD_REF_SYS Table	6-25
6-10	SDO_COORD_SYS Table.....	6-27
6-11	SDO_CRS_COMPOUND View	6-27
6-12	SDO_CRS_ENGINEERING View	6-28
6-13	SDO_CRS_GEOCENTRIC View.....	6-28
6-14	SDO_CRS_GEOGRAPHIC2D View.....	6-29
6-15	SDO_CRS_GEOGRAPHIC3D View.....	6-29
6-16	SDO_CRS_PROJECTED View	6-30
6-17	SDO_CRS_VERTICAL View	6-30
6-18	SDO_DATUM_ENGINEERING View	6-31
6-19	SDO_DATUM_GEODETIC View	6-32
6-20	SDO_DATUM_VERTICAL View	6-32
6-21	SDO_DATUMS Table.....	6-33
6-22	SDO_ELLIPSOIDS Table.....	6-34
6-23	SDO_PREFERRED_OPS_SYSTEM Table	6-35
6-24	SDO_PREFERRED_OPS_USER Table	6-36
6-25	SDO_PRIME_MERIDIANS Table	6-36
6-26	SDO_UNITS_OF_MEASURE Table.....	6-36
6-27	EPSG Table Names and Oracle Spatial Names	6-38
6-28	MDSYS.CS_SRS Table	6-43
6-29	MDSYS.SDO_ANGLE_UNITS View	6-46
6-30	SDO_AREA_UNITS View	6-47
6-31	MDSYS.SDO_DATUMS_OLD_FORMAT and SDO_DATUMS_OLD_SNAPSHOT Tables..	6-47
6-32	MDSYS.SDO_DIST_UNITS View.....	6-49
6-33	MDSYS.SDO_ELLIPSOIDS_OLD_FORMAT and SDO_ELLIPSOIDS_OLD_SNAPSHOT Tables	6-50
6-34	MDSYS.SDO_PROJECTIONS_OLD_FORMAT and SDO_PROJECTIONS_OLD_ SNAPSHOT Tables	6-51

7-1	Highway Features and LRS Counterparts	7-16
11-1	Attributes for Formal Address Representation	11-1
11-2	Match Modes for Geocoding Operations	11-2
11-3	Match Codes for Geocoding Operations	11-3
11-4	Geocoded Address Error Message Interpretation	11-4
11-5	Geocoded Address Match Vector Interpretation	11-5
11-6	SDO_GEO_ADDR Type Attributes.....	11-6
11-7	GC_ADDRESS_POINT_<suffix> Table.....	11-11
11-8	GC_AREA_<suffix> Table.....	11-12
11-9	GC_COUNTRY_PROFILE Table.....	11-14
11-10	GC_INTERSECTION_<suffix> Table.....	11-16
11-11	GC_PARSER_PROFILES Table.....	11-16
11-12	GC_PARSER_PROFILEAFS Table.....	11-19
11-13	GC_POI_<suffix> Table.....	11-22
11-14	GC_POSTAL_CODE_<suffix> Table.....	11-23
11-15	GC_ROAD_<suffix> Table.....	11-24
11-16	GC_ROAD_SEGMENT_<suffix> Table.....	11-27
12-1	OPENLS_DIR_BUSINESSES Table.....	12-2
12-2	OPENLS_DIR_BUSINESS_CHAINS Table.....	12-3
12-3	OPENLS_DIR_CATEGORIES Table.....	12-3
12-4	OPENLS_DIR_CATEGORIZATIONS Table.....	12-4
12-5	OPENLS_DIR_CATEGORY_TYPES Table.....	12-4
12-6	OPENLS_DIR_SYNONYMS Table.....	12-5
13-1	EDGE Table.....	13-24
13-2	NODE Table.....	13-25
13-3	PARTITION Table.....	13-25
13-4	SIGN_POST Table.....	13-26
14-1	Spatial OpenLS Services Dependencies.....	14-1
18-1	Spatial Index Creation and Usage Statements.....	18-1
19-1	Main Spatial Operators	19-1
19-2	Convenience Operators for SDO_RELATE Operations.....	19-1
19-3	params Keywords for the SDO_JOIN Operator.....	19-19
19-4	Keywords for the SDO_NN Param Parameter.....	19-23
20-1	Spatial Aggregate Functions	20-1
21-1	Subprograms for Coordinate System Transformation.....	21-1
21-2	Table to Hold Transformed Layer.....	21-45
22-1	Subprograms for CSW Processing Operations.....	22-1
23-1	Subprograms for Geocoding Address Data.....	23-1
24-1	Geometry Subprograms.....	24-1
25-1	Subprograms for Creating and Editing Geometric Segments.....	25-1
25-2	Subprograms for Querying and Validating Geometric Segments.....	25-2
25-3	Subprograms for Converting Geometric Segments.....	25-3
27-1	Subprograms for OpenLS Support.....	27-1
28-1	Point Cloud Subprograms	28-1
29-1	Subprograms for Spatial Analysis and Mining.....	29-1
30-1	TIN Subprograms	30-1
31-1	Tuning Subprograms.....	31-1
32-1	Spatial Utility Subprograms.....	32-1
33-1	Subprograms for WFS Support.....	33-1
34-1	Subprograms for WFS Processing Operations	34-1
34-2	Geometry Types and columnInfo Parameter Values (WFS 1.0.n).....	34-17
B-1	Spatial-Related Features Supported for Locator	B-2
B-2	Spatial Features Not Supported for Locator	B-3
B-3	Feature Availability with Standard or Enterprise Edition.....	B-4

Preface

Oracle Spatial Developer's Guide provides usage and reference information for indexing and storing spatial data and for developing spatial applications using Oracle Spatial and Oracle Locator.

Oracle Spatial requires the Enterprise Edition of Oracle Database 11g. It is a foundation for the deployment of enterprise-wide spatial information systems, and Web-based and wireless location-based applications requiring complex spatial data management. Oracle Locator is a feature of the Standard and Enterprise Editions of Oracle Database 11g. It offers a subset of Oracle Spatial capabilities (see [Appendix B](#) for a list of Locator features) typically required to support Internet and wireless service applications and partner-based geographic information system (GIS) solutions.

The Standard and Enterprise Editions of Oracle Database 11g have the same basic features. However, several advanced features, such as extended data types, are available only with the Enterprise Edition, and some of these features are optional. For example, to use Oracle Database 11g table partitioning, you must have the Enterprise Edition and the Partitioning Option.

For information about the differences between Oracle Database 11g Standard Edition and Oracle Database 11g Enterprise Edition and the features and options that are available to you, see *Oracle Database New Features Guide*.

Audience

This guide is intended for anyone who needs to store spatial data in an Oracle database.

Documentation Accessibility

For information about Oracle's commitment to accessibility, visit the Oracle Accessibility Program website at <http://www.oracle.com/pls/topic/lookup?ctx=acc&id=docacc>.

Access to Oracle Support

Oracle customers have access to electronic support through My Oracle Support. For information, visit <http://www.oracle.com/pls/topic/lookup?ctx=acc&id=info> or visit <http://www.oracle.com/pls/topic/lookup?ctx=acc&id=trs> if you are hearing impaired.

Related Documents

For more information, see the following documents:

- *Oracle Spatial GeoRaster Developer's Guide*
- *Oracle Spatial Topology and Network Data Models Developer's Guide*
- *Oracle Database SQL Language Reference*
- *Oracle Database Administrator's Guide*
- *Oracle Database Advanced Application Developer's Guide*
- *Oracle Database Error Messages* - Spatial messages are in the range of 13000 to 13499.
- *Oracle Database Performance Tuning Guide*
- *Oracle Database Utilities*
- *Oracle Database Advanced Replication*
- *Oracle Database Data Cartridge Developer's Guide*

Conventions

The following text conventions are used in this document:

Convention	Meaning
boldface	Boldface type indicates graphical user interface elements associated with an action, or terms defined in text or the glossary.
<i>italic</i>	Italic type indicates book titles, emphasis, or placeholder variables for which you supply particular values.
monospace	Monospace type indicates commands within a paragraph, URLs, code in examples, text that appears on the screen, or text that you enter.

What's New in Oracle Spatial?

This section describes new and changed Oracle Spatial features for Oracle Database Release 11.

Release 11.2

The following are new and changed features for Oracle Spatial 11g Release 2 (11.2).

Index Maintenance Required Before and After Upgrade for WFS and CSW Data

If you are using Spatial Web Feature Service (WFS) or Catalog Services for the Web (CSW) support, and if you have data from a previous release that was indexed using one or more SYS.XMLTABLEINDEX indexes, you must drop the associated indexes **before** the upgrade and re-create the indexes after the upgrade.

For more information, see [Section A.2](#).

New Spatial Aggregate Function

The following new spatial aggregate function has been added (spatial aggregate functions are documented in [Chapter 20](#)):

- [SDO_AGGR_SET_UNION](#)

New SDO_GEOM Subprograms

The following new subprograms have been added to the SDO_GEOM package, which is documented in [Chapter 24](#):

- [SDO_GEOM.SDO_ALPHA_SHAPE](#)
- [SDO_GEOM.SDO_CONCAVEHULL](#)
- [SDO_GEOM.SDO_CONCAVEHULL_BOUNDARY](#)
- [SDO_GEOM.SDO_TRIANGULATE](#)

New SDO_UTIL Subprograms

The following new subprograms have been added to the SDO_UTIL package, which is documented in [Chapter 32](#):

- [SDO_UTIL.INTERIOR_POINT](#)
- [SDO_UTIL.FROM_KMLGEOMETRY](#)
- [SDO_UTIL.TO_KMLGEOMETRY](#)

New SDO_WFS_LOCK Subprogram

The following new subprogram has been added to the SDO_WFS_LOCK package, which is documented in [Chapter 33](#):

- [SDO_WFS_LOCK.EnableDBTxns](#)

SDO_NN_DISTANCE Performance Improvement with FIRST_ROWS Hint

The implementation of the [SDO_NN_DISTANCE](#) ancillary operator has been changed to provide improved performance when you specify the FIRST_ROWS optimizer hint. For an example of using the FIRST_ROWS hint, see the [SDO_NN_DISTANCE](#) reference section in [Chapter 19](#).

Support for Google Maps with Spatial Applications

Support for Google Maps with Oracle Spatial applications has been enhanced. Effective with Release 11.2.0.2, you can specify the new SRID 3857 instead of SRID 3785, which is convenient because you do not need to declare an EPSG rule or specify the USE_SPHERICAL use case name in order to produce Google-compatible results. Another option (effective with Release 11.2.0.1 but less convenient than the preceding option) is to specify a use case name of USE_SPHERICAL with the [SDO_CS.TRANSFORM](#) function or the [SDO_CS.TRANSFORM_LAYER](#) procedure. Both of these options cause Spatial to use spherical math (used by Google Maps) instead of ellipsoidal math in its projections. For more information, see [Section 6.12, "Google Maps Considerations"](#).

Support for Workspace Manager with WFS

You can perform database transactions and Oracle Workspace Manager workspace maintenance operations in the same session with WFS transactions (WFS-T). In the previous release, only WFS queries from one or more workspaces were supported. For information about using WFS with Workspace Manager, see [Section 15.5](#).

Cross-Endian Operations Supported for Transportable Tablespaces Containing Spatial Indexes

For the [SDO_UTIL.INITIALIZE_INDEXES_FOR_TTS](#) procedure (documented in [Chapter 32](#)), transportable tablespaces containing spatial indexes are now supported across endian format platforms (big-endian to little-endian, or little-endian to big-endian). They were not supported in the previous release.

Support for Very Large Geometries (More Than 1,048,576 Ordinates)

A new script is available if you need to support geometries with more than 1,048,576 ordinates; however, using that script involves significant extra work, some database downtime, and some considerations and restrictions. For information, see [Section A.3](#).

SDO_UTIL.PREPARE_FOR_TTS Deprecated

Effective with Oracle Database Release 11.2, the [SDO_UTIL.PREPARE_FOR_TTS](#) procedure is deprecated. You do not need to call that procedure before performing a transportable tablespace export operation.

GC_ADDRESS_POINT Table

The GC_ADDRESS_POINT_<suffix> table (for example, GC_ADDRESS_POINT_US) stores the actual longitude, latitude coordinates for addresses. It therefore enables the Spatial Geocoder to provide more accurate location results when it is used. The GC_ADDRESS_POINT table is not required for geocoding; however, if this table exists, it is

automatically used by the Geocoder for improved results. This table and its associated index are described in [Section 11.5.1](#).

Release 11.1

The following are new and changed features for Oracle Spatial 11g Release 1 (11.1).

3-D Geometry Support

Oracle Spatial supports the creation and storage of three-dimensional geometry objects, as explained in [Section 1.11](#).

Enhanced Web Services Support: Business Directory, Web Feature Service, Catalog Services, and OpenLS

Expanded support is provided for spatial Web services. A Web service enables developers of Oracle Spatial applications to provide feature data and metadata to their application users over the Web. [Chapter 10](#) introduces the support for Web services and includes some overall requirements and considerations. The following chapters document new features that are supported through Web services:

- [Chapter 12, "Business Directory \(Yellow Pages\) Support"](#)
- [Chapter 14, "OpenLS Support"](#)
- [Chapter 15, "Web Feature Service \(WFS\) Support"](#)
- [Chapter 16, "Catalog Services for the Web \(CSW\) Support"](#)

Routing Engine Enhancements

The routing engine includes the following enhancements:

- Per-maneuver times and geometries
- Long ID support
- Edge ID support at both the route level and segment level
- Better generation of driving directions

The routing engine is described in [Chapter 13](#).

SQL Multimedia Types

Support for the SQL Multimedia spatial types (ST_XXX) has been enhanced. These types are specified in *ISO 13249-3, Information technology - Database languages - SQL Multimedia and Application Packages - Part 3: Spatial*. The Oracle Spatial support for these types is described in [Chapter 3](#).

Annotation Text

Oracle Spatial now supports annotation text as specified in the *OpenGIS Implementation Specification for Geographic information - Simple feature access - Part 1: Common architecture*. This support is described in [Section 3.5](#).

DEFAULT Geocoding Match Mode Equivalent to RELAX_POSTAL_CODE

The DEFAULT match mode for geocoding operations is now equivalent to the RELAX_POSTAL_CODE mode. In the previous release, it was equivalent to the RELAX_BASE_NAME mode. The match modes for geocoding operations are explained [Section 11.1.2](#).

New MatchVector Attribute for SDO_GEOADDR

`MatchVector` has been added as the last attribute for the `SDO_GEOADDR` object type. This attribute is a string that indicates how each address attribute has been matched against the data used for geocoding. The `MatchVector` attribute is listed in [Table 11-6](#) and is explained more fully in [Section 11.1.5](#).

SDO_GEOM.CLOSEST_POINTS Procedure

The new `SDO_GEOM.CLOSEST_POINTS` procedure (described in [Chapter 24](#)) computes the minimum distance between two geometries and the points (one on each geometry) that are the minimum distance apart.

SDO_UTIL.BEARING_TILT_FOR_POINTS Procedure

The new `SDO_UTIL.BEARING_TILT_FOR_POINTS` procedure (described in [Chapter 32](#)) computes the bearing and tilt from a start point to an end point.

Filtering by Distance with the SDO_NN Operator

You can use the `distance` keyword in the `param` parameter to the `SDO_NN` operator (described in [Chapter 19](#)) to limit the distance in the search for nearest neighbors (for example, `'distance=10 unit=mile'`).

Part I

Conceptual and Usage Information

This document has the following parts:

- Part I provides conceptual and usage information about Oracle Spatial.
- [Part II](#) provides conceptual and usage information about Oracle Spatial Web services.
- [Part III](#) provides reference information about Oracle Spatial operators, functions, and procedures.
- [Part IV](#) provides supplementary information (appendixes and a glossary).

Part I is organized for efficient learning about Oracle Spatial. It covers basic concepts and techniques first, and proceeds to more advanced material, such as coordinate systems, the linear referencing system, geocoding, and extending spatial indexing.

Part I contains the following chapters:

- [Chapter 1, "Spatial Concepts"](#)
- [Chapter 2, "Spatial Data Types and Metadata"](#)
- [Chapter 3, "SQL Multimedia Type Support"](#)
- [Chapter 4, "Loading Spatial Data"](#)
- [Chapter 5, "Indexing and Querying Spatial Data"](#)
- [Chapter 6, "Coordinate Systems \(Spatial Reference Systems\)"](#)
- [Chapter 7, "Linear Referencing System"](#)
- [Chapter 8, "Spatial Analysis and Mining"](#)
- [Chapter 9, "Extending Spatial Indexing Capabilities"](#)

Spatial Concepts

Oracle Spatial is an integrated set of functions and procedures that enables spatial data to be stored, accessed, and analyzed quickly and efficiently in an Oracle database.

Spatial data represents the essential location characteristics of real or conceptual objects as those objects relate to the real or conceptual space in which they exist.

This chapter contains the following major sections:

- [Section 1.1, "What Is Oracle Spatial?"](#)
- [Section 1.2, "Object-Relational Model"](#)
- [Section 1.3, "Introduction to Spatial Data"](#)
- [Section 1.4, "Geometry Types"](#)
- [Section 1.5, "Data Model"](#)
- [Section 1.6, "Query Model"](#)
- [Section 1.7, "Indexing of Spatial Data"](#)
- [Section 1.8, "Spatial Relationships and Filtering"](#)
- [Section 1.9, "Spatial Operators, Procedures, and Functions"](#)
- [Section 1.10, "Spatial Aggregate Functions"](#)
- [Section 1.11, "Three-Dimensional Spatial Objects"](#)
- [Section 1.12, "Geocoding"](#)
- [Section 1.13, "Spatial Java Application Programming Interface"](#)
- [Section 1.14, "Predefined User Accounts Created by Spatial"](#)
- [Section 1.15, "Performance and Tuning Information"](#)
- [Section 1.16, "OGC and ISO Compliance"](#)
- [Section 1.17, "Spatial Release \(Version\) Number"](#)
- [Section 1.18, "Moving Spatial Metadata \(MDSYS.MOVE_SDO\)"](#)
- [Section 1.19, "Spatial Application Hardware Requirement Considerations"](#)
- [Section 1.20, "Spatial Error Messages"](#)
- [Section 1.21, "Spatial Examples"](#)
- [Section 1.22, "README File for Spatial and Related Features"](#)

1.1 What Is Oracle Spatial?

Oracle Spatial, often referred to as Spatial, provides a SQL schema and functions that facilitate the storage, retrieval, update, and query of collections of spatial features in an Oracle database. Spatial consists of the following:

- A schema (MDSYS) that prescribes the storage, syntax, and semantics of supported geometric data types
- A spatial indexing mechanism
- Operators, functions, and procedures for performing area-of-interest queries, spatial join queries, and other spatial analysis operations
- Functions and procedures for utility and tuning operations
- Topology data model for working with data about nodes, edges, and faces in a topology (described in *Oracle Spatial Topology and Network Data Models Developer's Guide*).
- Network data model for representing capabilities or objects that are modeled as nodes and links in a network (described in *Oracle Spatial Topology and Network Data Models Developer's Guide*).
- GeoRaster, a feature that lets you store, index, query, analyze, and deliver GeoRaster data, that is, raster image and gridded data and its associated metadata (described in *Oracle Spatial GeoRaster Developer's Guide*).

The spatial component of a spatial feature is the geometric representation of its shape in some coordinate space. This is referred to as its **geometry**.

Caution: Do not modify any packages, tables, or other objects under the MDSYS schema. (The only exception is if you need to create a user-defined coordinate reference system, as explained in [Section 6.9](#).)

1.2 Object-Relational Model

Spatial supports the **object-relational** model for representing geometries. This model stores an entire geometry in the Oracle native spatial data type for vector data, SDO_GEOMETRY. An Oracle table can contain one or more SDO_GEOMETRY columns. The object-relational model corresponds to a "SQL with Geometry Types" implementation of spatial feature tables in the Open GIS ODBC/SQL specification for geospatial features.

The benefits provided by the object-relational model include:

- Support for many geometry types, including arcs, circles, compound polygons, compound line strings, and optimized rectangles
- Ease of use in creating and maintaining indexes and in performing spatial queries
- Index maintenance by the Oracle database
- Geometries modeled in a single column
- Optimal performance

1.3 Introduction to Spatial Data

Oracle Spatial is designed to make spatial data management easier and more natural to users of location-enabled applications and geographic information system (GIS) applications. Once spatial data is stored in an Oracle database, it can be easily manipulated, retrieved, and related to all other data stored in the database.

A common example of spatial data can be seen in a road map. A road map is a two-dimensional object that contains points, lines, and polygons that can represent cities, roads, and political boundaries such as states or provinces. A road map is a visualization of geographic information. The location of cities, roads, and political boundaries that exist on the surface of the Earth are projected onto a two-dimensional display or piece of paper, preserving the relative positions and relative distances of the rendered objects.

The data that indicates the Earth location (such as longitude and latitude) of these rendered objects is the spatial data. When the map is rendered, this spatial data is used to project the locations of the objects on a two-dimensional piece of paper. A GIS is often used to store, retrieve, and render this Earth-relative spatial data.

Types of spatial data (other than GIS data) that can be stored using Spatial include data from computer-aided design (CAD) and computer-aided manufacturing (CAM) systems. Instead of operating on objects on a geographic scale, CAD/CAM systems work on a smaller scale, such as for an automobile engine or printed circuit boards.

The differences among these systems are in the size and precision of the data, not the data's complexity. The systems might all involve the same number of data points. On a geographic scale, the location of a bridge can vary by a few tenths of an inch without causing any noticeable problems to the road builders, whereas if the diameter of an engine's pistons is off by a few tenths of an inch, the engine will not run.

In addition, the complexity of data is independent of the absolute scale of the area being represented. For example, a printed circuit board is likely to have many thousands of objects etched on its surface, containing in its small area information that may be more complex than the details shown on a road builder's blueprints.

These applications all store, retrieve, update, or query some collection of features that have both nonspatial and spatial attributes. Examples of nonspatial attributes are name, soil_type, landuse_classification, and part_number. The spatial attribute is a coordinate geometry, or vector-based representation of the shape of the feature.

1.4 Geometry Types

A **geometry** is an ordered sequence of vertices that are connected by straight line segments or circular arcs. The semantics of the geometry are determined by its type. Spatial supports several primitive types, and geometries composed of collections of these types, including two-dimensional:

- Points and point clusters
- Line strings
- *n*-point polygons
- Arc line strings (All arcs are generated as circular arcs.)
- Arc polygons
- Compound polygons
- Compound line strings

- Circles
- Optimized rectangles

Two-dimensional points are elements composed of two ordinates, X and Y, often corresponding to longitude and latitude. **Line strings** are composed of one or more pairs of points that define line segments. **Polygons** are composed of connected line strings that form a closed ring, and the area of the polygon is implied. For example, a point might represent a building location, a line string might represent a road or flight path, and a polygon might represent a state, city, zoning district, or city block.

Self-crossing polygons are not supported, although self-crossing line strings are supported. If a line string crosses itself, it does not become a polygon. A self-crossing line string does not have any implied area.

Figure 1–1 illustrates the geometric types.

Figure 1–1 Geometric Types

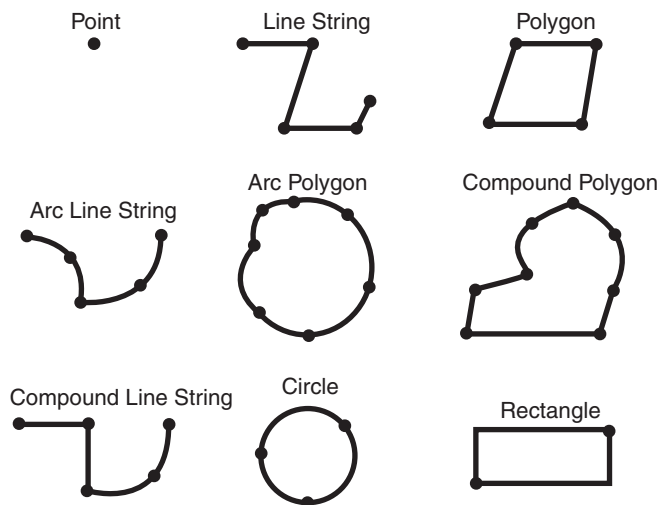

Spatial also supports the storage and indexing of three-dimensional and four-dimensional geometric types, where three or four coordinates are used to define each vertex of the object being defined. For information about support for three-dimensional geometries, see [Section 1.11](#).

1.5 Data Model

The Spatial data model is a hierarchical structure consisting of elements, geometries, and layers. Layers are composed of geometries, which in turn are made up of elements.

1.5.1 Element

An **element** is the basic building block of a geometry. The supported spatial element types are points, line strings, and polygons. For example, elements might model star constellations (point clusters), roads (line strings), and county boundaries (polygons). Each coordinate in an element is stored as an X,Y pair. The exterior ring and zero or more interior rings (holes) of a complex polygon are considered a single element.

Point data consists of one coordinate. **Line data** consists of two coordinates representing a line segment of the element. **Polygon data** consists of coordinate pair values, one vertex pair for each line segment of the polygon. Coordinates are defined in order around the polygon (counterclockwise for an exterior polygon ring, clockwise for an interior polygon ring).

1.5.2 Geometry

A **geometry** (or **geometry object**) is the representation of a spatial feature, modeled as an ordered set of primitive elements. A geometry can consist of a single element, which is an instance of one of the supported primitive types, or a homogeneous or heterogeneous collection of elements. A multipolygon, such as one used to represent a set of islands, is a homogeneous collection. A heterogeneous collection is one in which the elements are of different types, for example, a point and a polygon.

An example of a geometry might describe the buildable land in a town. This could be represented as a polygon with holes where water or zoning prevents construction.

1.5.3 Layer

A **layer** is a collection of geometries having the same attribute set. For example, one layer in a GIS might include topographical features, while another describes population density, and a third describes the network of roads and bridges in the area (lines and points). The geometries and associated spatial index for each layer are stored in the database in standard tables.

1.5.4 Coordinate System

A **coordinate system** (also called a *spatial reference system*) is a means of assigning coordinates to a location and establishing relationships between sets of such coordinates. It enables the interpretation of a set of coordinates as a representation of a position in a real world space.

Any spatial data has a coordinate system associated with it. The coordinate system can be *georeferenced* (related to a specific representation of the Earth) or not georeferenced (that is, Cartesian, and not related to a specific representation of the Earth). If the coordinate system is georeferenced, it has a default *unit of measurement* (such as meters) associated with it, but you can have Spatial automatically return results in another specified unit (such as miles). (For more information about unit of measurement support, see [Section 2.10](#).)

Spatial data can be associated with a Cartesian, geodetic (geographical), projected, or local coordinate system:

- **Cartesian coordinates** are coordinates that measure the position of a point from a defined origin along axes that are perpendicular in the represented two-dimensional or three-dimensional space.

If a coordinate system is not explicitly associated with a geometry, a Cartesian coordinate system is assumed.

- **Geodetic coordinates** (sometimes called *geographic coordinates*) are angular coordinates (longitude and latitude), closely related to spherical polar coordinates, and are defined relative to a particular Earth geodetic datum. (A geodetic datum is a means of representing the figure of the Earth and is the reference for the system of geodetic coordinates.)
- **Projected coordinates** are planar Cartesian coordinates that result from performing a mathematical mapping from a point on the Earth's surface to a

plane. There are many such mathematical mappings, each used for a particular purpose.

- **Local coordinates** are Cartesian coordinates in a non-Earth (non-georeferenced) coordinate system. Local coordinate systems are often used for CAD applications and local surveys.

When performing operations on geometries, Spatial uses either a Cartesian or curvilinear computational model, as appropriate for the coordinate system associated with the spatial data.

For more information about coordinate system support in Spatial, including geodetic, projected, and local coordinates and coordinate system transformation, see [Chapter 6](#).

1.5.5 Tolerance

Tolerance is used to associate a level of precision with spatial data. **Tolerance** reflects the *distance that two points can be apart and still be considered the same* (for example, to accommodate rounding errors). The tolerance value must be a positive number greater than zero. The significance of the value depends on whether or not the spatial data is associated with a geodetic coordinate system. (Geodetic and other types of coordinate systems are described in [Section 1.5.4](#).)

- For geodetic data (such as data identified by longitude and latitude coordinates), the tolerance value is a number of meters. For example, a tolerance value of 100 indicates a tolerance of 100 meters. The tolerance value for geodetic data should not be smaller than 0.05 (5 centimeters), and in most cases it should be larger. Spatial uses 0.05 as the tolerance value for geodetic data if you specify a smaller value with the following functions: [SDO_GEOM.RELATE](#), [SDO_GEOM.SDO_DIFFERENCE](#), [SDO_GEOM.SDO_INTERSECTION](#), [SDO_GEOM.SDO_UNION](#), and [SDO_GEOM.SDO_XOR](#); for other functions, Spatial uses the smaller tolerance value that you specify.
- For non-geodetic data, the tolerance value is a number of the units that are associated with the coordinate system associated with the data. For example, if the unit of measurement is miles, a tolerance value of 0.005 indicates a tolerance of 0.005 (that is, 1/200) mile (approximately 26 feet or 7.9 meters), and a tolerance value of 2 indicates a tolerance of 2 miles.

In both cases, the smaller the tolerance value, the more precision is to be associated with the data.

For geometries that have 16 or more digits of precision, Spatial boolean operations (such as [SDO_GEOM.SDO_UNION](#) and [SDO_GEOM.SDO_INTERSECTION](#)) and the [SDO_GEOM.RELATE](#) function might produce inconsistent results due to the loss of precision in floating point arithmetic. The number of digits of precision is calculated as in the following example: if the tolerance is set to 0.0000000005 and the coordinates have 6 digits to the left of decimal (for example, 123456.4321), the precision is 10 + 6 digits (16). In such cases, it is better to use a larger tolerance value (fewer leading zeros after the decimal) to get consistent results using Spatial operations.

A tolerance value is specified in two cases:

- In the geometry metadata definition for a layer (see [Section 1.5.5.1](#))
- As an input parameter to certain functions (see [Section 1.5.5.2](#))

For additional information about tolerance with linear referencing system (LRS) data, see [Section 7.6](#).

1.5.5.1 Tolerance in the Geometry Metadata for a Layer

The dimensional information for a layer includes a tolerance value. Specifically, the DIMINFO column (described in [Section 2.8.3](#)) of the xxx_SDO_GEOM_METADATA views includes an SDO_TOLERANCE value for each dimension, and the value should be the same for each dimension.

If a function accepts an optional `tolerance` parameter and this parameter is null or not specified, the SDO_TOLERANCE value of the layer is used. Using the non-geodetic data from the example in [Section 2.1](#), the actual distance between geometries `cola_b` and `cola_d` is 0.846049894. If a query uses the [SDO_GEOM.SDO_DISTANCE](#) function to return the distance between `cola_b` and `cola_d` and does not specify a `tolerance` parameter value, the result depends on the SDO_TOLERANCE value of the layer. For example:

- If the SDO_TOLERANCE value of the layer is 0.005, this query returns .846049894.
- If the SDO_TOLERANCE value of the layer is 0.5, this query returns 0.

The zero result occurs because Spatial first constructs an imaginary buffer of the tolerance value (0.5) around each geometry to be considered, and the buffers around `cola_b` and `cola_d` overlap in this case.

You can, therefore, take either of two approaches in selecting an SDO_TOLERANCE value for a layer:

- The value can reflect the desired level of precision in queries for distances between objects. For example, if two non-geodetic geometries 0.8 units apart should be considered as separated, specify a small SDO_TOLERANCE value such as 0.05 or smaller.
- The value can reflect the precision of the values associated with geometries in the layer. For example, if all geometries in a non-geodetic layer are defined using integers and if two objects 0.8 units apart should not be considered as separated, an SDO_TOLERANCE value of 0.5 is appropriate. To have greater precision in any query, you must override the default by specifying the `tolerance` parameter.

With non-geodetic data, the guideline to follow for most instances of the second case (precision of the values of the geometries in the layer) is: take the highest level of precision in the geometry definitions, and use .5 at the next level as the SDO_TOLERANCE value. For example, if geometries are defined using integers (as in the simplified example in [Section 2.1](#)), the appropriate value is 0.5; however, if geometries are defined using numbers up to four decimal positions (for example, 31.2587), the appropriate value is 0.00005.

Note: This guideline should not be used if the geometries include any polygons that are so narrow at any point that the distance between facing sides is less than the proposed tolerance value. Be sure that the tolerance value is less than the shortest distance between any two sides in any polygon.

Moreover, if you encounter "invalid geometry" errors with inserted or updated geometries, and if the geometries are in fact valid, consider increasing the precision of the tolerance value (for example, changing 0.00005 to 0.000005).

1.5.5.2 Tolerance as an Input Parameter

Many Spatial functions accept a `tolerance` parameter, which (if specified) overrides the default tolerance value for the layer (explained in [Section 1.5.5.1](#)). If the distance

between two points is less than or equal to the tolerance value, Spatial considers the two points to be a single point. Thus, tolerance is usually a reflection of how accurate or precise users perceive their spatial data to be.

For example, assume that you want to know which restaurants are within 5 kilometers of your house. Assume also that Maria's Pizzeria is 5.1 kilometers from your house. If the spatial data has a geodetic coordinate system and if you ask, *Find all restaurants within 5 kilometers and use a tolerance of 100* (or greater, such as 500), Maria's Pizzeria will be included, because 5.1 kilometers (5100 meters) is within 100 meters of 5 kilometers (5000 meters). However, if you specify a tolerance less than 100 (such as 50), Maria's Pizzeria will not be included.

Tolerance values for Spatial functions are typically very small, although the best value in each case depends on the kinds of applications that use or will use the data. See also the tolerance guidelines in [Section 1.5.5.1](#), and ensure that all input geometries are valid. (Spatial functions may not work as expected if the geometry data is not valid.)

1.6 Query Model

Spatial uses a **two-tier query model** to resolve spatial queries and spatial joins. The term is used to indicate that two distinct operations are performed to resolve queries. The output of the two combined operations yields the exact result set.

The two operations are referred to as *primary* and *secondary* filter operations.

- The **primary filter** permits fast selection of candidate records to pass along to the secondary filter. The primary filter compares geometry approximations to reduce computation complexity and is considered a lower-cost filter. Because the primary filter compares geometric approximations, it returns a superset of the exact result set.
- The **secondary filter** applies exact computations to geometries that result from the primary filter. The secondary filter yields an accurate answer to a spatial query. The secondary filter operation is computationally expensive, but it is only applied to the primary filter results, not the entire data set.

[Figure 1–2](#) illustrates the relationship between the primary and secondary filters.

Figure 1–2 Query Model

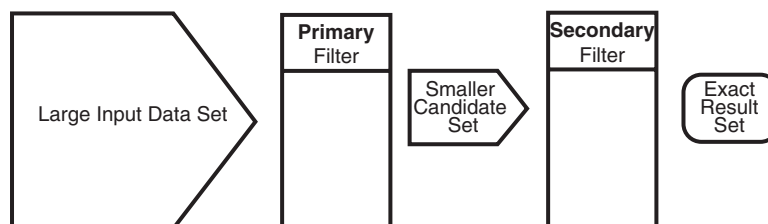

As shown in [Figure 1–2](#), the primary filter operation on a large input data set produces a smaller candidate set, which contains at least the exact result set and may contain more records. The secondary filter operation on the smaller candidate set produces the exact result set.

Spatial uses a spatial index to implement the primary filter. Spatial does not require the use of both the primary and secondary filters. In some cases, just using the primary filter is sufficient. For example, a *zoom* feature in a mapping application queries for

data that has any interaction with a rectangle representing visible boundaries. The primary filter very quickly returns a superset of the query. The mapping application can then apply clipping routines to display the target area.

The purpose of the primary filter is to quickly create a subset of the data and reduce the processing burden on the secondary filter. The primary filter, therefore, should be as efficient (that is, selective yet fast) as possible. This is determined by the characteristics of the spatial index on the data.

For more information about querying spatial data, see [Section 5.2](#).

1.7 Indexing of Spatial Data

The introduction of spatial indexing capabilities into the Oracle database engine is a key feature of the Spatial product. A spatial index, like any other index, provides a mechanism to limit searches, but in this case the mechanism is based on spatial criteria such as intersection and containment. A spatial index is needed to:

- Find objects within an indexed data space that interact with a given point or area of interest (window query)
- Find pairs of objects from within two indexed data spaces that interact spatially with each other (spatial join)

Testing of spatial indexes with many workloads and operators is ongoing, and results and recommendations will be documented as they become available.

The following sections explain the concepts and options associated with R-tree indexing.

1.7.1 R-Tree Indexing

A spatial R-tree index can index spatial data of up to four dimensions. An R-tree index approximates each geometry by a single rectangle that minimally encloses the geometry (called the minimum bounding rectangle, or MBR), as shown in [Figure 1–3](#).

Figure 1–3 MBR Enclosing a Geometry

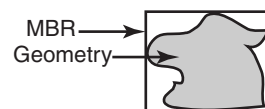

For a layer of geometries, an R-tree index consists of a hierarchical index on the MBRs of the geometries in the layer, as shown in [Figure 1–4](#).

Figure 1–4 R-Tree Hierarchical Index on MBRs

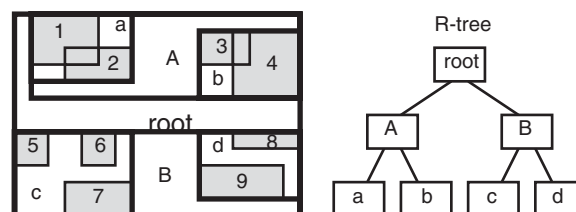

In [Figure 1–4](#):

- 1 through 9 are geometries in a layer.
- *a*, *b*, *c*, and *d* are the leaf nodes of the R-tree index, and contain minimum bounding rectangles of geometries, along with pointers to the geometries. For example, *a* contains the MBR of geometries 1 and 2, *b* contains the MBR of geometries 3 and 4, and so on.
- *A* contains the MBR of *a* and *b*, and *B* contains the MBR of *c* and *d*.
- The root contains the MBR of *A* and *B* (that is, the entire area shown).

An R-tree index is stored in the spatial index table (SDO_INDEX_TABLE in the USER_SDO_INDEX_METADATA view, described in [Section 2.9](#)). The R-tree index also maintains a sequence object (SDO_RTREE_SEQ_NAME in the USER_SDO_INDEX_METADATA view) to ensure that simultaneous updates by concurrent users can be made to the index.

1.7.2 R-Tree Quality

A substantial number of insert and delete operations affecting an R-tree index may degrade the quality of the R-tree structure, which may adversely affect query performance.

The R-tree is a hierarchical tree structure with nodes at different heights of the tree. The performance of an R-tree index structure for queries is roughly proportional to the area and perimeter of the index nodes of the R-tree. The area covered at level 0 represents the area occupied by the minimum bounding rectangles of the data geometries, the area at level 1 indicates the area covered by leaf-level R-tree nodes, and so on. The original ratio of the area at the root (topmost level) to the area at level 0 can change over time based on updates to the table; and if there is a degradation in that ratio (that is, if it increases significantly), rebuilding the index may help the performance of queries.

If the performance of [SDO_FILTER](#) operations has degraded, and if there have been a large number of insert, update, or delete operations affecting geometries, the performance degradation may be due to a degradation in the quality of the associated R-tree index. You can check for degradation of index quality by using the [SDO_TUNE.QUALITY_DEGRADATION](#) function (described in [Chapter 31](#)); and if the function returns a number greater than 2, consider rebuilding the index. Note, however, that the R-tree index quality degradation number may not be significant in terms of overall query performance due to Oracle caching strategies and other significant Oracle capabilities, such as table pinning, which can essentially remove I/O overhead from R-tree index queries.

To rebuild an R-tree index, use the [ALTER INDEX REBUILD](#) statement, which is described in [Chapter 18](#).

1.8 Spatial Relationships and Filtering

Spatial uses secondary filters to determine the spatial relationship between entities in the database. The spatial relationship is based on geometry locations. The most common spatial relationships are based on topology and distance. For example, the *boundary* of an area consists of a set of curves that separates the area from the rest of the coordinate space. The *interior* of an area consists of all points in the area that are not on its boundary. Given this, two areas are said to be adjacent if they share part of a boundary but do not share any points in their interior.

The distance between two spatial objects is the minimum distance between any points in them. Two objects are said to be *within a given distance* of one another if their distance is less than the given distance.

To determine spatial relationships, Spatial has several secondary filter methods:

- The [SDO_RELATE](#) operator evaluates topological criteria.
- The [SDO_WITHIN_DISTANCE](#) operator determines if two spatial objects are within a specified distance of each other.
- The [SDO_NN](#) operator identifies the nearest neighbors for a spatial object.

The syntax of these operators is given in [Chapter 19](#).

The [SDO_RELATE](#) operator implements a nine-intersection model for categorizing binary topological relationships between points, lines, and polygons. Each spatial object has an interior, a boundary, and an exterior. The boundary consists of points or lines that separate the interior from the exterior. The boundary of a line string consists of its end points; however, if the end points overlap (that is, if they are the same point), the line string has no boundary. The boundaries of a multiline string are the end points of each of the component line strings; however, if the end points overlap, only the end points that overlap an odd number of times are boundaries. The boundary of a polygon is the line that describes its perimeter. The interior consists of points that are in the object but not on its boundary, and the exterior consists of those points that are not in the object.

Given that an object A has three components (a boundary A_b , an interior A_i , and an exterior A_e), any pair of objects has nine possible interactions between their components. Pairs of components have an empty (0) or not empty (1) set intersection. The set of interactions between two geometries is represented by a nine-intersection matrix that specifies which pairs of components intersect and which do not. [Figure 1-5](#) shows the nine-intersection matrix for two polygons that are adjacent to one another. This matrix yields the following bit mask, generated in row-major form: "101001111".

Figure 1-5 The Nine-Intersection Model

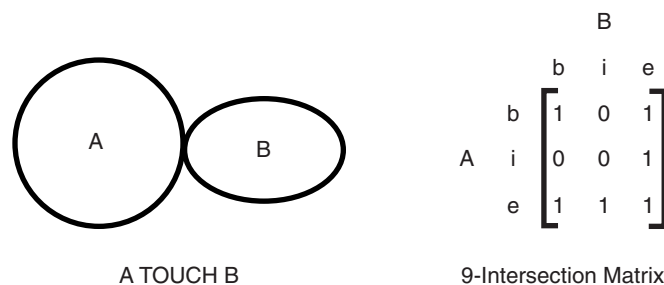

Some of the topological relationships identified in the seminal work by Professor Max Egenhofer (University of Maine, Orono) and colleagues have names associated with them. Spatial uses the following names:

- **DISJOINT**: The boundaries and interiors do not intersect.
- **TOUCH**: The boundaries intersect but the interiors do not intersect.
- **OVERLAPBDYDISJOINT**: The interior of one object intersects the boundary and interior of the other object, but the two boundaries do not intersect. This relationship occurs, for example, when a line originates outside a polygon and ends inside that polygon.

- **OVERLAPBDYINTERSECT**: The boundaries and interiors of the two objects intersect.
- **EQUAL**: The two objects have the same boundary and interior.
- **CONTAINS**: The interior and boundary of one object is completely contained in the interior of the other object.
- **COVERS**: The interior of one object is completely contained in the interior or the boundary of the other object and their boundaries intersect.
- **INSIDE**: The opposite of **CONTAINS**. A **INSIDE** B implies B **CONTAINS** A.
- **COVEREDBY**: The opposite of **COVERS**. A **COVEREDBY** B implies B **COVERS** A.
- **ON**: The interior and boundary of one object is on the boundary of the other object. This relationship occurs, for example, when a line is on the boundary of a polygon.
- **ANYINTERACT**: The objects are non-disjoint.

Figure 1–6 illustrates these topological relationships.

Figure 1–6 Topological Relationships

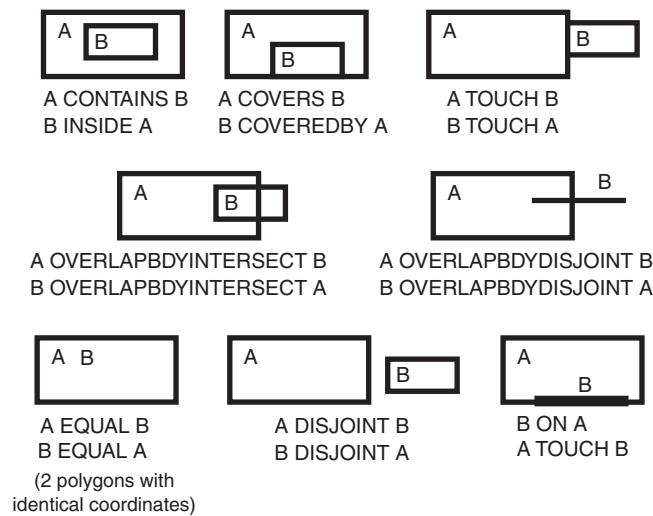

The **SDO_WITHIN_DISTANCE** operator determines if two spatial objects, A and B, are within a specified distance of one another. This operator first constructs a distance buffer, D_b , around the reference object B. It then checks that A and D_b are non-disjoint. The distance buffer of an object consists of all points within the given distance from that object. Figure 1–7 shows the distance buffers for a point, a line, and a polygon.

Figure 1–7 Distance Buffers for Points, Lines, and Polygons



In the point, line, and polygon geometries shown in Figure 1–7:

- The dashed lines represent distance buffers. Notice how the buffer is rounded near the corners of the objects.
- The geometry on the right is a polygon with a hole: the large rectangle is the exterior polygon ring and the small rectangle is the interior polygon ring (the hole). The dashed line outside the large rectangle is the buffer for the exterior ring, and the dashed line inside the small rectangle is the buffer for the interior ring.

The [SDO_NN](#) operator returns a specified number of objects from a geometry column that are closest to a specified geometry (for example, the five closest restaurants to a city park). In determining how close two geometry objects are, the shortest possible distance between any two points on the surface of each object is used.

1.9 Spatial Operators, Procedures, and Functions

The Spatial PL/SQL application programming interface (API) includes several operators and many procedures and functions.

Spatial operators, such as [SDO_FILTER](#) and [SDO_RELATE](#), provide optimum performance because they use the spatial index. (Spatial operators require that the geometry column in the first parameter have a spatial index defined on it.) Spatial operators must be used in the WHERE clause of a query. The first parameter of any operator specifies the geometry column to be searched, and the second parameter specifies a query window. If the query window does not have the same coordinate system as the geometry column, Spatial performs an implicit coordinate system transformation. For detailed information about the spatial operators, see [Chapter 19](#).

Spatial procedures and functions are provided as subprograms in PL/SQL packages, such as [SDO_GEOM](#), [SDO_CS](#), and [SDO_LRS](#). These subprograms do not require that a spatial index be defined, and they do not use a spatial index if it is defined. These subprograms can be used in the WHERE clause or in a subquery. If two geometries are input parameters to a Spatial procedure or function, both must have the same coordinate system.

The following performance-related guidelines apply to the use of spatial operators, procedures, and functions:

- If an operator and a procedure or function perform comparable operations, and if the operator satisfies your requirements, use the operator. For example, unless you need to do otherwise, use [SDO_RELATE](#) instead of [SDO_GEOM.RELATE](#), and use [SDO_WITHIN_DISTANCE](#) instead of [SDO_GEOM.WITHIN_DISTANCE](#).
- With operators, always specify TRUE in uppercase. That is, specify = 'TRUE', and do not specify <> 'FALSE' or = 'true'.
- With operators, use the /*+ ORDERED */ optimizer hint if the query window comes from a table. (You must use this hint if multiple windows come from a table.) See the Usage Notes and Examples for specific operators for more information.

For information about using operators with topologies, see *Oracle Spatial Topology and Network Data Models Developer's Guide*.

1.10 Spatial Aggregate Functions

SQL has long had aggregate functions, which are used to aggregate the results of a SQL query. The following example uses the SUM aggregate function to aggregate employee salaries by department:

```
SELECT SUM(salary), dept
```



```
FROM employees
GROUP BY dept;
```

Oracle Spatial aggregate functions aggregate the results of SQL queries involving geometry objects. Spatial aggregate functions return a geometry object of type `SDO_GEOMETRY`. For example, the following statement returns the minimum bounding rectangle of all geometries in a table (using the definitions and data from [Section 2.1](#)):

```
SELECT SDO_AGGR_MBR(shape) FROM cola_markets;
```

The following example returns the union of all geometries except `cola_d`:

```
SELECT SDO_AGGR_UNION(SDOAGGRTYPE(c.shape, 0.005))
FROM cola_markets c WHERE c.name <> 'cola_d';
```

For reference information about the spatial aggregate functions and examples of their use, see [Chapter 20](#).

Note: Spatial aggregate functions are supported for two-dimensional geometries only, except for `SDO_AGGR_MBR`, which is supported for both two-dimensional and three-dimensional geometries.

1.10.1 SDOAGGRTYPE Object Type

Many spatial aggregate functions accept an input parameter of type `SDOAGGRTYPE`. Oracle Spatial defines the object type `SDOAGGRTYPE` as:

```
CREATE TYPE sdoaggrtype AS OBJECT (
  geometry SDO_GEOMETRY,
  tolerance NUMBER);
```

Note: Do not use `SDOAGGRTYPE` as the data type for a column in a table. Use this type only in calls to spatial aggregate functions.

The tolerance value in the `SDOAGGRTYPE` definition should be the same as the `SDO_TOLERANCE` value specified in the `DIMINFO` column in the `xxx_SDO_GEOM_METADATA` views for the geometries, unless you have a specific reason for wanting a different value. For more information about tolerance, see [Section 1.5.5](#); for information about the `xxx_SDO_GEOM_METADATA` views, see [Section 2.8](#).

The tolerance value in the `SDOAGGRTYPE` definition can affect the result of a spatial aggregate function. [Figure 1–8](#) shows a spatial aggregate union (`SDO_AGGR_UNION`) operation of two geometries using two different tolerance values: one smaller and one larger than the distance between the geometries.

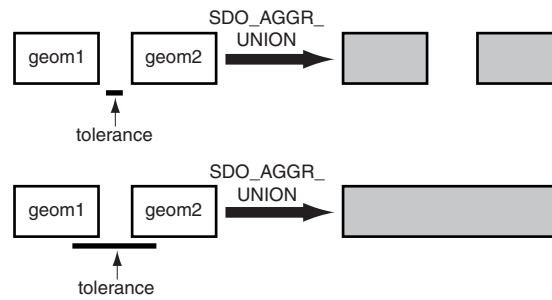
Figure 1–8 Tolerance in an Aggregate Union Operation

In the first aggregate union operation in [Figure 1–8](#), where the tolerance is less than the distance between the rectangles, the result is a compound geometry consisting of two rectangles. In the second aggregate union operation, where the tolerance is greater than the distance between the rectangles, the result is a single geometry.

1.11 Three-Dimensional Spatial Objects

Effective with Oracle Database Release 11.1, Oracle Spatial supports the storage and retrieval of three-dimensional spatial data, which can include points, point clouds (collections of points), lines, polygons, surfaces, and solids. [Table 1–1](#) show the SDO_GTYPE and element-related attributes of the SDO_GEOMETRY type that are relevant to three-dimensional geometries. (The SDO_GEOMETRY type is explained in [Section 2.2](#).)

Table 1–1 SDO_GEOMETRY Attributes for Three-Dimensional Geometries

Type of 3-D Data	SDO_GTYPE	Element Type, Interpretation in SDO_ELEM_INFO
Point	3001	Does not apply. Specify all 3 dimension values in the SDO_POINT_TYPE attribute.
Line	3002	2, 1
Polygon	3003	1003, 1: planar exterior polygon 2003, 1: planar interior polygon 1003, 3: planar exterior rectangle 2003, 3: planar interior rectangle
Surface	3003	1006, 1: surface (followed by element information for the polygons)
Collection	3004	Same considerations as for two-dimensional
Multipoint (point cloud)	3005	1, <i>n</i> (where <i>n</i> is the number of points)
Multiline	3006	Same considerations as for two-dimensional
Multisurface	3007	Element definitions for one or more surfaces
Solid	3008	Simple solid formed by a single closed surface: one element type 1007, followed by one element type 1006 (the external surface) and optionally one or more element type 2006 (internal surfaces) Composite solid formed by multiple adjacent simple solids: one element type 1008 (holding the count of simple solids), followed by any number of element type 1007 (each describing one simple solid)

Table 1–1 (Cont.) SDO_GEOMETRY Attributes for Three-Dimensional Geometries

Type of 3-D Data	SDO_GTYPE	Element Type, Interpretation in SDO_ELEM_INFO
Multisolid	3009	Element definitions for one or more simple solids (element type 1007) or composite solids (element type 1008)

The following Spatial operators consider all three dimensions in their computations:

- [SDO_ANYINTERACT](#)
- [SDO_FILTER](#)
- [SDO_INSIDE](#) (for solid geometries only)
- [SDO_NN](#)
- [SDO_WITHIN_DISTANCE](#)

The other operators consider only the first two dimensions. For some of preceding operators the height information is ignored when dealing with geodetic data, as explained later in this section. (Spatial operators are described in [Chapter 19](#).)

The [SDO_GEOM.SDO_VOLUME](#) function applies only to solid geometries, which are by definition three-dimensional; however, this function cannot be used with geodetic data. (This function is described in [Chapter 24](#).) For information about support for three-dimensional geometries with other SDO_GEOM subprograms, see the usage information after [Table 24–1](#), "Geometry Subprograms".

For distance computations with three-dimensional geometries:

- If the data is geodetic (geographic 3D), the distance computations are done on the geodetic surface.
- If the data is non-geodetic (projected or local), the distance computations are valid only if the unit of measure is the same for all three dimensions.

To have any functions, procedures, or operators consider all three dimensions, you must specify `PARAMETERS ('sdo_indx_dims=3')` in the [CREATE INDEX](#) statement when you create the spatial index on a spatial table containing Geographic3D data (longitude, latitude, ellipsoidal height). If you do not specify that parameter in the [CREATE INDEX](#) statement, a two-dimensional index is created.

For Spatial functions, procedures, and operators that consider all three dimensions, distance and length computations correctly factor in the height or elevation. For example, consider two three-dimensional points, one at the origin of a Cartesian space (0,0,0), and the other at X=3 on the Y axis and a height (Z) of 4 (3,0,4).

- If the operation considers all three dimensions, the distance between the two points is 5. (Think of the hypotenuse of a 3-4-5 right triangle.)
- If the operation considers only two dimensions, the distance between the two points is 3. (That is, the third dimension, or height, is ignored.)

However, for the following operators and subprograms, when dealing with geodetic data, the distances with three-dimensional geometries are computed between the "ground" representations (for example, the longitude/latitude extent of the footprint of a building), and the height information is ignored:

- [SDO_NN](#) operator
- [SDO_WITHIN_DISTANCE](#) operator
- [SDO_GEOM.SDO_DISTANCE](#) function
- [SDO_GEOM.WITHIN_DISTANCE](#) function

For a two-dimensional query window with three-dimensional data, you can use the [SDO_FILTER](#) operator, but not any other spatial operators.

For examples of creating different types of three-dimensional spatial geometries, see [Section 2.7.9](#). That section also includes an example showing how to update the spatial metadata and create spatial indexes for three-dimensional geometries.

For information about support for three-dimensional coordinate reference systems, see [Section 6.5](#).

Three-dimensional support does not apply to many spatial aggregate functions and PL/SQL packages and subprograms. The following are supported for two-dimensional geometries only:

- Spatial aggregate functions, except for [SDO_AGGR_MBR](#), which is supported for both two-dimensional and three-dimensional geometries.
- [SDO_GEOM](#) (geometry) subprograms, *except for the following, which are supported for both two-dimensional and three-dimensional geometries:*
 - [SDO_GEOM.RELATE](#) with the ANYINTERACT mask
 - [SDO_GEOM.SDO_AREA](#)
 - [SDO_GEOM.SDO_DISTANCE](#)
 - [SDO_GEOM.SDO_LENGTH](#)
 - [SDO_GEOM.SDO_MAX_MBR_ORDINATE](#)
 - [SDO_GEOM.SDO_MBR](#)
 - [SDO_GEOM.SDO_MIN_MBR_ORDINATE](#)
 - [SDO_GEOM.SDO_VOLUME](#)
 - [SDO_GEOM.VALIDATE_GEOMETRY_WITH_CONTEXT](#)
 - [SDO_GEOM.VALIDATE_LAYER_WITH_CONTEXT](#)
 - [SDO_GEOM.WITHIN_DISTANCE](#)
- [SDO_SAM](#) (spatial analysis and mining) subprograms
- [SDO_MIGRATE.TO_CURRENT](#) procedure

1.11.1 Modeling Surfaces

A surface contains an area but not a volume, and it can have two or three dimensions. A surface is often constructed by a set of planar regions.

Surfaces can be modeled as surface-type [SDO_GEOMETRY](#) objects or, if they are very large, as [SDO_TIN](#) objects. The surface-type in [SDO_GEOMETRY](#) can be an arbitrary surface defining a contiguous area bounded by adjacent three-dimensional polygons. The number of polygons in the [SDO_GEOMETRY](#) is limited by the number of ordinates that can be in the [SDO_ORDINATES_ARRAY](#). An [SDO_TIN](#) object, on the other hand, models the surface as a network of triangles with no explicit limit on the number of triangles.

Surfaces are stored as a network of triangles, called triangulated irregular networks, or **TINs**. The TIN model represents a surface as a set of contiguous, non-overlapping triangles. Within each triangle the surface is represented by a plane. The triangles are made from a set of points called mass points. If mass points are carefully selected, the TIN represents an accurate representation of the model of the surface. Well-placed mass points occur where there is a major change in the shape of the surface, for

example, at the peak of a mountain, the floor of a valley, or at the edge (top and bottom) of cliffs.

TINs are generally computed from a set of three-dimensional points specifying coordinate values in the longitude (x), latitude (y), and elevation (z) dimensions. Oracle TIN generation software uses the Delaunay triangulation algorithm, but it is not required that TIN data be formed using only Delaunay triangulation techniques.

The general process for working with a TIN is as follows:

1. Initialize the TIN, using the [SDO_TIN_PKG.INIT](#) function.
2. Create the TIN, using the [SDO_TIN_PKG.CREATE_TIN](#) procedure.
3. As needed for queries, clip the TIN, using the [SDO_TIN_PKG.CLIP_TIN](#) function.
4. If necessary, use the [SDO_TIN_PKG.TO_GEOMETRY](#) function (for example, to convert the result of a clip operation into a single SDO_GEOMETRY object).

The PL/SQL subprograms for working with TINs are described in [Chapter 30](#).

For a Java example of working with TINs, see the following files:

```
$ORACLE_HOME/md/demo/TIN/examples/java/README.txt
$ORACLE_HOME/md/demo/TIN/examples/java/readTIN.java
```

1.11.2 Modeling Solids

The simplest types of solids can be represented as cuboids, such as a cube or a brick. A more complex solid is a **frustum**, which is a pyramid formed by cutting a larger pyramid (with three or more faces) by a plane parallel to the base of that pyramid. Frustums can only be used as query windows to spatial operators. Frustums and cubes are typically modeled as solid-type SDO_GEOMETRY objects. [Figure 1–9](#) shows a frustum as a query window, with two spatial objects at different distances from the view point.

Figure 1–9 Frustum as Query Window for Spatial Objects

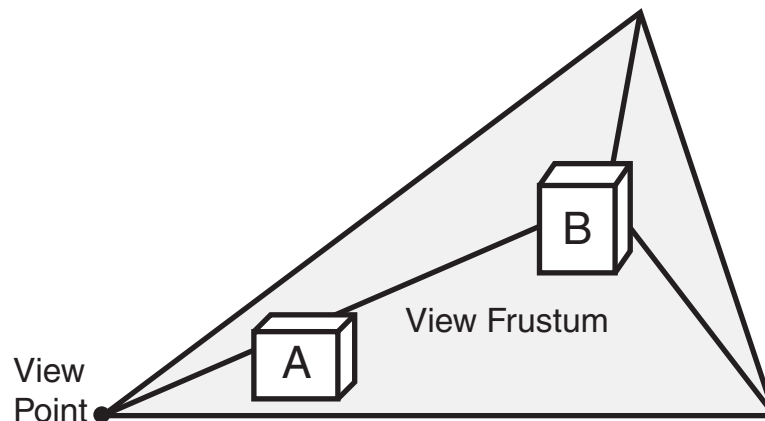

Point clouds, which are large collections of points, can sometimes be used to model the shape or structure of solid and surface geometries. Most applications that use point cloud data contain one or both of the following kinds of spatial queries: queries based on location, and queries based on both location and visibility (that is, visibility queries).

Most applications that use point cloud data seek to minimize data transfer by retrieving objects based on their distance from a view point. For example, in [Figure 1–9](#), object B is farther from the view point than object A, and therefore the application might retrieve object A in great detail (high resolution) and object B in less detail (low resolution). In most scenarios, the number of objects increases significantly as the distance from the view point increases; and if farther objects are retrieved at lower resolutions than nearer objects, the number of bytes returned by the query and the rendering time for the objects decrease significantly.

The general process for working with a point cloud is as follows:

1. Initialize the point cloud, using the [SDO_PC_PKG.INIT](#) function.
2. Create the point cloud, using the [SDO_PC_PKG.CREATE_PC](#) procedure.
3. As needed for queries, clip the point cloud, using the [SDO_PC_PKG.CLIP_PC](#) function.
4. If necessary, use the [SDO_PC_PKG.TO_GEOMETRY](#) function (for example, to convert the result of a clip operation into a single SDO_GEOMETRY object).

The PL/SQL subprograms for working with point clouds are described in [Chapter 28](#).

For a Java example of working with point clouds, see the following files:

```

$ORACLE_HOME/md/demo/PointCloud/examples/java/README.txt
$ORACLE_HOME/md/demo/PointCloud/examples/java/readPointCloud.java

```

1.11.3 Three-Dimensional Optimized Rectangles

Instead of specifying all the vertices for a three-dimensional rectangle (a polygon in the shape of rectangle in three-dimensional space), you can represent the rectangle by specifying just the two corners corresponding to the minimum ordinate values (*min-corner*) and the maximum ordinate values (*max-corner*) for the X, Y, and Z dimensions.

The orientation of a three-dimensional rectangle defined in this way is as follows:

- If the rectangle is specified as $\langle \textit{min-corner}, \textit{max-corner} \rangle$, the normal points in the positive direction of the perpendicular third dimension.
- If the rectangle is specified as $\langle \textit{max-corner}, \textit{min-corner} \rangle$, the normal points in the negative direction of the perpendicular third dimension.

For example, if the rectangle is in the XY plane and the order of the vertices is $\langle \textit{min-corner}, \textit{max-corner} \rangle$, the normal is along the positive Z-axis; but if the order is $\langle \textit{max-corner}, \textit{min-corner} \rangle$, the normal is along the negative Z-axis.

Using these orientation rules for rectangles, you can specify the order of the *min-corner* and *max-corner* vertices for a rectangle appropriately so that the following requirements are met:

- The normal for each polygon in a solid always points outward from the solid when the rectangle is part of the solid.
- An inner rectangle polygon is oriented in the reverse direction as its outer when the rectangle is part of a surface.

1.11.4 Using Texture Data

Note: This section describes concepts that you will need to understand for using texture data with Spatial. However, the texture metadata is not yet fully implemented in Oracle Spatial, and a viewer is not yet supported. This section will be updated when texture support is released.

A **texture** is an image that represents one or more parts of a feature. Textures are commonly used with visualizer applications (viewers) that display objects stored as spatial geometries. For example, a viewer might display an office building (three-dimensional solid) using textures, to allow a more realistic visualization than using just colors. Textures can be used with two-dimensional and three-dimensional geometries.

In the simplest case, a rectangular geometry can be draped with a texture bitmap. However, often only a sub-region of a texture bitmap is used, as in the following example cases:

- If the texture bitmap contains multiple sides of the same building, as well as the roof and roof gables. In this case, each bitmap portion is draped over one of the geometry faces.
- If the texture bitmap represents a single panel or window on the building surface, and a geometric face represents a wall with 15 such panels or windows (five on each of three floors). In this case, the single texture bitmap is tiled 15 times over the face.
- If the face is non-rectangular sub-faces, such as roof gables. In this case, only a portion (possibly triangular) of the texture bitmap is used.

[Figure 1–10](#) shows a large rectangular surface that, when viewed, appears to consist of three textures, each of which is repeated multiple times in various places on the surface.

Figure 1–10 Faces and Textures

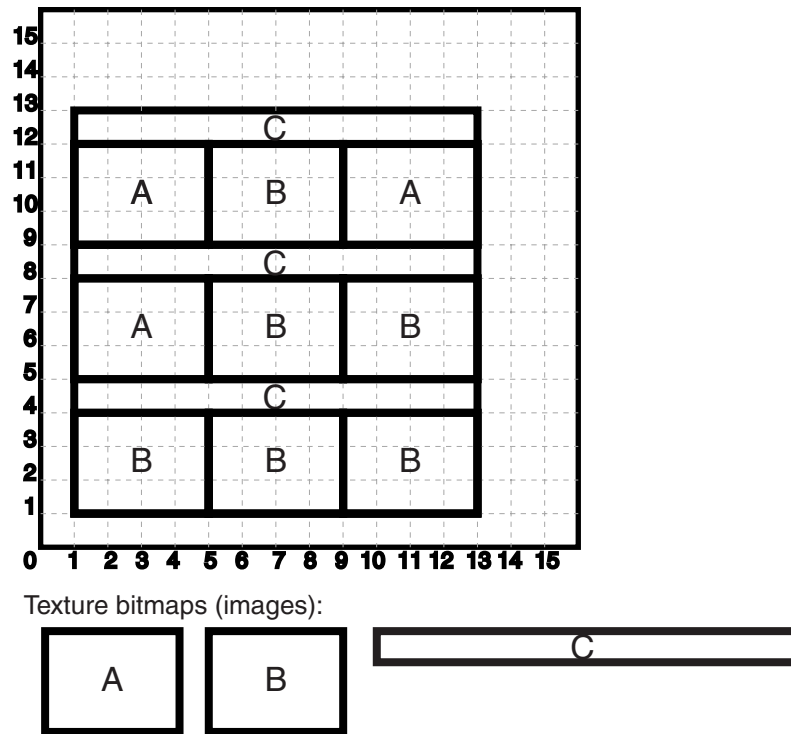

As shown in [Figure 1–10](#):

- The entire image is a large surface that consists of 12 smaller rectangular faces (surface geometries), each of which can be represented by one of three images (labeled A, B, and C).
- Three texture bitmaps (labeled A, B, and C) can be used to visualize all of the faces. In this case, bitmap A is used 3 times, bitmap B is used 6 times, and bitmap C is used 3 times.

[Figure 1–11](#) shows a texture bitmap mapped to a triangular face.

Figure 1–11 Texture Mapped to a Face

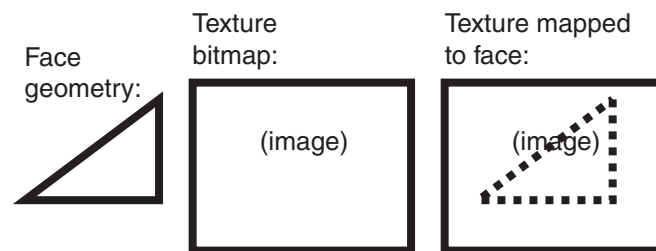

As shown in [Figure 1–11](#):

- The face (surface geometry) is a triangle. (For example, a side or roof of a building may contain several occurrences of this face.)
- The texture bitmap (image) is a rectangle, shown in the box in the middle.
- A portion of the texture bitmap represents an image of the face. This portion is shown by a dashed line in the box on the right.

In your application, you will need to specify coordinates within the texture bitmap to map the appropriate portion to the face geometry.

To minimize the storage requirements for image data representing surfaces, you should store images for only the distinct textures that will be needed. The data type for storing a texture is `SDO_ORDINATE_ARRAY`, which is used in the `SDO_GEOMETRY` type definition (explained in [Section 2.2](#)).

For example, assume that the large surface in [Figure 1–10](#) has the following definition:

```
SDO_GEOMETRY(
  2003, -- two-dimensional polygon
  NULL,
  NULL,
  SDO_ELEM_INFO_ARRAY(1,1003,1), -- one polygon (exterior polygon ring)
  SDO_ORDINATE_ARRAY(1,1, 1,13, 13,13, 1,13, 1,1)
)
```

Assume that you have a `MY_TEXTURE_COORDINATES` table with the following definition:

```
CREATE TABLE my_texture_coordinates (
  texture_coord_id NUMBER PRIMARY KEY,
  texture_name VARCHAR2(32),
  texture_coordinates SDO_ORDINATE_ARRAY);
```

[Example 1–1](#) inserts three texture coordinate definitions into this table. For each texture, its coordinates reflect one of the appropriate smaller rectangles shown in [Figure 1–10](#); however, you can choose any one of the appropriate rectangles for each texture. In [Example 1–1](#), the `SDO_ORDINATE_ARRAY` definitions for each texture reflect a polygon near the top of [Figure 1–10](#).

Example 1–1 Inserting Texture Coordinate Definitions

```
INSERT INTO my_texture_coordinates VALUES(
  1,
  'Texture_A',
  SDO_ORDINATE_ARRAY(1,9, 1,5, 5,12, 1,12, 1,9)
);

INSERT INTO my_texture_coordinates VALUES(
  2,
  'Texture_B',
  SDO_ORDINATE_ARRAY(5,9, 9,9, 9,12, 5,12, 5,9)
);

INSERT INTO my_texture_coordinates VALUES(
  3,
  'Texture_C',
  SDO_ORDINATE_ARRAY(1,12, 13,12, 13,13, 1,13, 1,12)
);
```

1.11.4.1 Schema Considerations with Texture Data

Texture bitmaps (stored as BLOBs or as URLs in `VARCHAR2` format) and texture coordinate arrays (stored using type `SDO_ORDINATE_ARRAY`) can be stored in the same table as the `SDO_GEOMETRY` column or in separate tables; however, especially for the texture bitmaps, it is usually better to use separate tables. Texture bitmaps are likely to be able to be shared among features (such as different office buildings), but texture coordinate definitions are less likely to be shareable among features. (For example, many office buildings may share the same general type of glass exterior, but

few of the buildings have the same number of windows and floors. In designing your textures and applications, you must consider how many buildings use the same texture sub-region or drape the texture in the same size of repetitive matrix.)

An exception is a texture coordinate array that drapes an entire texture bitmap over a rectangular geometric face. In this case, the texture coordinate array can be specified as (0,0, 1,0, 1,1, 0,1, 1,1), defined by vertices "lower left", "lower right", "upper right", "upper left", and closing with "lower left". Many data sets use this texture coordinate array extensively, because they have primarily rectangular faces and they store one facade for each texture bitmap.

If you used separate tables, you could link them to the surface geometries using foreign keys, as in [Example 1-2](#).

Example 1-2 Creating Tables for Texture Coordinates, Textures, and Surfaces

```
-- One row for each texture coordinates definition.
CREATE TABLE my_texture_coordinates (
  texture_coord_id NUMBER PRIMARY KEY,
  texture_coordinates SDO_ORDINATE_ARRAY);

-- One row for each texture.
CREATE TABLE my_textures(
  texture_id NUMBER PRIMARY KEY,
  texture BLOB);

-- One row for each surface (each individual "piece" of a
-- potentially larger surface).
CREATE TABLE my_surfaces(
  surface_id NUMBER PRIMARY KEY,
  surface_geometry SDO_GEOMETRY,
  texture_id NUMBER,
  texture_coord_id NUMBER,
  CONSTRAINT texture_id_fk
  FOREIGN KEY (texture_id) REFERENCES my_textures(texture_id),
  CONSTRAINT texture_coord_id_fk
  FOREIGN KEY (texture_coord_id) REFERENCES
  my_texture_coordinates(texture_coord_id));
```

1.11.5 Validation Checks for Three-Dimensional Geometries

The [SDO_GEOM.VALIDATE_GEOMETRY_WITH_CONTEXT](#) and [SDO_GEOM.VALIDATE_LAYER_WITH_CONTEXT](#) subprograms can validate two-dimensional and three-dimensional geometries. For a three-dimensional geometry, these subprograms perform any necessary checks on any two-dimensional geometries (see the Usage Notes for [SDO_GEOM.VALIDATE_GEOMETRY_WITH_CONTEXT](#)) within the overall three-dimensional geometry, but also several checks specific to the three-dimensional nature of the overall object.

For a simple solid (one outer surface and any number of inner surfaces), these subprograms perform the following checks:

- Closedness: The solid must be closed.
- Reachability: Each face of a solid must have a full-edge intersection with its neighboring faces, and all faces must be reachable from any face.
- Inner-outer disjointedness: An inner surface must not intersect the outer surface at more than a point or a line; that is, there must be no overlapping areas with inner surfaces.

- No surface patch: No additional surfaces can be defined on the surfaces that make up the solid.
- Orientation: For all surfaces, the vertices must be aligned so that the normal vector (or surface normal, or "the normal") points to the outside of (away from) the outer solid. Thus, the volume of the outer solid must be greater than zero, and the volume of any inner solid must be less than zero.

For a composite solid (one or more solids connected to each other), these subprograms perform the following checks:

- Connectedness: All solids of a composite solid must share at least one face.
- Zero-volume intersections: Any intersections of the solids in a composite solid must have a volume of zero.

For a multisolid (one or more solids, each of which is a simple or composite solid), these subprograms perform the following check:

- Disjointedness: Any two solids of a multisolid can share points or lines, but must not intersect in any other manner.

1.12 Geocoding

Geocoding is the process of converting tables of address data into standardized address, location, and possibly other data. The result of a geocoding operation includes the pair of longitude and latitude coordinates that correspond with the input address or location. For example, if the input address is *22 Monument Square, Concord, MA 01742*, the longitude and latitude coordinates in the result of the geocoding operation may be (depending on the geocoding data provider) -71.34937 and 42.46101, respectively.

Given a geocoded address, you can perform proximity or location queries using a spatial engine, such as Oracle Spatial, or demographic analysis using tools and data from Oracle's business partners. In addition, you can use geocoded data with other spatial data such as block group, postal code, and county code for association with demographic information. Results of analyses or queries can be presented as maps, in addition to tabular formats, using third-party software integrated with Oracle Spatial.

For conceptual and usage information about the geocoding capabilities of Oracle Spatial, see [Chapter 11](#). For reference information about the MDSYS.SDO_GCDR PL/SQL package, see [Chapter 23](#).

1.13 Spatial Java Application Programming Interface

Oracle Spatial provides a Java application programming interface (API) that includes the following packages:

- `oracle.spatial.geometry` provides support for the Spatial SQL SDO_GEOOMETRY data type, which is documented in this guide.
- `oracle.spatial.georaster` provides support for the core GeoRaster features, which are documented in *Oracle Spatial GeoRaster Developer's Guide*.
- `oracle.spatial.georaster.image` provides support for generating Java images from a GeoRaster object or subset of a GeoRaster object, and for processing the images. These features are documented in *Oracle Spatial GeoRaster Developer's Guide*.

- `oracle.spatial.georaster.sql` provides support for wrapping the GeoRaster PL/SQL API, which is documented in *Oracle Spatial GeoRaster Developer's Guide*.
- `oracle.spatial.network` provides support for the Oracle Spatial network data model, which is documented in *Oracle Spatial Topology and Network Data Models Developer's Guide*.
- `oracle.spatial.network.lod` provides support for the load-on-demand (LOD) approach of network analysis in the Oracle Spatial network data model, which is documented in *Oracle Spatial Topology and Network Data Models Developer's Guide*.
- `oracle.spatial.network.lod.config` provides support for the configuration of load-on-demand (LOD) network analysis in the Oracle Spatial network data model, which is documented in *Oracle Spatial Topology and Network Data Models Developer's Guide*.
- `oracle.spatial.topo` provides support for the Oracle Spatial topology data model, which is documented in *Oracle Spatial Topology and Network Data Models Developer's Guide*.
- `oracle.spatial.util` provides classes that perform miscellaneous operations.

For detailed reference information about the classes and interfaces in these packages, see *Oracle Spatial Java API Reference* (Javadoc).

The Spatial Java class libraries are in `.jar` files under the `<ORACLE_HOME>/md/jlib/` directory.

1.14 Predefined User Accounts Created by Spatial

During installation, Spatial creates user accounts that have the minimum privileges needed to perform their jobs. These accounts are created locked and expired; so if you need to use the accounts, you must unlock them. [Table 1–2](#) lists the predefined user accounts created by Spatial.

Table 1–2 Predefined User Accounts Created by Spatial

User Account	Description
MDDATA	The schema used by Oracle Spatial for storing data used by geocoding and routing applications. This is the default schema for Oracle software that accesses geocoding and routing data.
SPATIAL_CSW_ADMIN_USR	The Catalog Services for the Web (CSW) account. It is used by the Oracle Spatial CSW cache manager to load all record type metadata and all record instances from the database into main memory for the record types that are cached.
SPATIAL_WFS_ADMIN_USR	The Web Feature Service (WFS) account. It is used by the Oracle Spatial WFS cache manager to load all feature type metadata and all feature instances from the database into main memory for the feature types that are cached.

For information about Oracle Database predefined user accounts, including how to secure these accounts, see *Oracle Database 2 Day + Security Guide*.

1.15 Performance and Tuning Information

Many factors can affect the performance of Oracle Spatial applications, such as the use of optimizer hints to influence the plan for query execution. This guide contains some information about performance and tuning where it is relevant to a particular topic. For example, [Section 1.7.2](#) discusses R-tree quality and its possible effect on query performance, and [Section 1.9](#) explains why spatial operators provide better performance than procedures and functions.

In addition, more Spatial performance and tuning information is available in one or more white papers through the Oracle Technology Network (OTN). That information is often more detailed than what is in this guide, and it is periodically updated as a result of internal testing and consultations with Spatial users. To find that information on the OTN, go to

<http://www.oracle.com/technology/products/spatial/>

Look for material relevant to Spatial performance and tuning.

1.16 OGC and ISO Compliance

Oracle Spatial is conformant with Open Geospatial Consortium (OGC) Simple Features Specification 1.1.1 (Document 99-049), starting with Oracle Database release 10g (version 10.1.0.4). Conformance with the Geometry Types Implementation means that Oracle Spatial supports all the types, functions, and language constructs detailed in Section 3.2 of the specification.

Synonyms are created to match all OGC function names except for `X(p Point)` and `Y(p Point)`. For these functions, you must use the names `OGC_X` and `OGC_Y` instead of just `X` and `Y`.

Oracle Spatial is conformant with the following International Organization for Standardization (ISO) standards:

- ISO 13249-3 SQL Multimedia and Application Packages - Part 3: Spatial
- ISO 19101: Geographic information - Reference model (definition of terms and approach)
- ISO 19109: Geographic information - Rules for application schema (called the General Feature Model)
- ISO 19111: Geographic information - Spatial referencing by coordinates (also OGC Abstract specification for coordinate reference systems)
- ISO 19118: Geographic information - Encoding (GML 2.1 and GML 3.1.1)
- ISO 19107: Geographic information - Spatial schema (also OGC Abstract specification for Geometry)

However, standards compliance testing for Oracle Spatial is ongoing, and compliance with more recent versions of standards or with new standards might be announced at any time. For current information about compliance with standards, see <http://www.oracle.com/technetwork/database/options/spatial/documentation/info/spatial-stds-support-094078.html>.

1.17 Spatial Release (Version) Number

To check which release of Spatial you are running, use the `SDO_VERSION` function. For example:

```
SELECT SDO_VERSION FROM DUAL;
```

```
SDO_VERSION
```

```
-----  
11.2.0.2.0
```

1.18 Moving Spatial Metadata (MDSYS.MOVE_SDO)

Database administrators (DBAs) can use the MDSYS.MOVE_SDO procedure to move all Oracle Spatial metadata tables to a specified target tablespace. By default, the Spatial metadata tables are created in the SYS_AUX tablespace in Release 11.1 and later releases, and in the SYSTEM tablespace in releases before 11.1.

The MDSYS.MOVE_SDO procedure has the following syntax:

```
MDSYS.MOVE_SDO(  
    target_tablespace_name IN VARCHAR2);
```

The required `target_tablespace_name` parameter specifies the name of the tablespace to which to move the Spatial metadata tables.

This procedure should be used only by DBAs.

During the move operation, all other Oracle Spatial capabilities are disabled.

The following example moves the Spatial metadata tables to the SYS_AUX tablespace.

```
EXECUTE MDSYS.MOVE_SDO('SYS_AUX');
```

1.19 Spatial Application Hardware Requirement Considerations

This section discusses some general guidelines that affect the amount of disk storage space and CPU power needed for applications that use Oracle Spatial. These guidelines are intended to supplement, not replace, any other guidelines you use for general application sizing.

The following characteristics of spatial applications can affect the need for storage space and CPU power:

- **Data volumes:** The amount of storage space needed for spatial objects depends on their complexity (precision of representation and number of points for each object). For example, storing one million point objects takes less space than storing one million road segments or land parcels. Complex natural features such as coastlines, seismic fault lines, rivers, and land types can require significant storage space if they are stored at a high precision.
- **Query complexity:** The CPU requirements for simple mapping queries, such as *Select all features in this rectangle*, are lower than for more complex queries, such as *Find all seismic fault lines that cross this coastline*.

1.20 Spatial Error Messages

Spatial error messages are documented in *Oracle Database Error Messages*.

Oracle error message documentation is only available in HTML. If you only have access to the Oracle Documentation DVD, you can browse the error messages by range. Once you find the specific range, use your browser's "find in page" feature to locate the specific message. When connected to the Internet, you can search for a specific error message using the error message search feature of the Oracle online documentation.

1.21 Spatial Examples

Oracle Spatial provides examples that you can use to reinforce your learning and to create models for coding certain operations. If you installed the demo files from the Oracle Database Examples media (see *Oracle Database Examples Installation Guide*), several examples are provided in the following directory:

```
$ORACLE_HOME/md/demo/examples
```

The following files in that directory are helpful for applications that use the Oracle Call Interface (OCI):

- `readgeom.c` and `readgeom.h`
- `writegeom.c` and `writegeom.h`

This guide also includes many examples in SQL and PL/SQL. One or more examples are usually provided with the reference information for each function or procedure, and several simplified examples are provided that illustrate table and index creation, combinations of functions and procedures, and advanced features:

- Inserting, indexing, and querying spatial data ([Section 2.1](#))
- Coordinate systems (spatial reference systems) ([Section 6.13](#))
- Linear referencing system (LRS) ([Section 7.7](#))
- SDO_GEOMETRY objects in function-based indexes ([Section 9.2](#))
- Complex queries ([Appendix C](#))

1.22 README File for Spatial and Related Features

A `README.txt` file supplements the information in the following manuals: *Oracle Spatial Developer's Guide* (this manual), *Oracle Spatial GeoRaster Developer's Guide*, and *Oracle Spatial Topology and Network Data Models Developer's Guide*. This file is located at:

```
$ORACLE_HOME/md/doc/README.txt
```

Spatial Data Types and Metadata

Oracle Spatial consists of a set of object data types, type methods, and operators, functions, and procedures that use these types. A geometry is stored as an object, in a single row, in a column of type `SDO_GEOMETRY`. Spatial index creation and maintenance is done using basic DDL (`CREATE`, `ALTER`, `DROP`) and DML (`INSERT`, `UPDATE`, `DELETE`) statements.

This chapter starts with a simple example that inserts, indexes, and queries spatial data. You may find it helpful to read this example quickly before you examine the detailed data type and metadata information later in the chapter.

This chapter contains the following major sections:

- [Section 2.1, "Simple Example: Inserting, Indexing, and Querying Spatial Data"](#)
- [Section 2.2, "SDO_GEOMETRY Object Type"](#)
- [Section 2.3, "SDO_GEOMETRY Methods"](#)
- [Section 2.4, "SDO_GEOMETRY Constructors"](#)
- [Section 2.5, "TIN-Related Object Types"](#)
- [Section 2.6, "Point Cloud-Related Object Types"](#)
- [Section 2.7, "Geometry Examples"](#)
- [Section 2.8, "Geometry Metadata Views"](#)
- [Section 2.9, "Spatial Index-Related Structures"](#)
- [Section 2.10, "Unit of Measurement Support"](#)

2.1 Simple Example: Inserting, Indexing, and Querying Spatial Data

This section presents a simple example of creating a spatial table, inserting data, creating the spatial index, and performing spatial queries. It refers to concepts that were explained in [Chapter 1](#) and that will be explained in other sections of this chapter.

The scenario is a soft drink manufacturer that has identified geographical areas of marketing interest for several products (colas). The colas could be those produced by the company or by its competitors, or some combination. Each area of interest could represent any user-defined criterion: for example, an area where that cola has the majority market share, or where the cola is under competitive pressure, or where the cola is believed to have significant growth potential. Each area could be a neighborhood in a city, or a part of a state, province, or country.

[Figure 2–1](#) shows the areas of interest for four colas.

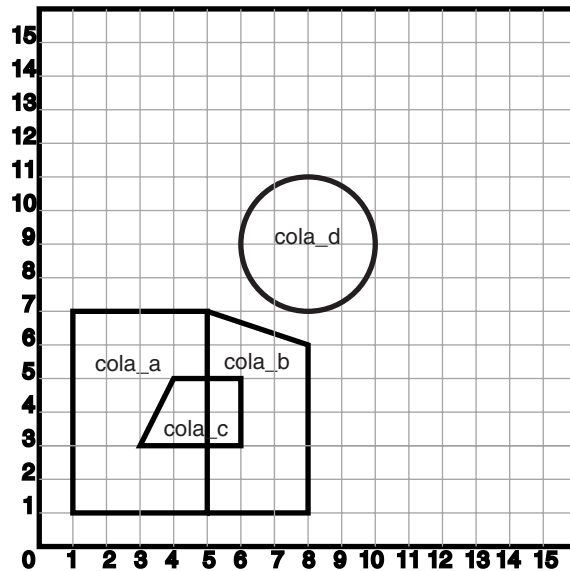
Figure 2–1 Areas of Interest for the Simple Example

[Example 2–1](#) performs the following operations:

- Creates a table (COLA_MARKETS) to hold the spatial data
- Inserts rows for four areas of interest (cola_a, cola_b, cola_c, cola_d)
- Updates the USER_SDO_GEOM_METADATA view to reflect the dimensional information for the areas
- Creates a spatial index (COLA_SPATIAL_IDX)
- Performs some spatial queries

Many concepts and techniques in [Example 2–1](#) are explained in detail in other sections of this chapter.

Example 2–1 Simple Example: Inserting, Indexing, and Querying Spatial Data

```
-- Create a table for cola (soft drink) markets in a
-- given geography (such as city or state).
-- Each row will be an area of interest for a specific
-- cola (for example, where the cola is most preferred
-- by residents, where the manufacturer believes the
-- cola has growth potential, and so on).
-- (For restrictions on spatial table and column names, see
-- Section 2.8.1 and Section 2.8.2.)
```

```
CREATE TABLE cola_markets (
  mkt_id NUMBER PRIMARY KEY,
  name VARCHAR2(32),
  shape SDO_GEOMETRY);
```

```
-- The next INSERT statement creates an area of interest for
-- Cola A. This area happens to be a rectangle.
-- The area could represent any user-defined criterion: for
-- example, where Cola A is the preferred drink, where
-- Cola A is under competitive pressure, where Cola A
-- has strong growth potential, and so on.
```



```

INSERT INTO cola_markets VALUES(
  1,
  'cola_a',
  SDO_GEOMETRY(
    2003, -- two-dimensional polygon
    NULL,
    NULL,
    SDO_ELEM_INFO_ARRAY(1,1003,3), -- one rectangle (1003 = exterior)
    SDO_ORDINATE_ARRAY(1,1, 5,7) -- only 2 points needed to
      -- define rectangle (lower left and upper right) with
      -- Cartesian-coordinate data
  )
);

-- The next two INSERT statements create areas of interest for
-- Cola B and Cola C. These areas are simple polygons (but not
-- rectangles).

INSERT INTO cola_markets VALUES(
  2,
  'cola_b',
  SDO_GEOMETRY(
    2003, -- two-dimensional polygon
    NULL,
    NULL,
    SDO_ELEM_INFO_ARRAY(1,1003,1), -- one polygon (exterior polygon ring)
    SDO_ORDINATE_ARRAY(5,1, 8,1, 8,6, 5,7, 5,1)
  )
);

INSERT INTO cola_markets VALUES(
  3,
  'cola_c',
  SDO_GEOMETRY(
    2003, -- two-dimensional polygon
    NULL,
    NULL,
    SDO_ELEM_INFO_ARRAY(1,1003,1), -- one polygon (exterior polygon ring)
    SDO_ORDINATE_ARRAY(3,3, 6,3, 6,5, 4,5, 3,3)
  )
);

-- Now insert an area of interest for Cola D. This is a
-- circle with a radius of 2. It is completely outside the
-- first three areas of interest.

INSERT INTO cola_markets VALUES(
  4,
  'cola_d',
  SDO_GEOMETRY(
    2003, -- two-dimensional polygon
    NULL,
    NULL,
    SDO_ELEM_INFO_ARRAY(1,1003,4), -- one circle
    SDO_ORDINATE_ARRAY(8,7, 10,9, 8,11)
  )
);

-----
-- UPDATE METADATA VIEW --

```

```

-----
-- Update the USER_SDO_GEOM_METADATA view. This is required
-- before the Spatial index can be created. Do this only once for each
-- layer (that is, table-column combination; here: COLA_MARKETS and SHAPE).

INSERT INTO user_sdo_geom_metadata
  (TABLE_NAME,
   COLUMN_NAME,
   DIMINFO,
   SRID)
VALUES (
  'cola_markets',
  'shape',
  SDO_DIM_ARRAY( -- 20X20 grid
    SDO_DIM_ELEMENT('X', 0, 20, 0.005),
    SDO_DIM_ELEMENT('Y', 0, 20, 0.005)
  ),
  NULL -- SRID
);

-----
-- CREATE THE SPATIAL INDEX --
-----

CREATE INDEX cola_spatial_idx
  ON cola_markets(shape)
  INDEXTYPE IS MDSYS.SPATIAL_INDEX;
-- Preceding statement created an R-tree index.

-----
-- PERFORM SOME SPATIAL QUERIES --
-----

-- Return the topological intersection of two geometries.
SELECT SDO_GEOM.SDO_INTERSECTION(c_a.shape, c_c.shape, 0.005)
  FROM cola_markets c_a, cola_markets c_c
  WHERE c_a.name = 'cola_a' AND c_c.name = 'cola_c';

-- Do two geometries have any spatial relationship?
SELECT SDO_GEOM.RELATE(c_b.shape, 'anyinteract', c_d.shape, 0.005)
  FROM cola_markets c_b, cola_markets c_d
  WHERE c_b.name = 'cola_b' AND c_d.name = 'cola_d';

-- Return the areas of all cola markets.
SELECT name, SDO_GEOM.SDO_AREA(shape, 0.005) FROM cola_markets;

-- Return the area of just cola_a.
SELECT c.name, SDO_GEOM.SDO_AREA(c.shape, 0.005) FROM cola_markets c
  WHERE c.name = 'cola_a';

-- Return the distance between two geometries.
SELECT SDO_GEOM.SDO_DISTANCE(c_b.shape, c_d.shape, 0.005)
  FROM cola_markets c_b, cola_markets c_d
  WHERE c_b.name = 'cola_b' AND c_d.name = 'cola_d';

-- Is a geometry valid?
SELECT c.name, SDO_GEOM.VALIDATE_GEOMETRY_WITH_CONTEXT(c.shape, 0.005)
  FROM cola_markets c WHERE c.name = 'cola_c';

-- Is a layer valid? (First, create the results table.)
CREATE TABLE val_results (sdo_rowid ROWID, result VARCHAR2(2000));
CALL SDO_GEOM.VALIDATE_LAYER_WITH_CONTEXT('COLA_MARKETS', 'SHAPE',

```

```
'VAL_RESULTS', 2);
SELECT * from val_results;
```

2.2 SDO_GEOMETRY Object Type

With Spatial, the geometric description of a spatial object is stored in a single row, in a single column of object type SDO_GEOMETRY in a user-defined table. Any table that has a column of type SDO_GEOMETRY must have another column, or set of columns, that defines a unique primary key for that table. Tables of this sort are sometimes referred to as spatial tables or spatial geometry tables.

Oracle Spatial defines the object type SDO_GEOMETRY as:

```
CREATE TYPE sdo_geometry AS OBJECT (
  SDO_GTYPE NUMBER,
  SDO_SRID NUMBER,
  SDO_POINT SDO_POINT_TYPE,
  SDO_ELEM_INFO SDO_ELEM_INFO_ARRAY,
  SDO_ORDINATES SDO_ORDINATE_ARRAY);
```

Oracle Spatial also defines the SDO_POINT_TYPE, SDO_ELEM_INFO_ARRAY, and SDO_ORDINATE_ARRAY types, which are used in the SDO_GEOMETRY type definition, as follows:

```
CREATE TYPE sdo_point_type AS OBJECT (
  X NUMBER,
  Y NUMBER,
  Z NUMBER);
CREATE TYPE sdo_elem_info_array AS VARRAY (1048576) of NUMBER;
CREATE TYPE sdo_ordinate_array AS VARRAY (1048576) of NUMBER;
```

Because the maximum SDO_ORDINATE_ARRAY size is 1,048,576 numbers, the maximum number of vertices in an SDO_GEOMETRY object depends on the number of dimensions per vertex: 524,288 for two dimensions, 349,525 for three dimensions, and 262,144 for four dimensions.

The sections that follow describe the semantics of each SDO_GEOMETRY attribute, and then describe some usage considerations ([Section 2.2.6](#)).

The SDO_GEOMETRY object type has methods that provide convenient access to some of the attributes. These methods are described in [Section 2.3](#).

Some Spatial data types are described in locations other than this section:

- [Section 11.2](#) describes data types for geocoding.
- *Oracle Spatial GeoRaster Developer's Guide* describes data types for Oracle Spatial GeoRaster.
- *Oracle Spatial Topology and Network Data Models Developer's Guide* describes data types for the Oracle Spatial topology data model.

2.2.1 SDO_GTYPE

The SDO_GTYPE attribute indicates the type of the geometry. Valid geometry types correspond to those specified in the *Geometry Object Model for the OGIS Simple Features for SQL* specification (with the exception of Surfaces). The numeric values differ from those given in the OGIS specification, but there is a direct correspondence between the names and semantics where applicable.

The SDO_GTYPE value is 4 digits in the format *DLTT*, where:

- *D* identifies the number of dimensions (2, 3, or 4)
- *L* identifies the linear referencing measure dimension for a three-dimensional linear referencing system (LRS) geometry, that is, which dimension (3 or 4) contains the measure value. For a non-LRS geometry, or to accept the Spatial default of the last dimension as the measure for an LRS geometry, specify 0. For information about the linear referencing system (LRS), see [Chapter 7](#).
- *TT* identifies the geometry type (00 through 09, with 10 through 99 reserved for future use).

[Table 2–1](#) shows the valid SDO_GTYPE values. The Geometry Type and Description values reflect the OGIS specification.

Table 2–1 Valid SDO_GTYPE Values

Value	Geometry Type	Description
DL00	UNKNOWN_GEOMETRY	Spatial ignores this geometry.
DL01	POINT	Geometry contains one point.
DL02	LINE or CURVE	Geometry contains one line string that can contain straight or circular arc segments, or both. (LINE and CURVE are synonymous in this context.)
DL03	POLYGON or SURFACE	Geometry contains one polygon with or without holes, ¹ or one surface consisting of one or more polygons. In a three-dimensional polygon, all points must be on the same plane.
DL04	COLLECTION	Geometry is a heterogeneous collection of elements. COLLECTION is a superset that includes all other types.
DL05	MULTIPOINT	Geometry has one or more points. (MULTIPOINT is a superset of POINT.)
DL06	MULTILINE or MULTICURVE	Geometry has one or more line strings. (MULTILINE and MULTICURVE are synonymous in this context, and each is a superset of both LINE and CURVE.)
DL07	MULTIPOLYGON or MULTISURFACE	Geometry can have multiple, disjoint polygons (more than one exterior boundary), or surfaces (MULTIPOLYGON is a superset of POLYGON, and MULTISURFACE is a superset of SURFACE.)
DL08	SOLID	Geometry consists of multiple surfaces and is completely enclosed in a three-dimensional space. Can be a cuboid or a frustum.
DL09	MULTISOLID	Geometry can have multiple, disjoint solids (more than one exterior boundary). (MULTISOLID is a superset of SOLID.)

¹ For a polygon with holes, enter the exterior boundary first, followed by any interior boundaries.

The *D* in the Value column of [Table 2–1](#) is the number of dimensions: 2, 3, or 4. For example, an SDO_GTYPE value of 2003 indicates a two-dimensional polygon. The number of dimensions reflects the number of ordinates used to represent each vertex (for example, X,Y for two-dimensional objects).

In any given layer (column), all geometries must have the same number of dimensions. For example, you cannot mix two-dimensional and three-dimensional data in the same layer.

The following methods are available for returning the individual *DLTT* components of the SDO_GTYPE for a geometry object: `Get_Dims`, `Get_LRS_Dim`, and `Get_Gtype`. These methods are described in [Section 2.3](#).

For more information about SDO_GTYPE values for three-dimensional geometries, see [Table 1–1](#) in [Section 1.11](#).

2.2.2 SDO_SRID

The SDO_SRID attribute can be used to identify a coordinate system (spatial reference system) to be associated with the geometry. If SDO_SRID is null, no coordinate system is associated with the geometry. If SDO_SRID is not null, it must contain a value from the SRID column of the SDO_COORD_REF_SYS table (described in [Section 6.7.9](#)), and this value must be inserted into the SRID column of the USER_SDO_GEOM_METADATA view (described in [Section 2.8](#)).

All geometries in a geometry column must have the same SDO_SRID value if a spatial index will be built on that column.

For information about coordinate systems, see [Chapter 6](#).

2.2.3 SDO_POINT

The SDO_POINT attribute is defined using the SDO_POINT_TYPE object type, which has the attributes X, Y, and Z, all of type NUMBER. (The SDO_POINT_TYPE definition is shown in [Section 2.2](#).) If the SDO_ELEM_INFO and SDO_ORDINATES arrays are both null, and the SDO_POINT attribute is non-null, then the X, Y, and Z values are considered to be the coordinates for a point geometry. Otherwise, the SDO_POINT attribute is ignored by Spatial. You should store point geometries in the SDO_POINT attribute for optimal storage; and if you have only point geometries in a layer, it is strongly recommended that you store the point geometries in the SDO_POINT attribute.

[Section 2.7.5](#) illustrates a point geometry and provides examples of inserting and querying point geometries.

Note: Do not use the SDO_POINT attribute in defining a linear referencing system (LRS) point or an oriented point. For information about LRS, see [Chapter 7](#). For information about oriented points, see [Section 2.7.6](#).

2.2.4 SDO_ELEM_INFO

The SDO_ELEM_INFO attribute is defined using a varying length array of numbers. This attribute lets you know how to interpret the ordinates stored in the SDO_ORDINATES attribute (described in [Section 2.2.5](#)).

Each triplet set of numbers is interpreted as follows:

- SDO_STARTING_OFFSET -- Indicates the offset within the SDO_ORDINATES array where the first ordinate for this element is stored. Offset values start at 1 and not at 0. Thus, the first ordinate for the first element will be at SDO_GEOMETRY.SDO_ORDINATES(1). If there is a second element, its first ordinate will be at SDO_GEOMETRY.SDO_ORDINATES(*n*), where *n* reflects the position within the SDO_ORDINATE_ARRAY definition (for example, 19 for the 19th number, as in [Figure 2–4](#) in [Section 2.7.2](#)).

- SDO_ETYPE -- Indicates the type of the element. Valid values are shown in [Table 2-2](#).

SDO_ETYPE values 1, 2, 1003, and 2003 are considered *simple elements*. They are defined by a single triplet entry in the SDO_ELEM_INFO array. For SDO_ETYPE values 1003 and 2003, the first digit indicates *exterior* (1) or *interior* (2):

1003: exterior polygon ring (must be specified in counterclockwise order)

2003: interior polygon ring (must be specified in clockwise order)

Note: The use of 3 as an SDO_ETYPE value for polygon ring elements in a single geometry is discouraged. You should specify 3 only if you do not know if the simple polygon is exterior or interior, and you should then upgrade the table or layer to the current format using the [SDO_MIGRATE.TO_CURRENT](#) procedure, described in [Chapter 26](#).

You cannot mix 1-digit and 4-digit SDO_ETYPE values in a single geometry.

SDO_ETYPE values 4, 1005, 2005, 1006, and 2006 are considered *compound elements*. They contain at least one header triplet with a series of triplet values that belong to the compound element. For 4-digit SDO_ETYPE values, the first digit indicates *exterior* (1) or *interior* (2):

1005: exterior polygon ring (must be specified in counterclockwise order)

2005: interior polygon ring (must be specified in clockwise order)

1006: exterior surface consisting of one or more polygon rings

2006: interior surface in a solid element

1007: solid element

The elements of a compound element are contiguous. The last point of a subelement in a compound element is the first point of the next subelement. The point is not repeated.

- SDO_INTERPRETATION -- Means one of two things, depending on whether or not SDO_ETYPE is a compound element.

If SDO_ETYPE is a compound element (4, 1005, or 2005), this field specifies how many subsequent triplet values are part of the element.

If the SDO_ETYPE is not a compound element (1, 2, 1003, or 2003), the interpretation attribute determines how the sequence of ordinates for this element is interpreted. For example, a line string or polygon boundary may be made up of a sequence of connected straight line segments or circular arcs.

Descriptions of valid SDO_ETYPE and SDO_INTERPRETATION value pairs are given in [Table 2-2](#).

If a geometry consists of more than one element, then the last ordinate for an element is always one less than the starting offset for the next element. The last element in the geometry is described by the ordinates from its starting offset to the end of the SDO_ORDINATES varying length array.

For compound elements (SDO_ETYPE values 4, 1005, or 2005), a set of *n* triplets (one for each subelement) is used to describe the element. It is important to remember that subelements of a compound element are contiguous. The last point of a subelement is

the first point of the next subelement. For subelements 1 through $n-1$, the end point of one subelement is the same as the starting point of the next subelement. The starting point for subelements 2... $n-2$ is the same as the end point of subelement 1... $n-1$. The last ordinate of subelement n is either the starting offset minus 1 of the next element in the geometry, or the last ordinate in the SDO_ORDINATES varying length array.

The current size of a varying length array can be determined by using the function `varray_variable.Count` in PL/SQL or `OCICollSize` in the Oracle Call Interface (OCI).

The semantics of each SDO_ETYPE element and the relationship between the SDO_ELEM_INFO and SDO_ORDINATES varying length arrays for each of these SDO_ETYPE elements are given in [Table 2-2](#).

Table 2-2 Values and Semantics in SDO_ELEM_INFO

SDO_ETYPE	SDO_INTERPRETATION	Meaning
0	(any numeric value)	Type 0 (zero) element. Used to model geometry types not supported by Oracle Spatial. For more information, see Section 2.7.7 .
1	1	Point type.
1	0	Orientation for an oriented point. For more information, see Section 2.7.6 .
1	$n > 1$	Point cluster with n points.
2	1	Line string whose vertices are connected by straight line segments.
2	2	Line string made up of a connected sequence of circular arcs. Each circular arc is described using three coordinates: the start point of the arc, any point on the arc, and the end point of the arc. The coordinates for a point designating the end of one arc and the start of the next arc are not repeated. For example, five coordinates are used to describe a line string made up of two connected circular arcs. Points 1, 2, and 3 define the first arc, and points 3, 4, and 5 define the second arc, where point 3 is only stored once.
1003 or 2003	1	Simple polygon whose vertices are connected by straight line segments. You must specify a point for each vertex; and the last point specified must be exactly the same point as the first (within the tolerance value), to close the polygon. For example, for a 4-sided polygon, specify 5 points, with point 5 the same as point 1.
1003 or 2003	2	Polygon made up of a connected sequence of circular arcs that closes on itself. The end point of the last arc is the same as the start point of the first arc. Each circular arc is described using three coordinates: the start point of the arc, any point on the arc, and the end point of the arc. The coordinates for a point designating the end of one arc and the start of the next arc are not repeated. For example, five coordinates are used to describe a polygon made up of two connected circular arcs. Points 1, 2, and 3 define the first arc, and points 3, 4, and 5 define the second arc. The coordinates for points 1 and 5 must be the same (tolerance is not considered), and point 3 is not repeated.

Table 2–2 (Cont.) Values and Semantics in SDO_ELEM_INFO

SDO_ETYPE	SDO_INTERPRETATION	Meaning
1003 or 2003	3	<p>Rectangle type (sometimes called <i>optimized rectangle</i>). A bounding rectangle such that only two points, the lower-left and the upper-right, are required to describe it. The rectangle type can be used with geodetic or non-geodetic data. However, with geodetic data, use this type only to create a query window (not for storing objects in the database).</p> <p>For information about using this type with geodetic data, including examples, see Section 6.2.4. For information about creating three-dimensional optimized rectangles, see Section 1.11.3.</p>
1003 or 2003	4	Circle type. Described by three distinct non-colinear points, all on the circumference of the circle.
4	$n > 1$	<p>Compound line string with some vertices connected by straight line segments and some by circular arcs. The value n in the Interpretation column specifies the number of contiguous subelements that make up the line string.</p> <p>The next n triplets in the SDO_ELEM_INFO array describe each of these subelements. The subelements can only be of SDO_ETYPE 2. The last point of a subelement is the first point of the next subelement, and must not be repeated.</p> <p>See Section 2.7.3 and Figure 2–5 for an example of a compound line string geometry.</p>
1005 or 2005	$n > 1$	<p>Compound polygon with some vertices connected by straight line segments and some by circular arcs. The value n in the Interpretation column specifies the number of contiguous subelements that make up the polygon.</p> <p>The next n triplets in the SDO_ELEM_INFO array describe each of these subelements. The subelements can only be of SDO_ETYPE 2. The end point of a subelement is the start point of the next subelement, and it must not be repeated. The start and end points of the polygon must be exactly the same point (tolerance is ignored).</p> <p>See Section 2.7.4 and Figure 2–6 for an example of a compound polygon geometry.</p>
1006 or 2006	$n > 1$	<p>Surface consisting of one or more polygons, with each edge shared by no more than two polygons. A surface contains an area but not a volume. The value n in the Interpretation column specifies the number of polygons that make up the surface.</p> <p>The next n triplets in the SDO_ELEM_INFO array describe each of these polygon subelements.</p> <p>A surface can be two-dimensional or three-dimensional. For an explanation of three-dimensional support in Spatial, see Section 1.11.</p>

Table 2–2 (Cont.) Values and Semantics in SDO_ELEM_INFO

SDO_ETYPE	SDO_INTERPRETATION	Meaning
1007	$n = 1$ or 3	<p>Solid consisting of multiple surfaces that are completely enclosed in a three-dimensional space, so that the solid has an interior volume. A solid element can have one exterior surface defined by the 1006 elements and zero or more interior boundaries defined by the 2006 elements. The value n in the Interpretation column must be 1 or 3.</p> <p>Subsequent triplets in the SDO_ELEM_INFO array describe the exterior 1006 and optional interior 2006 surfaces that make up the solid element.</p> <p>If n is 3, the solid is an <i>optimized box</i>, such that only two three-dimensional points are required to define it: one with minimum values for the box in the X, Y, and Z dimensions and another with maximum values for the box in the X, Y, and Z dimensions. For example: <code>SDO_GEOMETRY(3008, NULL, NULL, SDO_ELEM_INFO_ARRAY(1,1007,3), SDO_ORDINATE_ARRAY(1,1,1, 3,3,3))</code></p> <p>For an explanation of three-dimensional support in Spatial, see Section 1.11.</p>

2.2.5 SDO_ORDINATES

The SDO_ORDINATES attribute is defined using a varying length array (1048576) of NUMBER type that stores the coordinate values that make up the boundary of a spatial object. This array must always be used in conjunction with the SDO_ELEM_INFO varying length array. The values in the array are ordered by dimension. For example, a polygon whose boundary has four two-dimensional points is stored as {X1, Y1, X2, Y2, X3, Y3, X4, Y4, X1, Y1}. If the points are three-dimensional, then they are stored as {X1, Y1, Z1, X2, Y2, Z2, X3, Y3, Z3, X4, Y4, Z4, X1, Y1, Z1}. The number of dimensions associated with each point is stored as metadata in the xxx_SDO_GEOM_METADATA views, described in [Section 2.8](#).

The values in the SDO_ORDINATES array must all be valid and non-null. There are no special values used to delimit elements in a multielement geometry. The start and end points for the sequence describing a specific element are determined by the STARTING_OFFSET values for that element and the next element in the SDO_ELEM_INFO array, as explained in [Section 2.2.4](#). The offset values start at 1. SDO_ORDINATES(1) is the first ordinate of the first point of the first element.

2.2.6 Usage Considerations

You should use the SDO_GTYPE values as shown in [Table 2–1](#); however, Spatial does not check or enforce all geometry consistency constraints. Spatial does check the following:

- For SDO_GTYPE values *d001* and *d005*, any subelement not of SDO_ETYPE 1 is ignored.
- For SDO_GTYPE values *d002* and *d006*, any subelement not of SDO_ETYPE 2 or 4 is ignored.
- For SDO_GTYPE values *d003* and *d007*, any subelement not of SDO_ETYPE 3 or 5 is ignored. (This includes SDO_ETYPE variants 1003, 2003, 1005, and 2005, which are explained in [Section 2.2.4](#)).

The [SDO_GEOM.VALIDATE_GEOMETRY_WITH_CONTEXT](#) function can be used to evaluate the consistency of a single geometry object or of all geometry objects in a specified feature table.

2.3 SDO_GEOMETRY Methods

The SDO_GEOMETRY object type (described in [Section 2.2](#)) has methods (member functions) that retrieve information about a geometry object. [Table 2–3](#) lists these methods.

Table 2–3 SDO_GEOMETRY Methods

Name	Returns	Description
Get_Dims	NUMBER	Returns the number of dimensions of a geometry object, as specified in its SDO_GTYPE value. In Oracle Spatial, the Get_Dims and ST_CoordDim methods return the same result.
Get_GType	NUMBER	Returns the geometry type of a geometry object, as specified in its SDO_GTYPE value.
Get_LRS_Dim	NUMBER	Returns the measure dimension of an LRS geometry object, as specified in its SDO_GTYPE value. A return value of 0 indicates that the geometry is a standard (non-LRS) geometry, or is an LRS geometry in the format before release 9.0.1 and with measure as the default (last) dimension; 3 indicates that the third dimension contains the measure information; 4 indicates that the fourth dimension contains the measure information.
Get_WKB	BLOB	Returns the well-known binary (WKB) format of a geometry object. (The returned object does not include any SRID information.)
Get_WKT	CLOB	Returns the well-known text (WKT) format (explained in Section 6.8.1.1) of a geometry object. (The returned object does not include any SRID information.)
ST_CoordDim	NUMBER	Returns the coordinate dimension (as defined by the ISO/IEC SQL Multimedia standard) of a geometry object. In Oracle Spatial, the Get_Dims and ST_CoordDim methods return the same result.
ST_IsValid	NUMBER	Returns 0 if a geometry object is invalid or 1 if it is valid. (The ISO/IEC SQL Multimedia standard uses the term <i>well formed</i> for <i>valid</i> in this context.) This method uses 0.001 as the tolerance value. (Tolerance is explained in Section 1.5.5 .) To specify a different tolerance value or to learn more about why a geometry is invalid, use the SDO_GEOM.VALIDATE_GEOMETRY_WITH_CONTEXT function, which is documented in Chapter 24 .

[Example 2–2](#) shows most of the SDO_GEOMETRY methods. (The Get_WKB method is not included because its output cannot be displayed by SQL*Plus.)

Example 2–2 SDO_GEOMETRY Methods

```
SELECT c.shape.Get_Dims()
   FROM cola_markets c WHERE c.name = 'cola_b';
```

```
C.SHAPE.GET_DIMS()
-----
                2
```

```
SELECT c.shape.Get_GType()
       FROM cola_markets c WHERE c.name = 'cola_b';
```

```
C.SHAPE.GET_GTYPE()
-----
3
```

```
SELECT a.route_geometry.Get_LRS_Dim()
       FROM lrs_routes a WHERE a.route_id = 1;
```

```
A.ROUTE_GEOMETRY.GET_LRS_DIM()
-----
3
```

```
SELECT c.shape.Get_WKT()
       FROM cola_markets c WHERE c.name = 'cola_b';
```

```
C.SHAPE.GET_WKT()
-----
POLYGON ((5.0 1.0, 8.0 1.0, 8.0 6.0, 5.0 7.0, 5.0 1.0))
```

```
SELECT c.shape.ST_CoordDim()
       FROM cola_markets c WHERE c.name = 'cola_b';
```

```
C.SHAPE.ST_COORDDIM()
-----
2
```

```
SELECT c.shape.ST_IsValid()
       FROM cola_markets c WHERE c.name = 'cola_b';
```

```
C.SHAPE.ST_ISVALID()
-----
1
```

2.4 SDO_GEOMETRY Constructors

The SDO_GEOMETRY object type (described in [Section 2.2](#)) has constructors that create a geometry object from a well-known text (WKT) string in CLOB or VARCHAR2 format, or from a well-known binary (WKB) object in BLOB format. The following constructor formats are available:

```
SDO_GEOMETRY(wkt CLOB, srid NUMBER DEFAULT NULL);
SDO_GEOMETRY(wkt VARCHAR2, srid NUMBER DEFAULT NULL);
SDO_GEOMETRY(wkb BLOB, srid NUMBER DEFAULT NULL);
```

If the created geometry is inserted into a table, the SRID value used with the constructor must match the SDO_SRID value of the geometries in the table.

The following simple example constructs a point geometry using a well-known text string. (In a WKT, spaces separate ordinates of a vertex, and commas separate vertices.)

```
SELECT SDO_GEOMETRY('POINT(-79 37)') FROM DUAL;
```

```
SDO_GEOMETRY('POINT(-7937)')(SDO_GTYPE, SDO_SRID, SDO_POINT(X, Y, Z), SDO_ELEM_I
-----
SDO_GEOMETRY(2001, NULL, SDO_POINT_TYPE(-79, 37, NULL), NULL, NULL)
```

[Example 2-3](#) shows SDO_GEOMETRY constructors that create geometry objects, insert the objects into a table, and display the objects that were added to the table.

Example 2-3 SDO_GEOMETRY Constructors to Create Geometries

```

DECLARE
  cola_b_wkb BLOB;
  cola_b_wkt_clob CLOB;
  cola_b_wkt_varchar VARCHAR2(255);
  cola_b_geom SDO_GEOMETRY;

BEGIN
  -- Get cola_b geometry into CLOB, VARCHAR2, and BLOB objects,
  -- for use by the constructor.
  SELECT c.shape.Get_WKT() INTO cola_b_wkt_clob
     FROM cola_markets c WHERE c.name = 'cola_b';
  cola_b_wkt_varchar := cola_b_wkt_clob;
  SELECT c.shape.Get_WKB() INTO cola_b_wkb
     FROM cola_markets c WHERE c.name = 'cola_b';

  -- Use some SDO_GEOMETRY constructors;
  -- insert 3 geometries into the table; display the geometries later.
  cola_b_geom := SDO_GEOMETRY(cola_b_wkt_clob);
  INSERT INTO cola_markets VALUES (101, 'cola_b_from_clob', cola_b_geom);
  cola_b_geom := SDO_GEOMETRY(cola_b_wkt_varchar);
  INSERT INTO cola_markets VALUES (102, 'cola_b_from_varchar', cola_b_geom);
  cola_b_geom := SDO_GEOMETRY(cola_b_wkb);
  INSERT INTO cola_markets VALUES (103, 'cola_b_from_wkb', cola_b_geom);
END;
/

PL/SQL procedure successfully completed.

-- Display the geometries created using SDO_GEOMETRY constructors.
-- All three geometries are identical.
SELECT name, shape FROM cola_markets WHERE mkt_id > 100;

NAME
-----
SHAPE(SDO_GTYPE, SDO_SRID, SDO_POINT(X, Y, Z), SDO_ELEM_INFO, SDO_ORDINATES)
-----
cola_b_from_clob
SDO_GEOMETRY(2003, NULL, NULL, SDO_ELEM_INFO_ARRAY(1, 1003, 1), SDO_ORDINATE_ARR
AY(5, 1, 8, 1, 8, 6, 5, 7, 5, 1))

cola_b_from_varchar
SDO_GEOMETRY(2003, NULL, NULL, SDO_ELEM_INFO_ARRAY(1, 1003, 1), SDO_ORDINATE_ARR
AY(5, 1, 8, 1, 8, 6, 5, 7, 5, 1))

cola_b_from_wkb
SDO_GEOMETRY(2003, NULL, NULL, SDO_ELEM_INFO_ARRAY(1, 1003, 1), SDO_ORDINATE_ARR
AY(5, 1, 8, 1, 8, 6, 5, 7, 5, 1))

```

2.5 TIN-Related Object Types

This section describes the following object types related to support for triangulated irregular networks (TINs):

- SDO_TIN

- SDO_TIN_BLK_TYPE
- SDO_TIN_BLK

2.5.1 SDO_TIN Object Type

The description of a TIN is stored in a single row, in a single column of object type SDO_TIN in a user-defined table. The object type SDO_TIN is defined as:

```
CREATE TYPE sdo_tin AS OBJECT
  (base_table      VARCHAR2(70),
   base_table_col  VARCHAR2(1024),
   tin_id          NUMBER,
   blk_table       VARCHAR2(70),
   ptn_params      VARCHAR2(1024),
   tin_extent      SDO_GEOMETRY,
   tin_tol         NUMBER,
   tin_tot_dimensions NUMBER,
   tin_domain      SDO_ORGSCL_TYPE,
   tin_break_lines SDO_GEOMETRY,
   tin_stop_lines  SDO_GEOMETRY,
   tin_void_rgns   SDO_GEOMETRY,
   tin_val_attr_tables SDO_STRING_ARRAY,
   tin_other_attrs XMLTYPE);
```

The SDO_TIN type has the attributes shown in [Table 2–4](#).

Table 2–4 SDO_TIN Type Attributes

Attribute	Explanation
BASE_TABLE	Name of the base table containing a column of type SDO_TIN
BASE_TABLE_COL	Name of the column of type SDO_TIN in the base table
TIN_ID	ID number for the TIN. (This unique ID number is generated by Spatial. It is unique within the schema for base tables containing a column of type SDO_TIN.)
BLK_TABLE	Name of the table that contains information about each block in the TIN. This table contains the columns shown in Table 2–5 .
PTN_PARAMS	Parameters for partitioning the TIN
TIN_EXTENT	SDO_GEOMETRY object representing the spatial extent of the TIN (the minimum bounding object enclosing all objects in the TIN)
TIN_TOL	Tolerance value for objects in the TIN. (For information about spatial tolerance, see Section 1.5.5)
TIN_TOT_DIMENSIONS	Total number of dimensions in the TIN. Includes spatial dimensions and any nonspatial dimensions, up to a maximum total of 9.
TIN_DOMAIN	(Not currently used.)
TIN_BREAK_LINES	(Not currently used.)
TIN_STOP_LINES	(Not currently used.)
TIN_VOID_RGNS	(Not currently used.)
TIN_VAL_ATTR_TABLES	SDO_STRING_ARRAY object specifying the names of any value attribute tables for the TIN. Type SDO_STRING_ARRAY is defined as VARRAY(1048576) OF VARCHAR2(32).

Table 2–4 (Cont.) SDO_TIN Type Attributes

Attribute	Explanation
TIN_OTHER_ATTRS	XMLTYPE object specifying any other attributes of the TIN

Figure 2–2 shows the storage model for TIN data, in which the TIN block table (specified in the BLK_TABLE attribute of the SDO_TIN type) stores the blocks associated with the SDO_TIN object.

Figure 2–2 Storage of TIN Data

Spatial table containing TIN data, for each row:

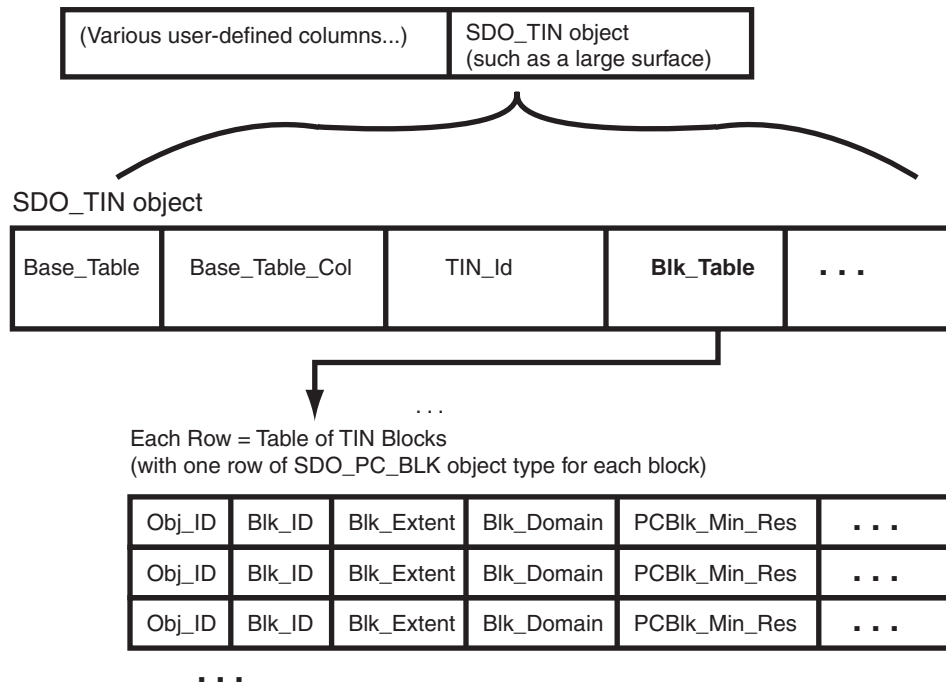

The TIN block table contains the columns shown in Table 2–5.

Table 2–5 Columns in the TIN Block Table

Column Name	Data Type	Purpose
BLK_ID	NUMBER	ID number of the block.
BLK_EXTENT	SDO_GEOMETRY	Spatial extent of the block.
BLK_DOMAIN	SDO_ORGSLD_TYPE	(Not currently used.)

Table 2–5 (Cont.) Columns in the TIN Block Table

Column Name	Data Type	Purpose
PCBLK_MIN_RES	NUMBER	For point cloud data, the minimum resolution level at which the block is visible in a query. The block is retrieved only if the query window intersects the spatial extent of the block and if the minimum - maximum resolution interval of the block intersects the minimum - maximum resolution interval of the query. Usually, lower values mean farther from the view point, and higher values mean closer to the view point.
PCBLK_MAX_RES	NUMBER	For point cloud data, the maximum resolution level at which the block is visible in a query. The block is retrieved only if the query window intersects the spatial extent of the block and if the minimum - maximum resolution interval of the block intersects the minimum - maximum resolution interval of the query. Usually, lower values mean farther from the view point, and higher values mean closer to the view point.
NUM_POINTS	NUMBER	For point cloud data, the total number of points in the POINTS BLOB
NUM_UNSORTED_POINTS	NUMBER	For point cloud data, the number of unsorted points in the POINTS BLOB
PT_SORT_DIM	NUMBER	For point cloud data, the number of spatial dimensions for the points (2 or 3)
POINTS	BLOB	For point cloud data, BLOB containing the points. Consists of an array of points, with the following information for each point: <ul style="list-style-type: none"> ▪ d 8-byte IEEE doubles, where d is the point cloud total number of dimensions ▪ 4-byte big-endian integer for the BLK_ID value ▪ 4-byte big-endian integer for the PT_ID value
TR_LVL	NUMBER	(Not currently used.)
TR_RES	NUMBER	(Not currently used.)
NUM_TRIANGLES	NUMBER	Number of triangles in the TRIANGLES BLOB.
TR_SORT_DIM	NUMBER	(Not currently used.)
TRIANGLES	BLOB	BLOB containing the triangles. Consists of an array of triangles for the block: <ul style="list-style-type: none"> ▪ Each triangle is specified by three vertices. ▪ Each vertex is specified by the pair (BLK_ID, PT_ID), with each value being a 4-byte big-endian integer.

For each BLOB in the POINTS column of the TIN block table:

- The total size is $(tdim+1)*8$, where $tdim$ is the total dimensionality of each block.
- The total size should be less than 5 MB for Oracle Database Release 11.1.0.6 or earlier; it should be less than 12 MB for Oracle Database Release 11.1.0.7 or later.

You can use an attribute name in a query on an object of SDO_TIN. [Example 2–4](#) shows part of a SELECT statement that queries the TIN_EXTENT attribute of the TERRAIN column of a hypothetical LANDSCAPES table.

Example 2-4 SDO_TIN Attribute in a Query

```
SELECT l.terrain.tin_extent FROM landscapes l WHERE ...;
```

2.5.2 SDO_TIN_BLK_TYPE and SDO_TIN_BLK Object Types

When you perform a clip operation using the [SDO_TIN_PKG.CLIP_TIN](#) function, an object of SDO_TIN_BLK_TYPE is returned, which is defined as TABLE OF SDO_TIN_BLK.

The attributes of the SDO_TIN_BLK object type are the same as the columns in the TIN block table, which is described in [Table 2-5](#) in [Section 2.5.2](#).

2.6 Point Cloud-Related Object Types

This section describes the following object types related to support for point clouds:

- SDO_PC
- SDO_PC_BLK

2.6.1 SDO_PC Object Type

The description of a point cloud is stored in a single row, in a single column of object type SDO_PC in a user-defined table. The object type SDO_PC is defined as:

```
CREATE TYPE sdo_pc AS OBJECT
  (base_table      VARCHAR2(70),
   base_table_col  VARCHAR2(1024),
   pc_id           NUMBER,
   blk_table       VARCHAR2(70),
   ptn_params      VARCHAR2(1024),
   pc_extent       SDO_GEOMETRY,
   pc_tol          NUMBER,
   pc_tot_dimensions NUMBER,
   pc_domain       SDO_ORGSCL_TYPE,
   pc_val_attr_tables SDO_STRING_ARRAY,
   pc_other_attrs  XMLTYPE);
```

The SDO_PC type has the attributes shown in [Table 2-6](#).

Table 2-6 SDO_PC Type Attributes

Attribute	Explanation
BASE_TABLE	Name of the base table containing a column of type SDO_PC
BASE_TABLE_COL	Name of the column of type SDO_PC in the base table
PC_ID	ID number for the point cloud. (This unique ID number is generated by Spatial. It is unique within the schema for base tables containing a column of type SDO_PC.)
BLK_TABLE	Name of the table that contains information about each block in the point cloud. This table contains the columns shown in Table 2-7 .
PTN_PARAMS	Parameters for partitioning the point cloud
PC_EXTENT	SDO_GEOMETRY object representing the spatial extent of the point cloud (the minimum bounding object enclosing all objects in the point cloud)
PC_TOL	Tolerance value for points in the point cloud. (For information about spatial tolerance, see Section 1.5.5 .)

Table 2–6 (Cont.) SDO_PC Type Attributes

Attribute	Explanation
PC_TOT_DIMENSIONS	Total number of dimensions in the point cloud. Includes spatial dimensions and any nonspatial dimensions, up to a maximum total of 9.
PC_DOMAINS	(Not currently used.)
PC_VAL_ATTR_TABLES	SDO_STRING_ARRAY object specifying the names of any value attribute tables for the point cloud. Type SDO_STRING_ARRAY is defined as <code>VARRAY(1048576) OF VARCHAR2(32)</code> .
PC_OTHER_ATTRS	XMLTYPE object specifying any other attributes of the point cloud

The point cloud block table (specified in the `BLK_TABLE` attribute of the `SDO_PC` type) contains the columns shown in [Table 2–7](#).

Table 2–7 Columns in the Point Cloud Block Table

Column Name	Data Type	Purpose
OBJ_ID	NUMBER	ID number of the point cloud object.
BLK_ID	NUMBER	ID number of the block.
BLK_EXTENT	SDO_GEOMETRY	Spatial extent of the block.
BLK_DOMAIN	SDO_ORGSCL_TYPE	(Not currently used.)
PCBLK_MIN_RES	NUMBER	For point cloud data, the minimum resolution level at which the block is visible in a query. The block is retrieved only if the query window intersects the spatial extent of the block and if the minimum - maximum resolution interval of the block intersects the minimum - maximum resolution interval of the query. Usually, lower values mean farther from the view point, and higher values mean closer to the view point.
PCBLK_MAX_RES	NUMBER	For point cloud data, the maximum resolution level at which the block is visible in a query. The block is retrieved only if the query window intersects the spatial extent of the block and if the minimum - maximum resolution interval of the block intersects the minimum - maximum resolution interval of the query. Usually, lower values mean farther from the view point, and higher values mean closer to the view point.
NUM_POINTS	NUMBER	For point cloud data, the total number of points in the POINTS BLOB
NUM_UNSORTED_POINTS	NUMBER	For point cloud data, the number of unsorted points in the POINTS BLOB
PT_SORT_DIM	NUMBER	Number of the dimension (1 for the first dimension, 2 for the second dimension, and so on) on which the points are sorted.
POINTS	BLOB	BLOB containing the points. Consists of an array of points, with the following information for each point: <ul style="list-style-type: none"> ▪ d 8-byte IEEE doubles, where d is the <code>PC_TOT_DIMENSIONS</code> value ▪ 4-byte big-endian integer for the <code>BLK_ID</code> value ▪ 4-byte big-endian integer for the <code>PT_ID</code> value

You can use an attribute name in a query on an object of SDO_PC. [Example 2-5](#) shows part of a SELECT statement that queries the PC_EXTENT attribute of the OCEAN_FLOOR column of a hypothetical OCEAN_FLOOR_MODEL table.

Example 2-5 SDO_PC Attribute in a Query

```
SELECT o.ocean_floor.pc_extent FROM ocean_floor_model o WHERE ...;
```

2.6.2 SDO_PC_BLK_TYPE and SDO_PC_BLK Object Type

When you perform a clip operation using the [SDO_PC_PKG.CLIP_PC](#) function, an object of SDO_PC_BLK_TYPE is returned, which is defined as TABLE OF SDO_PC_BLK.

The attributes of the SDO_PC_BLK object type are the same as the columns in the point cloud block table, which is described in [Table 2-7](#) in [Section 2.6.1](#).

2.7 Geometry Examples

This section contains examples of many geometry types:

- [Section 2.7.1, "Rectangle"](#)
- [Section 2.7.2, "Polygon with a Hole"](#)
- [Section 2.7.3, "Compound Line String"](#)
- [Section 2.7.4, "Compound Polygon"](#)
- [Section 2.7.5, "Point"](#)
- [Section 2.7.6, "Oriented Point"](#)
- [Section 2.7.7, "Type 0 \(Zero\) Element"](#)
- [Section 2.7.8, "Several Two-Dimensional Geometry Types"](#)

2.7.1 Rectangle

[Figure 2-3](#) illustrates the rectangle that represents cola_a in the example in [Section 2.1](#).

Figure 2-3 Rectangle

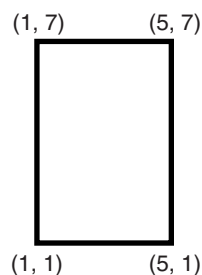

In the SDO_GEOMETRY definition of the geometry illustrated in [Figure 2-3](#):

- SDO_GTYPE = 2003. The 2 indicates two-dimensional, and the 3 indicates a polygon.
- SDO_SRID = NULL.

- SDO_POINT = NULL.
- SDO_ELEM_INFO = (1, 1003, 3). The final 3 in 1,1003,3 indicates that this is a rectangle. Because it is a rectangle, only two ordinates are specified in SDO_ORDINATES (lower-left and upper-right).
- SDO_ORDINATES = (1,1, 5,7). These identify the lower-left and upper-right ordinates of the rectangle.

Example 2-6 shows a SQL statement that inserts the geometry illustrated in Figure 2-3 into the database.

Example 2-6 SQL Statement to Insert a Rectangle

```
INSERT INTO cola_markets VALUES(
  1,
  'cola_a',
  SDO_GEOMETRY(
    2003, -- two-dimensional polygon
    NULL,
    NULL,
    SDO_ELEM_INFO_ARRAY(1,1003,3), -- one rectangle (1003 = exterior)
    SDO_ORDINATE_ARRAY(1,1, 5,7) -- only 2 points needed to
      -- define rectangle (lower left and upper right) with
      -- Cartesian-coordinate data
  )
);
```

2.7.2 Polygon with a Hole

Figure 2-4 illustrates a polygon consisting of two elements: an exterior polygon ring and an interior polygon ring. The inner element in this example is treated as a void (a hole).

Figure 2-4 Polygon with a Hole

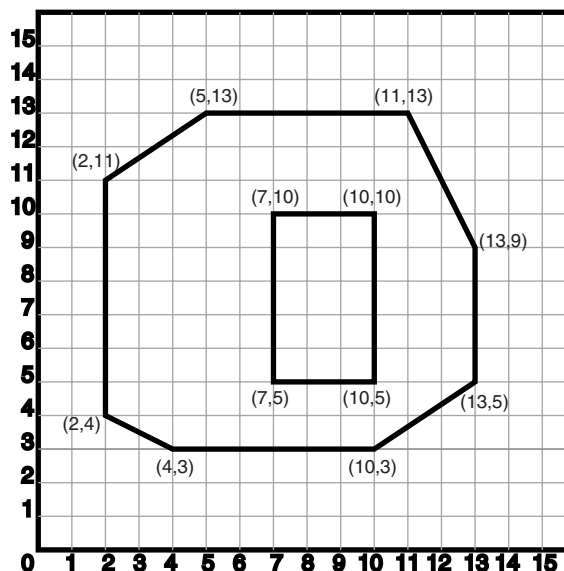

In the SDO_GEOMETRY definition of the geometry illustrated in Figure 2-4:

- SDO_GTYPE = 2003. The 2 indicates two-dimensional, and the 3 indicates a polygon.
- SDO_SRID = NULL.
- SDO_POINT = NULL.
- SDO_ELEM_INFO = (1,1003,1, 19,2003,1). There are two triplet elements: 1,1003,1 and 19,2003,1.
 1003 indicates that the element is an exterior polygon ring; 2003 indicates that the element is an interior polygon ring.
 19 indicates that the second element (the interior polygon ring) ordinate specification starts at the 19th number in the SDO_ORDINATES array (that is, 7, meaning that the first point is 7,5).
- SDO_ORDINATES = (2,4, 4,3, 10,3, 13,5, 13,9, 11,13, 5,13, 2,11, 2,4, 7,5, 7,10, 10,10, 10,5, 7,5).
- The area (SDO_GEOM.SDO_AREA function) of the polygon is the area of the exterior polygon minus the area of the interior polygon. In this example, the area is 84 (99 - 15).
- The perimeter (SDO_GEOM.SDO_LENGTH function) of the polygon is the perimeter of the exterior polygon plus the perimeter of the interior polygon. In this example, the perimeter is 52.9193065 (36.9193065 + 16).

Example 2-7 shows a SQL statement that inserts the geometry illustrated in Figure 2-4 into the database.

Example 2-7 SQL Statement to Insert a Polygon with a Hole

```
INSERT INTO cola_markets VALUES(
  10,
  'polygon_with_hole',
  SDO_GEOMETRY(
    2003, -- two-dimensional polygon
    NULL,
    NULL,
    SDO_ELEM_INFO_ARRAY(1,1003,1, 19,2003,1), -- polygon with hole
    SDO_ORDINATE_ARRAY(2,4, 4,3, 10,3, 13,5, 13,9, 11,13, 5,13, 2,11, 2,4,
      7,5, 7,10, 10,10, 10,5, 7,5)
  )
);
```

An example of such a "polygon with a hole" might be a land mass (such as a country or an island) with a lake inside it. Of course, an actual land mass might have many such interior polygons: each one would require a triplet element in SDO_ELEM_INFO, plus the necessary ordinate specification.

Exterior and interior rings cannot be nested. For example, if a country has a lake and there is an island in the lake (and perhaps a lake on the island), a separate polygon must be defined for the island; the island cannot be defined as an interior polygon ring within the interior polygon ring of the lake.

In a **multipolygon** (polygon collection), rings must be grouped by polygon, and the first ring of each polygon must be the exterior ring. For example, consider a polygon collection that contains two polygons (A and B):

- Polygon A (one interior "hole"): exterior ring A0, interior ring A1
- Polygon B (two interior "holes"): exterior ring B0, interior ring B1, interior ring B2

The elements in SDO_ELEM_INFO and SDO_ORDINATES must be in one of the following orders (depending on whether you specify Polygon A or Polygon B first):

- A0, A1; B0, B1, B2
- B0, B1, B2; A0, A1

2.7.3 Compound Line String

Figure 2–5 illustrates a crescent-shaped object represented as a compound line string made up of one straight line segment and one circular arc. Four points are required to represent this shape: points (10,10) and (10,14) describe the straight line segment, and points (10,14), (6,10), and (14,10) describe the circular arc.

Figure 2–5 Compound Line String

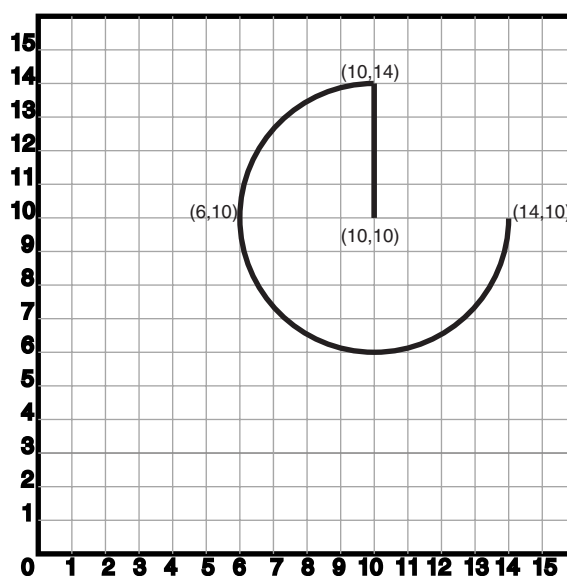

In the SDO_GEOMETRY definition of the geometry illustrated in Figure 2–5:

- SDO_GTYPE = 2002. The first 2 indicates two-dimensional, and the second 2 indicates one or more line segments.
- SDO_SRID = NULL.
- SDO_POINT = NULL.
- SDO_ELEM_INFO = (1,4,2, 1,2,1, 3,2,2). There are three triplet elements: 1,4,2, 1,2,1, and 3,2,2.

The first triplet indicates that this element is a compound line string made up of two subelement line strings, which are described with the next two triplets.

The second triplet indicates that the line string is made up of straight line segments and that the ordinates for this line string start at offset 1. The end point of this line string is determined by the starting offset of the second line string, 3 in this instance.

The third triplet indicates that the second line string is made up of circular arcs with ordinates starting at offset 3. The end point of this line string is determined by the starting offset of the next element or the current length of the SDO_ORDINATES array, if this is the last element.

- SDO_ORDINATES = (10,10, 10,14, 6,10, 14,10).

Example 2-8 shows a SQL statement that inserts the geometry illustrated in Figure 2-5 into the database.

Example 2-8 SQL Statement to Insert a Compound Line String

```
INSERT INTO cola_markets VALUES(
  11,
  'compound_line_string',
  SDO_GEOMETRY(
    2002,
    NULL,
    NULL,
    SDO_ELEM_INFO_ARRAY(1,4,2, 1,2,1, 3,2,2), -- compound line string
    SDO_ORDINATE_ARRAY(10,10, 10,14, 6,10, 14,10)
  )
);
```

2.7.4 Compound Polygon

Figure 2-6 illustrates an ice cream cone-shaped object represented as a compound polygon made up of one straight line segment and one circular arc. Five points are required to represent this shape: points (6,10), (10,1), and (14,10) describe one acute angle-shaped line string, and points (14,10), (10,14), and (6,10) describe the circular arc. The starting point of the line string and the ending point of the circular arc are the same point (6,10). The SDO_ELEM_INFO array contains three triplets for this compound line string. These triplets are {(1,1005,2), (1,2,1), (5,2,2)}.

Figure 2-6 Compound Polygon

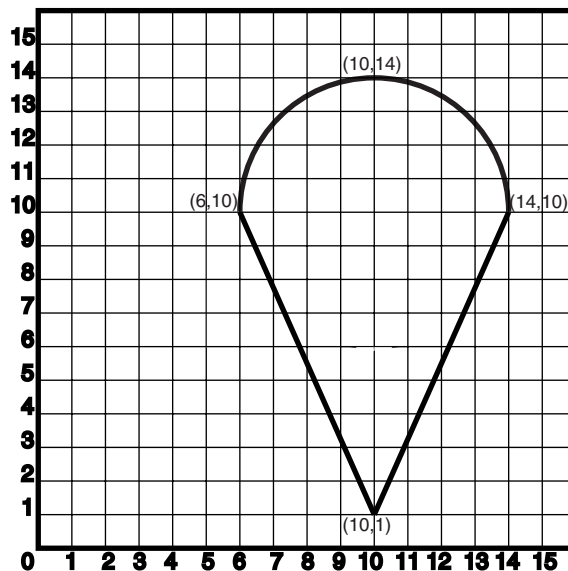

In the SDO_GEOMETRY definition of the geometry illustrated in Figure 2-6:

- SDO_GTYPE = 2003. The 2 indicates two-dimensional, and the 3 indicates a polygon.
- SDO_SRID = NULL.
- SDO_POINT = NULL.

- SDO_ELEM_INFO = (1,1005,2, 1,2,1, 5,2,2). There are three triplet elements: 1,1005,2, 1,2,1, and 5,2,2.

The first triplet indicates that this element is a compound polygon made up of two subelement line strings, which are described using the next two triplets.

The second triplet indicates that the first subelement line string is made up of straight line segments and that the ordinates for this line string start at offset 1. The end point of this line string is determined by the starting offset of the second line string, 5 in this instance. Because the vertices are two-dimensional, the coordinates for the end point of the first line string are at ordinates 5 and 6.

The third triplet indicates that the second subelement line string is made up of a circular arc with ordinates starting at offset 5. The end point of this line string is determined by the starting offset of the next element or the current length of the SDO_ORDINATES array, if this is the last element.

- SDO_ORDINATES = (6,10, 10,1, 14,10, 10,14, 6,10).

[Example 2-9](#) shows a SQL statement that inserts the geometry illustrated in [Figure 2-6](#) into the database.

Example 2-9 SQL Statement to Insert a Compound Polygon

```
INSERT INTO cola_markets VALUES(
  12,
  'compound_polygon',
  SDO_GEOMETRY(
    2003, -- two-dimensional polygon
    NULL,
    NULL,
    SDO_ELEM_INFO_ARRAY(1,1005,2, 1,2,1, 5,2,2), -- compound polygon
    SDO_ORDINATE_ARRAY(6,10, 10,1, 14,10, 10,14, 6,10)
  )
);
```

2.7.5 Point

[Figure 2-7](#) illustrates a point-only geometry at coordinates (12,14).

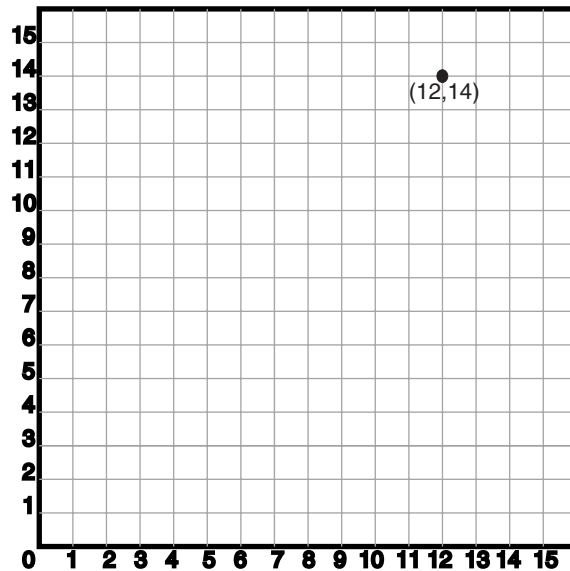
Figure 2–7 Point-Only Geometry

In the SDO_GEOMETRY definition of the geometry illustrated in [Figure 2–7](#):

- SDO_GTYPE = 2001. The 2 indicates two-dimensional, and the 1 indicates a single point.
- SDO_SRID = NULL.
- SDO_POINT = SDO_POINT_TYPE(12, 14, NULL). The SDO_POINT attribute is defined using the SDO_POINT_TYPE object type, because this is a point-only geometry.

For more information about the SDO_POINT attribute, see [Section 2.2.3](#).

- SDO_ELEM_INFO and SDO_ORDINATES are both NULL, as required if the SDO_POINT attribute is specified.

[Example 2–10](#) shows a SQL statement that inserts the geometry illustrated in [Figure 2–7](#) into the database.

Example 2–10 SQL Statement to Insert a Point-Only Geometry

```
INSERT INTO cola_markets VALUES(
  90,
  'point_only',
  SDO_GEOMETRY(
    2001,
    NULL,
    SDO_POINT_TYPE(12, 14, NULL),
    NULL,
    NULL));
```

You can search for point-only geometries based on the X, Y, and Z values in the SDO_POINT_TYPE specification. [Example 2–11](#) is a query that asks for all points whose first coordinate (the X value) is 12, and it finds the point that was inserted in [Example 2–10](#).

Example 2–11 Query for Point-Only Geometry Based on a Coordinate Value

```
SELECT * from cola_markets c WHERE c.shape.SDO_POINT.X = 12;
```



```

MKT_ID NAME
-----
SHAPE(SDO_GTYPE, SDO_SRID, SDO_POINT(X, Y, Z), SDO_ELEM_INFO, SDO_ORDINATES)
-----
          90 point_only
SDO_GEOMETRY(2001, NULL, SDO_POINT_TYPE(12, 14, NULL), NULL, NULL)

```

2.7.6 Oriented Point

An **oriented point** is a special type of point geometry that includes coordinates representing the locations of the point and a virtual end point, to indicate an orientation vector that can be used for rotating a symbol at the point or extending a label from the point. The main use for an oriented point is in map visualization and display applications that include symbols, such as a shield symbol to indicate a highway.

To specify an oriented point:

- Use an SDO_GTYPE value (explained in [Section 2.2.1](#)) for a point or multipoint geometry.
- Specify a null value for the SDO_POINT attribute.
- In the SDO_ELEM_INFO array (explained in [Section 2.2.4](#)), specify an additional triplet, with the second and third values (SDO_ETYPE and SDO_INTERPRETATION) as 1 and 0. For example, a triplet of 3,1,0 indicates that the point is an oriented point, with the third number in the SDO_ORDINATES array being the first coordinate, or x-axis value, of the end point reflecting the orientation vector for any symbol or label.
- In the SDO_ORDINATES array (explained in [Section 2.2.5](#)), specify the coordinates of the end point for the orientation vector from the point, with values between -1 and 1. The orientation start point is assumed to be (0,0), and it is translated to the location of the physical point to which it corresponds.

[Figure 2–8](#) illustrates an oriented point geometry at coordinates (12,14), with an orientation vector of approximately 34 degrees (counterclockwise from the x-axis), reflecting the orientation coordinates 0.3,0.2. (To have an orientation that more precisely matches a specific angle, refer to the cotangent or tangent values in the tables in a trigonometry textbook.) The orientation vector in this example goes from (0,0) to (0.3,0.2) and extends onward. Assuming $i=0.3$ and $j=0.2$, the angle in radians can be calculated as follows: $\text{angle in radians} = \arctan(j/i)$. The angle is then applied to the physical point associated with the orientation vector.

Figure 2–8 Oriented Point Geometry

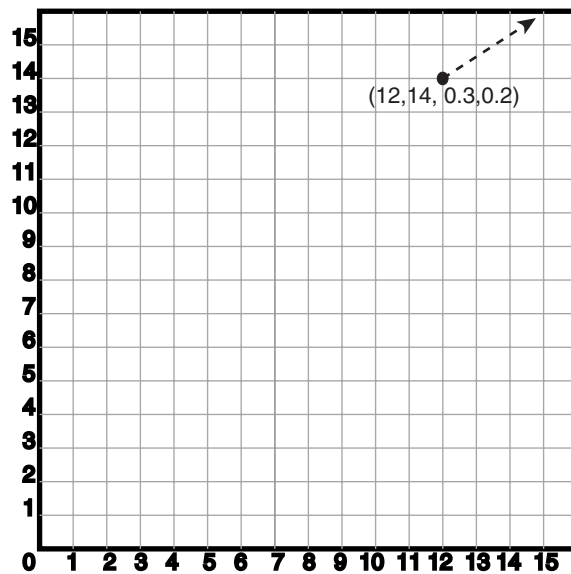

In the SDO_GEOMETRY definition of the geometry illustrated in [Figure 2–8](#):

- SDO_GTYPE = 2001. The 2 indicates two-dimensional, and the 1 indicates a single point.
- SDO_SRID = NULL.
- SDO_POINT = NULL.
- SDO_ELEM_INFO = (1,1,1, 3,1,0). The final 1,0 in 3,1,0 indicates that this is an oriented point.
- SDO_ORDINATES = (12,14, 0.3,0.2). The 12,14 identifies the physical coordinates of the point; and the 0.3,0.2 identifies the x and y coordinates (assuming 12,14 as the origin) of the end point of the orientation vector. The resulting orientation vector slopes upward at about a 34-degree angle.

[Example 2–12](#) shows a SQL statement that inserts the geometry illustrated in [Figure 2–8](#) into the database.

Example 2–12 SQL Statement to Insert an Oriented Point Geometry

```
INSERT INTO cola_markets VALUES(
  91,
  'oriented_point',
  SDO_GEOMETRY(
    2001,
    NULL,
    NULL,
    SDO_ELEM_INFO_ARRAY(1,1,1, 3,1,0),
    SDO_ORDINATE_ARRAY(12,14, 0.3,0.2)));
```

The following guidelines apply to the definition of an oriented point:

- The numbers defining the orientation vector must be between -1 and 1. (In [Example 2–12](#), these numbers are 0.3 and 0.2.)
- Multipoint oriented points are allowed (see [Example 2–13](#)), but the orientation information must follow the point being oriented.

The following considerations apply to the dimensionality of the orientation vector for an oriented point:

- A two-dimensional point has a two-dimensional orientation vector.
- A two-dimensional point with an LRS measure (SDO_GTYPE=3301) has a two-dimensional orientation vector.
- A three-dimensional point (SDO_GTYPE=3001) has a three-dimensional orientation vector.
- A three-dimensional point with an LRS measure (SDO_GTYPE=4401) has a three-dimensional orientation vector.
- A four-dimensional point (SDO_GTYPE=4001) has a three-dimensional orientation vector.

[Example 2-13](#) shows a SQL statement that inserts an oriented multipoint geometry into the database. The multipoint geometry contains two points, at coordinates (12,14) and (12, 10), with the two points having different orientation vectors. The statement is similar to the one in [Example 2-12](#), but in [Example 2-13](#) the second point has an orientation vector pointing down and to the left at 45 degrees (or, 135 degrees clockwise from the x-axis), reflecting the orientation coordinates -1,-1.

Example 2-13 SQL Statement to Insert an Oriented Multipoint Geometry

```
-- Oriented multipoint: 2 points, different orientations
INSERT INTO cola_markets VALUES(
  92,
  'oriented_multipoint',
  SDO_GEOMETRY(
    2005, -- Multipoint
    NULL,
    NULL,
    SDO_ELEM_INFO_ARRAY(1,1,1, 3,1,0, 5,1,1, 7,1,0),
    SDO_ORDINATE_ARRAY(12,14, 0.3,0.2, 12,10, -1,-1));
```

2.7.7 Type 0 (Zero) Element

Type 0 (zero) elements are used to model geometry types that are not supported by Oracle Spatial, such as curves and splines. A type 0 element has an SDO_ETYPE value of 0. (See [Section 2.2.4](#) for information about the SDO_ETYPE.) Type 0 elements are not indexed by Oracle Spatial, and they are ignored by Spatial functions and procedures.

Geometries with type 0 elements must contain at least one nonzero element, that is, an element with an SDO_ETYPE value that is not 0. The nonzero element should be an approximation of the unsupported geometry, and therefore it must have both:

- An SDO_ETYPE value associated with a geometry type supported by Spatial
- An SDO_INTERPRETATION value that is valid for the SDO_ETYPE value (see [Table 2-2](#))

(The SDO_INTERPRETATION value for the type 0 element can be any numeric value, and applications are responsible for determining the validity and significance of the value.)

The nonzero element is indexed by Spatial, and it will be returned by the spatial index.

The SDO_GTYPE value for a geometry containing a type 0 element must be set to the value for the geometry type of the nonzero element.

Figure 2–9 shows a geometry with two elements: a curve (unsupported geometry) and a rectangle (the nonzero element) that approximates the curve. The curve looks like the letter S, and the rectangle is represented by the dashed line.

Figure 2–9 Geometry with Type 0 (Zero) Element

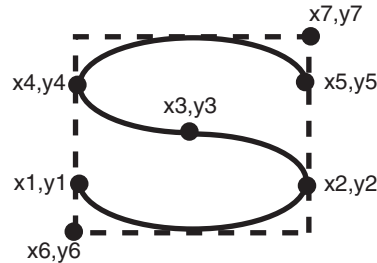

In the example shown in Figure 2–9:

- The SDO_GTYPE value for the geometry is 2003 (for a two-dimensional polygon).
- The SDO_ELEM_INFO array contains two triplets for this compound line string. For example, the triplets might be {(1,0,57), (11,1003,3)}. That is:

Ordinate Starting Offset (SDO_STARTING_OFFSET)	Element Type (SDO_ETYPE)	Interpretation (SDO_INTERPRETATION)
1	0	57
11	1003	3

In this example:

- The type 0 element has an SDO_ETYPE value of 0.
- The nonzero element (rectangle) has an SDO_ETYPE value of 1003, indicating an exterior polygon ring.
- The nonzero element has an SDO_STARTING_OFFSET value of 11 because ordinate x6 is the eleventh ordinate in the geometry.
- The type 0 element has an SDO_INTERPRETATION value whose significance is application-specific. In this example, the SDO_INTERPRETATION value is 57.
- The nonzero element has an SDO_INTERPRETATION value that is valid for the SDO_ETYPE of 1003. In this example, the SDO_INTERPRETATION value is 3, indicating a rectangle defined by two points (lower-left and upper-right).

Example 2–14 shows a SQL statement that inserts the geometry with a type 0 element (similar to the geometry illustrated in Figure 2–9) into the database. In the SDO_ORDINATE_ARRAY structure, the curve is defined by points (6,6), (12,6), (9,8), (6,10), and (12,10), and the rectangle is defined by points (6,4) and (12,12).

Example 2–14 SQL Statement to Insert a Geometry with a Type 0 Element

```
INSERT INTO cola_markets VALUES(
  13,
  'type_zero_element_geom',
  SDO_GEOMETRY(
    2003, -- two-dimensional polygon
    NULL,
```

```

        NULL,
        SDO_ELEM_INFO_ARRAY(1,0,57, 11,1003,3), -- 1st is type 0 element
        SDO_ORDINATE_ARRAY(6,6, 12,6, 9,8, 6,10, 12,10, 6,4, 12,12)
    )
);

```

2.7.8 Several Two-Dimensional Geometry Types

Example 2–15 creates a table and inserts various two-dimensional geometries, including multipoints (point clusters), multipolygons, and collections. At the end, it calls the `SDO_GEOM.VALIDATE_GEOMETRY_WITH_CONTEXT` function to validate the inserted geometries. Note that some geometries are deliberately invalid, and their descriptions include the string `INVALID`.

Example 2–15 SQL Statements to Insert Various Two-Dimensional Geometries

```

CREATE TABLE t1 (
    i NUMBER,
    d VARCHAR2(50),
    g SDO_GEOMETRY
);
INSERT INTO t1 (i, d, g)
VALUES (
    1,
    'Point',
    sdo_geometry (2001, null, null, sdo_elem_info_array (1,1,1),
        sdo_ordinate_array (10,5))
);
INSERT INTO t1 (i, d, g)
VALUES (
    2,
    'Line segment',
    sdo_geometry (2002, null, null, sdo_elem_info_array (1,2,1),
        sdo_ordinate_array (10,10, 20,10))
);
INSERT INTO t1 (i, d, g)
VALUES (
    3,
    'Arc segment',
    sdo_geometry (2002, null, null, sdo_elem_info_array (1,2,2),
        sdo_ordinate_array (10,15, 15,20, 20,15))
);
INSERT INTO t1 (i, d, g)
VALUES (
    4,
    'Line string',
    sdo_geometry (2002, null, null, sdo_elem_info_array (1,2,1),
        sdo_ordinate_array (10,25, 20,30, 25,25, 30,30))
);
INSERT INTO t1 (i, d, g)
VALUES (
    5,
    'Arc string',
    sdo_geometry (2002, null, null, sdo_elem_info_array (1,2,2),
        sdo_ordinate_array (10,35, 15,40, 20,35, 25,30, 30,35))
);
INSERT INTO t1 (i, d, g)
VALUES (
    6,
    'Compound line string',

```

```

        sdo_geometry (2002, null, null,
            sdo_elem_info_array (1,4,3, 1,2,1, 3,2,2, 7,2,1),
            sdo_ordinate_array (10,45, 20,45, 23,48, 20,51, 10,51))
    );
INSERT INTO t1 (i, d, g)
VALUES (
    7,
    'Closed line string',
    sdo_geometry (2002, null, null, sdo_elem_info_array (1,2,1),
        sdo_ordinate_array (10,55, 15,55, 20,60, 10,60, 10,55))
);
INSERT INTO t1 (i, d, g)
VALUES (
    8,
    'Closed arc string',
    sdo_geometry (2002, null, null, sdo_elem_info_array (1,2,2),
        sdo_ordinate_array (15,65, 10,68, 15,70, 20,68, 15,65))
);
INSERT INTO t1 (i, d, g)
VALUES (
    9,
    'Closed mixed line',
    sdo_geometry (2002, null, null, sdo_elem_info_array (1,4,2, 1,2,1, 7,2,2),
        sdo_ordinate_array (10,78, 10,75, 20,75, 20,78, 15,80, 10,78))
);
INSERT INTO t1 (i, d, g)
VALUES (
    10,
    'Self-crossing line',
    sdo_geometry (2002, null, null, sdo_elem_info_array (1,2,1),
        sdo_ordinate_array (10,85, 20,90, 20,85, 10,90, 10,85))
);
INSERT INTO t1 (i, d, g)
VALUES (
    11,
    'Polygon',
    sdo_geometry (2003, null, null, sdo_elem_info_array (1,1003,1),
        sdo_ordinate_array (10,105, 15,105, 20,110, 10,110, 10,105))
);
INSERT INTO t1 (i, d, g)
VALUES (
    12,
    'Arc polygon',
    sdo_geometry (2003, null, null, sdo_elem_info_array (1,1003,2),
        sdo_ordinate_array (15,115, 20,118, 15,120, 10,118, 15,115))
);
INSERT INTO t1 (i, d, g)
VALUES (
    13,
    'Compound polygon',
    sdo_geometry (2003, null, null, sdo_elem_info_array (1,1005,2, 1,2,1, 7,2,2),
        sdo_ordinate_array (10,128, 10,125, 20,125, 20,128, 15,130, 10,128))
);
INSERT INTO t1 (i, d, g)
VALUES (
    14,
    'Rectangle',
    sdo_geometry (2003, null, null, sdo_elem_info_array (1,1003,3),
        sdo_ordinate_array (10,135, 20,140))
);

```

```
INSERT INTO t1 (i, d, g)
VALUES (
  15,
  'Circle',
  sdo_geometry (2003, null, null, sdo_elem_info_array (1,1003,4),
    sdo_ordinate_array (15,145, 10,150, 20,150))
);
INSERT INTO t1 (i, d, g)
VALUES (
  16,
  'Point cluster',
  sdo_geometry (2005, null, null, sdo_elem_info_array (1,1,3),
    sdo_ordinate_array (50,5, 55,7, 60,5))
);
INSERT INTO t1 (i, d, g)
VALUES (
  17,
  'Multipoint',
  sdo_geometry (2005, null, null, sdo_elem_info_array (1,1,1, 3,1,1, 5,1,1),
    sdo_ordinate_array (65,5, 70,7, 75,5))
);
INSERT INTO t1 (i, d, g)
VALUES (
  18,
  'Multiline',
  sdo_geometry (2006, null, null, sdo_elem_info_array (1,2,1, 5,2,1),
    sdo_ordinate_array (50,15, 55,15, 60,15, 65,15))
);
INSERT INTO t1 (i, d, g)
VALUES (
  19,
  'Multiline - crossing',
  sdo_geometry (2006, null, null, sdo_elem_info_array (1,2,1, 5,2,1),
    sdo_ordinate_array (50,22, 60,22, 55,20, 55,25))
);
INSERT INTO t1 (i, d, g)
VALUES (
  20,
  'Multiarc',
  sdo_geometry (2006, null, null, sdo_elem_info_array (1,2,2, 7,2,2),
    sdo_ordinate_array (50,35, 55,40, 60,35, 65,35, 70,30, 75,35))
);
INSERT INTO t1 (i, d, g)
VALUES (
  21,
  'Multiline - closed',
  sdo_geometry (2006, null, null, sdo_elem_info_array (1,2,1, 9,2,1),
    sdo_ordinate_array (50,55, 50,60, 55,58, 50,55, 56,58, 60,55, 60,60, 56,58))
);
INSERT INTO t1 (i, d, g)
VALUES (
  22,
  'Multiarc - touching',
  sdo_geometry (2006, null, null, sdo_elem_info_array (1,2,2, 7,2,2),
    sdo_ordinate_array (50,65, 50,70, 55,68, 55,68, 60,65, 60,70))
);
INSERT INTO t1 (i, d, g)
VALUES (
  23,
  'Multipolygon - disjoint',
```

```

        sdo_geometry (2007, null, null, sdo_elem_info_array (1,1003,1, 11,1003,3),
            sdo_ordinate_array (50,105, 55,105, 60,110, 50,110, 50,105, 62,108, 65,112))
    );
INSERT INTO t1 (i, d, g)
VALUES (
    24,
    'Multipolygon - touching',
    sdo_geometry (2007, null, null, sdo_elem_info_array (1,1003,3, 5,1003,3),
        sdo_ordinate_array (50,115, 55,120, 55,120, 58,122))
);
INSERT INTO t1 (i, d, g)
VALUES (
    25,
    'Multipolygon - tangent * INVALID 13351',
    sdo_geometry (2007, null, null, sdo_elem_info_array (1,1003,3, 5,1003,3),
        sdo_ordinate_array (50,125, 55,130, 55,128, 60,132))
);
INSERT INTO t1 (i, d, g)
VALUES (
    26,
    'Multipolygon - multi-touch',
    sdo_geometry (2007, null, null, sdo_elem_info_array (1,1003,1, 17,1003,1),
        sdo_ordinate_array (50,95, 55,95, 53,96, 55,97, 53,98, 55,99, 50,99, 50,95,
            55,100, 55,95, 60,95, 60,100, 55,100))
);
INSERT INTO t1 (i, d, g)
VALUES (
    27,
    'Polygon with void',
    sdo_geometry (2003, null, null, sdo_elem_info_array (1,1003,3, 5,2003,3),
        sdo_ordinate_array (50,135, 60,140, 51,136, 59,139))
);
INSERT INTO t1 (i, d, g)
VALUES (
    28,
    'Polygon with void - reverse',
    sdo_geometry (2003, null, null, sdo_elem_info_array (1,2003,3, 5,1003,3),
        sdo_ordinate_array (51,146, 59,149, 50,145, 60,150))
);
INSERT INTO t1 (i, d, g)
VALUES (
    29,
    'Crescent (straight lines) * INVALID 13349',
    sdo_geometry (2003, null, null, sdo_elem_info_array (1,1003,1),
        sdo_ordinate_array (10,175, 10,165, 20,165, 15,170, 25,170, 20,165,
            30,165, 30,175, 10,175))
);
INSERT INTO t1 (i, d, g)
VALUES (
    30,
    'Crescent (arcs) * INVALID 13349',
    sdo_geometry (2003, null, null, sdo_elem_info_array (1,1003,2),
        sdo_ordinate_array (14,180, 10,184, 14,188, 18,184, 14,180, 16,182,
            14,184, 12,182, 14,180))
);
INSERT INTO t1 (i, d, g)
VALUES (
    31,
    'Heterogeneous collection',
    sdo_geometry (2004, null, null, sdo_elem_info_array (1,1,1, 3,2,1, 7,1003,1),

```



```

        sdo_ordinate_array (10,5, 10,10, 20,10, 10,105, 15,105, 20,110, 10,110,
            10,105))
    );
INSERT INTO t1 (i, d, g)
VALUES (
    32,
    'Polygon+void+island touch',
    sdo_geometry (2007, null, null,
        sdo_elem_info_array (1,1003,1, 11,2003,1, 31,1003,1),
        sdo_ordinate_array (50,168, 50,160, 55,160, 55,168, 50,168, 51,167,
            54,167, 54,161, 51,161, 51,162, 52,163, 51,164, 51,165, 51,166, 51,167,
            52,166, 52,162, 53,162, 53,166, 52,166))
    );
COMMIT;
SELECT i, d, SDO_GEOM.VALIDATE_GEOMETRY_WITH_CONTEXT (g, 0.5) FROM t1;

```

2.7.9 Three-Dimensional Geometry Types

[Example 2–16](#) creates several tables (POINTS3D, LINES3D, and POLYGONS3D), and inserts three-dimensional objects into each table as appropriate (points into POINTS3D; lines into LINES3D; and polygons, surfaces, and solids into POLYGONS3D). [Example 2–17](#) then creates the metadata and spatial indexes for the tables.

For information about support for three-dimensional geometries, see [Section 1.11](#).

Example 2–16 SQL Statements to Insert Three-Dimensional Geometries

```

create table points3d(id number, geometry sdo_geometry);
insert into points3d values(1, sdo_geometry(3001,null,
    sdo_point_type(0,0,0), null, null));
insert into points3d values(2, sdo_geometry(3001,null,
    sdo_point_type(1,1,1), null, null));
insert into points3d values(3, sdo_geometry(3001,null,
    sdo_point_type(0,1,1), null, null));
insert into points3d values(4, sdo_geometry(3001,null,
    sdo_point_type(0,0,1), null, null));
insert into points3d values(5, sdo_geometry(3001,null,
    sdo_point_type(1,1,0), null, null));
insert into points3d values(6, sdo_geometry(3001,null,
    sdo_point_type(1,0,1), null, null));
insert into points3d values(7, sdo_geometry(3001,null,
    sdo_point_type(1,0,0), null, null));
insert into points3d values(8, sdo_geometry(3001,null,
    sdo_point_type(0,1,0), null, null));
insert into points3d values(9, sdo_geometry(3005,null, null,
    sdo_elem_info_array(1,1,1, 4,1,1),
    sdo_ordinate_array(1,1,1, 0,0,0)));

create table lines3d(id number, geometry sdo_geometry);
insert into lines3d values(1, sdo_geometry(3002,null, null,
    sdo_elem_info_array(1,2,1),
    sdo_ordinate_array(1,1,1, 0,0,0)));
insert into lines3d values(2, sdo_geometry(3002,null, null,
    sdo_elem_info_array(1,2,1),
    sdo_ordinate_array(1,0,1, 0,1,0)));
insert into lines3d values(2, sdo_geometry(3002,null, null,
    sdo_elem_info_array(1,2,1),
    sdo_ordinate_array(0,1,1, 1,0,0)));
insert into lines3d values(3, sdo_geometry(3002,null, null,

```

```

        sdo_elem_info_array(1,2,1),
        sdo_ordinate_array(0,1,1, 1,0,0));
insert into lines3d values(4, sdo_geometry(3002,null, null,
        sdo_elem_info_array(1,2,1),
        sdo_ordinate_array(0,1,0, 1,0,1)));

create table polygons3d(id number, geometry sdo_geometry);

-- Simple Polygon
-- All points have to be on the same plane.
insert into polygons3d values(1,
SDO_Geometry (3003,NULL,NULL ,
  SDO_Elem_Info_Array(1,1003,1),
  SDO_Ordinate_Array(0.5,0.0,0.0,
0.5,1.0,0.0,
0.0,1.0,1.0,
0.0,0.0,1.0,
0.5,0.0,0.0
)));
insert into polygons3d values(2,
SDO_Geometry (3003,NULL,NULL ,
  SDO_Elem_Info_Array(1,1003,1),
  SDO_Ordinate_Array(6.0,6.0,6.0,
5.0,6.0,10.0,
3.0,4.0,8.0,
4.0,4.0,4.0,
6.0,6.0,6.0
)));
insert into polygons3d values(3,
SDO_Geometry (3007,NULL,NULL ,
  SDO_Elem_Info_Array(1,1003,1,16,1003,1),
  SDO_Ordinate_Array(6.0,6.0,6.0,
5.0,6.0,10.0,
3.0,4.0,8.0,
4.0,4.0,4.0,
6.0,6.0,6.0,
0.5,0.0,0.0,
0.5,1.0,0.0,
0.0,1.0,1.0,
0.0,0.0,1.0,
0.5,0.0,0.0
)));
-- Polygon with a Hole (same rules as 2D) plus all points on the same plane
insert into polygons3d values(4,
SDO_Geometry (3003,NULL,NULL ,
  SDO_Elem_Info_Array(1,1003,1,16,2003,1),
  SDO_Ordinate_Array(0.5,0.0,0.0,
0.5,1.0,0.0,
0.0,1.0,1.0,
0.0,0.0,1.0,
0.5,0.0,0.0,
0.25,0.5,0.5,
0.15,0.5,0.7,
0.15,0.6,0.7,
0.25,0.6,0.5,
0.25,0.5,0.5
)));
-- Surface with 2 3D polygons (on same plane)
insert into polygons3d values(5,
SDO_Geometry (3003,NULL,NULL ,

```

```
SDO_Elem_Info_Array(1,1006,2,1,1003,1,16,1003,1),
SDO_Ordinate_Array(0.5,0.0,0.0,
0.5,1.0,0.0,
0.0,1.0,0.0,
0.0,0.0,0.0,
0.5,0.0,0.0,
1.5,0.0,0.0,
2.5,1.0,0.0,
1.5,2.0,0.0,
0.5,2.0,0.0,
0.5,0.0,0.0,
1.5,0.0,0.0
));
-- Surface with 2 3D polygons (on two planes)
insert into polygons3d values(5,
SDO_Geometry(3003,NULL,NULL ,
SDO_Elem_Info_Array(1,1006,2,1,1003,3,7,1003,3),
SDO_Ordinate_Array(2,2,2,
4,4,2,
2,2,2,
4,2,4
)));
-- Surface with 2 3D polygons
-- First polygon has one ext and one int.
insert into polygons3d values(6,
SDO_Geometry (3003,NULL,NULL ,
SDO_Elem_Info_Array(1,1006,2,1,1003,1,16,2003,1,31,1003,1),
SDO_Ordinate_Array(0.5,0.0,0.0,
0.5,1.0,0.0,
0.0,1.0,1.0,
0.0,0.0,1.0,
0.5,0.0,0.0,
0.25,0.5,0.5,
0.15,0.5,0.7,
0.15,0.6,0.7,
0.25,0.6,0.5,
0.25,0.5,0.5,
1.5,0.0,0.0,
2.5,1.0,0.0,
1.5,2.0,0.0,
0.5,2.0,0.0,
0.5,0.0,0.0,
1.5,0.0,0.0
)));
--3D Surface with 3 3D polygons
insert into polygons3d values(7,
SDO_Geometry (3003,NULL,NULL ,
SDO_Elem_Info_Array(1,1006,3,1,1003,1,16,1003,1,34,1003,1),
SDO_Ordinate_Array(0.5,0.0,0.0,
0.5,1.0,0.0,
0.0,1.0,1.0,
0.0,0.0,1.0,
0.5,0.0,0.0,
1.5,0.0,0.0,
2.5,1.0,0.0,
1.5,2.0,0.0,
0.5,2.0,0.0,
0.5,0.0,0.0,
1.5,0.0,0.0,
1.5,0.0,0.0,
```

```

2.5,0.0,0.0,
2.5,1.0,0.0,
1.5,0.0,0.0
));
-- 3D surface with 3 3D polygons
insert into polygons3d values(8,
SDO_Geometry (3003,NULL,NULL ,
  SDO_Elem_Info_Array(1,1006,3,1,1003,1,16,2003,1,31,1003,1,49,1003,1) ,
  SDO_Ordinate_Array(0.5,0.0,0.0,
0.5,1.0,0.0,
0.0,1.0,1.0,
0.0,0.0,1.0,
0.5,0.0,0.0,
0.25,0.5,0.5,
0.15,0.5,0.7,
0.15,0.6,0.7,
0.25,0.6,0.5,
0.25,0.5,0.5,
1.5,0.0,0.0,
2.5,1.0,0.0,
1.5,2.0,0.0,
0.5,2.0,0.0,
0.5,0.0,0.0,
1.5,0.0,0.0,
0.5,1.0,0.0,
0.5,2.0,0.0,
0.0,2.0,0.0,
0.0,1.0,0.0,
0.5,1.0,0.0
));
-- Simple 3D polygon
insert into polygons3d values(9,
SDO_Geometry (3003,NULL,NULL ,
  SDO_Elem_Info_Array(1,1003,1),
  SDO_Ordinate_Array(0.0,-4.0,1.0,
4.0,-4.0,1.0,
5.0,-3.0,1.0,
5.0,0.0,1.0,
3.0,1.0,1.0,
-1.0,1.0,1.0,
-3.0,0.5,1.0,
0.0,0.0,1.0,
-6.0,-2.0,1.0,
-6.0,-3.5,1.0,
-2.0,-3.5,1.0,
0.0,-4.0,1.0
));
-- SOLID with 6 polygons
insert into polygons3d values(10,
SDO_Geometry (3008,NULL,NULL ,
  SDO_Elem_Info_
Array(1,1007,1,1,1006,6,1,1003,1,16,1003,1,31,1003,1,46,1003,1,61,1003,1,76,1003,1
),
  SDO_Ordinate_Array(1.0,0.0,-1.0,
1.0,1.0,-1.0,
1.0,1.0,1.0,
1.0,0.0,1.0,
1.0,0.0,-1.0,
1.0,0.0,1.0,
0.0,0.0,1.0,

```

```

0.0,0.0,-1.0,
1.0,0.0,-1.0,
1.0,0.0,1.0,
0.0,1.0,1.0,
0.0,1.0,-1.0,
0.0,0.0,-1.0,
0.0,0.0,1.0,
0.0,1.0,1.0,
1.0,1.0,-1.0,
0.0,1.0,-1.0,
0.0,1.0,1.0,
1.0,1.0,1.0,
1.0,1.0,-1.0,
1.0,1.0,1.0,
0.0,1.0,1.0,
0.0,0.0,1.0,
1.0,0.0,1.0,
1.0,1.0,1.0,
1.0,1.0,-1.0,
1.0,0.0,-1.0,
0.0,0.0,-1.0,
0.0,1.0,-1.0,
1.0,1.0,-1.0
));
-- Simple SOLID with 6 polygons
-- All polygons are described using the optimized rectangle representation.
insert into polygons3d values(11,
SDO_Geometry (3008,NULL,NULL , SDO_Elem_Info_
Array(1,1007,1,1,1006,6,1,1003,3,7,1003,3,13,1003,3,19,1003,3,25,1003,3,31,1003,3)
,
SDO_Ordinate_Array(1.0,0.0,-1.0,
1.0,1.0,1.0,
1.0,0.0,1.0,
0.0,0.0,-1.0,
0.0,1.0,1.0,
0.0,0.0,-1.0,
0.0,1.0,-1.0,
1.0,1.0,1.0,
0.0,0.0,1.0,
1.0,1.0,1.0,
1.0,1.0,-1.0,
0.0,0.0,-1.0
));
-- Multi-Solid
-- Both solids use optimized representation.
insert into polygons3d values(12,
SDO_Geometry (3009,NULL,NULL ,
SDO_Elem_Info_Array(1,1007,3,7,1007,3),
SDO_Ordinate_Array(-2.0,1.0,3.0,
-3.0,-1.0,0.0,
0.0,0.0,0.0,
1.0,1.0,1.0
));
-- Multi-Solid - like multi-polygon in 2D
-- disjoint solids
insert into polygons3d values(13,
SDO_Geometry (3009,NULL,NULL , SDO_Elem_Info_
Array(1,1007,1,1,1006,6,1,1003,1,16,1003,1,31,1003,1,46,1003,1,61,1003,1,76,1003,1
,91,1007,1,91,1006,7,91,1003,1,106,1003,1,121,1003,1,136,1003,1,151,1003,1,166,100
3,1,184,1003,1),

```

```

SDO_Ordinate_Array(1.0,0.0,4.0,
1.0,1.0,4.0,
1.0,1.0,6.0,
1.0,0.0,6.0,
1.0,0.0,4.0,
1.0,0.0,6.0,
0.0,0.0,6.0,
0.0,0.0,4.0,
1.0,0.0,4.0,
1.0,0.0,6.0,
0.0,1.0,6.0,
0.0,1.0,4.0,
0.0,0.0,4.0,
0.0,0.0,6.0,
0.0,1.0,6.0,
1.0,1.0,4.0,
0.0,1.0,4.0,
0.0,1.0,6.0,
1.0,1.0,6.0,
1.0,1.0,4.0,
1.0,1.0,6.0,
0.0,1.0,6.0,
0.0,0.0,6.0,
1.0,0.0,6.0,
1.0,1.0,6.0,
1.0,1.0,4.0,
1.0,0.0,4.0,
0.0,0.0,4.0,
0.0,1.0,4.0,
1.0,1.0,4.0,
2.0,0.0,3.0,
2.0,0.0,0.0,
4.0,2.0,0.0,
4.0,2.0,3.0,
2.0,0.0,3.0,
4.5,-2.0,3.0,
4.5,-2.0,0.0,
2.0,0.0,0.0,
2.0,0.0,3.0,
4.5,-2.0,3.0,
4.5,-2.0,3.0,
-2.0,-2.0,3.0,
-2.0,-2.0,0.0,
4.5,-2.0,0.0,
4.5,-2.0,3.0,
-2.0,-2.0,3.0,
-2.0,2.0,3.0,
-2.0,2.0,0.0,
-2.0,-2.0,0.0,
-2.0,-2.0,3.0,
4.0,2.0,3.0,
4.0,2.0,0.0,
-2.0,2.0,0.0,
-2.0,2.0,3.0,
4.0,2.0,3.0,
2.0,0.0,3.0,
4.0,2.0,3.0,
-2.0,2.0,3.0,
-2.0,-2.0,3.0,
4.5,-2.0,3.0,

```

```

2.0,0.0,3.0,
2.0,0.0,0.0,
4.5,-2.0,0.0,
-2.0,-2.0,0.0,
-2.0,2.0,0.0,
4.0,2.0,0.0,
2.0,0.0,0.0
));

-- SOLID with a hole
-- etype = 1007 exterior solid
-- etype = 2007 is interior solid
-- All polygons of etype=2007 are described as 2003's.
insert into polygons3d values(14,
SDO_Geometry (3008,NULL,NULL ,
  SDO_Elem_Info_
Array(1,1007,1,1,1006,7,1,1003,1,16,1003,1,31,1003,1,46,1003,1,61,1003,1,76,1003,1
,94,1003,1,112,2006,6,112,2003,1,127,2003,1,142,2003,1,157,2003,1,172,2003,1,187,2
003,1),
  SDO_Ordinate_Array(2.0,0.0,3.0,
2.0,0.0,0.0,
4.0,2.0,0.0,
4.0,2.0,3.0,
2.0,0.0,3.0,
4.5,-2.0,3.0,
4.5,-2.0,0.0,
2.0,0.0,0.0,
2.0,0.0,3.0,
4.5,-2.0,3.0,
4.5,-2.0,3.0,
-2.0,-2.0,3.0,
-2.0,-2.0,0.0,
4.5,-2.0,0.0,
4.5,-2.0,3.0,
-2.0,-2.0,3.0,
-2.0,2.0,3.0,
-2.0,2.0,0.0,
-2.0,-2.0,0.0,
-2.0,-2.0,3.0,
4.0,2.0,3.0,
4.0,2.0,0.0,
-2.0,2.0,0.0,
-2.0,2.0,3.0,
4.0,2.0,3.0,
2.0,0.0,3.0,
4.0,2.0,3.0,
-2.0,2.0,3.0,
-2.0,-2.0,3.0,
4.5,-2.0,3.0,
2.0,0.0,3.0,
2.0,0.0,0.0,
4.5,-2.0,0.0,
-2.0,-2.0,0.0,
-2.0,2.0,0.0,
4.0,2.0,0.0,
2.0,0.0,0.0,
1.0,1.0,2.5,
-1.0,1.0,2.5,
-1.0,1.0,0.5,
1.0,1.0,0.5,

```

```

1.0,1.0,2.5,
-1.0,1.0,2.5,
-1.0,-1.0,2.5,
-1.0,-1.0,0.5,
-1.0,1.0,0.5,
-1.0,1.0,2.5,
-1.0,-1.0,2.5,
1.0,-1.0,2.5,
1.0,-1.0,0.5,
-1.0,-1.0,0.5,
-1.0,-1.0,2.5,
1.0,-1.0,2.5,
1.0,1.0,2.5,
1.0,1.0,0.5,
1.0,-1.0,0.5,
1.0,-1.0,2.5,
-1.0,-1.0,2.5,
-1.0,1.0,2.5,
1.0,1.0,2.5,
1.0,-1.0,2.5,
-1.0,-1.0,2.5,
1.0,1.0,0.5,
-1.0,1.0,0.5,
-1.0,-1.0,0.5,
1.0,-1.0,0.5,
1.0,1.0,0.5
)))
-- Gtype = SOLID
-- The elements make up one composite solid (non-disjoint solids) like a cube
-- on a cube on a cube.
-- This is made up of two solid elements.
-- Each solid element here is a simple solid.
insert into polygons3d values(15,
SDO_Geometry (3008,NULL,NULL ,
SDO_Elem_Info_
Array(1,1008,2,1,1007,1,1,1006,6,1,1003,1,16,1003,1,31,1003,1,46,1003,1,61,1003,1,
76,1003,1,91,1007,1,91,1006,7,91,1003,1,106,1003,1,121,1003,1,136,1003,1,151,1003,
1,166,1003,1,184,1003,1),
SDO_Ordinate_Array(-2.0,1.0,3.0,
-2.0,1.0,0.0,
-3.0,1.0,0.0,
-3.0,1.0,3.0,
-2.0,1.0,3.0,
-3.0,1.0,3.0,
-3.0,1.0,0.0,
-3.0,-1.0,0.0,
-3.0,-1.0,3.0,
-3.0,1.0,3.0,
-3.0,-1.0,3.0,
-3.0,-1.0,0.0,
-2.0,-1.0,0.0,
-2.0,-1.0,3.0,
-3.0,-1.0,3.0,
-2.0,-1.0,3.0,
-2.0,-1.0,0.0,
-2.0,1.0,0.0,
-2.0,1.0,3.0,
-2.0,-1.0,3.0,
-2.0,-1.0,3.0,
-2.0,1.0,3.0,

```



```

-3.0,1.0,3.0,
-3.0,-1.0,3.0,
-2.0,-1.0,3.0,
-2.0,1.0,0.0,
-2.0,-1.0,0.0,
-3.0,-1.0,0.0,
-3.0,1.0,0.0,
-2.0,1.0,0.0,
2.0,0.0,3.0,
2.0,0.0,0.0,
4.0,2.0,0.0,
4.0,2.0,3.0,
2.0,0.0,3.0,
4.5,-2.0,3.0,
4.5,-2.0,0.0,
2.0,0.0,0.0,
2.0,0.0,3.0,
4.5,-2.0,3.0,
4.5,-2.0,3.0,
-2.0,-2.0,3.0,
-2.0,-2.0,0.0,
4.5,-2.0,0.0,
4.5,-2.0,3.0,
-2.0,-2.0,3.0,
-2.0,2.0,3.0,
-2.0,2.0,0.0,
-2.0,-2.0,0.0,
-2.0,-2.0,3.0,
4.0,2.0,3.0,
4.0,2.0,0.0,
-2.0,2.0,0.0,
-2.0,2.0,3.0,
4.0,2.0,3.0,
2.0,0.0,3.0,
4.0,2.0,3.0,
-2.0,2.0,3.0,
-2.0,-2.0,3.0,
4.5,-2.0,3.0,
2.0,0.0,3.0,
2.0,0.0,0.0,
4.5,-2.0,0.0,
-2.0,-2.0,0.0,
-2.0,2.0,0.0,
4.0,2.0,0.0,
2.0,0.0,0.0
)))

```

Example 2–17 updates the USER_SDO_GEOM_METADATA view with the necessary information about the tables created in **Example 2–16** (POINTS3D, LINES3D, and POLYGONS3D), and it creates a spatial index on the geometry column (named GEOMETRY) in each table. The indexes are created with the PARAMETERS ('sdo_indx_dims=3') clause, to ensure that all three dimensions are considered in operations that are supported on three-dimensional geometries.

Example 2–17 Updating Metadata and Creating Indexes for 3-Dimensional Geometries

```

INSERT INTO user_sdo_geom_metadata VALUES('POINTS3D', 'GEOMETRY',
sdo_dim_array( sdo_dim_element('X', -100,100, 0.000005),
sdo_dim_element('Y', -100,100, 0.000005),
sdo_dim_element('Z', -100,100, 0.000005)), NULL);

```

```

CREATE INDEX points3d_sidx on points3d(geometry)
  INDEXTYPE IS mdsys.spatial_index
  PARAMETERS ('sdo_indx_dims=3');

INSERT INTO user_sdo_geom_metadata VALUES('LINES3D', 'GEOMETRY',
  sdo_dim_array( sdo_dim_element('X', -100,100, 0.000005),
  sdo_dim_element('Y', -100,100, 0.000005),
  sdo_dim_element('Z', -100,100, 0.000005)), NULL);

CREATE INDEX lines3d_sidx on lines3d(geometry)
  INDEXTYPE IS mdsys.spatial_index
  PARAMETERS ('sdo_indx_dims=3');

INSERT INTO user_sdo_geom_metadata VALUES('POLYGONS3D', 'GEOMETRY',
  sdo_dim_array( sdo_dim_element('X', -100,100, 0.000005),
  sdo_dim_element('Y', -100,100, 0.000005),
  sdo_dim_element('Z', -100,100, 0.000005)), NULL);

CREATE INDEX polygons3d_sidx on polygons3d(geometry)
  INDEXTYPE IS mdsys.spatial_index
  PARAMETERS ('sdo_indx_dims=3');

```

2.8 Geometry Metadata Views

The geometry metadata describing the dimensions, lower and upper bounds, and tolerance in each dimension is stored in a global table owned by MDSYS (which users should never directly update). Each Spatial user has the following views available in the schema associated with that user:

- **USER_SDO_GEOM_METADATA** contains metadata information for all spatial tables owned by the user (schema). This is the only view that you can update, and it is the one in which Spatial users must insert metadata related to spatial tables.
- **ALL_SDO_GEOM_METADATA** contains metadata information for all spatial tables on which the user has SELECT permission.

Spatial users are responsible for populating these views. For each spatial column, you must insert an appropriate row into the **USER_SDO_GEOM_METADATA** view. Oracle Spatial ensures that the **ALL_SDO_GEOM_METADATA** view is also updated to reflect the rows that you insert into **USER_SDO_GEOM_METADATA**.

Each metadata view has the following definition:

```

(
  TABLE_NAME  VARCHAR2(32),
  COLUMN_NAME  VARCHAR2(32),
  DIMINFO      SDO_DIM_ARRAY,
  SRID         NUMBER
);

```

In addition, the **ALL_SDO_GEOM_METADATA** view has an **OWNER** column identifying the schema that owns the table specified in **TABLE_NAME**.

The following considerations apply to schema, table, and column names, and to any **SDO_DIMNAME** values, that are stored in any Oracle Spatial metadata views:

- They must contain only letters, numbers, and underscores. For example, such a name cannot contain a space (), an apostrophe ('), a quotation mark ("), or a comma (,).

- All letters in the names are converted to uppercase before the names are stored in geometry metadata views or before the tables are accessed. This conversion also applies to any schema name specified with the table name.

2.8.1 TABLE_NAME

The TABLE_NAME column contains the name of a feature table, such as COLA_MARKETS, that has a column of type SDO_GEOMETRY.

The table name is stored in the spatial metadata views in all uppercase characters.

The table name cannot contain spaces or mixed-case letters in a quoted string when inserted into the USER_SDO_GEOM_METADATA view, and it cannot be in a quoted string when used in a query (unless it is in all uppercase characters).

The spatial feature table cannot be an index-organized table if you plan to create a spatial index on the spatial column.

2.8.2 COLUMN_NAME

The COLUMN_NAME column contains the name of the column of type SDO_GEOMETRY. For the COLA_MARKETS table, this column is called SHAPE.

The column name is stored in the spatial metadata views in all uppercase characters.

The column name cannot contain spaces or mixed-case letters in a quoted string when inserted into the USER_SDO_GEOM_METADATA view, and it cannot be in a quoted string when used in a query (unless it is in all uppercase characters).

2.8.3 DIMINFO

The DIMINFO column is a varying length array of an object type, ordered by dimension, and has one entry for each dimension. The SDO_DIM_ARRAY type is defined as follows:

```
Create Type SDO_DIM_ARRAY as VARRAY(4) of SDO_DIM_ELEMENT;
```

The SDO_DIM_ELEMENT type is defined as:

```
Create Type SDO_DIM_ELEMENT as OBJECT (
  SDO_DIMNAME VARCHAR2(64),
  SDO_LB NUMBER,
  SDO_UB NUMBER,
  SDO_TOLERANCE NUMBER);
```

The SDO_DIM_ARRAY instance is of size n if there are n dimensions. That is, DIMINFO contains 2 SDO_DIM_ELEMENT instances for two-dimensional geometries, 3 instances for three-dimensional geometries, and 4 instances for four-dimensional geometries. Each SDO_DIM_ELEMENT instance in the array must have valid (not null) values for the SDO_LB, SDO_UB, and SDO_TOLERANCE attributes.

Note: The number of dimensions reflected in the DIMINFO information must match the number of dimensions of each geometry object in the layer.

For an explanation of tolerance and how to determine the appropriate SDO_TOLERANCE value, see [Section 1.5.5](#), especially [Section 1.5.5.1](#).

Spatial assumes that the varying length array is ordered by dimension. The DIMINFO varying length array must be ordered by dimension in the same way the ordinates for the points in SDO_ORDINATES varying length array are ordered. For example, if the SDO_ORDINATES varying length array contains {X1, Y1, ..., Xn, Yn}, then the first DIMINFO entry must define the X dimension and the second DIMINFO entry must define the Y dimension.

[Example 2-1](#) in [Section 2.1](#) shows the use of the SDO_GEOMETRY and SDO_DIM_ARRAY types. This example demonstrates how geometry objects (hypothetical market areas for colas) are represented, and how the COLA_MARKETS feature table and the USER_SDO_GEOM_METADATA view are populated with the data for those objects.

2.8.4 SRID

The SRID column should contain either of the following: the SRID value for the coordinate system for all geometries in the column, or NULL if no specific coordinate system should be associated with the geometries. (For information about coordinate systems, see [Chapter 6](#).)

2.9 Spatial Index-Related Structures

This section describes the structure of the tables containing the spatial index data and metadata. Concepts and usage notes for spatial indexing are explained in [Section 1.7](#). The spatial index data and metadata are stored in tables that are created and maintained by the Spatial indexing routines. These tables are created in the schema of the owner of the feature (underlying) table that has a spatial index created on a column of type SDO_GEOMETRY.

2.9.1 Spatial Index Views

There are two sets of spatial index metadata views for each schema (user): `xxx_SDO_INDEX_INFO` and `xxx_SDO_INDEX_METADATA`, where `xxx` can be USER or ALL. These views are read-only to users; they are created and maintained by the Spatial indexing routines.

2.9.1.1 xxx_SDO_INDEX_INFO Views

The following views contain basic information about spatial indexes:

- `USER_SDO_INDEX_INFO` contains index information for all spatial tables owned by the user.
- `ALL_SDO_INDEX_INFO` contains index information for all spatial tables on which the user has SELECT permission.

The `USER_SDO_INDEX_INFO` and `ALL_SDO_INDEX_INFO` views contain the same columns, as shown [Table 2-8](#), except that the `USER_SDO_INDEX_INFO` view does not contain the `SDO_INDEX_OWNER` column. (The columns are listed in their order in the view definition.)

Table 2-8 Columns in the xxx_SDO_INDEX_INFO Views

Column Name	Data Type	Purpose
SDO_INDEX_OWNER	VARCHAR2	Owner of the index (ALL_SDO_INDEX_INFO view only).
INDEX_NAME	VARCHAR2	Name of the index.

Table 2–8 (Cont.) Columns in the xxx_SDO_INDEX_INFO Views

Column Name	Data Type	Purpose
TABLE_OWNER	VARCHAR2	Name of the owner of the table containing the column on which this index is built.
TABLE_NAME	VARCHAR2	Name of the table containing the column on which this index is built.
COLUMN_NAME	VARCHAR2	Name of the column on which this index is built.
SDO_INDEX_TYPE	VARCHAR2	Contains RTREE (for an R-tree index).
SDO_INDEX_TABLE	VARCHAR2	Name of the spatial index table (described in Section 2.9.2).
SDO_INDEX_STATUS	VARCHAR2	(Reserved for Oracle use.)

2.9.1.2 xxx_SDO_INDEX_METADATA Views

The following views contain detailed information about spatial index metadata:

- USER_SDO_INDEX_METADATA contains index information for all spatial tables owned by the user.
- ALL_SDO_INDEX_METADATA contains index information for all spatial tables on which the user has SELECT permission.

The USER_SDO_INDEX_METADATA and ALL_SDO_INDEX_METADATA views contain the same columns, as shown [Table 2–9](#). (The columns are listed in their order in the view definition.)

Table 2–9 Columns in the xxx_SDO_INDEX_METADATA Views

Column Name	Data Type	Purpose
SDO_INDEX_OWNER	VARCHAR2	Owner of the index.
SDO_INDEX_TYPE	VARCHAR2	Contains RTREE (for an R-tree index).
SDO_LEVEL	NUMBER	(No longer relevant; applies to a de-supported feature.)
SDO_NUMTILES	NUMBER	(No longer relevant; applies to a de-supported feature.)
SDO_MAXLEVEL	NUMBER	(No longer relevant; applies to a de-supported feature.)
SDO_COMMIT_INTERVAL	NUMBER	(No longer relevant; applies to a de-supported feature.)
SDO_INDEX_TABLE	VARCHAR2	Name of the spatial index table (described in Section 2.9.2).
SDO_INDEX_NAME	VARCHAR2	Name of the index.
SDO_INDEX_PRIMARY	NUMBER	Indicates if this is a primary or secondary index. 1 = primary, 2 = secondary.
SDO_TSNAME	VARCHAR2	Schema name of the SDO_INDEX_TABLE.
SDO_COLUMN_NAME	VARCHAR2	Name of the column on which this index is built.
SDO_RTREE_HEIGHT	NUMBER	Height of the R-tree.
SDO_RTREE_NUM_NODES	NUMBER	Number of nodes in the R-tree.

Table 2–9 (Cont.) Columns in the xxx_SDO_INDEX_METADATA Views

Column Name	Data Type	Purpose
SDO_RTREE_DIMENSIONALITY	NUMBER	Number of dimensions used internally by Spatial. This may be different from the number of dimensions indexed, which is controlled by the <code>sdo_indx_dims</code> keyword in the CREATE INDEX or ALTER INDEX statement, and which is stored in the <code>SDO_INDEX_DIMS</code> column in this view. For example, for an index on geodetic data, the <code>SDO_RTREE_DIMENSIONALITY</code> value is 3, but the <code>SDO_INDEX_DIMS</code> value is 2.
SDO_RTREE_FANOUT	NUMBER	Maximum number of children in each R-tree node.
SDO_RTREE_ROOT	VARCHAR2	Rowid corresponding to the root node of the R-tree in the index table.
SDO_RTREE_SEQ_NAME	VARCHAR2	Sequence name associated with the R-tree.
SDO_FIXED_META	RAW	If applicable, this column contains the metadata portion of the <code>SDO_GROUPCODE</code> or <code>SDO_CODE</code> for a fixed-level index.
SDO_TABLESPACE	VARCHAR2	Same as in the SQL <code>CREATE TABLE</code> statement. Tablespace in which to create the <code>SDOINDEX</code> table.
SDO_INITIAL_EXTENT	VARCHAR2	Same as in the SQL <code>CREATE TABLE</code> statement.
SDO_NEXT_EXTENT	VARCHAR2	Same as in the SQL <code>CREATE TABLE</code> statement.
SDO_PCTINCREASE	NUMBER	Same as in the SQL <code>CREATE TABLE</code> statement.
SDO_MIN_EXTENTS	NUMBER	Same as in the SQL <code>CREATE TABLE</code> statement.
SDO_MAX_EXTENTS	NUMBER	Same as in the SQL <code>CREATE TABLE</code> statement.
SDO_INDEX_DIMS	NUMBER	Number of dimensions of the geometry objects in the column on which this index is built, as determined by the value of the <code>sdo_indx_dims</code> keyword in the CREATE INDEX or ALTER INDEX statement.
SDO_LAYER_GTYPE	VARCHAR2	Contains <code>DEFAULT</code> if the layer can contain both point and polygon data, or a value from the <code>Geometry Type</code> column of Table 2–1 in Section 2.2.1 .
SDO_RTREE_PCTFREE	NUMBER	Minimum percentage of slots in each index tree node to be left empty when an R-tree index is created.
SDO_INDEX_PARTITION	VARCHAR2	For a partitioned index, name of the index partition.
SDO_PARTITIONED	NUMBER	Contains 0 if the index is not partitioned or 1 if the index is partitioned.
SDO_RTREE_QUALITY	NUMBER	Quality score for an index. See the information about R-tree quality in Section 1.7.2 .
SDO_INDEX_VERSION	NUMBER	Internal version number of the index.
SDO_INDEX_GEODETTIC	VARCHAR2	Contains <code>TRUE</code> if the index is geodetic and <code>FALSE</code> if the index is not geodetic.
SDO_INDEX_STATUS	VARCHAR2	(Reserved for Oracle use.)

Table 2–9 (Cont.) Columns in the xxx_SDO_INDEX_METADATA Views

Column Name	Data Type	Purpose
SDO_NL_INDEX_TABLE	VARCHAR2	Name of a separate index table (with a name in the form MDNT_...\$) for nonleaf nodes of the index. For more information, see the description of the <code>sdo_non_leaf_tbl</code> parameter for the CREATE INDEX statement in Chapter 18 .
SDO_DML_BATCH_SIZE	NUMBER	Number of index updates to be processed in each batch of updates after a commit operation. For more information, see the description of the <code>sdo_dml_batch_size</code> parameter for the CREATE INDEX statement in Chapter 18 .
SDO_RTREE_EXT_XPND	NUMBER	(Reserved for future use.)
SDO_ROOT_MBR	SDO_GEOMETRY	Minimum bounding rectangle of the maximum extent of the spatial layer. This is greater than or equal to the MBR of the current extent, and is reset to reflect the current extent when the index is rebuilt.

2.9.2 Spatial Index Table Definition

For an R-tree index, a spatial index table (each SDO_INDEX_TABLE entry as described in [Table 2–9](#) in [Section 2.9.1.2](#)) contains the columns shown in [Table 2–10](#).

Table 2–10 Columns in an R-Tree Spatial Index Data Table

Column Name	Data Type	Purpose
NODE_ID	NUMBER	Unique ID number for this node of the tree.
NODE_LEVEL	NUMBER	Level of the node in the tree. Leaf nodes (nodes whose entries point to data items in the base table) are at level 1, their parent nodes are at level 2, and so on.
INFO	BLOB	Other information in a node. Includes an array of <code><child_mbr, child_rowid></code> pairs (maximum of fanout value, or number of children for such pairs in each R-tree node), where <code>child_rowid</code> is the rowid of a child node, or the rowid of a data item from the base table.

2.9.3 R-Tree Index Sequence Object

Each R-tree spatial index table has an associated sequence object (SDO_RTREE_SEQ_NAME in the USER_SDO_INDEX_METADATA view, described in [Table 2–9](#) in [Section 2.9.1.2](#)). The sequence is used to ensure that simultaneous updates can be performed to the index by multiple concurrent users.

The sequence name is the index table name with the letter *S* replacing the letter *T* before the underscore (for example, the sequence object MDRS_5C01\$ is associated with the index table MDRT_5C01\$).

2.10 Unit of Measurement Support

Geometry functions that involve measurement allow an optional `unit` parameter to specify the unit of measurement for a specified distance or area, if a georeferenced coordinate system (SDO_SRID value) is associated with the input geometry or geometries. The `unit` parameter is not valid for geometries with a null SDO_SRID value (that is, an orthogonal Cartesian system). For information about support for coordinate systems, see [Chapter 6](#).

The default unit of measure is the one associated with the georeferenced coordinate system. The unit of measure for most coordinate systems is the meter, and in these cases the default unit for distances is meter and the default unit for areas is square meter. By using the `unit` parameter, however, you can have Spatial automatically convert and return results that are more meaningful to application users, for example, displaying the distance to a restaurant in miles.

The `unit` parameter must be enclosed in single quotation marks and contain the string `unit=` and a valid `UNIT_OF_MEAS_NAME` value from the `SDO_UNITS_OF_MEASURE` table (described in [Section 6.7.27](#)). For example, `'unit=KM'` in the following example (using data and definitions from [Example 6–17](#) in [Section 6.13](#)) specifies kilometers as the unit of measurement:

```
SELECT c.name, SDO_GEOM.SDO_LENGTH(c.shape, m.diminfo, 'unit=KM')
   FROM cola_markets_cs c, user_sdo_geom_metadata m
   WHERE m.table_name = 'COLA_MARKETS_CS' AND m.column_name = 'SHAPE';
```

Spatial uses the information in the `SDO_UNITS_OF_MEASURE` table (described in [Section 6.7.27](#)) to determine which unit names are valid and what ratios to use in comparing or converting between different units. For convenience, you can also use the following legacy views to see the angle, area, and distance units of measure:

- `MDSYS.SDO_ANGLE_UNITS` (described in [Section 6.8.2](#))
- `MDSYS.SSDO_AREA_UNITS` (described in [Section 6.8.3](#))
- `MDSYS.SSDO_DIST_UNITS` (described in [Section 6.8.5](#))

2.10.1 Creating a User-Defined Unit of Measurement

If the area and distance units of measurement supplied by Oracle are not sufficient for your needs, you can create user-defined area and distance units. (You cannot create a user-defined angle unit.) To do so, you must connect to the database as a user that has been granted the `DBA` role, and insert a row for each desired unit to the `SDO_UNITS_OF_MEASURE` table (described in [Section 6.7.27](#))

[Table 2–11](#) lists the columns in the `SDO_UNITS_OF_MEASURE` table and the requirements and recommendations for each if you are inserting a row for a user-defined unit of measurement.

Table 2–11 *SDO_UNITS_OF_MEASURE Table Entries for User-Defined Unit*

Column Name	Description
<code>UOM_ID</code>	Any unit of measure ID number not currently used for an Oracle-supplied unit or another user-defined unit. Example: 1000001
<code>UNIT_OF_MEAS_NAME</code>	Name of the user-defined unit of measurement. Example: <code>HALF_METER</code>
<code>SHORT_NAME</code>	Optional short name (if any) of the unit of measurement.
<code>UNIT_OF_MEAS_TYPE</code>	Type of measure for which the unit is used. Must be either <code>area</code> (for an area unit) or <code>length</code> (for a distance unit).
<code>TARGET_UOM_ID</code>	Optional, but for support purposes you should enter one of the following: 10008 for an area unit (10008 = <code>UOM_ID</code> for <code>SQ_METER</code>) or 10032 for a distance unit (10032 = <code>UOM_ID</code> for <code>METER</code>).

Table 2–11 (Cont.) SDO_UNITS_OF_MEASURE Table Entries for User-Defined Unit

Column Name	Description
FACTOR_B	For a value that can be expressed as a floating point number, specify how many square meters (for an area unit) or meters (for a distance unit) are equal to one of the user-defined unit. For example, for a unit defined as one-half of a standard meter, specify: .5 For a value that cannot be expressed as a simple floating point number, specify the dividend for the expression FACTOR_B/FACTOR_C that determines how many square meters (for an area unit) or meters (for a distance unit) are equal to one of the user-defined unit.
FACTOR_C	For a value that can be expressed as a floating point number, specify 1. For a value that cannot be expressed as a simple floating point number, specify the divisor for the expression FACTOR_B/FACTOR_C that determines how many square meters (for an area unit) or meters (for a distance unit) are equal to one of the user-defined unit.
INFORMATION_SOURCE	Specify the following: USER_DEFINED
DATA_SOURCE	A phrase briefly describing the unit. Example: User-defined half meter
IS_LEGACY	Specify the following: FALSE.
LEGACY_CODE	(Do not use this for a user-defined unit.)

[Example 2–18](#) creates a user-defined distance unit named HALF_METER, and uses it in a query to find all customers within 400,000 half-meters (200 kilometers) of a specified store.

Example 2–18 Creating and Using a User-Defined Unit of Measurement

```
-- Distance unit: HALF_METER
-- FACTOR_B specifies how many meters = one of this unit.

INSERT INTO MDSYS.SDO_UNITS_OF_MEASURE
  (UOM_ID, UNIT_OF_MEAS_NAME, UNIT_OF_MEAS_TYPE, TARGET_UOM_ID,
   FACTOR_B, FACTOR_C, INFORMATION_SOURCE, DATA_SOURCE, IS_LEGACY)
VALUES
  (100001, 'HALF_METER', 'length', 100001,
   .5, 1, 'User-defined half meter', 'USER_DEFINED', 'FALSE');

. . .
-- Find all the customers within 400,000 half-meters of store_id = 101
SELECT /*+ordered*/
  c.customer_id,
  c.first_name,
  c.last_name
FROM stores s,
  customers c
WHERE s.store_id = 101
AND sdo_within_distance (c.cust_geo_location,
  s.store_geo_location,
  'distance = 400000 unit = HALF_METER') = 'TRUE';

CUSTOMER_ID FIRST_NAME LAST_NAME
-----
1005 Carla Rodriguez
1004 Thomas Williams
1003 Marian Chang
```

1001 Alexandra

Nichols

SQL Multimedia Type Support

This chapter explains the support within Oracle Spatial for the use of the *ST_xxx* types specified in *ISO 13249-3, Information technology - Database languages - SQL Multimedia and Application Packages - Part 3: Spatial*. This chapter contains the following major sections:

- [Section 3.1, "ST_GEOMETRY and SDO_GEOMETRY Interoperability"](#)
- [Section 3.3, "Tolerance Value with SQL Multimedia Types"](#)
- [Section 3.4, "Avoiding Name Conflicts"](#)
- [Section 3.5, "Annotation Text Type and Views"](#)

3.1 ST_GEOMETRY and SDO_GEOMETRY Interoperability

The SQL Multimedia *ST_GEOMETRY* root type, including its subtypes, and the Oracle Spatial *SDO_GEOMETRY* type (described in [Section 2.2](#)) are essentially interoperable. The *ST_GEOMETRY* subtypes are:

- *ST_CIRCULARSTRING*
- *ST_COMPOUNDCURVE*
- *ST_CURVE*
- *ST_CURVEPOLYGON*
- *ST_GEOMCOLLECTION*
- *ST_LINestring*
- *ST_MULTICURVE*
- *ST_MULTILINestring*
- *ST_MULTIPPOINT*
- *ST_MULTIPOLYGON*
- *ST_MULTISURFACE*
- *ST_POINT*
- *ST_POLYGON*
- *ST_SURFACE*

The *ST_GEOMETRY* type has an additional constructor method (that is, in addition to the constructors defined in the ISO standard) for creating an instance of the type using an *SDO_GEOMETRY* object. This constructor has the following format:

```
ST_GEOMETRY(geom SDO_GEOMETRY);
```

[Example 3–1](#) creates a table using the ST_GEOMETRY type for a spatial column instead of the SDO_GEOMETRY type, and it uses the ST_GEOMETRY constructor to specify the SHAPE column value when inserting a row into that table.

Example 3–1 Using the ST_GEOMETRY Type for a Spatial Column

```
CREATE TABLE cola_markets (
  mkt_id NUMBER PRIMARY KEY,
  name VARCHAR2(32),
  shape ST_GEOMETRY);

INSERT INTO cola_markets VALUES(
  1,
  'cola_a',
  ST_GEOMETRY(
    SDO_GEOMETRY(
      2003, -- two-dimensional polygon
      NULL,
      NULL,
      SDO_ELEM_INFO_ARRAY(1,1003,3), -- one rectangle (1003 = exterior)
      SDO_ORDINATE_ARRAY(1,1, 5,7) -- only 2 points needed to
        -- define rectangle (lower left and upper right) with
        -- Cartesian-coordinate data
    )
  )
);
```

If you create a table with a spatial column of type ST_GEOMETRY, you should add its information to the USER_SDO_GEOM_METADATA view and create a spatial index on the ST_GEOMETRY column, just as you would for spatial data defined using the SDO_GEOMETRY type. After you have performed these operations, you can use Oracle Spatial operators (described in [Chapter 19](#)) in the ST_GEOMETRY data. In addition to the operators defined in the standard, you can use the [SDO_NN](#) and [SDO_WITHIN_DISTANCE](#) operators.

[Example 3–2](#) performs many of the same basic operations as in [Example 2–1](#) in [Section 2.1](#), but it uses the ST_GEOMETRY type instead of the SDO_GEOMETRY type for the spatial column.

Example 3–2 Creating, Indexing, Storing, and Querying ST_GEOMETRY Data

```
CREATE TABLE cola_markets (
  mkt_id NUMBER PRIMARY KEY,
  name VARCHAR2(32),
  shape ST_GEOMETRY);

INSERT INTO cola_markets VALUES(
  1,
  'cola_a',
  ST_GEOMETRY(
    SDO_GEOMETRY(
      2003, -- two-dimensional polygon
      NULL,
      NULL,
      SDO_ELEM_INFO_ARRAY(1,1003,3), -- one rectangle (1003 = exterior)
      SDO_ORDINATE_ARRAY(1,1, 5,7) -- only 2 points needed to
        -- define rectangle (lower left and upper right) with
        -- Cartesian-coordinate data
    )
  )
);
```

```

    )
  )
);

INSERT INTO cola_markets VALUES(
  2,
  'cola_b',
  ST_GEOMETRY(
    SDO_GEOMETRY(
      2003, -- two-dimensional polygon
      NULL,
      NULL,
      SDO_ELEM_INFO_ARRAY(1,1003,1), -- one polygon (exterior polygon ring)
      SDO_ORDINATE_ARRAY(5,1, 8,1, 8,6, 5,7, 5,1)
    )
  )
);

INSERT INTO cola_markets VALUES(
  3,
  'cola_c',
  ST_GEOMETRY(
    SDO_GEOMETRY(
      2003, -- two-dimensional polygon
      NULL,
      NULL,
      SDO_ELEM_INFO_ARRAY(1,1003,1), -- one polygon (exterior polygon ring)
      SDO_ORDINATE_ARRAY(3,3, 6,3, 6,5, 4,5, 3,3)
    )
  )
);

INSERT INTO cola_markets VALUES(
  4,
  'cola_d',
  ST_GEOMETRY(
    SDO_GEOMETRY(
      2003, -- two-dimensional polygon
      NULL,
      NULL,
      SDO_ELEM_INFO_ARRAY(1,1003,4), -- one circle
      SDO_ORDINATE_ARRAY(8,7, 10,9, 8,11)
    )
  )
);

-----
-- UPDATE METADATA VIEW --
-----

-- Update the USER_SDO_GEOM_METADATA view. This is required before
-- the spatial index can be created. Do this only once for each layer
-- (that is, table-column combination; here: cola_markets and shape).

INSERT INTO user_sdo_geom_metadata
  (TABLE_NAME,
   COLUMN_NAME,
   DIMINFO,
   SRID)
VALUES (

```

```

        'cola_markets',
        'shape',
        SDO_DIM_ARRAY( -- 20X20 grid
            SDO_DIM_ELEMENT('X', 0, 20, 0.005),
            SDO_DIM_ELEMENT('Y', 0, 20, 0.005)
        ),
        NULL -- SRID
    );

-----
-- CREATE THE SPATIAL INDEX --
-----

CREATE INDEX cola_spatial_idx
ON cola_markets(shape)
INDEXTYPE IS MDSYS.SPATIAL_INDEX;

-----
-- SDO_NN and SDO_WITHIN_DISTANCE
-----

-- SDO_NN operator.

SELECT /*+ INDEX(c cola_spatial_idx) */ c.mkt_id, c.name
FROM cola_markets c
WHERE SDO_NN(c.shape, sdo_geometry(2001, NULL,
    sdo_point_type(10,7,NULL), NULL, NULL), 'sdo_num_res=2') = 'TRUE';

-- SDO_NN_DISTANCE ancillary operator

SELECT /*+ INDEX(c cola_spatial_idx) */
c.mkt_id, c.name, SDO_NN_DISTANCE(1) dist
FROM cola_markets c
WHERE SDO_NN(c.shape, sdo_geometry(2001, NULL,
    sdo_point_type(10,7,NULL), NULL, NULL),
    'sdo_num_res=2', 1) = 'TRUE' ORDER BY dist;

-- SDO_WITHIN_DISTANCE operator (two examples)

SELECT c.name FROM cola_markets c WHERE SDO_WITHIN_DISTANCE(c.shape,
    SDO_GEOMETRY(2003, NULL, NULL, SDO_ELEM_INFO_ARRAY(1,1003,3),
    SDO_ORDINATE_ARRAY(4,6, 8,8)),
    'distance=10') = 'TRUE';

-- What geometries are within a distance of 10 from a query window
-- (here, a rectangle with lower-left, upper-right coordinates 4,6, 8,8)?
-- But exclude geoms with MBRs with both sides < 4.1, i.e., cola_c and cola_d.

SELECT c.name FROM cola_markets c WHERE SDO_WITHIN_DISTANCE(c.shape,
    SDO_GEOMETRY(2003, NULL, NULL, SDO_ELEM_INFO_ARRAY(1,1003,3),
    SDO_ORDINATE_ARRAY(4,6, 8,8)),
    'distance=10 min_resolution=4.1') = 'TRUE';

-----
-- Some ST_GEOMETRY member functions
-----

SELECT c.shape.GET_WKB()
FROM cola_markets c WHERE c.name = 'cola_b';

```

```
SELECT c.shape.GET_WKT()
  FROM cola_markets c WHERE c.name = 'cola_b';

SELECT c.shape.ST_COORDDIM()
  FROM cola_markets c WHERE c.name = 'cola_b';

SELECT c.shape.ST_ISVALID()
  FROM cola_markets c WHERE c.name = 'cola_b';

SELECT c.shape.ST_SRID()
  FROM cola_markets c WHERE c.name = 'cola_b';

SELECT c.shape.ST_SRID(8307)
  FROM cola_markets c WHERE c.name = 'cola_b';

SELECT c.shape.ST_ISEMPTY()
  FROM cola_markets c WHERE c.name = 'cola_b';

SELECT c.shape.ST_ENVELOPE()
  FROM cola_markets c WHERE c.name = 'cola_b';

SELECT c.shape.ST_BOUNDARY()
  FROM cola_markets c WHERE c.name = 'cola_b';

SELECT c.shape.ST_GEOMETRYTYPE()
  FROM cola_markets c WHERE c.name = 'cola_b';

SELECT c.shape.ST_ISSIMPLE()
  FROM cola_markets c WHERE c.name = 'cola_b';

SELECT c.shape.ST_DIMENSION()
  FROM cola_markets c WHERE c.name = 'cola_b';

SELECT c.shape.ST_CONVEXHULL()
  FROM cola_markets c WHERE c.name = 'cola_b';

SELECT c.shape.ST_CENTROID()
  FROM cola_markets c WHERE c.name = 'cola_b';

SELECT c.shape.ST_GETTOLERANCE()
  FROM cola_markets c WHERE c.name = 'cola_b';

-- Some member functions that require a parameter
DECLARE
  cola_a_geom ST_GEOMETRY;
  cola_b_geom ST_GEOMETRY;
  cola_c_geom ST_GEOMETRY;
  cola_d_geom ST_GEOMETRY;
  returned_geom ST_GEOMETRY;
  returned_number NUMBER;

BEGIN

-- Populate geometry variables with cola market shapes.
SELECT c.shape INTO cola_a_geom FROM cola_markets c
  WHERE c.name = 'cola_a';
SELECT c.shape INTO cola_b_geom FROM cola_markets c
  WHERE c.name = 'cola_b';
SELECT c.shape INTO cola_c_geom FROM cola_markets c
  WHERE c.name = 'cola_c';
```

```
SELECT c.shape INTO cola_d_geom FROM cola_markets c
WHERE c.name = 'cola_d';

SELECT c.shape.ST_EQUALS(cola_a_geom) INTO returned_number
FROM cola_markets c WHERE c.name = 'cola_b';
DBMS_OUTPUT.PUT_LINE('Is cola_b equal to cola_a?: ' || returned_number);

SELECT c.shape.ST_SYMMETRICDIFFERENCE(cola_a_geom) INTO returned_geom
FROM cola_markets c WHERE c.name = 'cola_b';

SELECT c.shape.ST_DISTANCE(cola_d_geom) INTO returned_number
FROM cola_markets c WHERE c.name = 'cola_b';
DBMS_OUTPUT.PUT_LINE('Distance between cola_b equal to cola_d: ' || returned_
number);

SELECT c.shape.ST_INTERSECTS(cola_a_geom) INTO returned_number
FROM cola_markets c WHERE c.name = 'cola_b';
DBMS_OUTPUT.PUT_LINE('Does cola_b intersect cola_a?: ' || returned_number);

SELECT c.shape.ST_CROSS(cola_a_geom) INTO returned_number
FROM cola_markets c WHERE c.name = 'cola_b';
DBMS_OUTPUT.PUT_LINE('Does cola_b cross cola_a?: ' || returned_number);

SELECT c.shape.ST_DISJOINT(cola_a_geom) INTO returned_number
FROM cola_markets c WHERE c.name = 'cola_b';
DBMS_OUTPUT.PUT_LINE('Is cola_b disjoint with cola_a?: ' || returned_number);

SELECT c.shape.ST_TOUCH(cola_a_geom) INTO returned_number
FROM cola_markets c WHERE c.name = 'cola_b';
DBMS_OUTPUT.PUT_LINE('Does cola_b touch cola_a?: ' || returned_number);

SELECT c.shape.ST_WITHIN(cola_a_geom) INTO returned_number
FROM cola_markets c WHERE c.name = 'cola_b';
DBMS_OUTPUT.PUT_LINE('Is cola_b within cola_a?: ' || returned_number);

SELECT c.shape.ST_OVERLAP(cola_a_geom) INTO returned_number
FROM cola_markets c WHERE c.name = 'cola_b';
DBMS_OUTPUT.PUT_LINE('Does cola_b overlap cola_a?: ' || returned_number);

SELECT c.shape.ST_CONTAINS(cola_a_geom) INTO returned_number
FROM cola_markets c WHERE c.name = 'cola_b';
DBMS_OUTPUT.PUT_LINE('Does cola_b contain cola_a?: ' || returned_number);

SELECT c.shape.ST_INTERSECTION(cola_a_geom) INTO returned_geom
FROM cola_markets c WHERE c.name = 'cola_b';

SELECT c.shape.ST_DIFFERENCE(cola_a_geom) INTO returned_geom
FROM cola_markets c WHERE c.name = 'cola_b';

SELECT c.shape.ST_UNION(cola_a_geom) INTO returned_geom
FROM cola_markets c WHERE c.name = 'cola_b';

SELECT c.shape.ST_SYMDIFFERENCE(cola_a_geom) INTO returned_geom
FROM cola_markets c WHERE c.name = 'cola_b';

SELECT c.shape.ST_TOUCHES(cola_a_geom) INTO returned_number
FROM cola_markets c WHERE c.name = 'cola_b';
DBMS_OUTPUT.PUT_LINE('Does cola_b touch cola_a?: ' || returned_number);

SELECT c.shape.ST_CROSSES(cola_a_geom) INTO returned_number
```



```

FROM cola_markets c WHERE c.name = 'cola_b';
DBMS_OUTPUT.PUT_LINE('Does cola_b cross cola_a?: ' || returned_number);

END;
/

```

3.2 ST_xxx Functions and Spatial Counterparts

Table 3–1 lists SQL Multimedia functions and the comparable Oracle Spatial SDO_GEOMETRY method or Spatial function, procedure, operator. Note that in some cases the Oracle Spatial counterpart has more features than the SQL Multimedia function.

Table 3–1 ST_xxx Functions and Spatial Counterparts

SQL Multimedia Function	Comparable Oracle Spatial Interface
FROM_WKB	SDO_UTIL.FROM_WKBGEOMETRY
FROM_WKT	SDO_UTIL.FROM_WKTGEOMETRY
GET_WKB	SDO_GEOMETRY.Get_WKB
GET_WKT	SDO_GEOMETRY.Get_WKT
ST_BUFFER	SDO_GEOM.SDO_BUFFER
ST_CENTROID	SDO_GEOM.SDO_CENTROID
ST_CONTAINS	SDO_GEOM.RELATE with mask=CONTAINS
ST_CONVEXHULL	SDO_GEOM.SDO_CONVEXHULL
ST_COORDDIM	SDO_GEOMETRY.Get_Dims and SDO_GEOMETRY.ST_CoordDim (equivalent)
ST_CROSS	(None predefined; requires using SDO_GEOM.RELATE with a complex mask)
ST_CROSSES	(None predefined; requires using SDO_GEOM.RELATE with a complex mask)
ST_DIFFERENCE	SDO_GEOM.SDO_DIFFERENCE
ST_DIMENSION	SDO_GEOMETRY.Get_Dims
ST_DISJOINT	SDO_GEOM.RELATE with mask=DISJOINT
ST_DISTANCE	SDO_GEOM.SDO_DISTANCE
ST_ENVELOPE	SDO_GEOM.SDO_MBR
ST_EQUALS	SDO_GEOM.RELATE with mask=EQUAL
ST_GEOMETRYTYPE	SDO_GEOMETRY.Get_GType
ST_INTERSECTION	SDO_GEOM.SDO_INTERSECTION
ST_INTERSECTS	SDO_GEOM.RELATE with mask=OVERLAPBDYDISJOINT + OVERLAPBDYINTERSECT
ST_ISVALID	SDO_GEOM.VALIDATE_GEOMETRY_WITH_CONTEXT
ST_OVERLAP	SDO_GEOM.RELATE with mask=CONTAINS
ST_RELATE	SDO_RELATE , SDO_GEOM.RELATE
ST_SYMDIFFERENCE	SDO_GEOM.SDO_XOR
ST_SYMMETRICDIFFERENCE	SDO_GEOM.SDO_XOR
ST_TOUCH	SDO_GEOM.RELATE with mask=TOUCH

Table 3–1 (Cont.) ST_xxx Functions and Spatial Counterparts

SQL Multimedia Function	Comparable Oracle Spatial Interface
ST_TOUCHES	SDO_GEOM.RELATE with mask=TOUCH
ST_UNION	SDO_GEOM.SDO_UNION
ST_WITHIN	SDO_GEOM.RELATE with mask=COVERS+CONTAINS

3.3 Tolerance Value with SQL Multimedia Types

Because the SQL Multimedia standard does not define how tolerance is to be used with the ST_xxx, Spatial uses a default value of 0.005 in all the member methods of the ST_GEOMETRY type. If you want to specify a different tolerance value to be used with ST_GEOMETRY member functions, override the default by inserting the desired value into the SDO_ST_TOLERANCE table.

The SDO_ST_TOLERANCE table is a global temporary table that should have a single row specifying the tolerance to be used with ST_GEOMETRY member methods. This table has a single column, defined as (tolerance NUMBER).

For all Spatial operators that use a spatial index, Spatial uses the tolerance value specified for the spatial column in the USER_SDO_GEOM_METADATA view.

3.4 Avoiding Name Conflicts

Some third-party vendors support their own version of ST_xxx types on Oracle. For example, a vendor might create its own version of the ST_GEOMETRY type.

To avoid possible conflicts between third-party names and Oracle-supplied names, any third-party implementation of ST_xxx types on Oracle should use a schema prefix. For example, this will ensure that if someone specifies a column type as just ST_GEOMETRY, the column will be created with the Oracle implementation of the ST_GEOMETRY type.

3.5 Annotation Text Type and Views

Oracle Spatial supports annotation text as specified in the *OpenGIS Implementation Specification for Geographic information - Simple feature access - Part 1: Common architecture*, which defines **annotation text** as "simply placed text that can carry either geographically-related or ad-hoc data and process-related information as displayable text. This text may be used for display in editors or in simpler maps. It is usually lacking in full cartographic quality, but may act as an approximation to such text as needed by any application."

The ST_ANNOTATION_TEXT object type can be used to store annotation text. This type has a constructor for inserting annotation text into a table, as explained in [Section 3.5.1](#).

The USER_ANNOTATION_TEXT_METADATA and ALL_ANNOTATION_TEXT_METADATA views store metadata related to annotation text, as explained in [Section 3.5.2](#).

3.5.1 Using the ST_ANNOTATION_TEXT Constructor

An annotation text object contains an array of objects, where each object consists of a text label, the point at which to start rendering the text label, a leader line (typically from the text label to the associated point on the map), and optionally extra attribute

information. A single annotation text object may typically contain all the text labels for a map.

Each text label object has the following definition:

Name	Null?	Type
PRIVATEVALUE		VARCHAR2 (4000)
PRIVATELOCATION		MDSYS.SDO_GEOMETRY
PRIVATELEADERLINE		MDSYS.SDO_GEOMETRY
PRIVATETEXTATTRIBUTES		VARCHAR2 (4000)

To insert the annotation for a single point, use the `ST_ANNOTATION_TEXT` constructor. This constructor specifies the information for a single point using an array, as shown in [Example 3-3](#), which creates a table with a column of type `ST_ANNOTATION_TEXT` and inserts one row, using the `ST_ANNOTATION_TEXT` constructor in the `INSERT` statement.

Example 3-3 Using the `ST_ANNOTATION_TEXT` Constructor

```
CREATE TABLE my_annotations (id NUMBER, textobj ST_ANNOTATION_TEXT);

INSERT INTO my_annotations VALUES (2,
  ST_ANNOTATION_TEXT(
    ST_ANNOTATIONTEXTELEMENT_ARRAY(
      ST_ANNOT_TEXTELEMENT_ARRAY(
        ST_ANNOTATIONTEXTELEMENT(
          'Sample Label 2',
          SDO_GEOMETRY(2001,null,sdo_point_type(10,10,null),null,null),
          SDO_GEOMETRY(2002,null,null,
            SDO_ELEM_INFO_ARRAY(1,2,1),
            SDO_ORDINATE_ARRAY(5,10, 10,10)),
          NULL))));
```

In the `ST_ANNOTATION_TEXT` constructor in [Example 3-3](#), the `ST_ANNOTATIONTEXTELEMENT` subelement specifies the following:

- The text for the label, in this case `Sample Label 2`
- A point geometry specifying where to start rendering the label, in this case location (10,10)
- A line string geometry specifying the start and end points of the leader line between the point of interest and the text label, in this case a line between locations (5,10) and (10,10)
- No text display attribute information (NULL), which means that the information `TEXT_ATTRIBUTES` column of the annotation text metadata views is used (see [Table 3-2](#) in [Section 3.5.2](#))

3.5.2 Annotation Text Metadata Views

The annotation text metadata is stored in a global table owned by `MDSYS` (which users should never directly update). Each Spatial user has the following views available in the schema associated with that user:

- `USER_ANNOTATION_TEXT_METADATA` contains metadata information for all annotation text in tables owned by the user (schema). This is the only view that you can update, and it is the one in which Spatial users must insert metadata related to spatial tables.

- ALL_ANNOTATION_TEXT_METADATA contains metadata information for all annotation text in tables on which the user has SELECT permission.

Spatial users are responsible for populating these views. For each annotation text object, you must insert an appropriate row into the USER_ANNOTATION_TEXT_METADATA view. Oracle Spatial ensures that the ALL_ANNOTATION_TEXT_METADATA view is also updated to reflect the rows that you insert into USER_ANNOTATION_TEXT_METADATA.

The USER_ANNOTATION_TEXT_METADATA and ALL_ANNOTATION_TEXT_METADATA views contain the same columns, as shown [Table 3–2](#), except that the USER_ANNOTATION_TEXT_METADATA view does not contain the OWNER column. (The columns are listed in their order in the view definition.)

Table 3–2 Columns in the Annotation Text Metadata Views

Column Name	Data Type	Purpose
OWNER	VARCHAR2(32)	Owner of the table specified in the TABLE_NAME column (ALL_ANNOTATION_TEXT_METADATA view only).
TABLE_NAME	VARCHAR2(32)	Name of the table containing the column of type ST_ANNOTATION_TEXT.
COLUMN_NAME	VARCHAR2(1024)	Name of the column of type ST_ANNOTATION_TEXT.
TEXT_EXPRESSION	VARCHAR2(4000)	A value that can be used if text is not specified for a label. As explained in the OpenGIS specification: "Text to place is first derived from the contents of VALUE in the current element, if VALUE is not null. Otherwise, text is derived from the first non-null preceding element VALUE. If all preceding elements have null VALUE fields, VALUE is derived from the TEXT_EXPRESSION in the metadata table."
TEXT_ATTRIBUTES	VARCHAR2(4000)	Default text display attributes (font family and size, horizontal and vertical spacing, and so on) for the label text style and layout, unless overridden in the PRIVATETEXTATTRIBUTES attribute of the ST_ANNOTATION_TEXT constructor (described in Section 3.5.1). Use the format specified in the "XML for Text Attributes" section of the OpenGIS specification.

Loading Spatial Data

This chapter describes how to load spatial data into a database, including storing the data in a table with a column of type `SDO_GEOMETRY`. After you have loaded spatial data, you can create a spatial index for it and perform queries on it, as described in [Chapter 5](#).

The process of loading data can be classified into two categories:

- Bulk loading of data (see [Section 4.1](#))
This process is used to load large volumes of data into the database and uses the `SQL*Loader` utility to load the data.
- Transactional insert operations (see [Section 4.2](#))
This process is typically used to insert relatively small amounts of data into the database using the `INSERT` statement in SQL.

Recommendations for loading and validating spatial data are described in [Section 4.3](#).

4.1 Bulk Loading

Bulk loading can import large amounts of data into an Oracle database. Bulk loading is accomplished with the `SQL*Loader` utility. (For information about `SQL*Loader`, see *Oracle Database Utilities*.)

4.1.1 Bulk Loading `SDO_GEOMETRY` Objects

[Example 4-1](#) is the `SQL*Loader` control file for loading four geometries. When this control file is used with `SQL*Loader`, it loads the same cola market geometries that are inserted using SQL statements in [Example 2-1](#) in [Section 2.1](#).

Example 4-1 Control File for a Bulk Load of Cola Market Geometries

```
LOAD DATA
INFILE *
TRUNCATE
CONTINUEIF NEXT(1:1) = '#'
INTO TABLE COLA_MARKETS
FIELDS TERMINATED BY '|'
TRAILING NULLCOLS (
mkt_id INTEGER EXTERNAL,
name CHAR,
shape COLUMN OBJECT
(
SDO_GTYPE INTEGER EXTERNAL,
SDO_ELEM_INFO VARRAY TERMINATED BY '|/'
```



```

begindata
  1|2003|1|1003|1|/
#-122.4215|37.7862|-122.422|37.7869|-122.421|37.789|-122.42|37.7866|
#-122.4215|37.7862|/
  2|2003|1|1003|1|/
#-122.4019|37.8052|-122.4027|37.8055|-122.4031|37.806|-122.4012|37.8052|
#-122.4019|37.8052|/
  3|2003|1|1003|1|/
#-122.426|37.803|-122.4242|37.8053|-122.42355|37.8044|-122.4235|37.8025|
#-122.426|37.803|/

```

4.1.2 Bulk Loading Point-Only Data in SDO_GEOMETRY Objects

[Example 4-3](#) shows a control file for loading a table with point data.

Example 4-3 Control File for a Bulk Load of Point-Only Data

```

LOAD DATA
  INFILE *
  TRUNCATE
  CONTINUEIF NEXT(1:1) = '#'
  INTO TABLE POINT
  FIELDS TERMINATED BY '|'
  TRAILING NULLCOLS (
    GID      INTEGER EXTERNAL,
    GEOMETRY COLUMN OBJECT
  (
    SDO_GTYPE      INTEGER EXTERNAL,
    SDO_POINT COLUMN OBJECT
    (X      FLOAT EXTERNAL,
     Y      FLOAT EXTERNAL)
  )
)

BEGINDATA
  1|
200
1| -122.4215| 37.7862|
  2|
200
1| -122.4019| 37.8052|
  3|
200
1| -122.426| 37.803|
  4|
200
1| -122.4171| 37.8034|
  5|
200
1| -122.416151| 37.8027228|

```

4.2 Transactional Insert Operations Using SQL

Oracle Spatial uses standard Oracle tables that can be accessed or loaded with standard SQL syntax. This section contains examples of transactional insertions into columns of type SDO_GEOMETRY. This process is typically used to add relatively small amounts of data into the database.

The INSERT statement in Oracle SQL has a limit of 999 arguments. Therefore, you cannot create a variable-length array of more than 999 elements using the SDO_GEOMETRY constructor inside a transactional INSERT statement; however, you can insert a geometry using a host variable, and the host variable can be built using the SDO_GEOMETRY constructor with more than 999 values in the SDO_ORDINATE_ARRAY specification. (The host variable is an OCI, PL/SQL, or Java program variable.)

To perform transactional insertions of geometries, you can create a procedure to insert a geometry, and then invoke that procedure on each geometry to be inserted.

[Example 4-4](#) creates a procedure to perform the insert operation.

Example 4-4 Procedure to Perform a Transactional Insert Operation

```
CREATE OR REPLACE PROCEDURE
    INSERT_GEOM(GEOM SDO_GEOMETRY)
IS
BEGIN
    INSERT INTO TEST_1 VALUES (GEOM);
    COMMIT;
END;
/
```

Using the procedure created in [Example 4-4](#), you can insert data by using a PL/SQL block, such as the one in [Example 4-5](#), which loads a geometry into the variable named `geom` and then invokes the INSERT_GEOM procedure to insert that geometry.

Example 4-5 PL/SQL Block Invoking a Procedure to Insert a Geometry

```
DECLARE
geom SDO_geometry :=
    SDO_geometry (2003, null, null,
        SDO_elem_info_array (1,1003,3),
        SDO_ordinate_array (-109,37,-102,40));
BEGIN
    INSERT_GEOM(geom);
    COMMIT;
END;
/
```

For additional examples with various geometry types, see the following:

- Rectangle: [Example 2-6](#) in [Section 2.7.1](#)
- Polygon with a hole: [Example 2-7](#) in [Section 2.7.2](#)
- Compound line string: [Example 2-8](#) in [Section 2.7.3](#)
- Compound polygon: [Example 2-9](#) in [Section 2.7.4](#)
- Point: [Example 2-10](#) and [Example 2-11](#) in [Section 2.7.5](#)
- Oriented point: [Example 2-12](#) in [Section 2.7.6](#)
- Type 0 (zero) element: [Example 2-14](#) in [Section 2.7.7](#)

4.3 Recommendations for Loading and Validating Spatial Data

The recommended procedure for loading and validating spatial data is as follows:

1. Load the data, using a method described in [Section 4.1](#) or [Section 4.2](#).

2. Use the [SDO_GEOM.VALIDATE_GEOMETRY_WITH_CONTEXT](#) function or the [SDO_GEOM.VALIDATE_LAYER_WITH_CONTEXT](#) procedure on all spatial data loaded into the database.
3. For any geometries with the wrong orientation or an invalid ETYPE or GTYPE value, use [SDO_MIGRATE.TO_CURRENT](#) on these invalid geometries to fix them.
4. For any geometries that are invalid for other reasons, use [SDO_UTIL.RECTIFY_GEOMETRY](#) to fix these geometries.

For detailed information about using any of these subprograms, see the usage notes in its reference information section.

Indexing and Querying Spatial Data

After you have loaded spatial data (discussed in [Chapter 4](#)), you should create a spatial index on it to enable efficient query performance using the data. This chapter describes how to:

- Create a spatial index (see [Section 5.1](#))
- Query spatial data efficiently, based on an understanding of the Oracle Spatial query model and primary and secondary filtering (see [Section 5.2](#))

5.1 Creating a Spatial Index

Once data has been loaded into the spatial tables through either bulk or transactional loading, a spatial index (that is, a spatial R-tree index) must be created on each geometry column in the tables for efficient access to the data. For example, the following statement creates a spatial index named `territory_idx` using default values for all parameters:

```
CREATE INDEX territory_idx ON territories (territory_geom)
  INDEXTYPE IS MDSYS.SPATIAL_INDEX;
```

For detailed information about options for creating a spatial index, see the documentation for the [CREATE INDEX](#) statement in [Chapter 18](#).

If the index creation does not complete for any reason, the index is invalid and must be deleted with the [DROP INDEX](#) `<index_name>` [FORCE] statement.

Within each geometry column to be indexed, all the geometries must have the same `SDO_SRID` value.

Spatial indexes can be built on two, three, or four dimensions of data. The default number of dimensions is two, but if the data has more than two dimensions, you can use the `sdo_indx_dims` parameter keyword to specify the number of dimensions on which to build the index. (For information about support for three-dimensional geometries, see [Section 1.11](#). For an explanation of support for various combinations of dimensionality in query elements, see [Section 5.2.3](#).)

If you are *not* using the automatic undo management feature or the PGA memory management feature, or both, of Oracle Database, see [Section 5.1.7](#) for information about initialization parameter values that you may need to set. Both automatic undo management and PGA memory management are enabled by default, and their use is highly recommended.

The tablespace specified with the `tablespace` keyword in the [CREATE INDEX](#) statement (or the default tablespace if the `tablespace` keyword is not specified) is used to hold both the index data table and some transient tables that are created for

internal computations. If you specify `WORK_TABLESPACE` as the tablespace, the transient tables are stored in the work tablespace.

For large tables (over 1 million rows), a temporary tablespace may be needed to perform internal sorting operations. The recommended size for this temporary tablespace is $100*n$ bytes, where n is the number of rows in the table, up to a maximum requirement of 1 gigabyte of temporary tablespace.

To estimate the space that will be needed to create a spatial index, use the `SDO_TUNE.ESTIMATE_RTREE_INDEX_SIZE` function, described in [Chapter 31](#).

5.1.1 Constraining Data to a Geometry Type

When you create or rebuild a spatial index, you can ensure that all geometries that are in the table or that are inserted later are of a specified geometry type. To constrain the data to a geometry type in this way, use the `layer_gtype` keyword in the `PARAMETERS` clause of the `CREATE INDEX` or `ALTER INDEX REBUILD` statement, and specify a value from the Geometry Type column of [Table 2-1](#) in [Section 2.2.1](#). For example, to constrain spatial data in a layer to polygons:

```
CREATE INDEX cola_spatial_idx
ON cola_markets(shape)
INDEXTYPE IS MDSYS.SPATIAL_INDEX
PARAMETERS ('layer_gtype=POLYGON');
```

The geometry types in [Table 2-1](#) are considered as a hierarchy when data is checked:

- The *MULTI* forms include the regular form also. For example, specifying `'layer_gtype=MULTIPOINT'` allows the layer to include both `POINT` and `MULTIPOINT` geometries.
- `COLLECTION` allows the layer to include all types of geometries.

5.1.2 Creating a Cross-Schema Index

You can create a spatial index on a table that is not in your schema. Assume that user B wants to create a spatial index on column `GEOMETRY` in table `T1` under user A's schema. Follow these steps:

1. Connect to the database as a privileged user (for example, as `SYSTEM`), and execute the following statement:

```
GRANT create table, create sequence to B;
```
2. Connect as a privileged user or as user A (or have user A connect), and execute the following statement:

```
GRANT select, index on A.T1 to B;
```
3. Connect as user B and execute a statement such as the following:

```
CREATE INDEX t1_spatial_idx on A.T1(geometry)
INDEXTYPE IS mdsys.spatial_index;
```

5.1.3 Using Partitioned Spatial Indexes

You can create a partitioned spatial index on a partitioned table. This section describes usage considerations specific to Oracle Spatial. For a detailed explanation of partitioned tables and partitioned indexes, see *Oracle Database Administrator's Guide*.

A partitioned spatial index can provide the following benefits:

- Reduced response times for long-running queries, because partitioning reduces disk I/O operations
- Reduced response times for concurrent queries, because I/O operations run concurrently on each partition
- Easier index maintenance, because of partition-level create and rebuild operations
Indexes on partitions can be rebuilt without affecting the queries on other partitions, and storage parameters for each local index can be changed independent of other partitions.
- Parallel query on multiple partition searching
The degree of parallelism is the value from the DEGREE column in the row for the index in the USER_INDEXES view (that is, the value specified or defaulted for the PARALLEL keyword with the [CREATE INDEX](#), [ALTER INDEX](#), or [ALTER INDEX REBUILD](#) statement).
- Improved query processing in multiprocessor system environments
In a multiprocessor system environment, if a spatial operator is invoked on a table with partitioned spatial index and if multiple partitions are involved in the query, multiple processors can be used to evaluate the query. The number of processors used is determined by the degree of parallelism and the number of partitions used in evaluating the query.

The following restrictions apply to spatial index partitioning:

- The partition key for spatial tables must be a scalar value, and must not be a spatial column.
- Only range partitioning is supported on the underlying table. All other kinds of partitioning are not currently supported for partitioned spatial indexes.

To create a partitioned spatial index, you must specify the LOCAL keyword. (If you do not specify the LOCAL keyword, a nonpartitioned spatial index is created on the data in all table partitions.) The following example creates a partitioned spatial index:

```
CREATE INDEX counties_idx ON counties(geometry)
  INDEXTYPE IS MDSYS.SPATIAL_INDEX LOCAL;
```

In this example, the default values are used for the number and placement of index partitions, namely:

- Index partitioning is based on the underlying table partitioning. For each table partition, a corresponding index partition is created.
- Each index partition is placed in the default tablespace.

If you do specify parameters for individual partitions, the following considerations apply:

- The storage characteristics for each partition can be the same or different for each partition. If they are different, it may enable parallel I/O (if the tablespaces are on different disks) and may improve performance.
- The `sdo_indx_dims` value must be the same for all partitions.
- The `layer_gtype` parameter value (see [Section 5.1.1](#)) used for each partition may be different.

To override the default partitioning values, use a CREATE INDEX statement with the following general format:

```
CREATE INDEX <indexname> ON <table>(<column>)
```

```

INDEXTYPE IS MDSYS.SPATIAL_INDEX
  [PARAMETERS ('<spatial-params>, <storage-params>')] LOCAL
  [( PARTITION <index_partition>
    PARAMETERS ('<spatial-params>, <storage-params>')
  [, PARTITION <index_partition>
    PARAMETERS ('<spatial-params>, <storage-params>')]
  )]

```

Queries can operate on partitioned tables to perform the query on only one partition. For example:

```

SELECT * FROM counties PARTITION(p1)
  WHERE ...<some-spatial-predicate>;

```

Querying on a selected partition may speed up the query and also improve overall throughput when multiple queries operate on different partitions concurrently.

When queries use a partitioned spatial index, the semantics (meaning or behavior) of spatial operators and functions is the same with partitioned and nonpartitioned indexes, except in the case of [SDO_NN](#) (nearest neighbor). With [SDO_NN](#), the requested number of geometries is returned for each partition that is affected by the query. (See the description of the [SDO_NN](#) operator in [Chapter 19](#) for more information.)

For example, if you request the 5 closest restaurants to a point and the spatial index has 4 partitions, [SDO_NN](#) returns up to 20 (5*4) geometries. In this case, you must use the ROWNUM pseudocolumn (here, `WHERE ROWNUM <=5`) to return the 5 closest restaurants, and the ORDER BY clause to sort the results by distance in miles.

[Example 5-1](#) returns the 5 nearest restaurants from a partitioned spatial index.

Example 5-1 SDO_NN Query with Partitioned Spatial Index

```

SELECT * FROM
(
  SELECT r.name, r.location, SDO_NN_DISTANCE(1) distance_in_miles
  FROM restaurants_part_table r
  WHERE SDO_NN(r.location,
    MDSYS.SDO_GEOMETRY(2001,8307,MDSYS.SDO_POINT_TYPE(-110,35,Null),Null,Null),
    'SDO_NUM_RES=5 distance=2 unit=MILE', 1) = 'TRUE'
  ORDER BY distance_in_miles
)
WHERE ROWNUM<=5;

```

See Also: [Section C.3, "SDO_NN Examples"](#) for more examples of using the [SDO_NN](#) operator.

For a cross-schema query when a table has a partitioned spatial index, the user must be granted SELECT privilege on both the spatial table and the index table (MDRT_XXX) for the spatial index that was created on the spatial table. For more information and an example, see "[Cross-Schema Invocation of SDO_JOIN](#)" in the Usage Notes for the [SDO_JOIN](#) operator in [Chapter 19](#).

5.1.3.1 Creating a Local Partitioned Spatial Index

If you want to create a local partitioned spatial index, Oracle recommends that you use the procedure in this section instead of using the PARALLEL keyword, to avoid having to start over if the creation of any partition's index fails for any reason (for example, because the tablespace is full). Follow these steps:

1. Create a local spatial index and specify the UNUSABLE keyword. For example:

```
CREATE INDEX sp_idx ON my_table (location)
  INDEXTYPE IS mdsys.spatial_index
  PARAMETERS ('tablespace=tb_name work_tablespace=work_tb_name')
  LOCAL UNUSABLE;
```

This statement executes quickly and creates metadata associated with the index.

2. Create scripts with ALTER INDEX REBUILD statements, but without the PARALLEL keyword. For example, if you have 100 partitions and 10 processors, create 10 scripts with 10 ALTER INDEX statements such as the following:

```
ALTER INDEX sp_idx REBUILD PARTITION ip1;
ALTER INDEX sp_idx REBUILD PARTITION ip2;
. . .
ALTER INDEX sp_idx REBUILD PARTITION ip10;
```

3. Run all the scripts at the same time, so that each processor works on the index for a single partition, but all the processors are busy working on their own set of ALTER INDEX statements.

If any of the ALTER INDEX statements fails, you do not need to rebuild any partitions for which the operation has successfully completed.

5.1.4 Exchanging Partitions Including Indexes

You can use the ALTER TABLE statement with the EXCHANGE PARTITION ... INCLUDING INDEXES clause to exchange a spatial table partition and its index partition with a corresponding table and its index. For information about exchanging partitions, see the description of the ALTER TABLE statement in *Oracle Database SQL Language Reference*.

This feature can help you to operate more efficiently in a number of situations, such as:

- Bringing data into a partitioned table and avoiding the cost of index re-creation.
- Managing and creating partitioned indexes. For example, the data could be divided into multiple tables. The index for each table could be built one after the other to minimize the memory and tablespace resources needed during index creation. Alternately, the indexes could be created in parallel in multiple sessions. The tables (along with the indexes) could then be exchanged with the partitions of the original data table.
- Managing offline insert operations. New data can be stored in a temporary table and periodically exchanged with a new partition (for example, in a database with historical data).

To exchange partitions including indexes with spatial data and indexes, the two spatial indexes (one on the partition, the other on the table) must have the same dimensionality (`sdo_indx_dims` value). If the indexes do not have the same dimensionality, an error is raised. The table data is exchanged, but the indexes are not exchanged and the indexes are marked as failed. To use the indexes, you must rebuild them

5.1.5 Export and Import Considerations with Spatial Indexes and Data

If you use the Export utility to export tables with spatial data, the behavior of the operation depends on whether or not the spatial data has been spatially indexed:

- If the spatial data has not been spatially indexed, the table data is exported. However, you must update the USER_SDO_GEOM_METADATA view with the appropriate information on the target system.
- If the spatial data has been spatially indexed, the table data is exported, the appropriate information is inserted into the USER_SDO_GEOM_METADATA view on the target system, and the spatial index is built on the target system. However, if the insertion into the USER_SDO_GEOM_METADATA view fails (for example, if there is already a USER_SDO_GEOM_METADATA entry for the spatial layer), the spatial index is not built.

If you use the Import utility to import data that has been spatially indexed, the following considerations apply:

- If the index on the exported data was created with a TABLESPACE clause and if the specified tablespace does not exist in the database at import time, the index is not built. (This is different from the behavior with other Oracle indexes, where the index is created in the user's default tablespace if the tablespace specified for the original index does not exist at import time.)
- If the import operation must be done by a privileged database user, and if the FROMUSER and TOUSER format is used, the TOUSER user must be granted the CREATE TABLE and CREATE SEQUENCE privileges before the import operation, as shown in the following example (and enter the password for the SYSTEM account when prompted):

```
sqlplus system
SQL> grant CREATE TABLE, CREATE SEQUENCE to CHRIS;
SQL> exit;
imp system file=spatl_data.dmp fromuser=SCOTT touser=CHRIS
```

For information about using the Export and Import utilities, see *Oracle Database Utilities*.

5.1.6 Distributed Transactions and Spatial Index Consistency

In a distributed transaction, different branches of the transaction can execute in different sessions. The branches can detach from their current session and migrate to another within the transaction scope. To maintain the consistency of Spatial indexes in distributed transactions, you must follow the usage guidelines in this section.

When the first insert, update, or delete operation on a spatial table (one with a spatial index) is performed in a distributed transaction, all subsequent insert, update, or delete operations on the table, as well as any prepare to commit operation (the first branch to prepare a commit), in the transaction should happen *in the same session* as the first operation. The branches performing these subsequent operations will first have to connect to the session in which the first operation was performed.

For more information about distributed transactions, see *Oracle Database Administrator's Guide*.

5.1.7 Rollback Segments and Sort Area Size

This section applies *only* if you (or the database administrator) are not using the automatic undo management feature or the PGA memory management feature, or both, of Oracle Database. Automatic memory management and PGA memory management are enabled by default, and their use is highly recommended. For explanations of these features, see:

- The section about automatic undo management and undo segments in *Oracle Database Concepts*
- The section about PGA memory management in *Oracle Database Concepts*

If you are not using automatic undo management and if the rollback segment is not large enough, an attempt to create a spatial index will fail. The rollback segment should be $100*n$ bytes, where n is the number of rows of data to be indexed. For example, if the table contains 1 million (1,000,000) rows, the rollback segment size should be 100,000,000 (100 million) bytes.

To ensure an adequate rollback segment, or if you have tried to create a spatial index and received an error that a rollback segment cannot be extended, review (or have a DBA review) the size and structure of the rollback segments. Create a public rollback segment of the appropriate size, and place that rollback segment online. In addition, ensure that any small inappropriate rollback segments are placed offline during large spatial index operations.

If you are not using the PGA memory management feature, the system parameter `SORT_AREA_SIZE` affects the amount of time required to create the index. The `SORT_AREA_SIZE` value is the maximum amount, in bytes, of memory to use for a sort operation. The optimal value depends on the database size, but a good guideline is to make it at least 1 million bytes when you create a spatial index. To change the `SORT_AREA_SIZE` value, use the `ALTER SESSION` statement. For example, to change the value to 20 million bytes:

```
ALTER SESSION SET SORT_AREA_SIZE = 20000000;
```

5.2 Querying Spatial Data

This section describes how the structures of a Spatial layer are used to resolve spatial queries and spatial joins.

Spatial uses a two-tier query model with primary and secondary filter operations to resolve spatial queries and spatial joins, as explained in [Section 1.6](#). The term *two-tier* indicates that two distinct operations are performed to resolve queries. If both operations are performed, the exact result set is returned.

You cannot append a database link (dblink) name to the name of a spatial table in a query if a spatial index is defined on that table.

5.2.1 Spatial Query

In a spatial R-tree index, each geometry is represented by its minimum bounding rectangle (MBR), as explained in [Section 1.7.1](#). Consider the following layer containing several objects in [Figure 5–1](#). Each object is labeled with its geometry name (geom_1 for the line string, geom_2 for the four-sided polygon, geom_3 for the triangular polygon, and geom_4 for the ellipse), and the MBR around each object is represented by a dashed line.

Figure 5–1 Geometries with MBRs

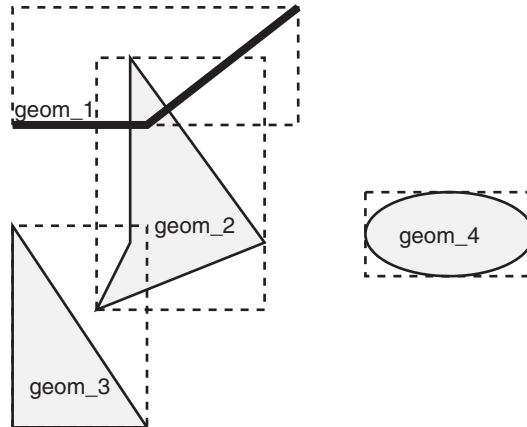

A typical spatial query is to request all objects that lie within a **query window**, that is, a defined fence or window. A dynamic query window refers to a rectangular area that is not defined in the database, but that must be defined before it is used. [Figure 5–2](#) shows the same geometries as in [Figure 5–1](#), but adds a query window represented by the heavy dotted-line box.

Figure 5–2 Layer with a Query Window

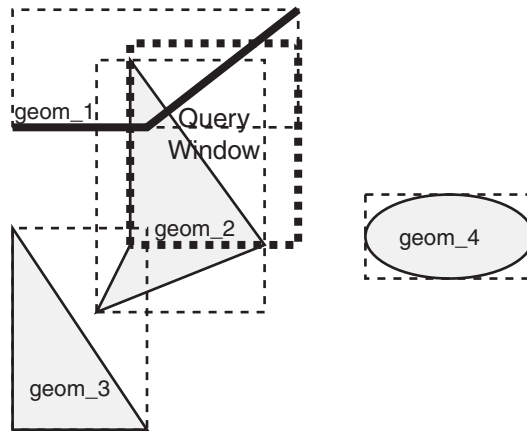

In [Figure 5–2](#), the query window covers parts of geometries **geom_1** and **geom_2**, as well as part of the MBR for **geom_3** but none of the actual **geom_3** geometry. The query window does not cover any part of the **geom_4** geometry or its MBR.

5.2.1.1 Primary Filter Operator

The **SDO_FILTER** operator, described in [Chapter 19](#), implements the primary filter portion of the two-step process involved in the Oracle Spatial query processing model. The primary filter uses the index data to determine only if a set of candidate object pairs may interact. Specifically, the primary filter checks to see if the MBRs of the candidate objects interact, not whether the objects themselves interact. The **SDO_FILTER** operator syntax is as follows:

```
SDO_FILTER(geometry1 SDO_GEOMETRY, geometry2 SDO_GEOMETRY, param VARCHAR2)
```

In the preceding syntax:

- `geometry1` is a column of type `SDO_GEOMETRY` in a table. This column must be spatially indexed.
- `geometry2` is an object of type `SDO_GEOMETRY`. This object may or may not come from a table. If it comes from a table, it may or may not be spatially indexed.
- `param` is an optional string of type `VARCHAR2`. It can specify either or both of the `min_resolution` and `max_resolution` keywords.

The following examples perform a primary filter operation only (with no secondary filter operation). They will return all the geometries shown in [Figure 5-2](#) that have an MBR that interacts with the query window. The result of the following examples are geometries `geom_1`, `geom_2`, and `geom_3`.

[Example 5-2](#) performs a primary filter operation without inserting the query window into a table. The window will be indexed in memory and performance will be very good.

Example 5-2 Primary Filter with a Temporary Query Window

```
SELECT A.Feature_ID FROM TARGET A
WHERE sdo_filter(A.shape, SDO_geometry(2003,NULL,NULL,
                                     SDO_elem_info_array(1,1003,3),
                                     SDO_ordinate_array(x1,y1, x2,y2))
           ) = 'TRUE';
```

In [Example 5-2](#), `(x1, y1)` and `(x2, y2)` are the lower-left and upper-right corners of the query window.

In [Example 5-3](#), a transient instance of type `SDO_GEOMETRY` was constructed for the query window instead of specifying the window parameters in the query itself.

Example 5-3 Primary Filter with a Transient Instance of the Query Window

```
SELECT A.Feature_ID FROM TARGET A
WHERE sdo_filter(A.shape, :theWindow) = 'TRUE';
```

[Example 5-4](#) assumes the query window was inserted into a table called `WINDOWS`, with an ID of `WINS_1`.

Example 5-4 Primary Filter with a Stored Query Window

```
SELECT A.Feature_ID FROM TARGET A, WINDOWS B
WHERE B.ID = 'WINS_1' AND
      sdo_filter(A.shape, B.shape) = 'TRUE';
```

If the `B.SHAPE` column is not spatially indexed, the `SDO_FILTER` operator indexes the query window in memory and performance is very good.

5.2.1.2 Primary and Secondary Filter Operator

The `SDO_RELATE` operator, described in [Chapter 19](#), performs both the primary and secondary filter stages when processing a query. The secondary filter ensures that only candidate objects that actually interact are selected. This operator can be used only if a spatial index has been created on two dimensions of data. The syntax of the `SDO_RELATE` operator is as follows:

```
SDO_RELATE(geometry1 SDO_GEOMETRY,
           geometry2 SDO_GEOMETRY,
           param     VARCHAR2)
```

In the preceding syntax:

- `geometry1` is a column of type `SDO_GEOMETRY` in a table. This column must be spatially indexed.
- `geometry2` is an object of type `SDO_GEOMETRY`. This object may or may not come from a table. If it comes from a table, it may or may not be spatially indexed.
- `param` is a quoted string with the `mask` keyword and a valid mask value, and optionally either or both of the `min_resolution` and `max_resolution` keywords, as explained in the documentation for the [SDO_RELATE](#) operator in [Chapter 19](#).

The following examples perform both primary and secondary filter operations. They return all the geometries in [Figure 5-2](#) that lie within or overlap the query window. The result of these examples is objects `geom_1` and `geom_2`.

[Example 5-5](#) performs both primary and secondary filter operations without inserting the query window into a table. The window will be indexed in memory and performance will be very good.

Example 5-5 Secondary Filter Using a Temporary Query Window

```
SELECT A.Feature_ID FROM TARGET A
      WHERE sdo_relate(A.shape, SDO_geometry(2003,NULL,NULL,
                                           SDO_elem_info_array(1,1003,3),
                                           SDO_ordinate_array(x1,y1, x2,y2)),
                      'mask=anyinteract') = 'TRUE';
```

In [Example 5-5](#), `(x1, y1)` and `(x2, y2)` are the lower-left and upper-right corners of the query window.

[Example 5-6](#) assumes the query window was inserted into a table called `WINDOWS`, with an ID value of `WINS_1`.

Example 5-6 Secondary Filter Using a Stored Query Window

```
SELECT A.Feature_ID FROM TARGET A, WINDOWS B
      WHERE B.ID = 'WINS_1' AND
            sdo_relate(A.shape, B.shape,
                      'mask=anyinteract') = 'TRUE';
```

If the `B.SHAPE` column is not spatially indexed, the [SDO_RELATE](#) operator indexes the query window in memory and performance is very good.

5.2.1.3 Within-Distance Operator

The [SDO_WITHIN_DISTANCE](#) operator, described in [Chapter 19](#), is used to determine the set of objects in a table that are within *n* distance units from a reference object. This operator can be used only if a spatial index has been created on two dimensions of data. The reference object may be a transient or persistent instance of `SDO_GEOMETRY`, such as a temporary query window or a permanent geometry stored in the database. The syntax of the operator is as follows:

```
SDO_WITHIN_DISTANCE(geometry1 SDO_GEOMETRY,
                    aGeom      SDO_GEOMETRY,
                    params      VARCHAR2);
```

In the preceding syntax:

- `geometry1` is a column of type `SDO_GEOMETRY` in a table. This column must be spatially indexed.
- `aGeom` is an instance of type `SDO_GEOMETRY`.
- `params` is a quoted string of keyword value pairs that determines the behavior of the operator. See the [SDO_WITHIN_DISTANCE](#) operator in [Chapter 19](#) for a list of parameters.

The following example selects any objects within 1.35 distance units from the query window:

```
SELECT A.Feature_ID
FROM TARGET A
WHERE SDO_WITHIN_DISTANCE( A.shape, :theWindow, 'distance=1.35') = 'TRUE';
```

The distance units are based on the geometry coordinate system in use. If you are using a geodetic coordinate system, the units are meters. If no coordinate system is used, the units are the same as for the stored data.

The [SDO_WITHIN_DISTANCE](#) operator is not suitable for performing spatial joins. That is, a query such as *Find all parks that are within 10 distance units from coastlines* will not be processed as an index-based spatial join of the `COASTLINES` and `PARKS` tables. Instead, it will be processed as a nested loop query in which each `COASTLINES` instance is in turn a reference object that is buffered, indexed, and evaluated against the `PARKS` table. Thus, the [SDO_WITHIN_DISTANCE](#) operation is performed n times if there are n rows in the `COASTLINES` table.

For non-geodetic data, there is an efficient way to accomplish a spatial join that involves buffering all geometries of a layer. This method does not use the [SDO_WITHIN_DISTANCE](#) operator. First, create a new table `COSINE_BUFS` as follows:

```
CREATE TABLE cosine_bufs UNRECOVERABLE AS
SELECT SDO_BUFFER (A.SHAPE, B.DIMINFO, 1.35)
FROM COSINE A, USER_SDO_GEOM_METADATA B
WHERE TABLE_NAME='COSINES' AND COLUMN_NAME='SHAPE';
```

Next, create a spatial index on the `SHAPE` column of `COSINE_BUFS`. Then you can perform the following query:

```
SELECT /*+ ordered */ a.gid, b.gid
FROM TABLE(SDO_JOIN('PARKS', 'SHAPE',
                    'COSINE_BUFS', 'SHAPE',
                    'mask=ANYINTERACT')) c,
        parks a,
        cosine_bufs b
WHERE c.rowid1 = a.rowid AND c.rowid2 = b.rowid;
```

5.2.1.4 Nearest Neighbor Operator

The [SDO_NN](#) operator, described in [Chapter 19](#), is used to identify the nearest neighbors for a geometry. This operator can be used only if a spatial index has been created on two dimensions of data. The syntax of the operator is as follows:

```
SDO_NN(geometry1 SDO_GEOMETRY,
        geometry2 SDO_GEOMETRY,
        param    VARCHAR2
        [, number NUMBER]);
```

In the preceding syntax:

- `geometry1` is a column of type `SDO_GEOMETRY` in a table. This column must be spatially indexed.
- `geometry2` is an instance of type `SDO_GEOMETRY`.
- `param` is a quoted string of keyword-value pairs that can determine the behavior of the operator, such as how many nearest neighbor geometries are returned. See the `SDO_NN` operator in [Chapter 19](#) for information about this parameter.
- `number` is the same number used in the call to `SDO_NN_DISTANCE`. Use this only if the `SDO_NN_DISTANCE` ancillary operator is included in the call to `SDO_NN`. See the `SDO_NN` operator in [Chapter 19](#) for information about this parameter.

The following example finds the two objects from the `SHAPE` column in the `COLA_MARKETS` table that are closest to a specified point (10,7). (Note the use of the optimizer hint in the `SELECT` statement, as explained in the Usage Notes for the `SDO_NN` operator in [Chapter 19](#).)

```
SELECT /*+ INDEX(coła_markets cola_spatial_idx) */
      c.mkt_id, c.name FROM cola_markets c WHERE SDO_NN(c.shape,
      SDO_geometry(2001, NULL, SDO_point_type(10,7,NULL), NULL,
      NULL), 'sdo_num_res=2') = 'TRUE';
```

5.2.1.5 Spatial Functions

Spatial also supplies functions for determining relationships between geometries, finding information about single geometries, changing geometries, and combining geometries. These functions all take into account two dimensions of source data. If the output value of these functions is a geometry, the resulting geometry will have the same dimensionality as the input geometry, but only the first two dimensions will accurately reflect the result of the operation.

5.2.2 Spatial Join

A **spatial join** is the same as a regular join except that the predicate involves a spatial operator. In Spatial, a spatial join takes place when you compare all geometries of one layer to all geometries of another layer. This is unlike a query window, which compares a single geometry to all geometries of a layer.

Spatial joins can be used to answer questions such as *Which highways cross national parks?*

The following table structures illustrate how the join would be accomplished for this example:

```
PARKS(   GID VARCHAR2(32), SHAPE SDO_GEOMETRY)
HIGHWAYS( GID VARCHAR2(32), SHAPE SDO_GEOMETRY)
```

To perform a spatial join, use the `SDO_JOIN` operator, which is described in [Chapter 19](#). The following spatial join query, to list the `GID` column values of highways and parks where a highway interacts with a park, performs a primary filter operation only (`'mask=FILTER'`), and thus it returns only approximate results:

```
SELECT /*+ ordered */ a.gid, b.gid
      FROM TABLE(SDO_JOIN('PARKS', 'SHAPE',
                          'HIGHWAYS', 'SHAPE',
                          'mask=FILTER')) c,
      parks a,
      highways b
      WHERE c.rowid1 = a.rowid AND c.rowid2 = b.rowid;
```

The following spatial join query requests the same information as in the preceding example, but it performs both primary and secondary filter operations ('mask=ANYINTERACT'), and thus it returns exact results:

```
SELECT /**+ ordered */ a.gid, b.gid
FROM TABLE(SDO_JOIN('PARKS', 'SHAPE',
                    'HIGHWAYS', 'SHAPE',
                    'mask=ANYINTERACT')) c,
           parks a,
           highways b
WHERE c.rowid1 = a.rowid AND c.rowid2 = b.rowid;
```

5.2.3 Data and Index Dimensionality, and Spatial Queries

The elements of a spatial query can, in theory, have the following dimensionality:

- The base table geometries (or `geometry1` in Spatial operator formats) can have two, three, or more dimensions.
- The spatial index created on the base table (or `geometry1`) can be two-dimensional or three-dimensional.
- The query window (or `geometry2` in Spatial operator formats) can have two, three, or more dimensions.

Some combinations of dimensionality among the three elements are supported and some are not. [Table 5–1](#) explains what happens with the possible combinations involving two and three dimensions.

Table 5–1 Data and Index Dimensionality, and Query Support

Base Table (<code>geometry1</code>) Dimensionality	Spatial Index Dimensionality	Query Window (<code>geometry2</code>) Dimensionality	Query Result
2-dimensional	2-dimensional	2-dimensional	Performs a two-dimensional query.
2-dimensional	2-dimensional	3-dimensional	Supported if the query window has an appropriate <code>SDO_GTYPE</code> value less than 3008.
2-dimensional	3-dimensional	2-dimensional	Not supported: 3D index not permitted on 2D data.
2-dimensional	3-dimensional	3-dimensional	Not supported: 3D index not permitted on 2D data.
3-dimensional	2-dimensional	2-dimensional	Ignores the third (Z) dimension in each base geometry and performs a two-dimensional query.
3-dimensional	2-dimensional	3-dimensional	Supported if the query window has an appropriate <code>SDO_GTYPE</code> value less than 3008.
3-dimensional	3-dimensional	2-dimensional	Converts the 2D query window to a 3D window with zero Z values and performs a three-dimensional query.
3-dimensional	3-dimensional	3-dimensional	Performs a three-dimensional query.

Coordinate Systems (Spatial Reference Systems)

This chapter describes in greater detail the Oracle Spatial coordinate system support, which was introduced in [Section 1.5.4](#). You can store and manipulate SDO_GEOMETRY objects in a variety of coordinate systems.

For reference information about coordinate system transformation functions and procedures in the MDSYS.SDO_CS package, see [Chapter 21](#).

This chapter contains the following major sections:

- [Section 6.1, "Terms and Concepts"](#)
- [Section 6.2, "Geodetic Coordinate Support"](#)
- [Section 6.3, "Local Coordinate Support"](#)
- [Section 6.4, "EPSG Model and Spatial"](#)
- [Section 6.5, "Three-Dimensional Coordinate Reference System Support"](#)
- [Section 6.6, "TFM_PLAN Object Type"](#)
- [Section 6.7, "Coordinate Systems Data Structures"](#)
- [Section 6.8, "Legacy Tables and Views"](#)
- [Section 6.9, "Creating a User-Defined Coordinate Reference System"](#)
- [Section 6.10, "Notes and Restrictions with Coordinate Systems Support"](#)
- [Section 6.11, "U.S. National Grid Support"](#)
- [Section 6.12, "Google Maps Considerations"](#)
- [Section 6.13, "Example of Coordinate System Transformation"](#)

6.1 Terms and Concepts

This section explains important terms and concepts related to coordinate system support in Oracle Spatial.

6.1.1 Coordinate System (Spatial Reference System)

A **coordinate system** (also called a *spatial reference system*) is a means of assigning coordinates to a location and establishing relationships between sets of such coordinates. It enables the interpretation of a set of coordinates as a representation of a position in a real world space.

The term **coordinate reference system** has the same meaning as coordinate system for Spatial, and the terms are used interchangeably. European Petroleum Survey Group (EPSG) specifications and documentation typically use the term coordinate reference system. (EPSG has its own meaning for the term *coordinate system*, as noted in [Section 6.7.11.](#))

6.1.2 Cartesian Coordinates

Cartesian coordinates are coordinates that measure the position of a point from a defined origin along axes that are perpendicular in the represented two-dimensional or three-dimensional space.

6.1.3 Geodetic Coordinates (Geographic Coordinates)

Geodetic coordinates (sometimes called *geographic coordinates*) are angular coordinates (longitude and latitude), closely related to spherical polar coordinates, and are defined relative to a particular Earth geodetic datum (described in [Section 6.1.6](#)). For more information about geodetic coordinate support, see [Section 6.2](#).

6.1.4 Projected Coordinates

Projected coordinates are planar Cartesian coordinates that result from performing a mathematical mapping from a point on the Earth's surface to a plane. There are many such mathematical mappings, each used for a particular purpose.

6.1.5 Local Coordinates

Local coordinates are Cartesian coordinates in a non-Earth (non-georeferenced) coordinate system. [Section 6.3](#) describes local coordinate support in Spatial.

6.1.6 Geodetic Datum

A **geodetic datum** (or **datum**) is a means of shifting and rotating an ellipsoid to represent the figure of the Earth, usually as an oblate spheroid, that approximates the surface of the Earth locally or globally, and is the reference for the system of geodetic coordinates.

Each geodetic coordinate system is based on a datum.

6.1.7 Transformation

Transformation is the conversion of coordinates from one coordinate system to another coordinate system.

If the coordinate system is georeferenced, transformation can involve datum transformation: the conversion of geodetic coordinates from one geodetic datum to another geodetic datum, usually involving changes in the shape, orientation, and center position of the reference ellipsoid.

6.2 Geodetic Coordinate Support

Effective with Oracle9i, Spatial provides a rational and complete treatment of geodetic coordinates. Before Oracle9i, Spatial computations were based solely on flat (Cartesian) coordinates, regardless of the coordinate system specified for the layer of geometries. Consequently, computations for data in geodetic coordinate systems were

inaccurate, because they always treated the coordinates as if they were on a flat surface, and they did not consider the curvature of the surface.

Effective with release 9.2, ellipsoidal surface computations consider the curvatures of the Earth in the specified geodetic coordinate system and return correct, accurate results. In other words, Spatial queries return the right answers all the time.

6.2.1 Geodesy and Two-Dimensional Geometry

A two-dimensional geometry is a surface geometry, but the important question is: What is the *surface*? A flat surface (plane) is accurately represented by Cartesian coordinates. However, Cartesian coordinates are not adequate for representing the surface of a solid. A commonly used surface for spatial geometry is the surface of the Earth, and the laws of geometry there are different than they are in a plane. For example, on the Earth's surface there are no parallel lines: lines are geodesics, and all geodesics intersect. Thus, closed curved surface problems cannot be done accurately with Cartesian geometry.

Spatial provides accurate results regardless of the coordinate system or the size of the area involved, without requiring that the data be projected to a flat surface. The results are accurate regardless of where on the Earth's surface the query is focused, even in "special" areas such as the poles. Thus, you can store coordinates in any datum and projections that you choose, and you can perform accurate queries regardless of the coordinate system.

6.2.2 Choosing a Geodetic or Projected Coordinate System

For applications that deal with the Earth's surface, the data can be represented using a geodetic coordinate system or a projected plane coordinate system. In deciding which approach to take with the data, consider any needs related to accuracy and performance:

- Accuracy

For many spatial applications, the area is sufficiently small to allow adequate computations on Cartesian coordinates in a local projection. For example, the New Hampshire State Plane local projection provides adequate accuracy for most spatial applications that use data for that state.

However, Cartesian computations on a plane projection will never give accurate results for a large area such as Canada or Scandinavia. For example, a query asking if Stockholm, Sweden and Helsinki, Finland are within a specified distance may return an incorrect result if the specified distance is close to the actual measured distance. Computations involving large areas or requiring very precise accuracy must account for the curvature of the Earth's surface.

- Performance

Spherical computations use more computing resources than Cartesian computations. Some operations using geodetic coordinates may take longer to complete than the same operations using Cartesian coordinates.

6.2.3 Choosing Non-Ellipsoidal or Ellipsoidal Height

This section discusses guidelines for choosing the appropriate type of height for three-dimensional data: non-ellipsoidal or ellipsoidal. Although ellipsoidal height is widely used and is the default for many GPS applications, and although ellipsoidal computations incur less performance overhead in many cases, there are applications for which a non-ellipsoidal height may be preferable or even necessary.

Also, after any initial decision, you can change the reference height type, because transformations between different height datums are supported.

6.2.3.1 Non-Ellipsoidal Height

Non-ellipsoidal height is measured from some point other than the reference ellipsoid. Some common non-ellipsoidal measurements of height are from ground level, mean sea level (MSL), or the reference geoid.

- **Ground level:** Measuring height from the ground level is conceptually the simplest approach, and it is common in very local or informal applications. For example, when modeling a single building or a cluster of buildings, ground level may be adequate.

Moreover, if you ever need to integrate local ground height with a global height datum, you can achieve this with a transformation (EPSG method 9616) adding a local constant reference height. If you need to model local terrain undulations, you can achieve this with a transformation using an offset matrix (EPSG method 9635), just as you can between the geoid and the ellipsoid.

- **Mean sea level (MSL):** MSL is a common variation of sea level that provides conceptual simplicity, ignoring local variations and changes over time in sea level. It can also be extrapolated to areas covered by land.

Height relative to MSL is useful for a variety of applications, such as those dealing with flooding risk, gravitational potential, and how thin the air is. MSL is commonly used for the heights of aircraft in flight.

- **Geoid:** The geoid, the equipotential surface closest to MSL, provides the most precise measurements of height in terms of gravitational pull, factoring in such things as climate and tectonic changes. The geoid can deviate from MSL by approximately 2 meters (plus or minus).

If an application is affected more by purely gravitational effects than by actual local sea level, you may want to use the geoid as the reference rather than MSL. To perform transformations between MSL, geoid, or ellipsoid, you can use EPSG method 9635 and the appropriate time-stamped offset matrix.

Because most non-ellipsoidal height references are irregular and undulating surfaces, transformations between them are more complicated than with ellipsoidal heights. One approach is to use an offset grid file to define the transformation. This approach is implemented in EPSG method 9635. The grid file has to be acquired (often available publicly from government websites). Moreover, because most such non-ellipsoidal height datums (including the geoid, sea level, and local terrain) change over time, the timestamp of an offset matrix may matter, even if not by much. (Of course, the same principle applies to ellipsoids as well, since they are not static in the long term. After all, they are intended to approximate the changing geoid, MSL, or terrain.)

Regarding performance and memory usage with EPSG method 9635, at runtime the grid must be loaded before the transformation of a dataset. This load operation temporarily increases the footprint in main memory and incurs one-time loading overhead. If an entire dataset is transformed, the overhead can be relatively insignificant; however, if frequent transformations are performed on single geometries, the cumulative overhead can become significant.

6.2.3.2 Ellipsoidal Height

Ellipsoidal height is measured from a point on the reference ellipsoid. The ellipsoid is a convenient and relatively faithful approximation of the Earth. Although using an ellipsoid is more complex than using a sphere to represent the Earth, using an ellipsoid

is, for most applications, simpler than using a geoid or local heights (although with some sacrifice in precision). Moreover, geoidal and sea-level heights are often not well suited for mathematical analysis, because the undulating and irregular shapes would make certain computations prohibitively complex and expensive.

GPS applications often assume ellipsoidal height as a reference and use it as the default. Because the ellipsoid is chosen to match the geoid (and similar sea level), ellipsoidal height tends not to deviate far from MSL height. For example, the geoid diverges from the NAD83 ellipsoid by only up to 50 meters. Other ellipsoids may be chosen to match a particular country even more closely.

Even if different parties use different ellipsoids, a WKT can conveniently describe such differences. A simple datum transformation can efficiently and accurately perform transformations between ellipsoids. Because no offset matrix is involved, no loading overhead is required. Thus, interoperability is simplified with ellipsoidal height, although future requirements or analysis might necessitate the use of MSL, a geoid, or other non-ellipsoidal height datums.

6.2.4 Geodetic MBRs

To create a query window for certain operations on geodetic data, use an MBR (minimum bounding rectangle) by specifying an `SDO_ETYPE` value of 1003 or 2003 (optimized rectangle) and an `SDO_INTERPRETATION` value of 3, as described in [Table 2–2](#) in [Section 2.2.4](#). A geodetic MBR can be used with the following operators: [SDO_FILTER](#), [SDO_RELATE](#) with the `ANYINTERACT` mask, [SDO_ANYINTERACT](#), and [SDO_WITHIN_DISTANCE](#).

[Example 6–1](#) requests the names of all cola markets that are likely to interact spatially with a geodetic MBR.

Example 6–1 Using a Geodetic MBR

```
SELECT c.name FROM cola_markets_cs c WHERE
  SDO_FILTER(c.shape,
    SDO_GEOMETRY(
      2003,
      8307,    -- SRID for WGS 84 longitude/latitude
      NULL,
      SDO_ELEM_INFO_ARRAY(1,1003,3),
      SDO_ORDINATE_ARRAY(6,5, 10,10))
  ) = 'TRUE';
```

[Example 6–1](#) produces the following output (assuming the data as defined in [Example 6–17](#) in [Section 6.13](#)):

```
NAME
-----
cola_c
cola_b
cola_d
```

The following considerations apply to the use of geodetic MBRs:

- Do not use a geodetic MBR with spatial objects stored in the database. Use it only to construct a query window.
- The lower-left Y coordinate (minY) must be less than the upper-right Y coordinate (maxY). If the lower-left X coordinate (minX) is greater than the upper-right X coordinate (maxX), the window is assumed to cross the date line meridian (that is, the meridian "opposite" the prime meridian, or both 180 and -180 longitude). For

example, an MBR of (-10,10, -100, 20) with longitude/latitude data goes three-fourths of the way around the Earth (crossing the date line meridian), and goes from latitude lines 10 to 20.

- When Spatial constructs the MBR internally for the query, lines along latitude lines are densified by adding points at one-degree intervals. This might affect results for objects within a few meters of the edge of the MBR (especially objects in the middle latitudes in both hemispheres).
- When an optimized rectangle spans more than 119 degrees in longitude, it is internally divided into three rectangles; and as a result, these three rectangles share an edge that is the common boundary between them. If you validate the geometry of such an optimized rectangle, error code 13351 is returned because the internal rectangles have a shared edge. You can use such an optimized rectangle for queries with only the following: [SDO_ANYINTERACT](#) operator, [SDO_RELATE](#) operator with the ANYINTERACT mask, or [SDO_GEOM.RELATE](#) function with the ANYINTERACT mask. (Any other queries on such an optimized rectangle may return incorrect results.)

The following additional examples show special or unusual cases, to illustrate how a geodetic MBR is interpreted with longitude/latitude data:

- (10,0, -110,20) crosses the date line meridian and goes most of the way around the world, and goes from the equator to latitude 20.
- (10,-90, 40,90) is a band from the South Pole to the North Pole between longitudes 10 and 40.
- (10,-90, 40,50) is a band from the South Pole to latitude 50 between longitudes 10 and 40.
- (-180,-10, 180,5) is a band that wraps the equator from 10 degrees south to 5 degrees north.
- (-180,-90, 180,90) is the whole Earth.
- (-180,-90, 180,50) is the whole Earth below latitude 50.
- (-180,50, 180,90) is the whole Earth above latitude 50.

6.2.5 Other Considerations and Requirements with Geodetic Data

The following geometries are not permitted if a geodetic coordinate system is used or if any transformation is being performed (even if the transformation is from one projected coordinate system to another projected coordinate system):

- Circles
- Circular arcs

Geodetic coordinate system support is provided only for geometries that consist of points or geodesics (lines on the ellipsoid). If you have geometries containing circles or circular arcs in a projected coordinate system, you can densify them using the [SDO_GEOM.SDO_ARC_DENSIFY](#) function (documented in [Chapter 24](#)) before transforming them to geodetic coordinates, and then perform Spatial operations on the resulting geometries.

The following size limits apply with geodetic data:

- No polygon element can have an area larger than or equal to one-half the surface of the Earth. Moreover, if the result of a union of two polygons is greater than one-half the surface of the Earth, the operation will not produce a correct result. For example, if A union B results in a polygon that is greater than one-half of the

area of the Earth, the operations A difference B, A intersection B, and A XOR B are not supported, and only a relate operation with the ANYINTERACT mask is supported between those two polygons.

- In a line, the distance between two adjacent coordinates cannot be greater than or equal to one-half the perimeter (a great circle) of the Earth.

If you need to work with larger elements, first break these elements into multiple smaller elements and work with them. For example, you cannot create a geometry representing the entire ocean surface of the Earth; however, you can create multiple geometries, each representing part of the overall ocean surface. To work with a line string that is greater than or equal to one-half the perimeter of the Earth, you can add one or more intermediate points on the line so that all adjacent coordinates are less than one-half the perimeter of the Earth.

Tolerance is specified as meters for geodetic layers. If you use tolerance values that are typical for non-geodetic data, these values are interpreted as meters for geodetic data. For example, if you specify a tolerance value of 0.05 for geodetic data, this is interpreted as precise to 5 centimeters. If this value is more precise than your applications need, performance may be affected because of the internal computational steps taken to implement the specified precision. (For more information about tolerance, see [Section 1.5.5](#).)

For geodetic layers, you must specify the dimensional extents in the index metadata as -180,180 for longitude and -90,90 for latitude. The following statement (from [Example 6-17](#) in [Section 6.13](#)) specifies these extents (with a 10-meter tolerance value in each dimension) for a geodetic data layer:

```
INSERT INTO user_sdo_geom_metadata
  (TABLE_NAME,
   COLUMN_NAME,
   DIMINFO,
   SRID)
VALUES (
  'cola_markets_cs',
  'shape',
  SDO_DIM_ARRAY(
    SDO_DIM_ELEMENT('Longitude', -180, 180, 10), -- 10 meters tolerance
    SDO_DIM_ELEMENT('Latitude', -90, 90, 10) -- 10 meters tolerance
  ),
  8307 -- SRID for 'Longitude / Latitude (WGS 84)' coordinate system
);
```

See [Section 6.10](#) for additional notes and restrictions relating to geodetic data.

6.3 Local Coordinate Support

Spatial provides a level of support for local coordinate systems. Local coordinate systems are often used in CAD systems, and they can also be used in local surveys where the relationship between the surveyed site and the rest of the world is not important.

Several local coordinate systems are predefined and included with Spatial in the SDO_COORD_REF_SYS table (described in [Section 6.7.9](#)). These supplied local coordinate systems, whose names start with *Non-Earth*, define non-Earth Cartesian coordinate systems based on different units of measurement (*Meter*, *Millimeter*, *Inch*, and so on).

In the current release, you cannot perform coordinate system transformation between local and Earth-based coordinate systems; and when transforming a geometry or layer of geometries between local coordinate systems, you can only to convert coordinates

in a local coordinate system from one unit of measurement to another (for example, inches to millimeters). However, you can perform all other Spatial operations (for example, using [SDO_RELATE](#), [SDO_WITHIN_DISTANCE](#), and other operators) with local coordinate systems.

6.4 EPSG Model and Spatial

The Oracle Spatial coordinate system support is based on, but is not always identical to, the European Petroleum Survey Group (EPSG) data model and dataset. These are described in detail at <http://www.epsg.org>, and the download for the EPSG geodetic parameter dataset includes a "Readme" that contains an entity-relationship (E-R) diagram. The approach taken by Oracle Spatial provides the benefits of standardization, expanded support, and flexibility:

- The EPSG model is a comprehensive and widely accepted standard for data representation, so users familiar with it can more easily understand Spatial storage and operations.
- Support is provided for more coordinate systems and their associated datums, ellipsoids, and projections. For example, some of the EPSG geographic and projected coordinate systems had no counterpart among coordinate systems supported for previous Spatial releases. Their addition results in an expanded set of supported coordinate systems.
- Data transformations are more flexible. Instead of there being only one possible Oracle-defined transformation path between a given source and target coordinate system, you can specify alternative paths to be used for a specific area of applicability (that is, use case) or as the systemwide default.

The rest of this section describes this flexibility.

For data transformations (that is, transforming data from one coordinate system to another), you can now control which transformation rules are to be applied. In previous releases, and in the current release by default, Spatial performs transformations based only on the specified source and target coordinate systems, using predetermined intermediate transformation steps. The assumption behind that default approach is that there is a single correct or preferable transformation chain.

By default, then, Spatial applies certain transformation methods for each supported transformation between specific pairs of source and target coordinate systems. For example, there are over 500 supported transformations from specific coordinate systems to the WGS 84 (longitude/latitude) coordinate system, which has the EPSG SRID value of 4326. As one example, for a transformation from SRID 4605 to SRID 4326, Spatial can use the transformation method with the `COORD_OP_ID` value 1445, as indicated in the `SDO_COORD_OPS` table (described in [Section 6.7.8](#)), which contains one row for each transformation operation between coordinate systems.

However, you can override the default transformation by specifying a different method (from the set of Oracle-supplied methods) for the transformation for any given source and target SRID combination. You can specify a transformation as the new systemwide default, or you can associate the transformation with a named use case that can be specified when transforming a layer of spatial geometries. (A **use case** is simply a name given to a usage scenario or area of applicability, such as *Project XYZ* or *Mike's Favorite Transformations*; there is no relationship between use cases and database users or schemas.)

To specify a transformation as either the systemwide default or associated with a use case, use the [SDO_CS.ADD_PREFERENCE_FOR_OP](#) procedure. To remove a

previously specified preference, use the [SDO_CS.REVOKE_PREFERENCE_FOR_OP](#) procedure.

When it performs a coordinate system transformation, Spatial follows these general steps to determine the specific transformation to use:

1. If a use case has been specified, the transformation associated with that use case is applied.
2. If no use case has been specified and if a user-defined systemwide transformation has been created for the specified source and target coordinate system pair, that transformation is applied.
3. If no use case has been specified and if no user-defined transformation exists for the specified source and target coordinate system pair, the behavior depends on whether or not EPSG rules have been created, such as by the [SDO_CS.CREATE_OBVIOUS_EPSG_RULES](#) procedure:
 - If the EPSG rules have been created and if an EPSG rule is defined for this transformation, the EPSG transformation is applied.
 - If the EPSG rules have not been created, or if they have been created but no EPSG rule is defined for this transformation, the Oracle Spatial default transformation is applied.

6.5 Three-Dimensional Coordinate Reference System Support

The Oracle Spatial support for three-dimensional coordinate reference systems complies with the EPSG model (described in [Section 6.4](#)), which provides the following types of coordinate reference systems:

- Geographic 2D
- Projected 2D
- Geographic 3D, which consists of Geographic 2D plus ellipsoidal height, with longitude, latitude, and height based on the same ellipsoid and datum
- Compound, which consists of either Geographic 2D plus gravity-related height or Projected 2D plus gravity-related height

Thus, there are two categories of three-dimensional coordinate reference systems: those based on ellipsoidal height (geographic 3D, described in [Section 6.5.1](#)) and those based on gravity-related height (compound, described in [Section 6.5.2](#)).

Three-dimensional computations are more accurate than their two-dimensional equivalents, particularly when they are chained: For example, datum transformations internally always are performed in three dimensions, regardless of the dimensionality of the source and target CRS and geometries. When two-dimensional geometries are involved, one or more of the following can occur:

1. When the input or output geometries and CRS are two-dimensional, the (unspecified) input height defaults to zero (above the ellipsoid, depending on the CRS) for any internal three-dimensional computations. This is a potential source of inaccuracy, unless the height was intended to be exactly zero. (Data can be two-dimensional because height values were originally either unavailable or not considered important; this is different from representing data in two dimensions because heights are known to be exactly zero.)
2. The transformation might then internally result in a non-zero height. Since the two-dimensional target CRS cannot accommodate the height value, the height value must be truncated, resulting in further inaccuracy.

3. If further transformations are chained, the repeated truncation of height values can result in increasing inaccuracies. Note that an inaccurate input height can affect not only the output height of a transformation, but also the longitude and latitude.

However, if the source and target CRS are three-dimensional, there is no repeated truncation of heights. Consequently, accuracy is increased, particularly for transformation chains.

For an introduction to support in Spatial for three-dimensional geometries, see [Section 1.11](#).

6.5.1 Geographic 3D Coordinate Reference Systems

A geographic three-dimensional coordinate reference system is based on longitude and latitude, plus ellipsoidal height. The **ellipsoidal height** is the height relative to a reference ellipsoid, which is an approximation of the real Earth. All three dimensions of the CRS are based on the same ellipsoid.

Using ellipsoidal heights enables Spatial to perform internal operations with great mathematical regularity and efficiency. Compound coordinate reference systems, on the other hand, require more complex transformations, often based on offset matrixes. Some of these matrixes have to be downloaded and configured. Furthermore, they might have a significant footprint, on disk and in main memory.

The supported geographic 3D coordinate reference systems are listed in the SDO_CRS_GEOGRAPHIC3D view, described in [Section 6.7.16](#).

6.5.2 Compound Coordinate Reference Systems

A compound three-dimensional coordinate reference system is based on a geographic or projected two-dimensional system, plus gravity-related height. **Gravity-related height** is the height as influenced by the Earth's gravitational force, where the base height (zero) is often an equipotential surface, and might be defined as above or below "sea level."

Gravity-related height is a more complex representation than ellipsoidal height, because of gravitational irregularities such as the following:

- Orthometric height

Orthometric height is also referred to as the height above the geoid. The geoid is an equipotential surface that most closely (but not exactly) matches mean sea level. An equipotential surface is a surface on which each point is at the same gravitational potential level. Such a surface tends to undulate slightly, because the Earth has regions of varying density. There are multiple equipotential surfaces, and these might not be parallel to each other due to the irregular density of the Earth.

- Height relative to mean sea level, to sea level at a specific location, or to a vertical network warped to fit multiple tidal stations (for example, NGVD 29)

Sea level is close to, but not identical to, the geoid. The sea level at a given location is often defined based on the "average sea level" at a specific port.

The supported compound coordinate reference systems are listed in the SDO_CRS_COMPOUND view, described in [Section 6.7.12](#).

You can create a customized compound coordinate reference system, which combines a horizontal CRS with a vertical CRS. (The *horizontal* CRS contains two dimensions, such as X and Y or longitude and latitude, and the *vertical* CRS contains the third

dimension, such as Z or height or altitude.) [Section 6.9.4](#) explains how to create a compound CRS.

6.5.3 Three-Dimensional Transformations

Spatial supports three-dimensional coordinate transformations for SDO_GEOMETRY objects directly, and indirectly for point clouds and TINs. (For example, a point cloud must be transformed to a table with an SDO_GEOMETRY column.) The supported transformations include the following:

- Three-dimensional datum transformations
- Transformations between ellipsoidal and gravity-related height

For three-dimensional datum transformations, the datum transformation between the two ellipsoids is essentially the same as for two-dimensional coordinate reference systems, except that the third dimension is considered instead of ignored. Because height values are not ignored, the accuracy of the results increases, especially for transformation chains.

For transformations between ellipsoidal and gravity-related height, computations are complicated by the fact that equipotential and other gravity-related surfaces tend to undulate, compared to any ellipsoid and to each other. Transformations might be based on higher-degree polynomial functions or bilinear interpolation. In either case, a significant parameter matrix is required to define the transformation.

For transforming between gravity-related and ellipsoidal height, the process usually involves a transformation, based on an offset matrix, between geoidal and ellipsoidal height. Depending on the source or target definition of the offset matrix, a common datum transformation might have to be appended or prefixed.

[Example 6-2](#) shows a three-dimensional datum transformation.

Example 6-2 Three-Dimensional Datum Transformation

```
set numwidth 9

CREATE TABLE source_geoms (
  mkt_id NUMBER PRIMARY KEY,
  name VARCHAR2(32),
  GEOMETRY SDO_GEOMETRY);

INSERT INTO source_geoms VALUES(
  1,
  'reference geom',
  SDO_GEOMETRY(
  3001,
  4985,
  SDO_POINT_TYPE(
    4.0,
    55.0,
    1.0),
  NULL,
  NULL));

INSERT INTO USER_SDO_GEOM_METADATA VALUES (
  'source_geoms',
  'GEOMETRY',
  SDO_DIM_ARRAY(
    SDO_DIM_ELEMENT('Longitude', -180, 180, 10),
    SDO_DIM_ELEMENT('Latitude', -90, 90, 10),
```

```
        SDO_DIM_ELEMENT('Height',    -1000,1000, 10)),
    4985);

commit;

-----

CALL SDO_CS.TRANSFORM_LAYER(
    'source_geoms',
    'GEOMETRY',
    'GEO_CS_4979',
    4979);

INSERT INTO USER_SDO_GEOM_METADATA VALUES (
    'GEO_CS_4979',
    'GEOMETRY',
    SDO_DIM_ARRAY(
        SDO_DIM_ELEMENT('Longitude', -180, 180, 10),
        SDO_DIM_ELEMENT('Latitude',   -90,  90, 10),
        SDO_DIM_ELEMENT('Height',     -1000,1000, 10)),
    4979);

set lines 210;

-----

CALL SDO_CS.TRANSFORM_LAYER(
    'GEO_CS_4979',
    'GEOMETRY',
    'source_geoms2',
    4985);

INSERT INTO USER_SDO_GEOM_METADATA VALUES (
    'source_geoms2',
    'GEOMETRY',
    SDO_DIM_ARRAY(
        SDO_DIM_ELEMENT('Longitude', -180, 180, 10),
        SDO_DIM_ELEMENT('Latitude',   -90,  90, 10),
        SDO_DIM_ELEMENT('Height',     -1000,1000, 10)),
    4985);

-----

DELETE FROM USER_SDO_GEOM_METADATA WHERE table_name = 'GEO_CS_4979';
DELETE FROM USER_SDO_GEOM_METADATA WHERE table_name = 'SOURCE_GEOMS';
DELETE FROM USER_SDO_GEOM_METADATA WHERE table_name = 'SOURCE_GEOMS2';

drop table GEO_CS_4979;
drop table source_geoms;
drop table source_geoms2;
```

As a result of the transformation in [Example 6-2](#), (4, 55, 1) is transformed to (4.0001539, 55.0000249, 4.218).

[Example 6-3](#) configures a transformation between geoidal and ellipsoidal height, using a Hawaii offset grid. Note that without the initial creation of a rule (using the [SDO_CS.CREATE_PREF_CONCATENATED_OP](#) procedure), the grid would not be used.

Example 6-3 Transformation Between Geoidal And Ellipsoidal Height

```

-- Create Sample operation:
insert into mdsys.sdo_coord_ops (
  COORD_OP_ID,
  COORD_OP_NAME,
  COORD_OP_TYPE,
  SOURCE_SRID,
  TARGET_SRID,
  COORD_TFM_VERSION,
  COORD_OP_VARIANT,
  COORD_OP_METHOD_ID,
  UOM_ID_SOURCE_OFFSETS,
  UOM_ID_TARGET_OFFSETS,
  INFORMATION_SOURCE,
  DATA_SOURCE,
  SHOW_OPERATION,
  IS_LEGACY,
  LEGACY_CODE,
  REVERSE_OP,
  IS_IMPLEMENTED_FORWARD,
  IS_IMPLEMENTED_REVERSE)
values (
  1000000005,
  'Test Bi-linear Interpolation',
  'CONVERSION',
  null,
  null,
  null,
  null,
  9635,
  null,
  null,
  'Oracle',
  'Oracle',
  1,
  'FALSE',
  null,
  1,
  1,
  1);

--Create sample parameters, pointing to the offset file
--(in this case reusing values from an existing operation):
insert into mdsys.sdo_coord_op_param_vals (
  coord_op_id,
  COORD_OP_METHOD_ID,
  PARAMETER_ID,
  PARAMETER_VALUE,
  PARAM_VALUE_FILE_REF,
  PARAM_VALUE_FILE,
  PARAM_VALUE_XML,
  UOM_ID) (
select
  1000000005,
  9635,
  8666,
  PARAMETER_VALUE,
  PARAM_VALUE_FILE_REF,
  PARAM_VALUE_FILE,
  PARAM_VALUE_XML,

```

```

        UOM_ID
    from
        mdsys.sdo_coord_op_param_vals
    where
        coord_op_id = 999998 and
        parameter_id = 8666);

--Create a rule to use this operation between SRIDs 7406 and 4359:
call sdo_cs.create_pref_concatenated_op(
    300,
    'CONCATENATED OPERATION',
    TFM_PLAN(SDO_TFM_CHAIN(7406, 1000000005, 4359)),
    NULL);

-- Now, actually perform the transformation:
set numformat 999999.999999999

-- Create the source table
CREATE TABLE source_geoms (
    mkt_id NUMBER PRIMARY KEY,
    name VARCHAR2(32),
    GEOMETRY SDO_GEOMETRY);

INSERT INTO source_geoms VALUES(
    1,
    'reference geom',
    SDO_GEOMETRY(
    3001,
    7406,
    SDO_POINT_TYPE(
        -161,
        18,
        0),
    NULL,
    NULL));

INSERT INTO USER_SDO_GEOM_METADATA VALUES (
    'source_geoms',
    'GEOMETRY',
    SDO_DIM_ARRAY(
        SDO_DIM_ELEMENT('Longitude', -180, 180, 10),
        SDO_DIM_ELEMENT('Latitude', -90, 90, 10),
        SDO_DIM_ELEMENT('Height', -100, 100, 10)),
    7406);

commit;

SELECT GEOMETRY "Source" FROM source_geoms;

-----

--Perform the transformation:
CALL SDO_CS.TRANSFORM_LAYER(
    'source_geoms',
    'GEOMETRY',
    'GEO_CS_4359',
    4359);

INSERT INTO USER_SDO_GEOM_METADATA VALUES (

```

```

'GEO_CS_4359',
'GEOMETRY',
SDO_DIM_ARRAY(
  SDO_DIM_ELEMENT('Longitude', -180, 180, 10),
  SDO_DIM_ELEMENT('Latitude', -90, 90, 10),
  SDO_DIM_ELEMENT('Height', -100, 100, 10)),
4359);

set lines 210;

SELECT GEOMETRY "Target" FROM GEO_CS_4359;

-----

--Transform back:
CALL SDO_CS.TRANSFORM_LAYER(
  'GEO_CS_4359',
  'GEOMETRY',
  'source_geoms2',
  7406);

INSERT INTO USER_SDO_GEOM_METADATA VALUES (
  'source_geoms2',
  'GEOMETRY',
  SDO_DIM_ARRAY(
    SDO_DIM_ELEMENT('Longitude', -180, 180, 10),
    SDO_DIM_ELEMENT('Latitude', -90, 90, 10),
    SDO_DIM_ELEMENT('Height', -100, 100, 10)),
  7406);

SELECT GEOMETRY "Source2" FROM source_geoms2;

-----

--Clean up (regarding the transformation):
DELETE FROM USER_SDO_GEOM_METADATA WHERE table_name = 'GEO_CS_4359';
DELETE FROM USER_SDO_GEOM_METADATA WHERE table_name = 'SOURCE_GEOMS';
DELETE FROM USER_SDO_GEOM_METADATA WHERE table_name = 'SOURCE_GEOMS2';

drop table GEO_CS_4359;
drop table source_geoms;
drop table source_geoms2;

--Clean up (regarding the rule):
CALL sdo_cs.delete_op(300);

delete from mdsys.sdo_coord_op_param_vals where coord_op_id = 1000000005;

delete from mdsys.sdo_coord_ops where coord_op_id = 1000000005;

COMMIT;

```

With the configuration in [Example 6-3](#):

- Without the rule, (-161.00000000, 18.00000000, .00000000) is transformed to (-161.00127699, 18.00043360, 62.03196364), based simply on a datum transformation.
- With the rule, (-161.00000000, 18.00000000, .00000000) is transformed to (-161.00000000, 18.00000000, 6.33070000).

6.5.4 Cross-Dimensionality Transformations

You cannot directly perform a cross-dimensionality transformation (for example, from a two-dimensional geometry to a three-dimensional geometry) using the `SDO_CS.TRANSFORM` function or the `SDO_CS.TRANSFORM_LAYER` procedure.

However, you can use the `SDO_CS.MAKE_3D` function to convert a two-dimensional geometry to a three-dimensional geometry, or the `SDO_CS.MAKE_2D` function to convert a three-dimensional geometry to a two-dimensional geometry; and you can use the resulting geometry to perform a transformation into a geometry with the desired number of dimensions.

For example, transforming a two-dimensional geometry into a three-dimensional geometry involves using the `SDO_CS.MAKE_3D` function. This function does not itself perform any coordinate transformation, but simply adds a height value and sets the target SRID. You must choose an appropriate target SRID, which should be the three-dimensional equivalent of the source SRID. For example, three-dimensional WGS84 (4327) is the equivalent of two-dimensional WGS84 (4326). If necessary, modify height values of vertices in the returned geometry.

There are many options for how to use the `SDO_CS.MAKE_3D` function, but the simplest is the following:

1. Transform from the two-dimensional source SRID to two-dimensional WGS84 (4326).
2. Call `SDO_CS.MAKE_3D` to convert the geometry to three-dimensional WGS84 (4327)
3. Transform from three-dimensional WGS84 (4327) to the three-dimensional target SRID.

Example 6-4 transforms a two-dimensional point from SRID 27700 to two-dimensional SRID 4326, converts the result of the transformation to a three-dimensional point with SRID 4327, and transforms the converted point to three-dimensional SRID 4327.

Example 6-4 Cross-Dimensionality Transformation

```
SELECT
  SDO_CS.TRANSFORM(
    SDO_CS.MAKE_3D(
      SDO_CS.TRANSFORM(
        SDO_GEOMETRY(
          2001,
          27700,
          SDO_POINT_TYPE(577274.984, 69740.4923, NULL),
          NULL,
          NULL),
          4326),
      height => 0,
      target_srid => 4327),
    4327) "27700 > 4326 > 4327 > 4327"
FROM DUAL;

27700 > 4326 > 4327 > 4327(SDO_GTYPE, SDO_SRID, SDO_POINT(X, Y, Z), SDO_ELEM_INF
-----
SDO_GEOMETRY(3001, 4327, SDO_POINT_TYPE(.498364058, 50.5006366, 0), NULL, NULL)
```

6.5.5 3D Equivalent for WGS 84?

There are two possible answers to the question *What is 3D equivalent for the WGS 84 coordinate system?* (that is, 2D Oracle SRID 8308 or EPSG SRID 4326):

- 4979 (in many or most cases), or
- It depends on what you mean by *height* (for example, above ground level, above or below sea level, or something else).

There are many different height datums. Height can be relative to:

- The ellipsoid, which requires the use of a coordinate system of type GEOGRAPHIC3d, for which SRID values 4327, 43229, and 4979 are predefined in Oracle Spatial.
- A non-ellipsoidal height datum, which requires the use of a coordinate system of type COMPOUND, for which a custom SRID must usually be defined. The non-ellipsoidal height may be specified in relation to the geoid, to some local or mean sea level (or a network of local sea levels), or to some other definition of *height* (such as above ground surface).

To define a compound coordinate system (see [Section 6.5.2, "Compound Coordinate Reference Systems"](#)) based on the two dimensions of the WGS 84 coordinate system, you must first select a predefined or custom vertical coordinate reference system (see [Section 6.9.3, "Creating a Vertical CRS"](#)). To find the available vertical coordinate reference systems, enter the following statement:

```
SELECT srid, COORD_REF_SYS_NAME from sdo_coord_ref_sys
WHERE COORD_REF_SYS_KIND = 'VERTICAL' order by srid;
```

```

SRID COORD_REF_SYS_NAME
-----
3855 EGM2008 geoid height
3886 Fao 1979 height
4440 NZVD2009 height
4458 Dunedin-Bluff 1960 height
5600 NGPF height
5601 IGN 1966 height
5602 Moorea SAU 1981 height
. . .
5795 Guadeloupe 1951 height
5796 Lagos 1955 height
5797 AIOC95 height
5798 EGM84 geoid height
5799 DVR90 height

```

123 rows selected.

After selecting a vertical coordinate reference system, create the compound SRID by entering a statement in the following form:

```
INSERT INTO sdo_coord_ref_system (
  SRID,
  COORD_REF_SYS_NAME,
  COORD_REF_SYS_KIND,
  COORD_SYS_ID,
  DATUM_ID,
  GEOG CRS_DATUM_ID,
  SOURCE_GEOG_SRID,
  PROJECTION_CONV_ID,
  CMPD_HORIZ_SRID,
  CMPD_VERT_SRID,
  INFORMATION_SOURCE,
  DATA_SOURCE,
  IS_LEGACY,
  LEGACY_CODE,
```

```

LEGACY_WKTEXT,
LEGACY_CS_BOUNDS,
IS_VALID,
SUPPORTS_SDO_GEOMETRY)
values (
  custom-SRID,
  'custom-name',
  'COMPOUND',
  NULL,
  NULL,
  6326,
  NULL,
  NULL,
  NULL,
  4326,
  vertical-SRID,
  'custom-information-source',
  'custom-data-source',
  'FALSE',
  NULL,
  NULL,
  NULL,
  'TRUE',
  'TRUE');

```

You can check the definition, based on the generated WKT, by entering a statement in the following form:

```
SELECT wktext3d FROM cs_srs WHERE srid = custom-SRID;
```

```
WKTEXT3D
```

```

-----
COMPD_CS[
  "NTF (Paris) + NGF IGN69",
  GEOGCS["NTF (Paris)",
    DATUM["Nouvelle Triangulation Francaise (Paris)",
      SPHEROID[
        "Clarke 1880 (IGN)",
        6378249.2,
        293.4660212936293951,
        AUTHORITY["EPSG", "7011"]],
      TOWGS84[-168.0, -60.0, 320.0, 0.0, 0.0, 0.0, 0.0],
      AUTHORITY["EPSG", "6807"]],
    PRIMEM["Paris", 2.337229, AUTHORITY["EPSG", "8903"]],
    UNIT["grad", 0.015707963267949, AUTHORITY["EPSG", "9105"]],
    AXIS["Lat", NORTH],
    AXIS["Long", EAST],
    AUTHORITY["EPSG", "4807"]],
  VERT_CS["NGF IGN69",
    VERT_DATUM["Nivellement general de la France - IGN69", 2005,
      AUTHORITY["EPSG", "5119"]],
    UNIT["metre", 1.0, AUTHORITY["EPSG", "9001"]],
    AXIS["H", UP],
    AUTHORITY["EPSG", "5720"]],
  AUTHORITY["EPSG", "7400"]]

```

When transforming between different height datums, you might use a VERTCON matrix. For example, between the WGS 84 ellipsoid and geoid, there is an offset matrix that allows height transformation. For more information, see the following:

- [Example 6–3, "Transformation Between Geoidal And Ellipsoidal Height"](#) in [Section 6.5.3, "Three-Dimensional Transformations"](#)

- [Section 6.9.6, "Creating a Transformation Operation"](#)
- [Section 6.9.7, "Using British Grid Transformation OSTN02/OSGM02 \(EPSG Method 9633\)"](#)

6.6 TFM_PLAN Object Type

The object type TFM_PLAN is used by several SDO_CS package subprograms to specify a transformation plan. For example, to create a concatenated operation that consists of two operations specified by a parameter of type TFM_PLAN, use the [SDO_CS.CREATE_CONCATENATED_OP](#) procedure.

Oracle Spatial defines the object type TFM_PLAN as:

```
CREATE TYPE tfm_plan AS OBJECT (
  THE_PLAN SDO_TFM_CHAIN);
```

The SDO_TFM_CHAIN type is defined as VARRAY(1048576) OF NUMBER.

Within the SDO_TFM_CHAIN array:

- The first element specifies the SRID of the source coordinate system.
- Each pair of elements after the first element specifies an operation ID and the SRID of a target coordinate system.

6.7 Coordinate Systems Data Structures

The coordinate systems functions and procedures use information provided in the tables and views supplied with Oracle Spatial. The tables and views are part of the MDSYS schema; however, public synonyms are defined, so you do not need to specify MDSYS before the table or view name. The definitions and data in these tables and views are based on the EPSG data model and dataset, as explained in [Section 6.4](#).

The coordinate system tables fit into several general categories:

- Coordinate system general information: SDO_COORD_SYS, SDO_COORD_REF_SYS
- Elements or aspects of a coordinate system definition: SDO_DATUMS, SDO_ELLIPSOIDS, SDO_PRIME_MERIDIANS
- Datum transformation support: SDO_COORD_OPS, SDO_COORD_OP_METHODS, SDO_COORD_OP_PARAM_USE, SDO_COORD_OP_PARAM_VALS, SDO_COORD_OP_PARAMS, SDO_COORD_OP_PATHS, SDO_PREFERRED_OPS_SYSTEM, SDO_PREFERRED_OPS_USER
- Others related to coordinate system definition: SDO_COORD_AXES, SDO_COORD_AXIS_NAMES, SDO_UNITS_OF_MEASURE

Several views are provided that are identical to or subsets of coordinate system tables:

- SDO_COORD_REF_SYSTEM, which contains the same columns as the SDO_COORD_REF_SYS table. Use the SDO_COORD_REF_SYSTEM view instead of the COORD_REF_SYS table for any insert, update, or delete operations.
- Subsets of SDO_DATUMS, selected according to the value in the DATUM_TYPE column: SDO_DATUM_ENGINEERING, SDO_DATUM_GEODETTIC, SDO_DATUM_VERTICAL.
- Subsets of SDO_COORD_REF_SYS, selected according to the value in the COORD_REF_SYS_KIND column: SDO_CRS_COMPOUND, SDO_CRS_

ENGINEERING, SDO_CRS_GEOCENTRIC, SDO_CRS_GEOGRAPHIC2D, SDO_CRS_GEOGRAPHIC3D, SDO_CRS_PROJECTED, SDO_CRS_VERTICAL.

Most of the rest of this section explains these tables and views, in alphabetical order. (Many column descriptions are adapted or taken from EPSG descriptions.) [Section 6.7.28](#) describes relationships among the tables and views, and it lists EPSG table names and their corresponding Oracle Spatial names. [Section 6.7.29](#) describes how to find information about EPSG-based coordinate systems, and it provides several examples.

In addition to the tables and views in this section, Spatial provides several legacy tables whose definitions and data match those of certain Spatial system tables used in previous releases. [Section 6.8](#) describes the legacy tables.

Note: You should not modify or delete any Oracle-supplied information in any of the tables or views that are used for coordinate system support.

If you want to create a user-defined coordinate system, see [Section 6.9](#).

6.7.1 SDO_COORD_AXES Table

The SDO_COORD_AXES table contains one row for each coordinate system axis definition. This table contains the columns shown in [Table 6–1](#).

Table 6–1 SDO_COORD_AXES Table

Column Name	Data Type	Description
COORD_SYS_ID	NUMBER(10)	ID number of the coordinate system to which this axis applies.
COORD_AXIS_NAME_ID	NUMBER(10)	ID number of a coordinate system axis name. Matches a value in the COORD_AXIS_NAME_ID column of the SDO_COORD_AXIS_NAMES table (described in Section 6.7.2). Example: 9901 (for Geodetic latitude)
COORD_AXIS_ORIENTATION	VARCHAR2(24)	The direction of orientation for the coordinate system axis. Example: east
COORD_AXIS_ABBREVIATION	VARCHAR2(24)	The abbreviation for the coordinate system axis orientation. Example: E
UOM_ID	NUMBER(10)	ID number of the unit of measurement associated with the axis. Matches a value in the UOM_ID column of the SDO_UNITS_OF_MEASURE table (described in Section 6.7.27).
ORDER	NUMBER(5)	Position of this axis within the coordinate system (1, 2, or 3).

6.7.2 SDO_COORD_AXIS_NAMES Table

The SDO_COORD_AXIS_NAMES table contains one row for each axis that can be used in a coordinate system definition. This table contains the columns shown in [Table 6–2](#).

Table 6–2 SDO_COORD_AXIS_NAMES Table

Column Name	Data Type	Description
COORD_AXIS_NAME_ID	NUMBER(10)	ID number of the coordinate axis name. Example: 9926
COORD_AXIS_NAME	VARCHAR2(80)	Name of the coordinate axis. Example: Spherical latitude

6.7.3 SDO_COORD_OP_METHODS Table

The SDO_COORD_OP_METHODS table contains one row for each coordinate systems transformation method. This table contains the columns shown in [Table 6–3](#).

Table 6–3 SDO_COORD_OP_METHODS Table

Column Name	Data Type	Description
COORD_OP_METHOD_ID	NUMBER(10)	ID number of the coordinate system transformation method. Example: 9613
COORD_OP_METHOD_NAME	VARCHAR2(50)	Name of the method. Example: NADCON
LEGACY_NAME	VARCHAR2(50)	Name for this transformation method in the legacy WKT strings. This name might differ syntactically from the name used by EPSG.
REVERSE_OP	NUMBER(1)	Contains 1 if reversal of the transformation (from the current target coordinate system to the source coordinate system) can be achieved by reversing the sign of each parameter value; contains 0 if a separate operation must be defined for reversal of the transformation.
INFORMATION_SOURCE	VARCHAR2(254)	Origin of this information. Example: US Coast and geodetic Survey - http://www.ngs.noaa.gov
DATA_SOURCE	VARCHAR2(40)	Organization providing the data for this record. Example: EPSG
IS_IMPLEMENTED_FORWARD	NUMBER(1)	Contains 1 if the forward operation is implemented; contains 0 if the forward operation is not implemented.
IS_IMPLEMENTED_REVERSE	NUMBER(1)	Contains 1 if the reverse operation is implemented; contains 0 if the reverse operation is not implemented.

6.7.4 SDO_COORD_OP_PARAM_USE Table

The SDO_COORD_OP_PARAM_USE table contains one row for each combination of transformation method and transformation operation parameter that is available for use. This table contains the columns shown in [Table 6–4](#).

Table 6–4 SDO_COORD_OP_PARAM_USE Table

Column Name	Data Type	Description
COORD_OP_METHOD_ID	NUMBER(10)	ID number of the coordinate system transformation method. Matches a value in the COORD_OP_METHOD_ID column of the COORD_OP_METHODS table (described in Section 6.7.3).

Table 6–4 (Cont.) SDO_COORD_OP_PARAM_USE Table

Column Name	Data Type	Description
PARAMETER_ID	NUMBER(10)	ID number of the parameter for transformation operations. Matches a value in the PARAMETER_ID column of the SDO_COORD_OP_PARAMS table (described in Section 6.7.6).
LEGACY_PARAM_NAME	VARCHAR2(80)	Open GeoSpatial Consortium (OGC) name for the parameter.
SORT_ORDER	NUMBER(5)	A number indicating the position of this parameter in the sequence of parameters for this method. Example: 2 for the second parameter
PARAM_SIGN_REVERSAL	VARCHAR2(3)	Yes if reversal of the transformation (from the current target coordinate system to the source coordinate system) can be achieved by reversing the sign of each parameter value; No if a separate operation must be defined for reversal of the transformation.

6.7.5 SDO_COORD_OP_PARAM_VALS Table

The SDO_COORD_OP_PARAM_VALS table contains information about parameter values for each coordinate system transformation method. This table contains the columns shown in [Table 6–5](#).

Table 6–5 SDO_COORD_OP_PARAM_VALS Table

Column Name	Data Type	Description
COORD_OP_ID	NUMBER(10)	ID number of the coordinate transformation operation. Matches a value in the COORD_OP_ID column of the SDO_COORD_OPS table (described in Section 6.7.8).
COORD_OP_METHOD_ID	NUMBER(10)	Coordinate operation method ID. Must match a COORD_OP_METHOD_ID value in the SDO_COORD_OP_METHODS table (see Section 6.7.3).
PARAMETER_ID	NUMBER(10)	ID number of the parameter for transformation operations. Matches a value in the PARAMETER_ID column of the SDO_COORD_OP_PARAMS table (described in Section 6.7.6).
PARAMETER_VALUE	FLOAT(49)	Value of the parameter for this operation.
PARAM_VALUE_FILE_REF	VARCHAR2(254)	Name of the file (as specified in the original EPSG database) containing the value data, if a single value for the parameter is not sufficient.
PARAM_VALUE_FILE	CLOB	The ASCII content of the file specified in the PARAM_VALUE_FILE_REF column. Used only for grid file parameters (for NADCON, NTv2, and height transformations "Geographic3D to Geographic2D+GravityRelatedHeight").
PARAM_VALUE_XML	XMLTYPE	An XML representation of the content of the file specified in the PARAM_VALUE_FILE_REF column. (Optional, and currently only used for documentation.)

Table 6–5 (Cont.) SDO_COORD_OP_PARAM_VALS Table

Column Name	Data Type	Description
UOM_ID	NUMBER(10)	ID number of the unit of measurement associated with the operation. Matches a value in the UOM_ID column of the SDO_UNITS_OF_MEASURE table (described in Section 6.7.27).

6.7.6 SDO_COORD_OP_PARAMS Table

The SDO_COORD_OP_PARAMS table contains one row for each available parameter for transformation operations. This table contains the columns shown in [Table 6–6](#).

Table 6–6 SDO_COORD_OP_PARAMS Table

Column Name	Data Type	Description
PARAMETER_ID	NUMBER(10)	ID number of the parameter. Example: 8608
PARAMETER_NAME	VARCHAR2(80)	Name of the operation. Example: X-axis rotation
INFORMATION_SOURCE	VARCHAR2(254)	Origin of this information. Example: EPSG guidance note number 7.
DATA_SOURCE	VARCHAR2(40)	Organization providing the data for this record. Example: EPSG

6.7.7 SDO_COORD_OP_PATHS Table

The SDO_COORD_OP_PATHS table contains one row for each atomic step in a concatenated operation. This table contains the columns shown in [Table 6–7](#).

Table 6–7 SDO_COORD_OP_PATHS Table

Column Name	Data Type	Description
CONCAT_OPERATION_ID	NUMBER(10)	ID number of the concatenation operation. Must match a COORD_OP_ID value in the SDO_COORD_OPS table (described in Section 6.7.8) for which the COORD_OP_TYPE value is CONCATENATION.
SINGLE_OPERATION_ID	NUMBER(10)	ID number of the single coordinate operation for this step (atomic operation) in a concatenated operation. Must match a COORD_OP_ID value in the SDO_COORD_OPS table (described in Section 6.7.8).
SINGLE_OP_SOURCE_ID	NUMBER(10)	ID number of source coordinate reference system for the single coordinate operation for this step. Must match an SRID value in the SDO_COORD_REF_SYS table (described in Section 6.7.9).
SINGLE_OP_TARGET_ID	NUMBER(10)	ID number of target coordinate reference system for the single coordinate operation for this step. Must match an SRID value in the SDO_COORD_REF_SYS table (described in Section 6.7.9).
OP_PATH_STEP	NUMBER(5)	Sequence number of this step (atomic operation) within this concatenated operation.

6.7.8 SDO_COORD_OPS Table

The SDO_COORD_OPS table contains one row for each transformation operation between coordinate systems. This table contains the columns shown in [Table 6–8](#).

Table 6–8 SDO_COORD_OPS Table

Column Name	Data Type	Description
COORD_OP_ID	NUMBER(10)	ID number of the coordinate transformation operation. Example: 101
COORD_OP_NAME	VARCHAR2(80)	Name of the operation. Example: ED50 to WGS 84 (14)
COORD_OP_TYPE	VARCHAR2(24)	Type of operation. One of the following: CONCATENATED OPERATION, CONVERSION, or TRANSFORMATION
SOURCE_SRID	NUMBER(10)	SRID of the coordinate system from which to perform the transformation. Example: 4230
TARGET_SRID	NUMBER(10)	SRID of the coordinate system into which to perform the transformation. Example: 4326
COORD_TFM_VERSION	VARCHAR2(24)	Name assigned by EPSG to the coordinate transformation. Example: 5Nat-NSea90
COORD_OP_VARIANT	NUMBER(5)	A variant of the more generic method specified in COORD_OP_METHOD_ID. Example: 14
COORD_OP_METHOD_ID	NUMBER(10)	Coordinate operation method ID. Must match a COORD_OP_METHOD_ID value in the SDO_COORD_OP_METHODS table (see Section 6.7.3). Several operations can use a method. Example: 9617
UOM_ID_SOURCE_OFFSETS	NUMBER(10)	ID number of the unit of measurement for offsets in the source coordinate system. Matches a value in the UOM_ID column of the SDO_UNITS_OF_MEASURE table (described in Section 6.7.27).
UOM_ID_TARGET_OFFSETS	NUMBER(10)	ID number of the unit of measurement for offsets in the target coordinate system. Matches a value in the UOM_ID column of the SDO_UNITS_OF_MEASURE table (described in Section 6.7.27).
INFORMATION_SOURCE	VARCHAR2(254)	Origin of this information. Example: Institut de Geomatica; Barcelona
DATA_SOURCE	VARCHAR2(40)	Organization providing the data for this record. Example: EPSG
SHOW_OPERATION	NUMBER(3)	(Not currently used.)
IS_LEGACY	VARCHAR2(5)	TRUE if the operation was included in Oracle Spatial before release 10.2; FALSE if the operation is new in Oracle Spatial release 10.2.
LEGACY_CODE	NUMBER(10)	For any EPSG coordinate transformation operation that has a semantically identical legacy (in Oracle Spatial before release 10.2) counterpart, the COORD_OP_ID value of the legacy coordinate transformation operation.
REVERSE_OP	NUMBER(1)	Contains 1 if reversal of the transformation (from the current target coordinate system to the source coordinate system) is defined as achievable by reversing the sign of each parameter value; contains 0 if a separate operation must be defined for reversal of the transformation. If REVERSE_OP contains 1, the operations that are actually implemented are indicated by the values for IS_IMPLEMENTED_FORWARD and IS_IMPLEMENTED_REVERSE.

Table 6–8 (Cont.) SDO_COORD_OPS Table

Column Name	Data Type	Description
IS_IMPLEMENTED_FORWARD	NUMBER(1)	Contains 1 if the forward operation is implemented; contains 0 if the forward operation is not implemented.
IS_IMPLEMENTED_REVERSE	NUMBER(1)	Contains 1 if the reverse operation is implemented; contains 0 if the reverse operation is not implemented.

6.7.9 SDO_COORD_REF_SYS Table

The SDO_COORD_REF_SYS table contains one row for each coordinate reference system. This table contains the columns shown in [Table 6–9](#). (The SDO_COORD_REF_SYS table is roughly patterned after the EPSG Coordinate Reference System table.)

Note: If you need to perform an insert, update, or delete operation, you *must* perform it on the SDO_COORD_REF_SYSTEM view, which contains the same columns as the SDO_COORD_REF_SYS table. The SDO_COORD_REF_SYSTEM view is described in [Section 6.7.10](#).

Table 6–9 SDO_COORD_REF_SYS Table

Column Name	Data Type	Description
SRID	NUMBER(10)	ID number of the coordinate reference system. Example: 8307
COORD_REF_SYS_NAME	VARCHAR2(80)	Name of the coordinate reference system. Example: Longitude / Latitude (WGS 84)
COORD_REF_SYS_KIND	VARCHAR2(24)	Category for the coordinate system. Example: GEOGRAPHIC2D
COORD_SYS_ID	NUMBER(10)	ID number of the coordinate system used for the coordinate reference system. Must match a COORD_SYS_ID value in the SDO_COORD_SYS table (see Section 6.7.11).
DATUM_ID	NUMBER(10)	ID number of the datum used for the coordinate reference system. Null for a projected coordinate system. For a geodetic coordinate system, must match a DATUM_ID value in the SDO_DATUMS table (see Section 6.7.22). Example: 10115
GEOG_CRS_DATUM_ID	NUMBER(10)	ID number of the datum used for the coordinate reference system. For a projected coordinate system, must match the DATUM_ID value (in the SDO_DATUMS table, described in Section 6.7.22) of the geodetic coordinate system on which the projected coordinate system is based. For a geodetic coordinate system, must match the DATUM_ID value. Example: 10115
SOURCE_GEOG_SRID	NUMBER(10)	For a projected coordinate reference system, the ID number for the associated geodetic coordinate system.
PROJECTION_CONV_ID	NUMBER(10)	For a projected coordinate reference system, the COORD_OP_ID value of the conversion operation used to convert the projected coordinated system to and from the source geographic coordinate system.

Table 6–9 (Cont.) SDO_COORD_REF_SYS Table

Column Name	Data Type	Description
CMPD_HORIZ_SRID	NUMBER(10)	(EPSG-assigned value; not used by Oracle Spatial. The EPSG description is: "For compound CRS only, the code of the horizontal component of the Compound CRS.")
CMPD_VERT_SRID	NUMBER(10)	(EPSG-assigned value; not used by Oracle Spatial. The EPSG description is: "For compound CRS only, the code of the vertical component of the Compound CRS.")
INFORMATION_SOURCE	VARCHAR2(254)	Provider of the definition for the coordinate system (Oracle for all rows supplied by Oracle).
DATA_SOURCE	VARCHAR2(40)	Organization that supplied the data for this record (if not Oracle).
IS_LEGACY	VARCHAR2(5)	TRUE if the coordinate system definition was included in Oracle Spatial before release 10.2; FALSE if the coordinate system definition is new in Oracle Spatial release 10.2.
LEGACY_CODE	NUMBER(10)	For any EPSG coordinate reference system that has a semantically identical legacy (in Oracle Spatial before release 10.2) counterpart, the SRID value of the legacy coordinate system.
LEGACY_WKTEXT	VARCHAR2(2046)	If IS_LEGACY is TRUE, contains the well-known text description of the coordinate system. Example: GEOGCS ["Longitude / Latitude (WGS 84)", DATUM ["WGS 84", SPHEROID ["WGS 84", 6378137, 298.257223563]], PRIMEM ["Greenwich", 0.000000], UNIT ["Decimal Degree", 0.01745329251994330]]
LEGACY_CS_BOUNDS	SDO_GEOMETRY	For a legacy coordinate system, the dimensional boundary (if any).
IS_VALID	VARCHAR2(5)	TRUE if the EPSG record for the coordinate reference system is completely defined; FALSE if the EPSG record for the coordinate reference system is not completely defined.
SUPPORTS_SDO_GEOMETRY	VARCHAR2(5)	TRUE if the COORD_REF_SYS_KIND column contains ENGINEERING, GEOGRAPHIC2D, or PROJECTED CRS; FALSE if the COORD_REF_SYS_KIND column contains any other value.

See also the information about the following views that are defined based on the value of the COORD_REF_SYS_KIND column:

- SDO_CRS_COMPOUND (Section 6.7.12)
- SDO_CRS_ENGINEERING (Section 6.7.13)
- SDO_CRS_GEOCENTRIC (Section 6.7.14)
- SDO_CRS_GEOGRAPHIC2D (Section 6.7.15)
- SDO_CRS_GEOGRAPHIC3D (Section 6.7.16)
- SDO_CRS_PROJECTED (Section 6.7.17)
- SDO_CRS_VERTICAL (Section 6.7.18)

6.7.10 SDO_COORD_REF_SYSTEM View

The SDO_COORD_REF_SYSTEM view contains the same columns as the SDO_COORD_REF_SYS table, which is described in [Section 6.7.9](#). However, the SDO_COORD_REF_SYSTEM view has a trigger defined on it, so that any insert, update, or delete operations performed on the view cause all relevant Spatial system tables to have the appropriate operations performed on them.

Therefore, if you need to perform an insert, update, or delete operation, you *must* perform it on the SDO_COORD_REF_SYSTEM view, *not* the SDO_COORD_REF_SYS table.

6.7.11 SDO_COORD_SYS Table

The SDO_COORD_SYS table contains rows with information about coordinate systems. This table contains the columns shown in [Table 6–10](#). (The SDO_COORD_SYS table is roughly patterned after the EPSG Coordinate System table, where a coordinate system is described as "a pair of reusable axes.")

Table 6–10 SDO_COORD_SYS Table

Column Name	Data Type	Description
COORD_SYS_ID	NUMBER(10)	ID number of the coordinate system. Example: 6405
COORD_SYS_NAME	VARCHAR2(254)	Name of the coordinate system. Example: Ellipsoidal 2D CS. Axes: latitude, longitude. Orientations: north, east. UoM: dec deg
COORD_SYS_TYPE	VARCHAR2(24)	Type of coordinate system. Example: ellipsoidal
DIMENSION	NUMBER(5)	Number of dimensions represented by the coordinate system.
INFORMATION_SOURCE	VARCHAR2(254)	Origin of this information.
DATA_SOURCE	VARCHAR2(50)	Organization providing the data for this record.

6.7.12 SDO_CRS_COMPOUND View

The SDO_CRS_COMPOUND view contains selected information from the SDO_COORD_REF_SYS table (described in [Section 6.7.9](#)) where the COORD_REF_SYS_KIND column value is COMPOUND. (For an explanation of compound coordinate reference systems, see [Section 6.5.2](#).) This view contains the columns shown in [Table 6–11](#).

Table 6–11 SDO_CRS_COMPOUND View

Column Name	Data Type	Description
SRID	NUMBER(10)	ID number of the coordinate reference system.
COORD_REF_SYS_NAME	VARCHAR2(80)	Name of the coordinate reference system.
CMPD_HORIZ_SRID	NUMBER(10)	(EPSG-assigned value; not used by Oracle Spatial. The EPSG description is: "For compound CRS only, the code of the horizontal component of the Compound CRS.")

Table 6–11 (Cont.) SDO_CRS_COMPOUND View

Column Name	Data Type	Description
CMPD_VERT_SRID	NUMBER(10)	(EPSG-assigned value; not used by Oracle Spatial. The EPSG description is: "For compound CRS only, the code of the vertical component of the Compound CRS.")
INFORMATION_SOURCE	VARCHAR2(254)	Provider of the definition for the coordinate system (Oracle for all rows supplied by Oracle).
DATA_SOURCE	VARCHAR2(40)	Organization that supplied the data for this record (if not Oracle).

6.7.13 SDO_CRS_ENGINEERING View

The SDO_CRS_ENGINEERING view contains selected information from the SDO_COORD_REF_SYS table (described in [Section 6.7.9](#)) where the COORD_REF_SYS_KIND column value is ENGINEERING. This view contains the columns shown in [Table 6–12](#).

Table 6–12 SDO_CRS_ENGINEERING View

Column Name	Data Type	Description
SRID	NUMBER(10)	ID number of the coordinate reference system.
COORD_REF_SYS_NAME	VARCHAR2(80)	Name of the coordinate reference system.
COORD_SYS_ID	NUMBER(10)	ID number of the coordinate system used for the coordinate reference system. Must match a COORD_SYS_ID value in the SDO_COORD_SYS table (see Section 6.7.11).
DATUM_ID	NUMBER(10)	ID number of the datum used for the coordinate reference system. Must match a DATUM_ID value in the SDO_DATUMS table (see Section 6.7.22).
INFORMATION_SOURCE	VARCHAR2(254)	Provider of the definition for the coordinate system (Oracle for all rows supplied by Oracle).
DATA_SOURCE	VARCHAR2(40)	Organization that supplied the data for this record (if not Oracle).

6.7.14 SDO_CRS_GEOCENTRIC View

The SDO_CRS_GEOCENTRIC view contains selected information from the SDO_COORD_REF_SYS table (described in [Section 6.7.9](#)) where the COORD_REF_SYS_KIND column value is GEOCENTRIC. This view contains the columns shown in [Table 6–13](#).

Table 6–13 SDO_CRS_GEOCENTRIC View

Column Name	Data Type	Description
SRID	NUMBER(10)	ID number of the coordinate reference system.
COORD_REF_SYS_NAME	VARCHAR2(80)	Name of the coordinate reference system.
COORD_SYS_ID	NUMBER(10)	ID number of the coordinate system used for the coordinate reference system. Must match a COORD_SYS_ID value in the SDO_COORD_SYS table (see Section 6.7.11).

Table 6–13 (Cont.) SDO_CRS_GEOCENTRIC View

Column Name	Data Type	Description
DATUM_ID	NUMBER(10)	ID number of the datum used for the coordinate reference system. Must match a DATUM_ID value in the SDO_DATUMS table (see Section 6.7.22).
INFORMATION_SOURCE	VARCHAR2(254)	Provider of the definition for the coordinate system (Oracle for all rows supplied by Oracle).
DATA_SOURCE	VARCHAR2(40)	Organization that supplied the data for this record (if not Oracle).

6.7.15 SDO_CRS_GEOGRAPHIC2D View

The SDO_CRS_GEOGRAPHIC2D view contains selected information from the SDO_COORD_REF_SYS table (described in [Section 6.7.9](#)) where the COORD_REF_SYS_KIND column value is GEOGRAPHIC2D. This view contains the columns shown in [Table 6–14](#).

Table 6–14 SDO_CRS_GEOGRAPHIC2D View

Column Name	Data Type	Description
SRID	NUMBER(10)	ID number of the coordinate reference system.
COORD_REF_SYS_NAME	VARCHAR2(80)	Name of the coordinate reference system.
COORD_SYS_ID	NUMBER(10)	ID number of the coordinate system used for the coordinate reference system. Must match a COORD_SYS_ID value in the SDO_COORD_SYS table (see Section 6.7.11).
DATUM_ID	NUMBER(10)	ID number of the datum used for the coordinate reference system. Must match a DATUM_ID value in the SDO_DATUMS table (see Section 6.7.22).
INFORMATION_SOURCE	VARCHAR2(254)	Provider of the definition for the coordinate system (Oracle for all rows supplied by Oracle).
DATA_SOURCE	VARCHAR2(40)	Organization that supplied the data for this record (if not Oracle).

6.7.16 SDO_CRS_GEOGRAPHIC3D View

The SDO_CRS_GEOGRAPHIC3D view contains selected information from the SDO_COORD_REF_SYS table (described in [Section 6.7.9](#)) where the COORD_REF_SYS_KIND column value is GEOGRAPHIC3D. (For an explanation of geographic 3D coordinate reference systems, see [Section 6.5.1](#).) This view contains the columns shown in [Table 6–15](#).

Table 6–15 SDO_CRS_GEOGRAPHIC3D View

Column Name	Data Type	Description
SRID	NUMBER(10)	ID number of the coordinate reference system.
COORD_REF_SYS_NAME	VARCHAR2(80)	Name of the coordinate reference system.
COORD_SYS_ID	NUMBER(10)	ID number of the coordinate system used for the coordinate reference system. Must match a COORD_SYS_ID value in the SDO_COORD_SYS table (see Section 6.7.11).

Table 6–15 (Cont.) SDO_CRS_GEOGRAPHIC3D View

Column Name	Data Type	Description
DATUM_ID	NUMBER(10)	ID number of the datum used for the coordinate reference system. Must match a DATUM_ID value in the SDO_DATUMS table (see Section 6.7.22).
INFORMATION_SOURCE	VARCHAR2(254)	Provider of the definition for the coordinate system (Oracle for all rows supplied by Oracle).
DATA_SOURCE	VARCHAR2(40)	Organization that supplied the data for this record (if not Oracle).

6.7.17 SDO_CRS_PROJECTED View

The SDO_CRS_PROJECTED view contains selected information from the SDO_COORD_REF_SYS table (described in [Section 6.7.9](#)) where the COORD_REF_SYS_KIND column value is PROJECTED. This view contains the columns shown in [Table 6–16](#).

Table 6–16 SDO_CRS_PROJECTED View

Column Name	Data Type	Description
SRID	NUMBER(10)	ID number of the coordinate reference system.
COORD_REF_SYS_NAME	VARCHAR2(80)	Name of the coordinate reference system.
COORD_SYS_ID	NUMBER(10)	ID number of the coordinate system used for the coordinate reference system. Must match a COORD_SYS_ID value in the SDO_COORD_SYS table (see Section 6.7.11).
SOURCE_GEOG_SRID	NUMBER(10)	ID number for the associated geodetic coordinate system.
PROJECTION_CONV_ID	NUMBER(10)	COORD_OP_ID value of the conversion operation used to convert the projected coordinated system to and from the source geographic coordinate system.
INFORMATION_SOURCE	VARCHAR2(254)	Provider of the definition for the coordinate system (Oracle for all rows supplied by Oracle).
DATA_SOURCE	VARCHAR2(40)	Organization that supplied the data for this record (if not Oracle).

6.7.18 SDO_CRS_VERTICAL View

The SDO_CRS_VERTICAL view contains selected information from the SDO_COORD_REF_SYS table (described in [Section 6.7.9](#)) where the COORD_REF_SYS_KIND column value is VERTICAL. This view contains the columns shown in [Table 6–17](#).

Table 6–17 SDO_CRS_VERTICAL View

Column Name	Data Type	Description
SRID	NUMBER(10)	ID number of the coordinate reference system.
COORD_REF_SYS_NAME	VARCHAR2(80)	Name of the coordinate reference system.

Table 6–17 (Cont.) SDO_CRS_VERTICAL View

Column Name	Data Type	Description
COORD_SYS_ID	NUMBER(10)	ID number of the coordinate system used for the coordinate reference system. Must match a COORD_SYS_ID value in the SDO_COORD_SYS table (see Section 6.7.11).
DATUM_ID	NUMBER(10)	ID number of the datum used for the coordinate reference system. Must match a DATUM_ID value in the SDO_DATUMS table (see Section 6.7.22).
INFORMATION_SOURCE	VARCHAR2(254)	Provider of the definition for the coordinate system (Oracle for all rows supplied by Oracle).
DATA_SOURCE	VARCHAR2(40)	Organization that supplied the data for this record (if not Oracle).

6.7.19 SDO_DATUM_ENGINEERING View

The SDO_DATUM_ENGINEERING view contains selected information from the SDO_DATUMS table (described in [Section 6.7.22](#)) where the DATUM_TYPE column value is ENGINEERING. This view contains the columns shown in [Table 6–18](#).

Table 6–18 SDO_DATUM_ENGINEERING View

Column Name	Data Type	Description
DATUM_ID	NUMBER(10)	ID number of the datum.
DATUM_NAME	VARCHAR2(80)	Name of the datum.
ELLIPSOID_ID	NUMBER(10)	ID number of the ellipsoid used in the datum definition. Must match an ELLIPSOID_ID value in the SDO_ELLIPSOIDS table (see Section 6.7.23). Example: 8045
PRIME_MERIDIAN_ID	NUMBER(10)	ID number of the prime meridian used in the datum definition. Must match a PRIME_MERIDIAN_ID value in the SDO_PRIME_MERIDIANS table (see Section 6.7.26). Example: 8950
INFORMATION_SOURCE	VARCHAR2(254)	Provider of the definition of the datum. Example: Ordnance Survey of Great Britain.
DATA_SOURCE	VARCHAR2(40)	Organization that supplied the data for this record (if not Oracle).
SHIFT_X	NUMBER	Number of meters to shift the ellipsoid center relative to the center of the WGS 84 ellipsoid on the x-axis.
SHIFT_Y	NUMBER	Number of meters to shift the ellipsoid center relative to the center of the WGS 84 ellipsoid on the y-axis.
SHIFT_Z	NUMBER	Number of meters to shift the ellipsoid center relative to the center of the WGS 84 ellipsoid on the z-axis.
ROTATE_X	NUMBER	Number of arc-seconds of rotation about the x-axis.
ROTATE_Y	NUMBER	Number of arc-seconds of rotation about the y-axis.
ROTATE_Z	NUMBER	Number of arc-seconds of rotation about the z-axis.
SCALE_ADJUST	NUMBER	A value to be used in adjusting the X, Y, and Z values after any shifting and rotation, according to the formula: $1.0 + (\text{SCALE_ADJUST} * 10^{-6})$

6.7.20 SDO_DATUM_GEODETTIC View

The SDO_DATUM_GEODETTIC view contains selected information from the SDO_DATUMS table (described in [Section 6.7.22](#)) where the DATUM_TYPE column value is GEODETTIC. This view contains the columns shown in [Table 6–19](#).

Table 6–19 SDO_DATUM_GEODETTIC View

Column Name	Data Type	Description
DATUM_ID	NUMBER(10)	ID number of the datum.
DATUM_NAME	VARCHAR2(80)	Name of the datum.
ELLIPSOID_ID	NUMBER(10)	ID number of the ellipsoid used in the datum definition. Must match an ELLIPSOID_ID value in the SDO_ELLIPSOIDS table (see Section 6.7.23). Example: 8045
PRIME_MERIDIAN_ID	NUMBER(10)	ID number of the prime meridian used in the datum definition. Must match a PRIME_MERIDIAN_ID value in the SDO_PRIME_MERIDIANS table (see Section 6.7.26). Example: 8950
INFORMATION_SOURCE	VARCHAR2(254)	Provider of the definition of the datum. Example: Ordnance Survey of Great Britain.
DATA_SOURCE	VARCHAR2(40)	Organization that supplied the data for this record (if not Oracle).
SHIFT_X	NUMBER	Number of meters to shift the ellipsoid center relative to the center of the WGS 84 ellipsoid on the x-axis.
SHIFT_Y	NUMBER	Number of meters to shift the ellipsoid center relative to the center of the WGS 84 ellipsoid on the y-axis.
SHIFT_Z	NUMBER	Number of meters to shift the ellipsoid center relative to the center of the WGS 84 ellipsoid on the z-axis.
ROTATE_X	NUMBER	Number of arc-seconds of rotation about the x-axis.
ROTATE_Y	NUMBER	Number of arc-seconds of rotation about the y-axis.
ROTATE_Z	NUMBER	Number of arc-seconds of rotation about the z-axis.
SCALE_ADJUST	NUMBER	A value to be used in adjusting the X, Y, and Z values after any shifting and rotation, according to the formula: $1.0 + (\text{SCALE_ADJUST} * 10^{-6})$

6.7.21 SDO_DATUM_VERTICAL View

The SDO_DATUM_VERTICAL view contains selected information from the SDO_DATUMS table (described in [Section 6.7.22](#)) where the DATUM_TYPE column value is VERTICAL. This view contains the columns shown in [Table 6–20](#).

Table 6–20 SDO_DATUM_VERTICAL View

Column Name	Data Type	Description
DATUM_ID	NUMBER(10)	ID number of the datum.
DATUM_NAME	VARCHAR2(80)	Name of the datum.

Table 6–20 (Cont.) SDO_DATUM_VERTICAL View

Column Name	Data Type	Description
ELLIPSOID_ID	NUMBER(10)	ID number of the ellipsoid used in the datum definition. Must match an ELLIPSOID_ID value in the SDO_ELLIPSOIDS table (see Section 6.7.23). Example: 8045
PRIME_MERIDIAN_ID	NUMBER(10)	ID number of the prime meridian used in the datum definition. Must match a PRIME_MERIDIAN_ID value in the SDO_PRIME_MERIDIANS table (see Section 6.7.26). Example: 8950
INFORMATION_SOURCE	VARCHAR2(254)	Provider of the definition of the datum. Example: Ordnance Survey of Great Britain.
DATA_SOURCE	VARCHAR2(40)	Organization that supplied the data for this record (if not Oracle).
SHIFT_X	NUMBER	Number of meters to shift the ellipsoid center relative to the center of the WGS 84 ellipsoid on the x-axis.
SHIFT_Y	NUMBER	Number of meters to shift the ellipsoid center relative to the center of the WGS 84 ellipsoid on the y-axis.
SHIFT_Z	NUMBER	Number of meters to shift the ellipsoid center relative to the center of the WGS 84 ellipsoid on the z-axis.
ROTATE_X	NUMBER	Number of arc-seconds of rotation about the x-axis.
ROTATE_Y	NUMBER	Number of arc-seconds of rotation about the y-axis.
ROTATE_Z	NUMBER	Number of arc-seconds of rotation about the z-axis.
SCALE_ADJUST	NUMBER	A value to be used in adjusting the X, Y, and Z values after any shifting and rotation, according to the formula: $1.0 + (\text{SCALE_ADJUST} * 10^{-6})$

6.7.22 SDO_DATUMS Table

The SDO_DATUMS table contains one row for each datum. This table contains the columns shown in [Table 6–21](#).

Table 6–21 SDO_DATUMS Table

Column Name	Data Type	Description
DATUM_ID	NUMBER(10)	ID number of the datum. Example: 10115
DATUM_NAME	VARCHAR2(80)	Name of the datum. Example: WGS 84
DATUM_TYPE	VARCHAR2(24)	Type of the datum. Example: GEODETIC
ELLIPSOID_ID	NUMBER(10)	ID number of the ellipsoid used in the datum definition. Must match an ELLIPSOID_ID value in the SDO_ELLIPSOIDS table (see Section 6.7.23). Example: 8045
PRIME_MERIDIAN_ID	NUMBER(10)	ID number of the prime meridian used in the datum definition. Must match a PRIME_MERIDIAN_ID value in the SDO_PRIME_MERIDIANS table (see Section 6.7.26). Example: 8950
INFORMATION_SOURCE	VARCHAR2(254)	Provider of the definition of the datum. Example: Ordnance Survey of Great Britain.

Table 6–21 (Cont.) SDO_DATUMS Table

Column Name	Data Type	Description
DATA_SOURCE	VARCHAR2(40)	Organization that supplied the data for this record (if not Oracle). Example: EPSG
SHIFT_X	NUMBER	Number of meters to shift the ellipsoid center relative to the center of the WGS 84 ellipsoid on the x-axis.
SHIFT_Y	NUMBER	Number of meters to shift the ellipsoid center relative to the center of the WGS 84 ellipsoid on the y-axis.
SHIFT_Z	NUMBER	Number of meters to shift the ellipsoid center relative to the center of the WGS 84 ellipsoid on the z-axis.
ROTATE_X	NUMBER	Number of arc-seconds of rotation about the x-axis.
ROTATE_Y	NUMBER	Number of arc-seconds of rotation about the y-axis.
ROTATE_Z	NUMBER	Number of arc-seconds of rotation about the z-axis.
SCALE_ADJUST	NUMBER	A value to be used in adjusting the X, Y, and Z values after any shifting and rotation, according to the formula: $1.0 + (\text{SCALE_ADJUST} * 10^{-6})$
IS_LEGACY	VARCHAR2(5)	TRUE if the datum definition was included in Oracle Spatial before release 10.2; FALSE if the datum definition is new in Oracle Spatial release 10.2.
LEGACY_CODE	NUMBER(10)	For any EPSG datum that has a semantically identical legacy (in Oracle Spatial before release 10.2) counterpart, the DATUM_ID value of the legacy datum.

See also the information about the following views that are defined based on the value of the DATUM_TYPE column: SDO_DATUM_ENGINEERING (Section 6.7.19), SDO_DATUM_GEODETTIC (Section 6.7.20), and SDO_DATUM_VERTICAL (Section 6.7.21).

6.7.23 SDO_ELLIPSOIDS Table

The SDO_ELLIPSOIDS table contains one row for each ellipsoid. This table contains the columns shown in Table 6–22.

Table 6–22 SDO_ELLIPSOIDS Table

Column Name	Data Type	Description
ELLIPSOID_ID	NUMBER	ID number of the ellipsoid (spheroid). Example: 8045
ELLIPSOID_NAME	VARCHAR2(80)	Name of the ellipsoid. Example: WGS 84
SEMI_MAJOR_AXIS	NUMBER	Radius in meters along the semi-major axis (one-half of the long axis of the ellipsoid).
UOM_ID	NUMBER	ID number of the unit of measurement for the ellipsoid. Matches a value in the UOM_ID column of the SDO_UNITS_OF_MEASURE table (described in Section 6.7.27). Example: 9001
INV_FLATTENING	NUMBER	Inverse flattening of the ellipsoid. That is, $1/f$, where $f = (a-b)/a$, and a is the semi-major axis and b is the semi-minor axis.

Table 6–22 (Cont.) SDO_ELLIPSOIDS Table

Column Name	Data Type	Description
SEMI_MINOR_AXIS	NUMBER	Radius in meters along the semi-minor axis (one-half of the short axis of the ellipsoid).
INFORMATION_SOURCE	VARCHAR2(254)	Origin of this information. Example: Kort og Matrikelstyrelsen (KMS), Copenhagen.
DATA_SOURCE	VARCHAR2(40)	Organization that supplied the data for this record (if not Oracle). Example: EPSG
IS_LEGACY	VARCHAR2(5)	TRUE if the ellipsoid definition was included in Oracle Spatial before release 10.2; FALSE if the ellipsoid definition is new in Oracle Spatial release 10.2.
LEGACY_CODE	NUMBER	For any EPSG ellipsoid that has a semantically identical legacy (in Oracle Spatial before release 10.2) counterpart, the ELLIPSOID_ID value of the legacy ellipsoid.

6.7.24 SDO_PREFERRED_OPS_SYSTEM Table

The SDO_PREFERRED_OPS_SYSTEM table contains one row for each specification of the user-defined default preferred coordinate transformation operation for a source and target SRID combination. If you insert a row into the SDO_PREFERRED_OPS_SYSTEM table, you are overriding the Oracle default operation for transformations between the specified source and target coordinate systems. The [SDO_CS.CREATE_OBVIOUS_EPSG_RULES](#) procedure inserts many rows into this table. The [SDO_CS.DELETE_ALL_EPSG_RULES](#) procedure deletes all rows from this table if the use_case parameter is null. This table contains the columns shown in [Table 6–23](#).

Table 6–23 SDO_PREFERRED_OPS_SYSTEM Table

Column Name	Data Type	Description
SOURCE_SRID	NUMBER(10)	ID number of the coordinate system (spatial reference system) from which to perform coordinate transformation, using the operation specified by COORD_OP_ID as the default preferred method for transforming to the specified target SRID.
COORD_OP_ID	NUMBER(10)	ID number of the coordinate transformation operation. Matches a value in the COORD_OP_ID column of the SDO_COORD_OPS table (described in Section 6.7.8).
TARGET_SRID	NUMBER(10)	ID number of coordinate system (spatial reference system) into which to perform coordinate transformation using the operation specified by COORD_OP_ID.

6.7.25 SDO_PREFERRED_OPS_USER Table

The SDO_PREFERRED_OPS_USER table contains one row for each specification of a user-defined source and target SRID and coordinate transformation operation. If you insert a row into the SDO_PREFERRED_OPS_USER table, you create a custom transformation between the source and target coordinate systems, and you can specify the name (the USE_CASE column value) of the transformation operation as the use_case parameter value with several SDO_CS functions and procedures. If you specify a use case with the [SDO_CS.DELETE_ALL_EPSG_RULES](#) procedure, rows associated

with that use case are deleted from this table. This table contains the columns shown in [Table 6–24](#).

Table 6–24 SDO_PREFERRED_OPS_USER Table

Column Name	Data Type	Description
USE_CASE	VARCHAR2(32)	Name of this specification of a source and target SRID and coordinate transformation operation.
SOURCE_SRID	NUMBER(10)	ID number of the coordinate system (spatial reference system) from which to perform the transformation.
COORD_OP_ID	NUMBER(10)	ID number of the coordinate transformation operation. Matches a value in the COORD_OP_ID column of the SDO_COORD_OPS table (described in Section 6.7.8).
TARGET_SRID	NUMBER(10)	ID number of the coordinate system (spatial reference system) into which to perform the transformation.

6.7.26 SDO_PRIME_MERIDIANS Table

The SDO_PRIME_MERIDIANS table contains one row for each prime meridian that can be used in a datum specification. This table contains the columns shown in [Table 6–25](#).

Table 6–25 SDO_PRIME_MERIDIANS Table

Column Name	Data Type	Description
PRIME_MERIDIAN_ID	NUMBER(10)	ID number of the prime meridian. Example: 8907
PRIME_MERIDIAN_NAME	VARCHAR2(80)	Name of the prime meridian. Example: Bern
GREENWICH_LONGITUDE	FLOAT(49)	Longitude of the prime meridian as an offset from the Greenwich meridian. Example: 7.26225
UOM_ID	NUMBER(10)	ID number of the unit of measurement for the prime meridian. Matches a value in the UOM_ID column of the SDO_UNITS_OF_MEASURE table (described in Section 6.7.27). Example: 9110 for sexagesimal degree
INFORMATION_SOURCE	VARCHAR2(254)	Origin of this information. Example: Bundesamt fur Landestopographie
DATA_SOURCE	VARCHAR2(254)	Organization that supplied the data for this record (if not Oracle). Example: EPSG

6.7.27 SDO_UNITS_OF_MEASURE Table

The SDO_UNITS_OF_MEASURE table contains one row for each unit of measurement. This table contains the columns shown in [Table 6–26](#).

Table 6–26 SDO_UNITS_OF_MEASURE Table

Column Name	Data Type	Description
UOM_ID	NUMBER(10)	ID number of the unit of measurement. Example: 10032
UNIT_OF_MEAS_NAME	VARCHAR2(2083)	Name of the unit of measurement; can also be a URL or URI. Example: Meter

Table 6–26 (Cont.) SDO_UNITS_OF_MEASURE Table

Column Name	Data Type	Description
SHORT_NAME	VARCHAR2(80)	Short name (if any) of the unit of measurement. Example: METER
UNIT_OF_MEAS_ TYPE	VARCHAR2(50)	Type of measure for which the unit is used: angle for angle unit, area for area unit, length for distance unit, scale for scale unit, or volume for volume unit.
TARGET_UOM_ID	NUMBER(10)	ID number of a target unit of measurement. Corresponds to the TARGET_UOM_CODE column in the EPSG Unit of Measure table, which has the following description: "Other UOM of the same type into which the current UOM can be converted using the formula (POSC); POSC factors A and D always equal zero for EPSG supplied units of measure."
FACTOR_B	NUMBER	Corresponds to the FACTOR_B column in the EPSG Unit of Measure table, which has the following description: "A quantity in the target UOM (y) is obtained from a quantity in the current UOM (x) through the conversion: $y = (B/C).x$ " In a user-defined unit of measurement, FACTOR_B is usually the number of square meters or meters equal to one of the unit. For information about user-defined units, see Section 2.10.1 .
FACTOR_C	NUMBER	Corresponds to the FACTOR_C column in the EPSG Unit of Measure table. For FACTOR_C in a user-defined unit of measurement, see Section 2.10.1 .
INFORMATION_ SOURCE	VARCHAR2(254)	Origin of this information. Example: ISO 1000.
DATA_SOURCE	VARCHAR2(40)	Organization providing the data for this record. Example: EPSG
IS_LEGACY	VARCHAR2(5)	TRUE if the unit of measurement definition was included in Oracle Spatial before release 10.2; FALSE if the unit of measurement definition is new in Oracle Spatial release 10.2.
LEGACY_CODE	NUMBER(10)	For any EPSG unit of measure that has a semantically identical legacy (in Oracle Spatial before release 10.2) counterpart, the UOM_ID value of the legacy unit of measure.

6.7.28 Relationships Among Coordinate System Tables and Views

Because the definitions in Spatial system tables and views are based on the EPSG data model and dataset, the EPSG entity-relationship (E-R) diagram provides a good overview of the relationships among the Spatial coordinate system data structures. The EPSG E-R diagram is included in the following document:

<http://www.epsg.org/CurrentDB.html>

However, Oracle Spatial does not use the following from the EPSG E-R diagram:

- Area of Use (yellow box in the upper center of the diagram)
- Deprecation, Alias, and others represented by pink boxes in the lower right corner of the diagram

In addition, Spatial changes the names of some tables to conform to its own naming conventions, and it does not use some tables, as shown in [Table 6–27](#)

Table 6–27 *EPSG Table Names and Oracle Spatial Names*

EPSG Name	Oracle Name
Coordinate System	SDO_COORD_SYS
Coordinate Axis	SDO_COORD_AXES
Coordinate Reference System	SDO_COORD_REF_SYSTEM
Area Of Use	(Not used)
Datum	SDO_DATUMS
Prime Meridian	SDO_PRIME_MERIDIANS
Ellipsoid	SDO_ELLIPSOIDS
Unit Of Measure	SDO_UNITS_OF_MEASURE
Coordinate Operation	SDO_COORD_OPS
Coord. Operation Parameter ValueCoord	SDO_COORD_OP_PARAM_VALS
Operation Parameter UsageCoord.	SDO_COORD_OP_PARAM_USE
Operation Parameter	SDO_COORD_OP_PARAMS
Coordinate Operation Path	SDO_COORD_OP_PATHS
Coordinate Operation Method	SDO_COORD_OP_METHODS
Change	(Not used)
Deprecation	(Not used)
Supersession	(Not used)
Naming System	(Not used)
Alias	(Not used)
Any Entity	(Not used)

6.7.29 Finding Information About EPSG-Based Coordinate Systems

This section explains how to query the Spatial coordinate systems data structures for information about geodetic and projected EPSG-based coordinate systems.

6.7.29.1 Geodetic Coordinate Systems

A human-readable summary of a CRS is the WKT string. For example:

```
SQL> select wktext from cs_srs where srid = 4326;
```

```
WKTEXT
```

```
-----
GEOGCS [ "WGS 84", DATUM [ "World Geodetic System 1984 (EPSG ID 6326)", SPHEROID
["WGS 84 (EPSG ID 7030)", 6378137, 298.257223563]], PRIMEM [ "Greenwich", 0.0000
00 ], UNIT [ "Decimal Degree", 0.01745329251994328]]
```

EPSG WKTs have been automatically generated by Spatial, for backward compatibility. Note that EPSG WKTs also contain numeric ID values (such as EPSG ID 6326 in the preceding example) for convenience. However, for more detailed information you should access the EPSG data stored in the coordinate systems data

structures. The following example returns information about the ellipsoid, datum shift, rotation, and scale adjustment for SRID 4123:

```
SQL> select
  ell.semi_major_axis,
  ell.inv_flattening,
  ell.semi_minor_axis,
  ell.uom_id,
  dat.shift_x,
  dat.shift_y,
  dat.shift_z,
  dat.rotate_x,
  dat.rotate_y,
  dat.rotate_z,
  dat.scale_adjust
from
  sdo_coord_ref_system crs,
  sdo_datums dat,
  sdo_ellipsoids ell
where
  crs.srid = 4123 and
  dat.datum_id = crs.datum_id and
  ell.ellipsoid_id = dat.ellipsoid_id;
```

SEMI_MAJOR_AXIS	INV_FLATTENING	SEMI_MINOR_AXIS	UOM_ID	SHIFT_X	SHIFT_Y
SHIFT_Z	ROTATE_X	ROTATE_Y	ROTATE_Z	SCALE_ADJUST	
6378388	297	6356911.95	9001	-90.7	-106.1
-119.2	4.09	.218	-1.05	1.37	

In the preceding example, the UOM_ID represents the unit of measure for SEMI_MAJOR_AXIS (a) and SEMI_MINOR_AXIS (b). INV_FLATTENING is $a / (a - b)$ and has no associated unit. Shifts are in meters, rotation angles are given in arc seconds, and scale adjustment in parts per million.

To interpret the UOM_ID, you can query the units table, as shown in the following example:

```
SQL> select UNIT_OF_MEAS_NAME from sdo_units_of_measure where UOM_ID = 9001;
```

```
UNIT_OF_MEAS_NAME
-----
metre
```

Conversion factors for units of length are given relative to meters, as shown in the following example:

```
SQL> select UNIT_OF_MEAS_NAME, FACTOR_B/FACTOR_C from sdo_units_of_measure where
UOM_ID = 9002;
```

```
UNIT_OF_MEAS_NAME
-----
FACTOR_B/FACTOR_C
-----
foot
.3048
```

Conversion factors for units of angle are given relative to radians, as shown in the following example:

```
SQL> select UNIT_OF_MEAS_NAME, FACTOR_B/FACTOR_C from sdo_units_of_measure where
UOM_ID = 9102;
```

```
UNIT_OF_MEAS_NAME
-----
FACTOR_B/FACTOR_C
-----
degree
      .017453293
```

6.7.29.2 Projected Coordinate Systems

As mentioned in [Section 6.7.29.1](#), the WKT is a human-readable summary of a CRS, but the actual EPSG data is stored in the Spatial coordinate systems data structures. The following example shows the WKT string for a projected coordinate system:

```
SQL> select wktext from cs_srs where srid = 32040;
```

```
WKTEXT
-----
PROJCS["NAD27 / Texas South Central", GEOGCS [ "NAD27", DATUM ["North American D
atum 1927 (EPSG ID 6267)", SPHEROID ["Clarke 1866 (EPSG ID 7008)", 6378206.4, 29
4.978698213905820761610537123195175418]], PRIMEM [ "Greenwich", 0.000000 ], UNIT
 ["Decimal Degree", 0.01745329251994328]], PROJECTION ["Texas CS27 South Central
zone (EPSG OP 14204)"], PARAMETER ["Latitude_Of_Origin", 27.833333333333333333
33333333333333333333], PARAMETER ["Central_Meridian", -98.999999999999999999
999999999999987], PARAMETER ["Standard_Parallel_1", 28.3833333333333333333333
3333333333333333], PARAMETER ["Standard_Parallel_2", 30.2833333333333333333333
3333333333333333], PARAMETER ["False_Easting", 2000000], PARAMETER ["False_Northing",
0], UNIT ["U.S. Foot", .3048006096012192024384048768097536195072]]
```

To determine the base geographic CRS for a projected CRS, you can query the SDO_COORD_REF_SYSTEM table, as in the following example:

```
SQL> select SOURCE_GEOG_SRID from sdo_coord_ref_system where srid = 32040;
```

```
SOURCE_GEOG_SRID
-----
      4267
```

The following example returns the projection method for the projected CRS 32040:

```
SQL> select
  m.coord_op_method_name
from
  sdo_coord_ref_sys crs,
  sdo_coord_ops ops,
  sdo_coord_op_methods m
where
  crs.srid = 32040 and
  ops.coord_op_id = crs.projection_conv_id and
  m.coord_op_method_id = ops.coord_op_method_id;
```

```
COORD_OP_METHOD_NAME
-----
Lambert Conic Conformal (2SP)
```

The following example returns the projection parameters for the projected CRS 32040:

```
SQL> select
  params.parameter_name || ' = ' ||
  vals.parameter_value || ' ' ||
```



```

    uom.unit_of_meas_name "Projection parameters"
from
    sdo_coord_ref_sys crs,
    sdo_coord_op_param_vals vals,
    sdo_units_of_measure uom,
    sdo_coord_op_params params
where
    crs.srid = 32040 and
    vals.coord_op_id = crs.projection_conv_id and
    uom.uom_id = vals.uom_id and
    params.parameter_id = vals.parameter_id;

```

Projection parameters

```

-----
Latitude of false origin = 27.5 sexagesimal DMS
Longitude of false origin = -99 sexagesimal DMS
Latitude of 1st standard parallel = 28.23 sexagesimal DMS
Latitude of 2nd standard parallel = 30.17 sexagesimal DMS
Easting at false origin = 2000000 US survey foot
Northing at false origin = 0 US survey foot

```

The following example is essentially the same query as the preceding example, but it also converts the values to the base unit:

```

SQL> select
    params.parameter_name || ' = ' ||
    vals.parameter_value || ' ' ||
    uom.unit_of_meas_name || ' = ' ||
    sdo_cs.transform_to_base_unit(vals.parameter_value, vals.uom_id) || ' ' ||
    decode(
        uom.unit_of_meas_type,
        'area', 'square meters',
        'angle', 'radians',
        'length', 'meters',
        'scale', '', '') "Projection parameters"
from
    sdo_coord_ref_sys crs,
    sdo_coord_op_param_vals vals,
    sdo_units_of_measure uom,
    sdo_coord_op_params params
where
    crs.srid = 32040 and
    vals.coord_op_id = crs.projection_conv_id and
    uom.uom_id = vals.uom_id and
    params.parameter_id = vals.parameter_id;

```

Projection parameters

```

-----
-----
-----
Latitude of false origin = 27.5 sexagesimal DMS =
.485783308471754564814814814814814815 radians
Longitude of false origin = -99 sexagesimal DMS = -1.7278759594743845 radians
Latitude of 1st standard parallel = 28.23 sexagesimal DMS =
.495382619357723367592592592592592593 radians
Latitude of 2nd standard parallel = 30.17 sexagesimal DMS =
.528543875145615595370370370370370371 radians
Easting at false origin = 2000000 US survey foot =
609601.219202438404876809753619507239014 meters
Northing at false origin = 0 US survey foot = 0 meters

```

The following example returns the projection unit of measure for the projected CRS 32040. (The projection unit might be different from the length unit used for the projection parameters.)

```
SQL> select
  axes.coord_axis_abbreviation || ': ' ||
  uom.unit_of_meas_name "Projection units"
from
  sdo_coord_ref_sys crs,
  sdo_coord_axes axes,
  sdo_units_of_measure uom
where
  crs.srid = 32040 and
  axes.coord_sys_id = crs.coord_sys_id and
  uom.uom_id = axes.uom_id;
```

Projection units

```
-----
X: US survey foot
Y: US survey foot
```

6.8 Legacy Tables and Views

In releases of Spatial before 10.2, the coordinate systems functions and procedures used information provided in the following tables, some of which have new names or are now views instead of tables:

- MDSYS.CS_SRS (see [Section 6.8.1](#)) defined the valid coordinate systems. It associates each coordinate system with its well-known text description, which is in conformance with the standard published by the Open Geospatial Consortium (<http://www.opengeospatial.org>).
- MDSYS.SDO_ANGLE_UNITS (see [Section 6.8.2](#)) defines the valid angle units.
- MDSYS.SDO_AREA_UNITS (see [Section 6.8.3](#)) defines the valid area units.
- MDSYS.SDO_DIST_UNITS (see [Section 6.8.5](#)) defines the valid distance units.
- MDSYS.SDO_DATUMS_OLD_FORMAT and MDSYS.SDO_DATUMS_OLD_SNAPSHOT (see [Section 6.8.4](#)) are based on the MDSYS.SDO_DATUMS table before release 10.2, which defined valid datums.
- MDSYS.SDO_ELLIPSOIDS_OLD_FORMAT and MDSYS.SDO_ELLIPSOIDS_OLD_SNAPSHOT (see [Section 6.8.6](#)) are based on the MDSYS.SDO_ELLIPSOIDS table before release 10.2, which defined valid ellipsoids.
- MDSYS.SDO_PROJECTIONS_OLD_FORMAT and MDSYS.SDO_PROJECTIONS_OLD_SNAPSHOT (see [Section 6.8.7](#)) are based on the MDSYS.SDO_PROJECTIONS table before release 10.2, which defined the valid map projections.

Note: You should not modify or delete any Oracle-supplied information in these legacy tables.

If you refer to a legacy table in a SQL statement, you must include the *MDSYS.* before the table name.

6.8.1 MDSYS.CS_SRS Table

The MDSYS.CS_SRS reference table contains over 4000 rows, one for each valid coordinate system. This table contains the columns shown in [Table 6–28](#).

Table 6–28 MDSYS.CS_SRS Table

Column Name	Data Type	Description
CS_NAME	VARCHAR2(68)	A well-known name, often mnemonic, by which a user can refer to the coordinate system.
SRID	NUMBER(38)	The unique ID number (Spatial Reference ID) for a coordinate system. Currently, SRID values 1-999999 are reserved for use by Oracle Spatial, and values 1000000 (1 million) and higher are available for user-defined coordinate systems.
AUTH_SRID	NUMBER(38)	An optional ID number that can be used to indicate how the entry was derived; it might be a foreign key into another coordinate table, for example.
AUTH_NAME	VARCHAR2(256)	An authority name for the coordinate system. Contains <code>Oracle</code> in the supplied table. Users can specify any value in any rows that they add.
WKTEXT	VARCHAR2(2046)	The well-known text (WKT) description of the SRS, as defined by the Open Geospatial Consortium. For more information, see Section 6.8.1.1 .
CS_BOUNDS	SDO_GEOMETRY	An optional SDO_GEOMETRY object that is a polygon with WGS 84 longitude and latitude vertices, representing the spheroidal polygon description of the zone of validity for a projected coordinate system. Must be null for a geographic or non-Earth coordinate system. Is null in all supplied rows.

6.8.1.1 Well-Known Text (WKT)

The WKTEXT column of the MDSYS.CS_SRS table contains the well-known text (WKT) description of the SRS, as defined by the Open Geospatial Consortium. The following is the WKT EBNF syntax.

```

<coordinate system> ::=
    <horz cs> | <local cs>

<horz cs> ::=
    <geographic cs> | <projected cs>

<projected cs> ::=
    PROJCS [ "<name>", <geographic cs>, <projection>,
             {<parameter>,*} <linear unit> ]

<projection> ::=
    PROJECTION [ "<name>" ]

<parameter> ::=
    PARAMETER [ "<name>", <number> ]

<geographic cs> ::=
    GEOGCS [ "<name>", <datum>, <prime meridian>, <angular unit> ]

<datum> ::=
    DATUM [ "<name>", <spheroid>
            {, <shift-x>, <shift-y>, <shift-z>
              , <rot-x>, <rot-y>, <rot-z>, <scale_adjust>}
            ]

```

```

<spheroid> ::=
    SPHEROID [ "<name>", <semi major axis>, <inverse flattening> ]

<prime meridian> ::=
    PRIMEM [ "<name>", <longitude> ]

<longitude> ::=
    <number>

<semi-major axis> ::=
    <number>

<inverse flattening> ::=
    <number>

<angular unit> ::= <unit>

<linear unit> ::= <unit>

<unit> ::=
    UNIT [ "<name>", <conversion factor> ]

<local cs> ::=
    LOCAL_CS [ "<name>", <local datum>, <linear unit>,
              <axis> {, <axis>}* ]

<local datum> ::=
    LOCAL_DATUM [ "<name>", <datum type>
                 {, <shift-x>, <shift-y>, <shift-z>
                  , <rot-x>, <rot-y>, <rot-z>, <scale_adjust>}
                 ]

<datum type> ::=
    <number>

<axis> ::=
    AXIS [ "<name>", NORTH | SOUTH | EAST |
          WEST | UP | DOWN | OTHER ]

```

Each <parameter> specification is one of the following:

- Standard_Parallel_1 (in decimal degrees)
- Standard_Parallel_2 (in decimal degrees)
- Central_Meridian (in decimal degrees)
- Latitude_of_Origin (in decimal degrees)
- Azimuth (in decimal degrees)
- False_Easting (in the unit of the coordinate system; for example, meters)
- False_Northing (in the unit of the coordinate system; for example, meters)
- Perspective_Point_Height (in the unit of the coordinate system; for example, meters)
- Landsat_Number (must be 1, 2, 3, 4, or 5)
- Path_Number
- Scale_Factor

Note: If the WKT uses European rather than US-American notation for datum rotation parameters, or if the transformation results do not seem correct, see [Section 6.8.1.2](#).

The default value for each <parameter> specification is 0 (zero). That is, if a specification is needed for a projection but no value is specified in the WKT, Spatial uses a value of 0.

The prime meridian (PRIMEM) is specified in decimal degrees of longitude.

An example of the WKT for a geodetic (geographic) coordinate system is:

```
'GEOGCS [ "Longitude / Latitude (Old Hawaiian)", DATUM [ "Old Hawaiian", SPHEROID [ "Clarke 1866", 6378206.400000, 294.978698]], PRIMEM [ "Greenwich", 0.000000 ], UNIT [ "Decimal Degree", 0.01745329251994330]]'
```

The WKT definition of the coordinate system is hierarchically nested. The Old Hawaiian geographic coordinate system (GEOGCS) is composed of a named datum (DATUM), a prime meridian (PRIMEM), and a unit definition (UNIT). The datum is in turn composed of a named spheroid and its parameters of semi-major axis and inverse flattening.

An example of the WKT for a projected coordinate system (a Wyoming State Plane) is:

```
'PROJCS["Wyoming 4901, Eastern Zone (1983, meters)", GEOGCS [ "GRS 80", DATUM [ "GRS 80", SPHEROID [ "GRS 80", 6378137.000000, 298.257222]], PRIMEM [ "Greenwich", 0.000000 ], UNIT [ "Decimal Degree", 0.01745329251994330]], PROJECTION [ "Transverse Mercator", PARAMETER [ "Scale_Factor", 0.999938], PARAMETER [ "Central_Meridian", -105.166667], PARAMETER [ "Latitude_Of_Origin", 40.500000], PARAMETER [ "False_Easting", 200000.000000], UNIT [ "Meter", 1.000000000000]]'
```

The projected coordinate system contains a nested geographic coordinate system as its basis, as well as parameters that control the projection.

Oracle Spatial supports all common geodetic datums and map projections.

An example of the WKT for a local coordinate system is:

```
LOCAL_CS [ "Non-Earth (Meter)", LOCAL_DATUM [ "Local Datum", 0], UNIT [ "Meter", 1.0], AXIS [ "X", EAST], AXIS [ "Y", NORTH]]
```

For more information about local coordinate systems, see [Section 6.3](#).

You can use the [SDO_CS.VALIDATE_WKT](#) function, described in [Chapter 21](#), to validate the WKT of any coordinate system defined in the MDSYS.CS_SRS table.

6.8.1.2 US-American and European Notations for Datum Parameters

The datum-related WKT parameters are a list of up to seven Bursa Wolf transformation parameters. Rotation parameters specify arc seconds, and shift parameters specify meters.

Two different notations, US-American and European, are used for the three rotation parameters that are in general use, and these two notations use opposite signs. Spatial uses and expects the US-American notation. Therefore, if your WKT uses the European notation, you must convert it to the US-American notation by inverting the signs of the rotation parameters.

If you do not know if a parameter set uses the US-American or European notation, perform the following test:

1. Select a single point for which you know the correct result.
2. Perform the transformation using the current WKT.
3. If the computed result does not match the known correct result, invert signs of the rotation parameters, perform the transformation, and check if the computed result matches the known correct result.

6.8.1.3 Procedures for Updating the Well-Known Text

If you insert or delete a row in the SDO_COORD_REF_SYSTEM view (described in [Section 6.7.10](#)), Spatial automatically updates the WKTEXT column in the MDSYS.CS_SRS table. (The format of the WKTEXT column is described in [Section 6.8.1.1](#).) However, if you update an existing row in the SDO_COORD_REF_SYSTEM view, the well-known text (WKT) value is not automatically updated.

In addition, information relating to coordinate reference systems is also stored in several other system tables, including SDO_DATUMS (described in [Section 6.7.22](#)), SDO_ELLIPSOIDS (described in [Section 6.7.23](#)), and SDO_PRIME_MERIDIANS (described in [Section 6.7.26](#)). If you add, delete, or modify information in these tables, the WKTEXT values in the MDSYS.CS_SRS table are not automatically updated. For example, if you update an ellipsoid flattening value in the SDO_ELLIPSOIDS table, the well-known text string for the associated coordinate system is not updated.

However, you can manually update the WKTEXT values in the in the MDSYS.CS_SRS table by using any of several procedures whose names start with *UPDATE_WKTS_FOR* (for example, [SDO_CS.UPDATE_WKTS_FOR_ALL_EPSG_CRS](#) and [SDO_CS.UPDATE_WKTS_FOR_EPSG_DATUM](#)). If the display of SERVEROUTPUT information is enabled, these procedures display a message identifying the SRID value for each row in the MDSYS.CS_SRS table whose WKTEXT value is being updated. These procedures are described in [Chapter 21](#).

6.8.2 MDSYS.SDO_ANGLE_UNITS View

The MDSYS.SDO_ANGLE_UNITS reference view contains one row for each valid angle UNIT specification in the well-known text (WKT) description in the coordinate system definition. The WKT is described in [Section 6.8.1.1](#).

The MDSYS.SDO_ANGLE_UNITS view is based on the SDO_UNITS_OF MEASURE table (described in [Section 6.7.27](#)), and it contains the columns shown in [Table 6–29](#).

Table 6–29 MDSYS.SDO_ANGLE_UNITS View

Column Name	Data Type	Description
SDO_UNIT	VARCHAR2(32)	Name of the angle unit (often a shortened form of the UNIT_NAME value). Use the SDO_UNIT value with the <i>from_unit</i> and <i>to_unit</i> parameters of the SDO_UTIL.CONVERT_UNIT function.
UNIT_NAME	VARCHAR2(100)	Name of the angle unit. Specify a value from this column in the UNIT specification of the WKT for any user-defined coordinate system. Examples: Decimal Degree, Radian, Decimal Second, Decimal Minute, Gon, Grad.
CONVERSION_FACTOR	NUMBER	The ratio of the specified unit to one radian. For example, the ratio of Decimal Degree to Radian is 0.017453293.

6.8.3 MDSYS.SDO_AREA_UNITS View

The MDSYS.SDO_AREA_UNITS reference view contains one row for each valid area UNIT specification in the well-known text (WKT) description in the coordinate system definition. The WKT is described in [Section 6.8.1.1](#).

The MDSYS.SDO_AREA_UNITS view is based on the SDO_UNITS_OF MEASURE table (described in [Section 6.7.27](#)), and it contains the columns shown in [Table 6–30](#).

Table 6–30 SDO_AREA_UNITS View

Column Name	Data Type	Purpose
SDO_UNIT	VARCHAR2	Values are taken from the SHORT_NAME column of the SDO_UNITS_OF MEASURE table.
UNIT_NAME	VARCHAR2	Values are taken from the UNIT_OF_MEAS_NAME column of the SDO_UNITS_OF MEASURE table.
CONVERSION_FACTOR	NUMBER	Ratio of the unit to 1 square meter. For example, the conversion factor for a square meter is 1.0, and the conversion factor for a square mile is 2589988.

6.8.4 MDSYS.SDO_DATUMS_OLD_FORMAT and SDO_DATUMS_OLD_SNAPSHOT Tables

The MDSYS.SDO_DATUMS_OLD_FORMAT and MDSYS.SDO_DATUMS_OLD_SNAPSHOT reference tables contain one row for each valid DATUM specification in the well-known text (WKT) description in the coordinate system definition. (The WKT is described in [Section 6.8.1.1](#).)

- MDSYS.SDO_DATUMS_OLD_FORMAT contains the new data in the old format (that is, EPSG-based datum specifications in a table using the format from before release 10.2).
- MDSYS.SDO_DATUMS_OLD_SNAPSHOT contains the old data in the old format (that is, datum specifications and table format from before release 10.2).

These tables contain the columns shown in [Table 6–31](#).

Table 6–31 MDSYS.SDO_DATUMS_OLD_FORMAT and SDO_DATUMS_OLD_SNAPSHOT Tables

Column Name	Data Type	Description
NAME	VARCHAR2(80) for OLD_FORMAT VARCHAR2(64) for OLD_SNAPSHOT	Name of the datum. Specify a value (Oracle-supplied or user-defined) from this column in the DATUM specification of the WKT for any user-defined coordinate system. Examples: Adindan, Afgooye, Ain el Abd 1970, Anna 1 Astro 1965, Arc 1950, Arc 1960, Ascension Island 1958.
SHIFT_X	NUMBER	Number of meters to shift the ellipsoid center relative to the center of the WGS 84 ellipsoid on the x-axis.
SHIFT_Y	NUMBER	Number of meters to shift the ellipsoid center relative to the center of the WGS 84 ellipsoid on the y-axis.
SHIFT_Z	NUMBER	Number of meters to shift the ellipsoid center relative to the center of the WGS 84 ellipsoid on the z-axis.
ROTATE_X	NUMBER	Number of arc-seconds of rotation about the x-axis.

Table 6–31 (Cont.) MDSYS.SDO_DATUMS_OLD_FORMAT and SDO_DATUMS_OLD_SNAPSHOT Tables

Column Name	Data Type	Description
ROTATE_Y	NUMBER	Number of arc-seconds of rotation about the y-axis.
ROTATE_Z	NUMBER	Number of arc-seconds of rotation about the z-axis.
SCALE_ADJUST	NUMBER	A value to be used in adjusting the X, Y, and Z values after any shifting and rotation, according to the formula: $1.0 + (\text{SCALE_ADJUST} * 10^{-6})$

The following are the names (in tabular format) of the datums in these tables:

Adindan	Afgooye	Ain el Abd 1970
Anna 1 Astro 1965	Arc 1950	Arc 1960
Ascension Island 1958	Astro B4 Sorol Atoll	Astro Beacon E
Astro DOS 71/4	Astronomic Station 1952	Australian Geodetic 1966
Australian Geodetic 1984	Belgium Hayford	Bellevue (IGN)
Bermuda 1957	Bogota Observatory	CH 1903 (Switzerland)
Campo Inchauspe	Canton Astro 1966	Cape
Cape Canaveral	Carthage	Chatham 1971
Chua Astro	Corrego Alegre	DHDN (Potsdam/Rauenberg)
DOS 1968	Djakarta (Batavia)	Easter Island 1967
European 1950	European 1979	European 1987
GRS 67	GRS 80	GUX 1 Astro
Gandajika Base	Geodetic Datum 1949	Guam 1963
Hito XVIII 1963	Hjorsey 1955	Hong Kong 1963
Hu-Tzu-Shan	ISTS 073 Astro 1969	Indian (Bangladesh, etc.)
Indian (Thailand/Vietnam)	Ireland 1965	Johnston Island 1961
Kandawala	Kerguelen Island	Kertau 1948
L.C. 5 Astro	Liberia 1964	Lisboa (DLx)
Luzon (Mindanao Island)	Luzon (Philippines)	Mahe 1971
Marco Astro	Massawa	Melrica 1973 (D73)
Merchich	Midway Astro 1961	Minna
NAD 27 (Alaska)	NAD 27 (Bahamas)	NAD 27 (Canada)
NAD 27 (Canal Zone)	NAD 27 (Caribbean)	NAD 27 (Central America)
NAD 27 (Continental US)	NAD 27 (Cuba)	NAD 27 (Greenland)
NAD 27 (Mexico)	NAD 27 (Michigan)	NAD 27 (San Salvador)
NAD 83	NTF (Greenwich meridian)	NTF (Paris meridian)
NWGL 10	Nahrwan (Masirah Island)	Nahrwan (Saudi Arabia)

Nahrwan (Un. Arab Emirates)	Naparima, BWI	Netherlands Bessel
Observatorio 1966	Old Egyptian	Old Hawaiian
Oman	Ordinance Survey Great Brit	Pico de las Nieves
Pitcairn Astro 1967	Provisional South American	Puerto Rico
Pulkovo 1942	Qatar National	Qornoq
RT 90 (Sweden)	Reunion	Rome 1940
Santo (DOS)	Sao Braz	Sapper Hill 1943
Schwarzeck	South American 1969	South Asia
Southeast Base	Southwest Base	Timbalai 1948
Tokyo	Tristan Astro 1968	Viti Levu 1916
WGS 60	WGS 66	WGS 72
WGS 84	Wake-Eniwetok 1960	Yacare
Zanderij		

6.8.5 MDSYS.SDO_DIST_UNITS View

The MDSYS.SDO_DIST_UNITS reference view contains one row for each valid distance UNIT specification in the well-known text (WKT) description in the coordinate system definition. The WKT is described in [Section 6.8.1.1](#).

The MDSYS.SDO_DIST_UNITS view is based on the SDO_UNITS_OF MEASURE table (described in [Section 6.7.27](#)), and it contains the columns shown in [Table 6–32](#).

Table 6–32 MDSYS.SDO_DIST_UNITS View

Column Name	Data Type	Description
SDO_UNIT	VARCHAR2	Values are taken from the SHORT_NAME column of the SDO_UNITS_OF MEASURE table.
UNIT_NAME	VARCHAR2	Values are taken from the UNIT_OF_MEAS_NAME column of the SDO_UNITS_OF MEASURE table.
CONVERSION_FACTOR	NUMBER	Ratio of the unit to 1 meter. For example, the conversion factor for a meter is 1.0, and the conversion factor for a mile is 1609.344.

6.8.6 MDSYS.SDO_ELLIPSOIDS_OLD_FORMAT and SDO_ELLIPSOIDS_OLD_SNAPSHOT Tables

The MDSYS.SDO_ELLIPSOIDS_OLD_FORMAT and MDSYS.SDO_ELLIPSOIDS_OLD_SNAPSHOT reference tables contain one row for each valid SPHEROID specification in the well-known text (WKT) description in the coordinate system definition. (The WKT is described in [Section 6.8.1.1](#).)

- MDSYS.SDO_ELLIPSOIDS_OLD_FORMAT contains the new data in the old format (that is, EPSG-based ellipsoid specifications in a table using the format from before release 10.2).
- MDSYS.SDO_ELLIPSOIDS_OLD_SNAPSHOT contains the old data in the old format (that is, ellipsoid specifications and table format from before release 10.2).

These tables contain the columns shown in [Table 6–33](#).

Table 6–33 MDSYS.SDO_ELLIPSOIDS_OLD_FORMAT and SDO_ELLIPSOIDS_OLD_SNAPSHOT Tables

Column Name	Data Type	Description
NAME	VARCHAR2(80) for OLD_FORMAT VARCHAR2(64) for OLD_SNAPSHOT	Name of the ellipsoid (spheroid). Specify a value from this column in the SPHEROID specification of the WKT for any user-defined coordinate system. Examples: Clarke 1866, WGS 72, Australian, Krassovsky, International 1924.
SEMI_MAJOR_AXIS	NUMBER	Radius in meters along the semi-major axis (one-half of the long axis of the ellipsoid).
INVERSE_FLATTENING	NUMBER	Inverse flattening of the ellipsoid. That is, $1/f$, where $f = (a-b)/a$, and a is the semi-major axis and b is the semi-minor axis.

The following are the names (in tabular format) of the ellipsoids in these tables:

Airy 1830	Airy 1830 (Ireland 1965)	Australian
Bessel 1841	Bessel 1841 (NGO 1948)	Bessel 1841 (Schwarzeck)
Clarke 1858	Clarke 1866	Clarke 1866 (Michigan)
Clarke 1880	Clarke 1880 (Arc 1950)	Clarke 1880 (IGN)
Clarke 1880 (Jamaica)	Clarke 1880 (Merchich)	Clarke 1880 (Palestine)
Everest	Everest (Kalianpur)	Everest (Kertau)
Everest (Timbalai)	Fischer 1960 (Mercury)	Fischer 1960 (South Asia)
Fischer 1968	GRS 67	GRS 80
Hayford	Helmert 1906	Hough
IAG 75	Indonesian	International 1924
Krassovsky	MERIT 83	NWL 10D
NWL 9D	New International 1967	OSU86F
OSU91A	Plessis 1817	South American 1969
Sphere (6370997m)	Struve 1860	WGS 60
WGS 66	WGS 72	WGS 84
Walbeck	War Office	

6.8.7 MDSYS.SDO_PROJECTIONS_OLD_FORMAT and SDO_PROJECTIONS_OLD_SNAPSHOT Tables

The MDSYS.SDO_PROJECTIONS_OLD_FORMAT and MDSYS.SDO_PROJECTIONS_OLD_SNAPSHOT reference tables contain one row for each valid PROJECTION specification in the well-known text (WKT) description in the coordinate system definition. (The WKT is described in [Section 6.8.1.1](#).)

- MDSYS.SDO_PROJECTIONS_OLD_FORMAT contains the new data in the old format (that is, EPSG-based projection specifications in a table using the format from before release 10.2).

- MDSYS.SDO_PROJECTIONS_OLD_SNAPSHOT contains the old data in the old format (that is, projection specifications and table format from before release 10.2).

These tables contains the column shown in [Table 6–34](#).

Table 6–34 MDSYS.SDO_PROJECTIONS_OLD_FORMAT and SDO_PROJECTIONS_OLD_SNAPSHOT Tables

Column Name	Data Type	Description
NAME	VARCHAR2(80) for OLD_FORMAT VARCHAR2(64) for OLD_ SNAPSHOT	Name of the map projection. Specify a value from this column in the PROJECTION specification of the WKT for any user-defined coordinate system. Examples: Geographic (Lat/Long), Universal Transverse Mercator, State Plane Coordinates, Albers Conical Equal Area.

The following are the names (in tabular format) of the projections in these tables:

Alaska Conformal	Albers Conical Equal Area
Azimuthal Equidistant	Bonne
Cassini	Cylindrical Equal Area
Eckert IV	Eckert VI
Equidistant Conic	Equirectangular
Gall	General Vertical Near-Side Perspective
Geographic (Lat/Long)	Gnomonic
Hammer	Hotine Oblique Mercator
Interrupted Goode Homolosine	Interrupted Mollweide
Lambert Azimuthal Equal Area	Lambert Conformal Conic
Lambert Conformal Conic (Belgium 1972)	Mercator
Miller Cylindrical	Mollweide
New Zealand Map Grid	Oblated Equal Area
Orthographic	Polar Stereographic
Polyconic	Robinson
Sinusoidal	Space Oblique Mercator
State Plane Coordinates	Stereographic
Swiss Oblique Mercator	Transverse Mercator
Transverse Mercator Danish System 34 Jylland-Fyn	Transverse Mercator Danish System 45 Bornholm
Transverse Mercator Finnish KKJ	Transverse Mercator Sjaelland
Universal Transverse Mercator	Van der Grinten
Wagner IV	Wagner VII

6.9 Creating a User-Defined Coordinate Reference System

If the coordinate systems supplied by Oracle are not sufficient for your needs, you can create user-defined coordinate reference systems.

Note: As mentioned in [Section 6.1.1](#), the terms *coordinate system* and *coordinate reference system* (CRS) are often used interchangeably, although coordinate reference systems must be Earth-based.

The exact steps for creating a user-defined CRS depend on whether it is geodetic or projected. In both cases, supply information about the coordinate system (coordinate axes, axis names, unit of measurement, and so on). For a geodetic CRS, supply information about the datum (ellipsoid, prime meridian, and so on), as explained in [Section 6.9.1](#). For a projected CRS, supply information about the source (geodetic) CRS and the projection (operation and parameters), as explained in [Section 6.9.2](#).

For any user-defined coordinate system, the SRID value should be 1000000 (1 million) or higher.

6.9.1 Creating a Geodetic CRS

If the necessary unit of measurement, coordinate axes, SDO_COORD_SYS table row, ellipsoid, prime meridian, and datum are already defined, insert a row into the SDO_COORD_REF_SYSTEM view (described in [Section 6.7.10](#)) to define the new geodetic CRS.

[Example 6–5](#) inserts the definition for a hypothetical geodetic CRS named `My Own NAD27` (which, except for its SRID and name, is the same as the NAD27 CRS supplied by Oracle).

Example 6–5 Creating a User-Defined Geodetic Coordinate Reference System

```
INSERT INTO SDO_COORD_REF_SYSTEM (
    SRID,
    COORD_REF_SYS_NAME,
    COORD_REF_SYS_KIND,
    COORD_SYS_ID,
    DATUM_ID,
    GEOG_CRD_DATUM_ID,
    SOURCE_GEOG_SRID,
    PROJECTION_CONV_ID,
    CMPD_HORIZ_SRID,
    CMPD_VERT_SRID,
    INFORMATION_SOURCE,
    DATA_SOURCE,
    IS_LEGACY,
    LEGACY_CODE,
    LEGACY_WKTEXT,
    LEGACY_CS_BOUNDS,
    IS_VALID,
    SUPPORTS_SDO_GEOMETRY)
VALUES (
    9994267,
    'My Own NAD27',
    'GEOGRAPHIC2D',
    6422,
    6267,
    6267,
```

```

NULL,
NULL,
NULL,
NULL,
NULL,
'EPSG',
'FALSE',
NULL,
NULL,
NULL,
'TRUE',
'TRUE');

```

If the necessary information for the definition does not already exist, follow these steps, as needed, to define the information before you insert the row into the SDO_COORD_REF_SYSTEM view:

1. If the unit of measurement is not already defined in the SDO_UNITS_OF_MEASURE table (described in [Section 6.7.27](#)), insert a row into that table to define the new unit of measurement.
2. If the coordinate axes are not already defined in the SDO_COORD_AXES table (described in [Section 6.7.1](#)), insert one row into that table for each new coordinate axis.
3. If an appropriate entry for the coordinate system does not already exist in the SDO_COORD_SYS table (described in [Section 6.7.11](#)), insert a row into that table. [Example 6–6](#) inserts the definition for a fictitious coordinate system.

Example 6–6 Inserting a Row into the SDO_COORD_SYS Table

```

INSERT INTO SDO_COORD_SYS (
    COORD_SYS_ID,
    COORD_SYS_NAME,
    COORD_SYS_TYPE,
    DIMENSION,
    INFORMATION_SOURCE,
    DATA_SOURCE)
VALUES (
    9876543,
    'My custom CS. Axes: lat, long. Orientations: north, east. UoM: deg',
    'ellipsoidal',
    2,
    'Myself',
    'Myself');

```

4. If the ellipsoid is not already defined in the SDO_ELLIPSOIDS table (described in [Section 6.7.23](#)), insert a row into that table to define the new ellipsoid.
5. If the prime meridian is not already defined in the SDO_PRIME_MERIDIANS table (described in [Section 6.7.26](#)), insert a row into that table to define the new prime meridian.
6. If the datum is not already defined in the SDO_DATUMS table (described in [Section 6.7.22](#)), insert a row into that table to define the new datum.

6.9.2 Creating a Projected CRS

If the necessary unit of measurement, coordinate axes, SDO_COORD_SYS table row, source coordinate system, projection operation, and projection parameters are already

defined, insert a row into the SDO_COORD_REF_SYSTEM view (described in [Section 6.7.10](#)) to define the new projected CRS.

Example 6–7 inserts the definition for a hypothetical projected CRS named `My Own NAD27 / Cuba Norte` (which, except for its SRID and name, is the same as the `NAD27 / Cuba Norte` CRS supplied by Oracle).

Example 6–7 Creating a User-Defined Projected Coordinate Reference System

```
INSERT INTO SDO_COORD_REF_SYSTEM (
    SRID,
    COORD_REF_SYS_NAME,
    COORD_REF_SYS_KIND,
    COORD_SYS_ID,
    DATUM_ID,
    GEOG_CRS_DATUM_ID,
    SOURCE_GEOG_SRID,
    PROJECTION_CONV_ID,
    CMPD_HORIZ_SRID,
    CMPD_VERT_SRID,
    INFORMATION_SOURCE,
    DATA_SOURCE,
    IS_LEGACY,
    LEGACY_CODE,
    LEGACY_WKTEXT,
    LEGACY_CS_BOUNDS,
    IS_VALID,
    SUPPORTS_SDO_GEOMETRY)
VALUES (
    9992085,
    'My Own NAD27 / Cuba Norte',
    'PROJECTED',
    4532,
    NULL,
    6267,
    4267,
    18061,
    NULL,
    NULL,
    'Institut Cubano di Hidrografia (ICH)',
    'EPSG',
    'FALSE',
    NULL,
    NULL,
    NULL,
    'TRUE',
    'TRUE');
```

If the necessary information for the definition does not already exist, follow these steps, as needed, to define the information before you insert the row into the SDO_COORD_REF_SYSTEM view:

1. If the unit of measurement is not already defined in the SDO_UNITS_OF_MEASURE table (described in [Section 6.7.27](#)), insert a row into that table to define the new unit of measurement.
2. If the coordinate axes are not already defined in the SDO_COORD_AXES table (described in [Section 6.7.1](#)), insert one row into that table for each new coordinate axis.

3. If an appropriate entry for the coordinate system does not already exist in SDO_COORD_SYS table (described in [Section 6.7.11](#)), insert a row into that table. (See [Example 6–6](#) in [Section 6.9.1](#)).
4. If the projection operation is not already defined in the SDO_COORD_OPS table (described in [Section 6.7.8](#)), insert a row into that table to define the new projection operation. [Example 6–8](#) shows the statement used to insert information about coordinate operation ID 18061, which is supplied by Oracle.

Example 6–8 Inserting a Row into the SDO_COORD_OPS Table

```

INSERT INTO SDO_COORD_OPS (
    COORD_OP_ID,
    COORD_OP_NAME,
    COORD_OP_TYPE,
    SOURCE_SRID,
    TARGET_SRID,
    COORD_TFM_VERSION,
    COORD_OP_VARIANT,
    COORD_OP_METHOD_ID,
    UOM_ID_SOURCE_OFFSETS,
    UOM_ID_TARGET_OFFSETS,
    INFORMATION_SOURCE,
    DATA_SOURCE,
    SHOW_OPERATION,
    IS_LEGACY,
    LEGACY_CODE,
    REVERSE_OP,
    IS_IMPLEMENTED_FORWARD,
    IS_IMPLEMENTED_REVERSE)
VALUES (
    18061,
    'Cuba Norte',
    'CONVERSION',
    NULL,
    NULL,
    NULL,
    NULL,
    9801,
    NULL,
    NULL,
    NULL,
    'EPSG',
    1,
    'FALSE',
    NULL,
    1,
    1,
    1);

```

5. If the parameters for the projection operation are not already defined in the SDO_COORD_OP_PARAM_VALS table (described in [Section 6.7.5](#)), insert one row into that table for each new parameter. [Example 6–9](#) shows the statement used to insert information about parameters with ID values 8801, 8802, 8805, 8806, and 8807, which are supplied by Oracle.

Example 6–9 Inserting a Row into the SDO_COORD_OP_PARAM_VALS Table

```

INSERT INTO SDO_COORD_OP_PARAM_VALS (
    COORD_OP_ID,

```

```

        COORD_OP_METHOD_ID,
        PARAMETER_ID,
        PARAMETER_VALUE,
        PARAM_VALUE_FILE_REF,
        UOM_ID)
VALUES (
    18061,
    9801,
    8801,
    22.21,
    NULL,
    9110);

INSERT INTO SDO_COORD_OP_PARAM_VALS (
    COORD_OP_ID,
    COORD_OP_METHOD_ID,
    PARAMETER_ID,
    PARAMETER_VALUE,
    PARAM_VALUE_FILE_REF,
    UOM_ID)
VALUES (
    18061,
    9801,
    8802,
    -81,
    NULL,
    9110);

INSERT INTO SDO_COORD_OP_PARAM_VALS (
    COORD_OP_ID,
    COORD_OP_METHOD_ID,
    PARAMETER_ID,
    PARAMETER_VALUE,
    PARAM_VALUE_FILE_REF,
    UOM_ID)
VALUES (
    18061,
    9801,
    8805,
    .99993602,
    NULL,
    9201);

INSERT INTO SDO_COORD_OP_PARAM_VALS (
    COORD_OP_ID,
    COORD_OP_METHOD_ID,
    PARAMETER_ID,
    PARAMETER_VALUE,
    PARAM_VALUE_FILE_REF,
    UOM_ID)
VALUES (
    18061,
    9801,
    8806,
    500000,
    NULL,
    9001);

INSERT INTO SDO_COORD_OP_PARAM_VALS (
    COORD_OP_ID,

```



```

        COORD_OP_METHOD_ID,
        PARAMETER_ID,
        PARAMETER_VALUE,
        PARAM_VALUE_FILE_REF,
        UOM_ID)
VALUES (
    18061,
    9801,
    8807,
    280296.016,
    NULL,
    9001);

```

Example 6–10 provides an extended, annotated example of creating a user-defined projected coordinate system

Example 6–10 Creating a User-Defined Projected CRS: Extended Example

```

-- Create an EPSG equivalent for the following CRS:
--
-- CS_NAME:      VDOT_LAMBERT
-- SRID:         51000000
-- AUTH_SRID:    51000000
-- AUTH_NAME:    VDOT Custom Lambert Conformal Conic
-- WKTEXT:
--
-- PROJCS[
--   "VDOT_Lambert",
--   GEOGCS[
--     "GCS_North_American_1983",
--     DATUM[
--       "D_North_American_1983",
--       SPHEROID["GRS_1980", 6378137.0, 298.257222101]],
--       PRIMEM["Greenwich", 0.0],
--       UNIT["Decimal Degree",0.0174532925199433]],
--     PROJECTION["Lambert_Conformal_Conic"],
--     PARAMETER["False_Easting", 0.0],
--     PARAMETER["False_Northing", 0.0],
--     PARAMETER["Central_Meridian", -79.5],
--     PARAMETER["Standard_Parallel_1", 37.0],
--     PARAMETER["Standard_Parallel_2", 39.5],
--     PARAMETER["Scale_Factor", 1.0],
--     PARAMETER["Latitude_Of_Origin", 36.0],
--     UNIT["Meter", 1.0]]
--
-- First, the base geographic CRS (GCS_North_American_1983) already exists in
EPG.
-- It is 4269:
-- Next, find the EPSG equivalent for PROJECTION["Lambert_Conformal_Conic"]:
select
    coord_op_method_id,
    legacy_name
from
    sdo_coord_op_methods
where
    not legacy_name is null
order by
    coord_op_method_id;

-- Result:

```

```

-- COORD_OP_METHOD_ID LEGACY_NAME
-- -----
--          9802 Lambert Conformal Conic
--          9803 Lambert Conformal Conic (Belgium 1972)
--          9805 Mercator
--          9806 Cassini
--          9807 Transverse Mercator
--          9829 Polar Stereographic
--
-- 6 rows selected.
--
-- It is EPSG method 9802. Create a projection operation 510000001, based on it:

insert into MDSYS.SDO_COORD_OPS (
    COORD_OP_ID,
    COORD_OP_NAME,
    COORD_OP_TYPE,
    SOURCE_SRID,
    TARGET_SRID,
    COORD_TFM_VERSION,
    COORD_OP_VARIANT,
    COORD_OP_METHOD_ID,
    UOM_ID_SOURCE_OFFSETS,
    UOM_ID_TARGET_OFFSETS,
    INFORMATION_SOURCE,
    DATA_SOURCE,
    SHOW_OPERATION,
    IS_LEGACY,
    LEGACY_CODE,
    REVERSE_OP,
    IS_IMPLEMENTED_FORWARD,
    IS_IMPLEMENTED_REVERSE)
VALUES (
    510000001,
    'VDOT_Lambert',
    'CONVERSION',
    NULL,
    NULL,
    NULL,
    NULL,
    9802,
    NULL,
    NULL,
    NULL,
    NULL,
    NULL,
    1,
    'FALSE',
    NULL,
    1,
    1,
    1);

-- Now, set the parameters. See which are required:

select
    use.parameter_id || ': ' ||
    use.legacy_param_name
from
    sdo_coord_op_param_use use
where

```

```
use.coord_op_method_id = 9802;

-- result:
-- 8821: Latitude_Of_Origin
-- 8822: Central_Meridian
-- 8823: Standard_Parallel_1
-- 8824: Standard_Parallel_2
-- 8826: False_Easting
-- 8827: False_Northing
--
-- 6 rows selected.

-- Also check the most common units we will need:

select
  UOM_ID || ': ' ||
  UNIT_OF_MEAS_NAME
from
  sdo_units_of_measure
where
  uom_id in (9001, 9101, 9102, 9201)
order by
  uom_id;

-- result:
-- 9001: metre
-- 9101: radian
-- 9102: degree
-- 9201: unity

-- Now, configure the projection parameters:

-- 8821: Latitude_Of_Origin

insert into MDSYS.SDO_COORD_OP_PARAM_VALS (
  COORD_OP_ID,
  COORD_OP_METHOD_ID,
  PARAMETER_ID,
  PARAMETER_VALUE,
  PARAM_VALUE_FILE_REF,
  UOM_ID)
VALUES (
  510000001,
  9802,
  8821,
  36.0,
  NULL,
  9102);

-- 8822: Central_Meridian

insert into MDSYS.SDO_COORD_OP_PARAM_VALS (
  COORD_OP_ID,
  COORD_OP_METHOD_ID,
  PARAMETER_ID,
  PARAMETER_VALUE,
  PARAM_VALUE_FILE_REF,
  UOM_ID)
VALUES (
  510000001,
```

```

        9802,
        8822,
        -79.5,
        NULL,
        9102);

-- 8823: Standard_Parallel_1

insert into MDSYS.SDO_COORD_OP_PARAM_VALS (
    COORD_OP_ID,
    COORD_OP_METHOD_ID,
    PARAMETER_ID,
    PARAMETER_VALUE,
    PARAM_VALUE_FILE_REF,
    UOM_ID)
VALUES (
    510000001,
    9802,
    8823,
    37.0,
    NULL,
    9102);

-- 8824: Standard_Parallel_2

insert into MDSYS.SDO_COORD_OP_PARAM_VALS (
    COORD_OP_ID,
    COORD_OP_METHOD_ID,
    PARAMETER_ID,
    PARAMETER_VALUE,
    PARAM_VALUE_FILE_REF,
    UOM_ID)
VALUES (
    510000001,
    9802,
    8824,
    39.5,
    NULL,
    9102);

-- 8826: False_Easting

insert into MDSYS.SDO_COORD_OP_PARAM_VALS (
    COORD_OP_ID,
    COORD_OP_METHOD_ID,
    PARAMETER_ID,
    PARAMETER_VALUE,
    PARAM_VALUE_FILE_REF,
    UOM_ID)
VALUES (
    510000001,
    9802,
    8826,
    0.0,
    NULL,
    9001);

-- 8827: False_Northing

insert into MDSYS.SDO_COORD_OP_PARAM_VALS (

```

```

        COORD_OP_ID,
        COORD_OP_METHOD_ID,
        PARAMETER_ID,
        PARAMETER_VALUE,
        PARAM_VALUE_FILE_REF,
        UOM_ID)
VALUES (
    510000001,
    9802,
    8827,
    0.0,
    NULL,
    9001);

-- Now, create the actual projected CRS. Look at the GEOG_CRS_DATUM_ID
-- and COORD_SYS_ID first. The GEOG_CRS_DATUM_ID is the datum of
-- the base geog_crs (4269):

select datum_id from sdo_coord_ref_sys where srid = 4269;

--   DATUM_ID
--   -----
--       6269

-- And the COORD_SYS_ID is the Cartesian CS used for the projected CRS.
-- We can use 4400, if meters will be the unit:

select COORD_SYS_NAME from sdo_coord_sys where COORD_SYS_ID = 4400;

-- Cartesian 2D CS. Axes: easting, northing (E,N). Orientations: east, north.
-- UoM: m.

-- Now create the projected CRS:

insert into MDSYS.SDO_COORD_REF_SYSTEM (
    SRID,
    COORD_REF_SYS_NAME,
    COORD_REF_SYS_KIND,
    COORD_SYS_ID,
    DATUM_ID,
    SOURCE_GEOG_SRID,
    PROJECTION_CONV_ID,
    CMPD_HORIZ_SRID,
    CMPD_VERT_SRID,
    INFORMATION_SOURCE,
    DATA_SOURCE,
    IS_LEGACY,
    LEGACY_CODE,
    LEGACY_WKTEXT,
    LEGACY_CS_BOUNDS,
    GEOG_CRS_DATUM_ID)
VALUES (
    51000000,
    'VDOT_LAMBERT',
    'PROJECTED',
    4400,
    NULL,
    4269,
    510000001,
    NULL,

```

```

        NULL,
        NULL,
        NULL,
        'FALSE',
        NULL,
        NULL,
        NULL,
        6269);

-- To see the result:

select srid, wktext from cs_srs where srid = 51000000;

-- 51000000
-- PROJCS[
--   "VDOT_LAMBERT",
--   GEOGCS [
--     "NAD83",
--     DATUM [
--       "North American Datum 1983 (EPSG ID 6269)",
--       SPHEROID [
--         "GRS 1980 (EPSG ID 7019)",
--         6378137,
--         298.257222101]],
--     PRIMEM [ "Greenwich", 0.000000 ],
--     UNIT ["Decimal Degree", 0.01745329251994328]],
--   PROJECTION ["VDOT_Lambert"],
--   PARAMETER ["Latitude_Of_Origin", 36],
--   PARAMETER ["Central_Meridian", -79.5000000000000000000000000000000000000000000000028],
--   PARAMETER ["Standard_Parallel_1", 37],
--   PARAMETER ["Standard_Parallel_2", 39.5],
--   PARAMETER ["False_Easting", 0],
--   PARAMETER ["False_Northing", 0],
--   UNIT ["Meter", 1]]
```

6.9.3 Creating a Vertical CRS

A vertical CRS has only one dimension, usually height. On its own, a vertical CRS is of little use, but it can be combined with a two-dimensional CRS (geodetic or projected), to result in a compound CRS. [Example 6–11](#) shows the statement that created the vertical CRS with SRID 5701, which is included with Spatial. This definition refers to an existing (one-dimensional) coordinate system (ID 6499; see [Section 6.7.11](#), "SDO_COORD_SYS Table") and vertical datum (ID 5101; see [Section 6.7.22](#), "SDO_DATUMS Table").

Example 6–11 Creating a Vertical Coordinate Reference System

```

INSERT INTO MDSYS.SDO_COORD_REF_SYSTEM (
    SRID,
    COORD_REF_SYS_NAME,
    COORD_REF_SYS_KIND,
    COORD_SYS_ID,
    DATUM_ID,
    SOURCE_GEOG_SRID,
    PROJECTION_CONV_ID,
    CMPD_HORIZ_SRID,
    CMPD_VERT_SRID,
    INFORMATION_SOURCE,
    DATA_SOURCE,
    IS_LEGACY,
```

```

LEGACY_CODE,
LEGACY_WKTEXT,
LEGACY_CS_BOUNDS)
VALUES (
5701,
'Newlyn',
'VERTICAL',
6499,
5101,
NULL,
NULL,
NULL,
NULL,
NULL,
'EPSG',
'FALSE',
NULL,
NULL,
NULL);

```

A vertical CRS might define some undulating equipotential surface. The shape of that surface, and its offset from some ellipsoid, is not actually defined in the vertical CRS record itself (other than textually). Instead, that definition is included in an operation between the vertical CRS and another CRS. Consequently, you can define several alternative operations between the same pair of geoidal and WGS84-ellipsoidal heights. For example, there are geoid offset matrixes GEOID90, GEOID93, GEOID96, GEOID99, GEOID03, GEOID06, and others, and for each of these variants there can be a separate operation. [Section 6.9.6](#) describes such an operation.

6.9.4 Creating a Compound CRS

A compound CRS combines an existing horizontal (two-dimensional) CRS and a vertical (one-dimensional) CRS. The horizontal CRS can be geodetic or projected. [Example 6–12](#) shows the statement that created the compound CRS with SRID 7405, which is included with Spatial. This definition refers to an existing projected CRS and vertical CRS (IDs 27700 and 5701, respectively; see [Section 6.7.9](#), "SDO_COORD_REF_SYS Table").

Example 6–12 *Creating a Compound Coordinate Reference System*

```

INSERT INTO MDSYS.SDO_COORD_REF_SYSTEM (
SRID,
COORD_REF_SYS_NAME,
COORD_REF_SYS_KIND,
COORD_SYS_ID,
DATUM_ID,
SOURCE_GEOG_SRID,
PROJECTION_CONV_ID,
CMPD_HORIZ_SRID,
CMPD_VERT_SRID,
INFORMATION_SOURCE,
DATA_SOURCE,
IS_LEGACY,
LEGACY_CODE,
LEGACY_WKTEXT,
LEGACY_CS_BOUNDS)
VALUES (
7405,
'OSGB36 / British National Grid + ODN',

```

```
'COMPOUND',
NULL,
NULL,
NULL,
NULL,
27700,
5701,
NULL,
'EPSG',
'FALSE',
NULL,
NULL,
NULL);
```

6.9.5 Creating a Geographic 3D CRS

A geographic 3D CRS is the combination of a geographic 2D CRS with ellipsoidal height. [Example 6–13](#) shows the statement that created the geographic 3D CRS with SRID 4327, which is included with Spatial. This definition refers to an existing projected coordinate system (ID 6401; see [Section 6.7.11, "SDO_COORD_SYS Table"](#)) and datum (ID 6326; see [Section 6.7.22, "SDO_DATUMS Table"](#)).

Example 6–13 *Creating a Geographic 3D Coordinate Reference System*

```
INSERT INTO MDSYS.SDO_COORD_REF_SYSTEM (
  SRID,
  COORD_REF_SYS_NAME,
  COORD_REF_SYS_KIND,
  COORD_SYS_ID,
  DATUM_ID,
  GEOG_CRD_DATUM_ID,
  SOURCE_GEOG_SRID,
  PROJECTION_CONV_ID,
  CMPD_HORIZ_SRID,
  CMPD_VERT_SRID,
  INFORMATION_SOURCE,
  DATA_SOURCE,
  IS_LEGACY,
  LEGACY_CODE,
  LEGACY_WKTEXT,
  LEGACY_CS_BOUNDS,
  IS_VALID,
  SUPPORTS_SDO_GEOMETRY)
VALUES (
  4327,
  'WGS 84 (geographic 3D)',
  'GEOGRAPHIC3D',
  6401,
  6326,
  6326,
  NULL,
  NULL,
  NULL,
  NULL,
  'NIMA TR8350.2 January 2000 revision. http://164.214.2.59/GandG/tr8350_2.html',
  'EPSG',
  'FALSE',
  NULL,
  NULL,
  NULL,
```



```
'TRUE',
'TRUE');
```

6.9.6 Creating a Transformation Operation

Section 6.9.2 described the creation of a projection operation, for the purpose of then creating a projected CRS. A similar requirement can arise when using a compound CRS based on orthometric height: you may want to transform from and to ellipsoidal height. The offset between the two heights is undulating and irregular.

By default, Spatial transforms between ellipsoidal and orthometric height using an identity transformation. (Between different ellipsoids, the default would instead be a datum transformation.) The identity transformation is a reasonable approximation; however, a more accurate approach involves an EPSG type 9635 operation, involving an offset matrix. Example 6–14 is a declaration of such an operation:

Example 6–14 Creating a Transformation Operation

```
INSERT INTO MDSYS.SDO_COORD_OPS (
  COORD_OP_ID,
  COORD_OP_NAME,
  COORD_OP_TYPE,
  SOURCE_SRID,
  TARGET_SRID,
  COORD_TFM_VERSION,
  COORD_OP_VARIANT,
  COORD_OP_METHOD_ID,
  UOM_ID_SOURCE_OFFSETS,
  UOM_ID_TARGET_OFFSETS,
  INFORMATION_SOURCE,
  DATA_SOURCE,
  SHOW_OPERATION,
  IS_LEGACY,
  LEGACY_CODE,
  REVERSE_OP,
  IS_IMPLEMENTED_FORWARD,
  IS_IMPLEMENTED_REVERSE)
VALUES (
  999998,
  'Test operation, based on GEOID03 model, using Hawaii grid',
  'TRANSFORMATION',
  NULL,
  NULL,
  NULL,
  NULL,
  9635,
  NULL,
  NULL,
  'NGS',
  'NGS',
  1,
  'FALSE',
  NULL,
  1,
  1,
  1);

INSERT INTO MDSYS.SDO_COORD_OP_PARAM_VALS (
  COORD_OP_ID,
  COORD_OP_METHOD_ID,
```

```

PARAMETER_ID,
PARAMETER_VALUE,
PARAM_VALUE_FILE_REF,
UOM_ID)
VALUES (
  999998,
  9635,
  8666,
  NULL,
  'g2003h01.asc',
  NULL);

```

The second INSERT statement in [Example 6–14](#) specifies the file name `g2003h01.asc`, but not yet its actual CLOB content with the offset matrix. As with NADCON and NTV2 matrixes, geoid matrixes have to be loaded into the `PARAM_VALUE_FILE` column. Due to space and copyright considerations, Oracle does not supply most of these matrixes; however, they are usually available for download on the Web. Good sources are the relevant government websites, and you can search by file name (such as `g2003h01` in this example). Although some of these files are available in both binary format (such as `.gsb`) and ASCII format (such as `.gsa` or `.asc`), only the ASCII variant can be used with Spatial. The existing EPSG operations include file names in standard use.

[Example 6–15](#) is a script for loading a set of such matrixes. It loads specified physical files (such as `ntv20.gsa`) into database CLOBs, based on the official file name reference (such as `NTV2_0.GSB`).

Example 6–15 Loading Offset Matrixes

```

DECLARE
  ORCL_HOME_DIR VARCHAR2(128);
  ORCL_WORK_DIR VARCHAR2(128);
  Src_loc        BFILE;
  Dest_loc       CLOB;
  CURSOR PARAM_FILES IS
    SELECT
      COORD_OP_ID,
      PARAMETER_ID,
      PARAM_VALUE_FILE_REF
    FROM
      MDSYS.SDO_COORD_OP_PARAM_VALS
    WHERE
      PARAMETER_ID IN (8656, 8657, 8658, 8666);
  PARAM_FILE PARAM_FILES%ROWTYPE;
  ACTUAL_FILE_NAME VARCHAR2(128);
  platform NUMBER;
BEGIN
  EXECUTE IMMEDIATE 'CREATE OR REPLACE DIRECTORY work_dir AS ''define_your_source_directory_here''';

  FOR PARAM_FILE IN PARAM_FILES LOOP
    CASE UPPER(PARAM_FILE.PARAM_VALUE_FILE_REF)
      /* NTV2, fill in your files here */
      WHEN 'NTV2_0.GSB' THEN ACTUAL_FILE_NAME := 'ntv20.gsa';
      /* GEOID03, fill in your files here */
      WHEN 'G2003H01.ASC' THEN ACTUAL_FILE_NAME := 'g2003h01.asc';
      ELSE
        ACTUAL_FILE_NAME := NULL;
    END CASE;

    IF (NOT (ACTUAL_FILE_NAME IS NULL)) THEN

```

```

BEGIN
    dbms_output.put_line('Loading file ' || actual_file_name || '...');
    Src_loc := BFILENAME('WORK_DIR', ACTUAL_FILE_NAME);
    DBMS_LOB.OPEN(Src_loc, DBMS_LOB.LOB_READONLY);
END;

UPDATE
    MDSYS.SDO_COORD_OP_PARAM_VALS
SET
    PARAM_VALUE_FILE = EMPTY_CLOB()
WHERE
    COORD_OP_ID = PARAM_FILE.COORD_OP_ID AND
    PARAMETER_ID = PARAM_FILE.PARAMETER_ID
RETURNING
    PARAM_VALUE_FILE INTO Dest_loc;

DBMS_LOB.OPEN(Dest_loc, DBMS_LOB.LOB_READWRITE);
DBMS_LOB.LOADFROMFILE(Dest_loc, Src_loc, DBMS_LOB.LOBMAXSIZE);
DBMS_LOB.CLOSE(Dest_loc);
DBMS_LOB.CLOSE(Src_loc);
DBMS_LOB.FILECLOSE(Src_loc);
END IF;
END LOOP;
END;
/

```

6.9.7 Using British Grid Transformation OSTN02/OSGM02 (EPSG Method 9633)

To use British Grid Transformation OSTN02/OSGM02 (EPSG method 9633) in a projected coordinate reference system, you must first insert a modified version of the OSTN02_OSGM02_GB.txt grid file into the PARAM_VALUE_FILE column (type CLOB) of the SDO_COORD_OP_PARAM_VALS table (described in Section 6.7.5). The OSTN02_OSGM02_GB.txt file contains the offset matrix on which EPSG transformation method 9633 is based.

Follow these steps:

1. Download the following file:
http://www.ordnancesurvey.co.uk/oswebsite/gps/docs/OSTN02_OSGM02files.zip
2. From the OSTN02_OSGM02files.zip file, extract the following file: OSTN02_OSGM02_GB.txt
3. Edit your copy of OSTN02_OSGM02_GB.txt, and insert the following lines before the first line of the current file:

```

SDO Header
x: 0.0 - 700000.0
y: 0.0 - 1250000.0
x-intervals: 1000.0
y-intervals: 1000.0
End of SDO Header

```

The is, after the editing operation, the contents of the file will look like this:

```

SDO Header
x: 0.0 - 700000.0
y: 0.0 - 1250000.0
x-intervals: 1000.0
y-intervals: 1000.0

```

```

End of SDO Header
1,0,0,0.000,0.000,0.000,0
2,1000,0,0.000,0.000,0.000,0
3,2000,0,0.000,0.000,0.000,0
4,3000,0,0.000,0.000,0.000,0
5,4000,0,0.000,0.000,0.000,0
. . .
876949,698000,1250000,0.000,0.000,0.000,0
876950,699000,1250000,0.000,0.000,0.000,0
876951,700000,1250000,0.000,0.000,0.000,0

```

4. Save the edited file, perhaps using a different name (for example, my_OSTN02_OSGM02_GB.txt).
5. In the SDO_COORD_OP_PARAM_VALS table, for each operation of EPSG method 9633 that has PARAM_VALUE_FILE_REF value OSTN02_OSGM02_GB.TXT, update the PARAM_VALUE_FILE column to be the contents of the saved file (for example, the contents of my_OSTN02_OSGM02_GB.txt). You can use coding similar to that in [Example 6-16](#).

Example 6-16 Using British Grid Transformation OSTN02/OSGM02 (EPSG Method 9633)

```

DECLARE
ORCL_HOME_DIR VARCHAR2(128);
ORCL_WORK_DIR VARCHAR2(128);
Src_loc        BFILE;
Dest_loc       CLOB;
CURSOR PARAM_FILES IS
SELECT
COORD_OP_ID,
PARAMETER_ID,
PARAM_VALUE_FILE_REF
FROM
MDSYS.SDO_COORD_OP_PARAM_VALS
WHERE
PARAMETER_ID IN (8656, 8657, 8658, 8664, 8666)
order by
COORD_OP_ID,
PARAMETER_ID;
PARAM_FILE PARAM_FILES%ROWTYPE;
ACTUAL_FILE_NAME VARCHAR2(128);
platform NUMBER;
BEGIN
EXECUTE IMMEDIATE 'CREATE OR REPLACE DIRECTORY work_dir AS '' || system.geor_
dir || ''';

FOR PARAM_FILE IN PARAM_FILES LOOP
CASE UPPER(PARAM_FILE.PARAM_VALUE_FILE_REF)
/* NTV2 */
WHEN 'NTV2_0.GSB' THEN ACTUAL_FILE_NAME := 'ntv20.gsa';
/* GEOID03 */
WHEN 'G2003H01.ASC' THEN ACTUAL_FILE_NAME := 'g2003h01.asc';
/* British Ordnance Survey (9633) */
WHEN 'OSTN02_OSGM02_GB.TXT'
THEN ACTUAL_FILE_NAME := 'my_OSTN02_OSGM02_GB.txt';
ELSE
ACTUAL_FILE_NAME := NULL;
END CASE;

IF (NOT (ACTUAL_FILE_NAME IS NULL)) THEN
BEGIN
dbms_output.put_line('Loading file ' || actual_file_name || '...');

```

```

Src_loc := BFILENAME('WORK_DIR', ACTUAL_FILE_NAME);
DBMS_LOB.OPEN(Src_loc, DBMS_LOB.LOB_READONLY);
END;

UPDATE
  MDSYS.SDO_COORD_OP_PARAM_VALS
SET
  PARAM_VALUE_FILE = EMPTY_CLOB()
WHERE
  COORD_OP_ID = PARAM_FILE.COORD_OP_ID AND
  PARAMETER_ID = PARAM_FILE.PARAMETER_ID
RETURNING
  PARAM_VALUE_FILE INTO Dest_loc;

DBMS_LOB.OPEN(Dest_loc, DBMS_LOB.LOB_READWRITE);
DBMS_LOB.LOADFROMFILE(Dest_loc, Src_loc, DBMS_LOB.LOBMAXSIZE);
DBMS_LOB.CLOSE(Dest_loc);
DBMS_LOB.CLOSE(Src_loc);
DBMS_LOB.FILECLOSE(Src_loc);
END IF;
END LOOP;
END;
/

```

Note that adding "header" information to a grid file is required only for British Grid Transformation OSTN02/OSGM02. It is not required for NADCON, NTV2, or VERTCON matrixes, because they already have headers of varying formats.

See also the following for related information:

- [Section 6.9.2, "Creating a Projected CRS"](#)
- [Section 6.9.6, "Creating a Transformation Operation"](#)

6.10 Notes and Restrictions with Coordinate Systems Support

The following notes and restrictions apply to coordinate systems support in the current release of Oracle Spatial.

If you have geodetic data, see [Section 6.2](#) for additional considerations, guidelines, and restrictions.

6.10.1 Different Coordinate Systems for Geometries with Operators and Functions

For Spatial operators (described in [Chapter 19](#)) that take two geometries as input parameters, if the geometries are based on different coordinate systems, the query window (the second geometry) is transformed to the coordinate system of the first geometry before the operation is performed. This transformation is a temporary internal operation performed by Spatial; it does not affect any stored query-window geometry.

For SDO_GEOM package geometry functions (described in [Chapter 24](#)) that take two geometries as input parameters, both geometries must be based on the same coordinate system.

6.10.2 3D LRS Functions Not Supported with Geodetic Data

In the current release, the 3D formats of LRS functions (explained in [Section 7.4](#)) are not supported with geodetic data.

6.10.3 Functions Supported by Approximations with Geodetic Data

In the current release, the following functions are supported by approximations with geodetic data:

- [SDO_GEOM.SDO_BUFFER](#)
- [SDO_GEOM.SDO_CENTROID](#)
- [SDO_GEOM.SDO_CONVEXHULL](#)

When these functions are used on data with geodetic coordinates, they internally perform the operations in an implicitly generated local-tangent-plane Cartesian coordinate system and then transform the results to the geodetic coordinate system. For [SDO_GEOM.SDO_BUFFER](#), generated arcs are approximated by line segments before the back-transform.

6.10.4 Unknown CRS and NaC Coordinate Reference Systems

The following coordinate reference systems are provided for Oracle internal use and for other possible special uses:

- `unknown CRS` (SRID 999999) means that the coordinate system is unknown, and its space could be geodetic or Cartesian. Contrast this with specifying a null coordinate reference system, which indicates an unknown coordinate system with a Cartesian space.
- `NaC` (SRID 999998) means *Not-a-CRS*. Its name is patterned after the `NaN` (*Not-a-Number*) value in Java. It is intended for potential use with nonspatial geometries.

The following restrictions apply to geometries based on the `unknown CRS` and `NaC` coordinate reference systems:

- You cannot perform coordinate system transformations on these geometries.
- Operations that require a coordinate system will return a null value when performed on these geometries. These operations include finding the area or perimeter of a geometry, creating a buffer, densifying an arc, and computing the aggregate centroid.

6.11 U.S. National Grid Support

The U.S. National Grid is a point coordinate representation using a single alphanumeric coordinate (for example, 18SUJ2348316806479498). This approach contrasts with the use of numeric coordinates to represent the location of a point, as is done with Oracle Spatial and EPSG. A good description of the U.S. National Grid is available at <http://www.ngs.noaa.gov/TOOLS/usng.html>.

To support the U.S. National Grid in Spatial, the `SDO_GEOMETRY` type cannot be used because it is based on numeric coordinates. Instead, a point in U.S. National Grid format is represented as a single string of type `VARCHAR2`. To allow conversion between the `SDO_GEOMETRY` format and the U.S. National grid format, the `SDO_CS` package (documented in [Chapter 21](#)) contains the following functions:

- [SDO_CS.FROM_USNG](#)
- [SDO_CS.TO_USNG](#)

6.12 Google Maps Considerations

Google Maps uses spherical math in its projections, as opposed to the ellipsoidal math used by Oracle Spatial. This difference can lead to inconsistencies in applications, such as when overlaying a map based on Google Maps with a map based on an Oracle Spatial ellipsoidal projection. For example, an Oracle Spatial transformation from the ellipsoidal SRID 8307 to the spherical SRID 3785 accounts, by default, for the different ellipsoidal shapes, whereas Google Maps does not consider ellipsoidal shapes.

If you want Oracle Spatial to accommodate the Google Maps results, consider the following options:

- Use the spherical SRID 4055 instead of the ellipsoidal SRID 8307. This may be the simplest approach; however, if you need to accommodate SRID 8307-based data (such as from a third-party tool) as if it were spherical, you must use another option.
- Use SRID 3857 instead of SRID 3785. This more convenient than the next two options, because using SRID 3857 does not require that you declare an EPSG rule or that you specify the `USE_SPHERICAL` use case name in order to produce Google-compatible results.
- Declare an EPSG rule between the ellipsoidal and spherical coordinate systems. For example, declare an EPSG rule between SRIDs 8307 and 3785, ignoring the ellipsoidal shape of SRID 8307, as in the following example:

```
CALL sdo_cs.create_pref_concatenated_op(
  302,
  'CONCATENATED OPERATION',
  TFM_PLAN(SDO_TFM_CHAIN(8307, 1000000000, 4055, 19847, 3785)),
  NULL);
```

In this example, operation 1000000000 represents *no-operation*, causing the datum transformation between ellipsoid and sphere to be ignored.

With this approach, you must declare a rule for each desired SRID pair (ellipsoidal and spherical).

- Specify a use case name of `USE_SPHERICAL` with the `SDO_CS.TRANSFORM` function or the `SDO_CS.TRANSFORM_LAYER` procedure, as in the following examples:

```
SELECT
  SDO_CS.TRANSFORM(
    sdo_geometry(
      2001,
      4326,
      sdo_point_type(1, 1, null),
      null,
      null),
    'USE_SPHERICAL',
    3785)
FROM DUAL;
```

```
CALL SDO_CS.TRANSFORM_LAYER(
  'source_geoms',
  'GEOMETRY',
  'GEO_CS_3785_SPHERICAL',
  'USE_SPHERICAL',
  3785);
```

If you specify a `use_case` parameter value of `USE_SPHERICAL` in such cases, the transformation defaults to using spherical math instead of ellipsoidal math, thereby accommodating Google Maps and some other third-party tools that use spherical math.

If you use this approach (specifying `'USE_SPHERICAL'`) but you have also declared an EPSG rule requiring that ellipsoidal math be used in transformations between two specified SRIDs, then the declared EPSG rule takes precedence and ellipsoidal math is used for transformations between those two SRIDs.

6.13 Example of Coordinate System Transformation

This section presents a simplified example that uses coordinate system transformation functions and procedures. It refers to concepts that are explained in this chapter and uses functions documented in [Chapter 21](#).

[Example 6-17](#) uses mostly the same geometry data (cola markets) as in [Section 2.1](#), except that instead of null `SDO_SRID` values, the `SDO_SRID` value 8307 is used. That is, the geometries are defined as using the coordinate system whose SRID is 8307 and whose well-known name is "Longitude / Latitude (WGS 84)". This is probably the most widely used coordinate system, and it is the one used for global positioning system (GPS) devices. The geometries are then transformed using the coordinate system whose SRID is 8199 and whose well-known name is "Longitude / Latitude (Arc 1950)".

[Example 6-17](#) uses the geometries illustrated in [Figure 2-1](#) in [Section 2.1](#), except that `cola_d` is a rectangle (here, a square) instead of a circle, because arcs are not supported with geodetic coordinate systems.

[Example 6-17](#) does the following:

- Creates a table (`COLA_MARKETS_CS`) to hold the spatial data
- Inserts rows for four areas of interest (`cola_a`, `cola_b`, `cola_c`, `cola_d`), using the `SDO_SRID` value 8307
- Updates the `USER_SDO_GEOM_METADATA` view to reflect the dimension of the areas, using the `SDO_SRID` value 8307
- Creates a spatial index (`COLA_SPATIAL_IDX_CS`)
- Performs some transformation operations (single geometry and entire layer)

[Example 6-18](#) includes the output of the SELECT statements in [Example 6-17](#).

Example 6-17 Simplified Example of Coordinate System Transformation

```
-- Create a table for cola (soft drink) markets in a
-- given geography (such as city or state).

CREATE TABLE cola_markets_cs (
  mkt_id NUMBER PRIMARY KEY,
  name VARCHAR2(32),
  shape SDO_GEOMETRY);

-- The next INSERT statement creates an area of interest for
-- Cola A. This area happens to be a rectangle.
-- The area could represent any user-defined criterion: for
-- example, where Cola A is the preferred drink, where
-- Cola A is under competitive pressure, where Cola A
-- has strong growth potential, and so on.
```



```

INSERT INTO cola_markets_cs VALUES(
  1,
  'cola_a',
  SDO_GEOMETRY(
    2003, -- two-dimensional polygon
    8307, -- SRID for 'Longitude / Latitude (WGS 84)' coordinate system
    NULL,
    SDO_ELEM_INFO_ARRAY(1,1003,1), -- polygon
    SDO_ORDINATE_ARRAY(1,1, 5,1, 5,7, 1,7, 1,1) -- All vertices must
      -- be defined for rectangle with geodetic data.
  )
);

-- The next two INSERT statements create areas of interest for
-- Cola B and Cola C. These areas are simple polygons (but not
-- rectangles).

INSERT INTO cola_markets_cs VALUES(
  2,
  'cola_b',
  SDO_GEOMETRY(
    2003, -- two-dimensional polygon
    8307,
    NULL,
    SDO_ELEM_INFO_ARRAY(1,1003,1), -- one polygon (exterior polygon ring)
    SDO_ORDINATE_ARRAY(5,1, 8,1, 8,6, 5,7, 5,1)
  )
);

INSERT INTO cola_markets_cs VALUES(
  3,
  'cola_c',
  SDO_GEOMETRY(
    2003, -- two-dimensional polygon
    8307,
    NULL,
    SDO_ELEM_INFO_ARRAY(1,1003,1), --one polygon (exterior polygon ring)
    SDO_ORDINATE_ARRAY(3,3, 6,3, 6,5, 4,5, 3,3)
  )
);

-- Insert a rectangle (here, square) instead of a circle as in the original,
-- because arcs are not supported with geodetic coordinate systems.
INSERT INTO cola_markets_cs VALUES(
  4,
  'cola_d',
  SDO_GEOMETRY(
    2003, -- two-dimensional polygon
    8307, -- SRID for 'Longitude / Latitude (WGS 84)' coordinate system
    NULL,
    SDO_ELEM_INFO_ARRAY(1,1003,1), -- polygon
    SDO_ORDINATE_ARRAY(10,9, 11,9, 11,10, 10,10, 10,9) -- All vertices must
      -- be defined for rectangle with geodetic data.
  )
);

-----
-- UPDATE METADATA VIEW --
-----
-- Update the USER_SDO_GEOM_METADATA view. This is required

```

```

-- before the Spatial index can be created. Do this only once for each
-- layer (table-column combination; here: cola_markets_cs and shape).

INSERT INTO user_sdo_geom_metadata
  (TABLE_NAME,
   COLUMN_NAME,
   DIMINFO,
   SRID)
VALUES (
  'cola_markets_cs',
  'shape',
  SDO_DIM_ARRAY(
    SDO_DIM_ELEMENT('Longitude', -180, 180, 10), -- 10 meters tolerance
    SDO_DIM_ELEMENT('Latitude', -90, 90, 10) -- 10 meters tolerance
  ),
  8307 -- SRID for 'Longitude / Latitude (WGS 84)' coordinate system
);

-----
-- CREATE THE SPATIAL INDEX --
-----

CREATE INDEX cola_spatial_idx_cs
ON cola_markets_cs(shape)
INDEXTYPE IS MDSYS.SPATIAL_INDEX;

-----
-- TEST COORDINATE SYSTEM TRANSFORMATION --
-----

-- Return the transformation of cola_c using to_srid 8199
-- ('Longitude / Latitude (Arc 1950)')
SELECT c.name, SDO_CS.TRANSFORM(c.shape, 8199)
  FROM cola_markets_cs c WHERE c.name = 'cola_c';

-- Same as preceding, but using to_sname parameter.
SELECT c.name, SDO_CS.TRANSFORM(c.shape, 'Longitude / Latitude (Arc 1950)')
  FROM cola_markets_cs c WHERE c.name = 'cola_c';

-- Transform the entire SHAPE layer and put results in the table
-- named cola_markets_cs_8199, which the procedure will create.
CALL SDO_CS.TRANSFORM_LAYER('COLA_MARKETS_CS', 'SHAPE', 'COLA_MARKETS_CS_
8199', 8199);

-- Select all from the old (existing) table.
SELECT * from cola_markets_cs;

-- Select all from the new (layer transformed) table.
SELECT * from cola_markets_cs_8199;

-- Show metadata for the new (layer transformed) table.
DESCRIBE cola_markets_cs_8199;

-- Use a geodetic MBR with SDO_FILTER.
SELECT c.name FROM cola_markets_cs c WHERE
  SDO_FILTER(c.shape,
    SDO_GEOMETRY(
      2003,
      8307, -- SRID for WGS 84 longitude/latitude
      NULL,
      SDO_ELEM_INFO_ARRAY(1,1003,3),

```

```
        SDO_ORDINATE_ARRAY(6,5, 10,10))
    ) = 'TRUE';
```

Example 6–18 shows the output of the SELECT statements in **Example 6–17**. Notice the slight differences between the coordinates in the original geometries (SRID 8307) and the transformed coordinates (SRID 8199) -- for example, (1, 1, 5, 1, 5, 7, 1, 7, 1, 1) and (1.00078604, 1.00274579, 5.00069354, 1.00274488, 5.0006986, 7.00323528, 1.00079179, 7.00324162, 1.00078604, 1.00274579) for cola_a.

Example 6–18 Output of SELECT Statements in Coordinate System Transformation Example

```
SQL> -- Return the transformation of cola_c using to_srid 8199
SQL> -- ('Longitude / Latitude (Arc 1950)')
SQL> SELECT c.name, SDO_CS.TRANSFORM(c.shape, 8199)
      2 FROM cola_markets_cs c WHERE c.name = 'cola_c';
```

```
NAME
-----
SDO_CS.TRANSFORM(C.SHAPE,8199)(SDO_GTYPE, SDO_SRID, SDO_POINT(X, Y, Z), SDO_ELEM
-----
cola_c
SDO_GEOMETRY(2003, 8199, NULL, SDO_ELEM_INFO_ARRAY(1, 1003, 1), SDO_ORDINATE_ARR
AY(3.00074114, 3.00291482, 6.00067068, 3.00291287, 6.0006723, 5.00307625, 4.0007
1961, 5.00307838, 3.00074114, 3.00291482))
```

```
SQL>
SQL> -- Same as preceding, but using to_sname parameter.
SQL> SELECT c.name, SDO_CS.TRANSFORM(c.shape, 'Longitude / Latitude (Arc 1950)')
      2 FROM cola_markets_cs c WHERE c.name = 'cola_c';
```

```
NAME
-----
SDO_CS.TRANSFORM(C.SHAPE,'LONGITUDE/LATITUDE(ARC1950)')(SDO_GTYPE, SDO_SRID, SDO
-----
cola_c
SDO_GEOMETRY(2003, 8199, NULL, SDO_ELEM_INFO_ARRAY(1, 1003, 1), SDO_ORDINATE_ARR
AY(3.00074114, 3.00291482, 6.00067068, 3.00291287, 6.0006723, 5.00307625, 4.0007
1961, 5.00307838, 3.00074114, 3.00291482))
```

```
SQL>
SQL> -- Transform the entire SHAPE layer and put results in the table
SQL> -- named cola_markets_cs_8199, which the procedure will create.
SQL> CALL SDO_CS.TRANSFORM_LAYER('COLA_MARKETS_CS','SHAPE','COLA_MARKETS_CS_
8199',8199);
```

Call completed.

```
SQL>
SQL> -- Select all from the old (existing) table.
SQL> SELECT * from cola_markets_cs;
```

```
      MKT_ID NAME
-----
SHAPE(SDO_GTYPE, SDO_SRID, SDO_POINT(X, Y, Z), SDO_ELEM_INFO, SDO_ORDINATES)
-----
      1 cola_a
SDO_GEOMETRY(2003, 8307, NULL, SDO_ELEM_INFO_ARRAY(1, 1003, 1), SDO_ORDINATE_ARR
AY(1, 1, 5, 1, 5, 7, 1, 7, 1, 1))
```

```

                2 cola_b
SDO_GEOMETRY(2003, 8307, NULL, SDO_ELEM_INFO_ARRAY(1, 1003, 1), SDO_ORDINATE_ARR
AY(5, 1, 8, 1, 8, 6, 5, 7, 5, 1))

```

```

                3 cola_c

```

```

                MKT_ID NAME
-----
SHAPE(SDO_GTYPE, SDO_SRID, SDO_POINT(X, Y, Z), SDO_ELEM_INFO, SDO_ORDINATES)
-----
SDO_GEOMETRY(2003, 8307, NULL, SDO_ELEM_INFO_ARRAY(1, 1003, 1), SDO_ORDINATE_ARR
AY(3, 3, 6, 3, 6, 5, 4, 5, 3, 3))

```

```

                4 cola_d
SDO_GEOMETRY(2003, 8307, NULL, SDO_ELEM_INFO_ARRAY(1, 1003, 1), SDO_ORDINATE_ARR
AY(10, 9, 11, 9, 11, 10, 10, 10, 10, 9))

```

```

SQL>
SQL> -- Select all from the new (layer transformed) table.
SQL> SELECT * from cola_markets_cs_8199;

```

```

SDO_ROWID
-----
GEOMETRY(SDO_GTYPE, SDO_SRID, SDO_POINT(X, Y, Z), SDO_ELEM_INFO, SDO_ORDINATES)
-----
AAABZzAABAAA0a6AAA
SDO_GEOMETRY(2003, 8199, NULL, SDO_ELEM_INFO_ARRAY(1, 1003, 1), SDO_ORDINATE_ARR
AY(1.00078604, 1.00274579, 5.00069354, 1.00274488, 5.0006986, 7.00323528, 1.0007
9179, 7.00324162, 1.00078604, 1.00274579))

```

```

AAABZzAABAAA0a6AAB
SDO_GEOMETRY(2003, 8199, NULL, SDO_ELEM_INFO_ARRAY(1, 1003, 1), SDO_ORDINATE_ARR
AY(5.00069354, 1.00274488, 8.00062191, 1.00274427, 8.00062522, 6.00315345, 5.000
6986, 7.00323528, 5.00069354, 1.00274488))

```

```

SDO_ROWID
-----
GEOMETRY(SDO_GTYPE, SDO_SRID, SDO_POINT(X, Y, Z), SDO_ELEM_INFO, SDO_ORDINATES)
-----
AAABZzAABAAA0a6AAC
SDO_GEOMETRY(2003, 8199, NULL, SDO_ELEM_INFO_ARRAY(1, 1003, 1), SDO_ORDINATE_ARR
AY(3.00074114, 3.00291482, 6.00067068, 3.00291287, 6.0006723, 5.00307625, 4.0007
1961, 5.00307838, 3.00074114, 3.00291482))

```

```

AAABZzAABAAA0a6AAD
SDO_GEOMETRY(2003, 8199, NULL, SDO_ELEM_INFO_ARRAY(1, 1003, 1), SDO_ORDINATE_ARR
AY(10.0005802, 9.00337775, 11.0005553, 9.00337621, 11.0005569, 10.0034478, 10.00
05819, 10.0034495, 10.0005802, 9.00337775))

```

```

SQL>
SQL> -- Show metadata for the new (layer transformed) table.
SQL> DESCRIBE cola_markets_cs_8199;

```

Name	Null?	Type
SDO_ROWID		ROWID
GEOMETRY		SDO_GEOMETRY

SQL>

SQL> -- Use a geodetic MBR with SDO_FILTER

SQL> SELECT c.name FROM cola_markets_cs c WHERE

```

2     SDO_FILTER(c.shape,
3         SDO_GEOMETRY(
4             2003,
5             8307,      -- SRID for WGS 84 longitude/latitude
6             NULL,
7             SDO_ELEM_INFO_ARRAY(1,1003,3),
8             SDO_ORDINATE_ARRAY(6,5, 10,10))
9     ) = 'TRUE';

```

NAME

```

-----
cola_c
cola_b
cola_d

```

Linear Referencing System

Linear referencing is a natural and convenient means to associate attributes or events to locations or portions of a linear feature. It has been widely used in transportation applications (such as for highways, railroads, and transit routes) and utilities applications (such as for gas and oil pipelines). The major advantage of linear referencing is its capability of locating attributes and events along a linear feature with only one parameter (usually known as *measure*) instead of two (such as *longitude/latitude* or *x/y* in Cartesian space). Sections of a linear feature can be referenced and created dynamically by indicating the start and end locations along the feature without explicitly storing them.

The linear referencing system (LRS) application programming interface (API) in Oracle Spatial provides server-side LRS capabilities at the cartographic level. The linear measure information is directly integrated into the Oracle Spatial geometry structure. The Oracle Spatial LRS API provides support for dynamic segmentation, and it serves as a groundwork for third-party or middle-tier application development for virtually any linear referencing methods and models in any coordinate system.

For an example of LRS, see [Section 7.7](#). However, you may want to read the rest of this chapter first, to understand the concepts that the example illustrates.

For reference information about LRS functions and procedures, see [Chapter 25](#).

This chapter contains the following major sections:

- [Section 7.1, "Terms and Concepts"](#)
- [Section 7.2, "LRS Data Model"](#)
- [Section 7.3, "Indexing of LRS Data"](#)
- [Section 7.4, "3D Formats of LRS Functions"](#)
- [Section 7.5, "LRS Operations"](#)
- [Section 7.6, "Tolerance Values with LRS Functions"](#)
- [Section 7.7, "Example of LRS Functions"](#)

7.1 Terms and Concepts

This section explains important terms and concepts related to linear referencing support in Oracle Spatial.

7.1.1 Geometric Segments (LRS Segments)

Geometric segments are basic LRS elements in Oracle Spatial. A geometric segment can be any of the following:

- Line string: an ordered, nonbranching, and continuous geometry (for example, a simple road)
- Multiline string: nonconnected line strings (for example, a highway with a gap caused by a lake or a bypass road)
- Polygon (for example, a racetrack or a scenic tour route that starts and ends at the same point)

A geometric segment must contain at least start and end measures for its start and end points. Measures of points of interest (such as highway exits) on the geometric segments can also be assigned. These measures are either assigned by users or derived from existing geometric segments. Figure 7-1 shows a geometric segment with four line segments and one arc. Points on the geometric segment are represented by triplets (x, y, m) , where x and y describe the location and m denotes the measure (with each measure value underlined in Figure 7-1).

Figure 7-1 Geometric Segment

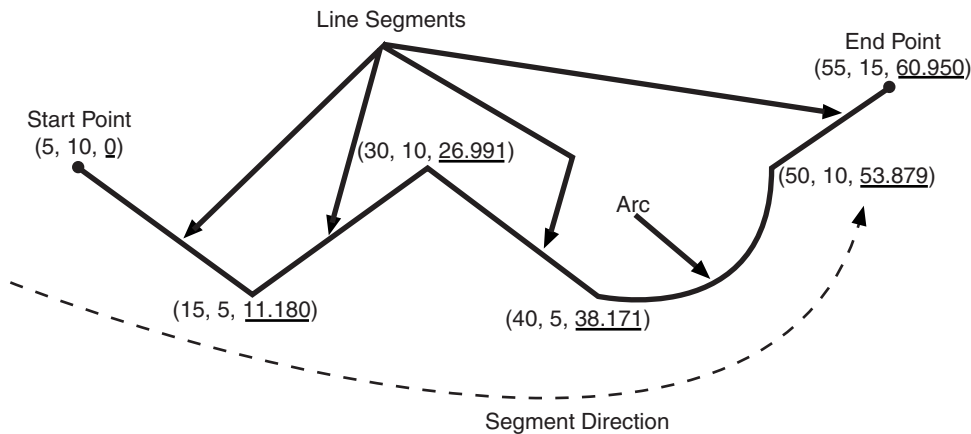

7.1.2 Shape Points

Shape points are points that are specified when an LRS segment is constructed, and that are assigned measure information. In Oracle Spatial, a line segment is represented by its start and end points, and an arc is represented by three points: start, middle, and end points of the arc. You must specify these points as shape points, but you can also specify other points as shape points if you need measure information stored for these points (for example, an exit in the middle of a straight part of the highway).

Thus, shape points can serve one or both of the following purposes: to indicate the direction of the segment (for example, a turn or curve), and to identify a point of interest for which measure information is to be stored.

Shape points might not directly relate to mileposts or reference posts in LRS; they are used as internal reference points. The measure information of shape points is automatically populated when you define the LRS segment using the [SDO_LRS.DEFINE_GEOM_SEGMENT](#) procedure, which is described in [Chapter 25](#).

7.1.3 Direction of a Geometric Segment

The **direction** of a geometric segment is indicated from the start point of the geometric segment to the end point. The direction is determined by the order of the vertices (from start point to end point) in the geometry definition. Measures of points on a

geometric segment always either increase or decrease along the direction of the geometric segment.

7.1.4 Measure (Linear Measure)

The **measure** of a point along a geometric segment is the linear distance (in the measure dimension) to the point measured from the start point (for increasing values) or end point (for decreasing values) of the geometric segment. The measure information does not necessarily have to be of the same scale as the distance. However, the linear mapping relationship between measure and distance is always preserved.

Some LRS functions use *offset* instead of measure to represent measured distance along linear features. Although some other linear referencing systems might use offset to mean what the Oracle Spatial LRS refers to as measure, offset has a different meaning in Oracle Spatial from measure, as explained in [Section 7.1.5](#).

7.1.5 Offset

The **offset** of a point along a geometric segment is the perpendicular distance between the point and the geometric segment. Offsets are positive if the points are on the left side along the segment direction and are negative if they are on the right side. Points are on a geometric segment if their offsets to the segment are zero.

The unit of measurement for an offset is the same as for the coordinate system associated with the geometric segment. For geodetic data, the default unit of measurement is meters.

[Figure 7-2](#) shows how a point can be located along a geometric segment with measure and offset information. By assigning an offset together with a measure, it is possible to locate not only points that are on the geometric segment, but also points that are perpendicular to the geometric segment.

Figure 7-2 Describing a Point Along a Segment with a Measure and an Offset

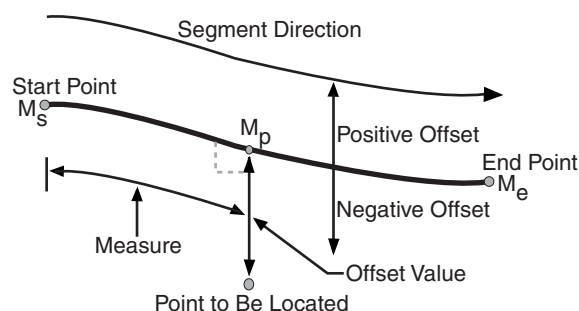

7.1.6 Measure Populating

Any unassigned measures of a geometric segment are automatically populated based upon their distance distribution. This is done before any LRS operations for geometric segments with unknown measures (NULL in Oracle Spatial). The resulting geometric segments from any LRS operations return the measure information associated with geometric segments. The measure of a point on the geometric segment can be obtained based upon a linear mapping relationship between its previous and next known measures or locations. See the algorithm representation in [Figure 7-3](#) and the example in [Figure 7-4](#).

Figure 7-3 Measures, Distances, and Their Mapping Relationship

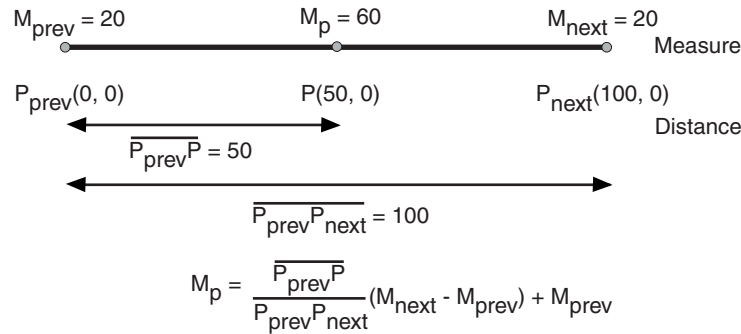
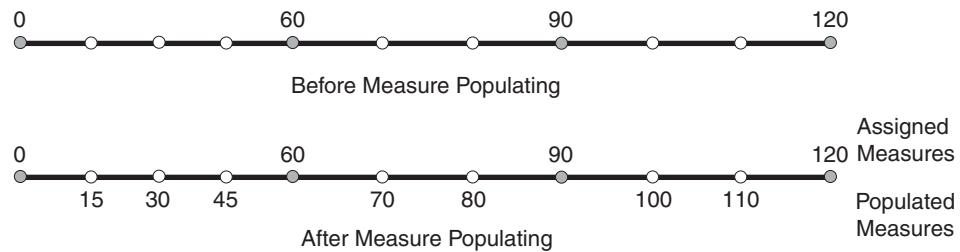

Figure 7-4 Measure Populating of a Geometric Segment



Measures are evenly spaced between assigned measures. However, the assigned measures for points of interest on a geometric segment do not need to be evenly spaced. This could eliminate the problem of error accumulation and account for inaccuracy of data source.

Moreover, the assigned measures do not even need to reflect actual distances (for example, they can reflect estimated driving time); they can be any valid values within the measure range. Figure 7-5 shows the measure population that results when assigned measure values are not proportional and reflect widely varying gaps.

Figure 7-5 Measure Populating with Disproportional Assigned Measures

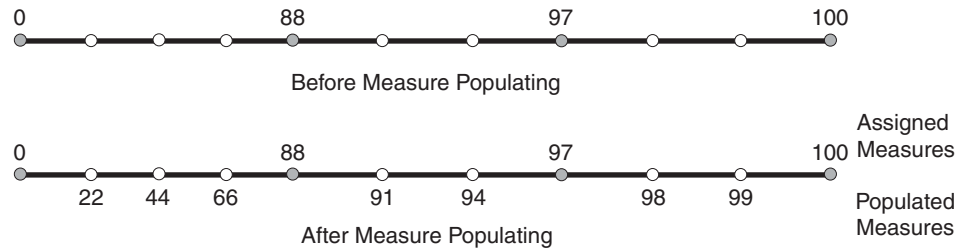

In all cases, measure populating is done in an incremental fashion along the segment direction. This improves the performance of current and subsequent LRS operations.

7.1.7 Measure Range of a Geometric Segment

The start and end measures of a geometric segment define the linear **measure range** of the geometric segment. Any valid LRS measures of a geometric segment must fall within its linear measure range.

7.1.8 Projection

The **projection** of a point along a geometric segment is the point on the geometric segment with the minimum distance to the specified point. The measure information of the resulting point is also returned in the point geometry.

7.1.9 LRS Point

LRS points are points with linear measure information along a geometric segment. A valid LRS point is a point geometry with measure information.

All LRS point data must be stored in the SDO_ELEM_INFO_ARRAY and SDO_ORDINATE_ARRAY, and cannot be stored in the SDO_POINT field in the SDO_GEOMETRY definition of the point.

7.1.10 Linear Features

Linear features are any spatial objects that can be treated as a logical set of linear segments. Examples of linear features are highways in transportation applications and pipelines in utility industry applications. The relationship of linear features, geometric segments, and LRS points is shown in [Figure 7-6](#), where a single linear feature consists of three geometric segments, and three LRS points are shown on the first segment.

Figure 7-6 Linear Feature, Geometric Segments, and LRS Points

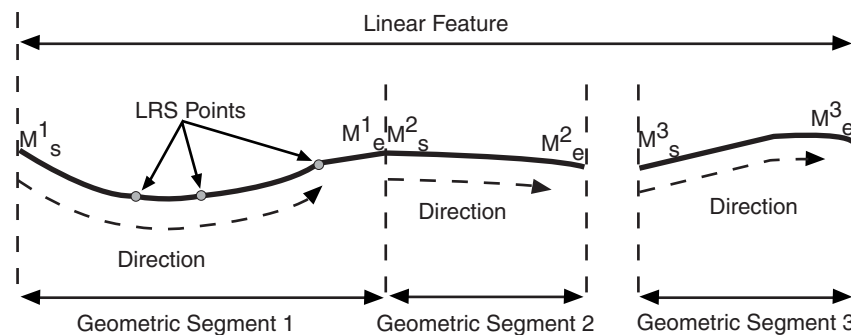

7.1.11 Measures with Multiline Strings and Polygons with Holes

With a multiline string or polygon with hole LRS geometry, the [SDO_LRS.DEFINE_GEOM_SEGMENT](#) procedure and [SDO_LRS.CONVERT_TO_LRS_GEOM](#) function by default assign the same measure value to the end point of one segment and the start point (separated by a gap) of the next segment, although you can later assign different measure values to points. Thus, by default there will duplicate measure values in different segments for such geometries. In such cases, LRS subprograms use the first point with a specified measure, except when doing so would result in an invalid geometry.

For example, assume that in a multiline string LRS geometry, the first segment is from measures 0 through 100 and the second segment is from measures 100 through 150. If you use the [SDO_LRS.LOCATE_PT](#) function to find the point at measure 100, the

returned point will be at measure 100 in the first segment. If you use the [SDO_LRS.CLIP_GEOM_SEGMENT](#), [SDO_LRS.DYNAMIC_SEGMENT](#), or [SDO_LRS.OFFSET_GEOM_SEGMENT](#) function to return the geometry object between measures 75 and 125, the result is a multiline string geometry consisting of two segments. If you use the same function to return the geometry object between measures 100 and 125, the point at measure 100 in the first segment is ignored, and the result is a line string along the second segment from measures 100 through 125.

7.2 LRS Data Model

The Oracle Spatial LRS data model incorporates measure information into its geometry representation at the point level. The measure information is directly integrated into the Oracle Spatial model. To accomplish this, an additional *measure* dimension must be added to the Oracle Spatial metadata.

Oracle Spatial LRS support affects the Spatial metadata and data (the geometries). [Example 7-1](#) shows how a measure dimension can be added to two-dimensional geometries in the Spatial metadata. The measure dimension must be the last element of the `SDO_DIM_ARRAY` in a spatial object definition (shown in bold in [Example 7-1](#)).

Example 7-1 Including LRS Measure Dimension in Spatial Metadata

```
INSERT INTO user_sdo_geom_metadata
  (TABLE_NAME,
   COLUMN_NAME,
   DIMINFO,
   SRID)
VALUES (
  'LRS_ROUTES',
  'GEOMETRY',
  SDO_DIM_ARRAY (
    SDO_DIM_ELEMENT('X', 0, 20, 0.005),
    SDO_DIM_ELEMENT('Y', 0, 20, 0.005),
    SDO_DIM_ELEMENT('M', 0, 100, 0.005)),
  NULL);
```

After adding the new measure dimension, geometries with measure information such as geometric segments and LRS points can be represented. An example of creating a geometric segment with three line segments is shown in [Figure 7-7](#).

Figure 7-7 Creating a Geometric Segment

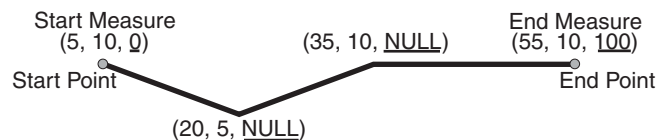

In [Figure 7-7](#), the geometric segment has the following definition (with measure values underlined):

```
SDO_GEOMETRY(3302, NULL, NULL,
  SDO_ELEM_INFO_ARRAY(1,2,1),
  SDO_ORDINATE_ARRAY(5,10,0, 20,5,NULL, 35,10,NULL, 55,10,100))
```

Whenever a geometric segment is defined, its start and end measures must be defined or derived from some existing geometric segment. The unsigned measures of all shape points on a geometric segment will be automatically populated.

The SDO_GTYPE of any point geometry used with an LRS function must be 3301.

7.3 Indexing of LRS Data

If LRS data has four dimensions (three plus the M dimension) and if you need to index all three non-measure dimensions, you must use a spatial R-tree index to index the data, and you must specify `PARAMETERS('sdo_indx_dims=3')` in the `CREATE INDEX` statement to ensure that the first three dimensions are indexed. Note, however, that if you specify an `sdo_indx_dims` value of 3 or higher, only those operators listed in [Section 1.11](#) as considering all three dimensions can be used on the indexed geometries; the other operators described in [Chapter 19](#) cannot be used. (The default value for the `sdo_indx_dims` keyword is 2, which would cause only the first two dimensions to be indexed.) For example, if the dimensions are X, Y, Z, and M, specify `sdo_indx_dims=3` to index the X, Y, and Z dimensions, but not the measure (M) dimension. Do not include the measure dimension in a spatial index, because this causes additional processing overhead and produces no benefit.

Information about the `CREATE INDEX` statement and its parameters and keywords is in [Chapter 18](#).

7.4 3D Formats of LRS Functions

Most LRS functions have formats that end in `_3D`: for example, `DEFINE_GEOM_SEGMENT_3D`, `CLIP_GEOM_SEGMENT_3D`, `FIND_MEASURE_3D`, and `LOCATE_PT_3D`. If a function has a `3D` format, it is identified in the Usage Notes for the function in [Chapter 25](#).

The `3D` formats are supported only for line string and multiline string geometries. The `3D` formats should be used only when the geometry object has four dimensions and the fourth dimension is the measure (for example, X, Y, Z, and M), and only when you want the function to consider the first three dimensions (for example, X, Y, and Z). If the standard format of a function (that is, without the `_3D`) is used on a geometry with four dimensions, the function considers only the first two dimensions (for example, X and Y).

For example, the following format considers the X, Y, and Z dimensions of the specified GEOM object in performing the clip operation:

```
SELECT SDO_LRS.CLIP_GEOM_SEGMENT_3D(a.geom, m.dinfo, 5, 10)
FROM routes r, user_sdo_geom_metadata m
WHERE m.table_name = 'ROUTES' AND m.column_name = 'GEOM'
AND r.route_id = 1;
```

However, the following format considers only the X and Y dimensions, and ignores the Z dimension, of the specified GEOM object in performing the clip operation:

```
SELECT SDO_LRS.CLIP_GEOM_SEGMENT(a.geom, m.dinfo, 5, 10)
FROM routes r, user_sdo_geom_metadata m
WHERE m.table_name = 'ROUTES' AND m.column_name = 'GEOM'
AND r.route_id = 1;
```

The parameters for the standard and `3D` formats of any function are the same, and the Usage Notes apply to both formats.

The `3D` formats are not supported with the following:

- Geodetic data
- Polygons, arcs, or circles

7.5 LRS Operations

This section describes several linear referencing operations supported by the Oracle Spatial LRS API.

7.5.1 Defining a Geometric Segment

There are two ways to create a geometric segment with measure information:

- Construct a geometric segment and assign measures explicitly.
- Define a geometric segment with specified start and end, and any other measures, in an ascending or descending order. Measures of shape points with unknown (unassigned) measures (null values) in the geometric segment will be automatically populated according to their locations and distance distribution.

Figure 7–8 shows different ways of defining a geometric segment:

Figure 7–8 Defining a Geometric Segment

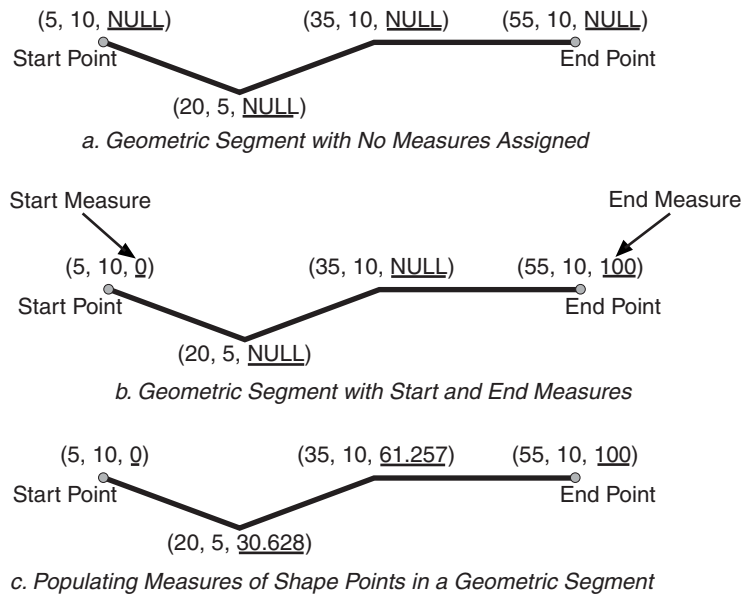

An LRS segment must be defined (or must already exist) before any LRS operations can proceed. That is, the start, end, and any other assigned measures must be present to derive the location from a specified measure. The measure information of intermediate shape points will automatically be populated if measure values are not assigned.

7.5.2 Redefining a Geometric Segment

You can redefine a geometric segment to replace the existing measures of all shape points between the start and end point with automatically calculated measures. Redefining a segment can be useful if errors have been made in one or more explicit

measure assignments, and you want to start over with proportionally assigned measures.

Figure 7-9 shows the redefinition of a segment where the existing (before) assigned measure values are not proportional and reflect widely varying gaps.

Figure 7-9 Redefining a Geometric Segment

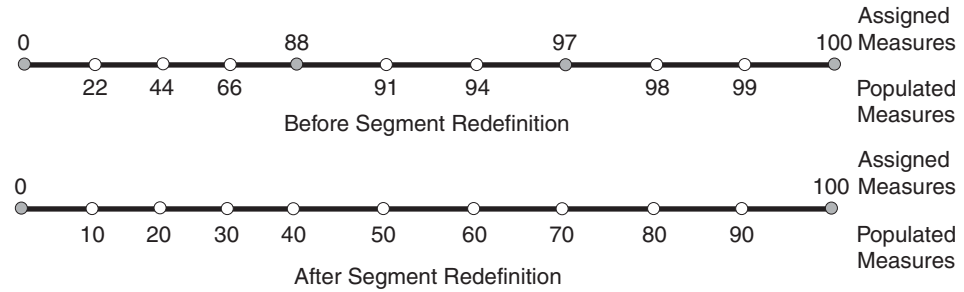

After the segment redefinition in Figure 7-9, the populated measures reflect proportional distances along the segment.

7.5.3 Clipping a Geometric Segment

You can clip a geometric segment to create a new geometric segment out of an existing geometric segment, as shown in Figure 7-10, part a.

Figure 7-10 Clipping, Splitting, and Concatenating Geometric Segments

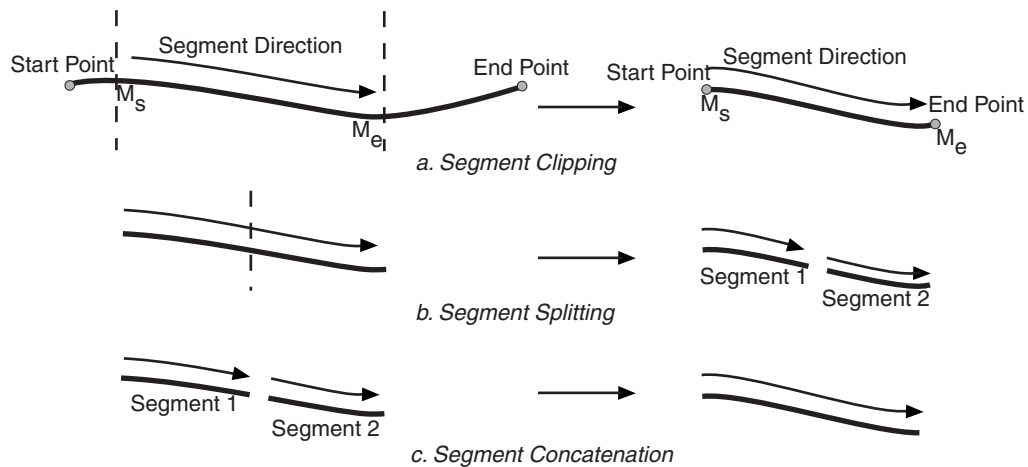

In Figure 7-10, part a, a segment is created from part of a larger segment. The new segment has its own start and end points, and the direction is the same as in the original larger segment.

7.5.4 Splitting a Geometric Segment

You can create two new geometric segments by splitting a geometric segment, as shown in Figure 7-10, part b. The direction of each new segment is the same as in the original segment.

Note: In [Figure 7–10](#) and several figures that follow, small gaps between segments are used in illustrations of segment splitting and concatenation. Each gap simply reinforces the fact that two different segments are involved. However, the two segments (such as segment 1 and segment 2 in [Figure 7–10](#), parts b and c) are actually connected. The tolerance (see [Section 1.5.5](#)) is considered in determining whether or not segments are connected.

7.5.5 Concatenating Geometric Segments

You can create a new geometric segment by concatenating two geometric segments, as shown in [Figure 7–10](#), part c. The geometric segments do not need to be spatially connected, although they are connected in the illustration in [Figure 7–10](#), part c. (If the segments are not spatially connected, the concatenated result is a multiline string.) The measures of the second geometric segment are shifted so that the end measure of the first segment is the same as the start measure of the second segment. The direction of the segment resulting from the concatenation is the same as in the two original segments.

Measure assignments for the clipping, splitting, and concatenating operations in [Figure 7–10](#) are shown in [Figure 7–11](#). Measure information and segment direction are preserved in a consistent manner. The assignment is done automatically when the operations have completed.

Figure 7–11 Measure Assignment in Geometric Segment Operations

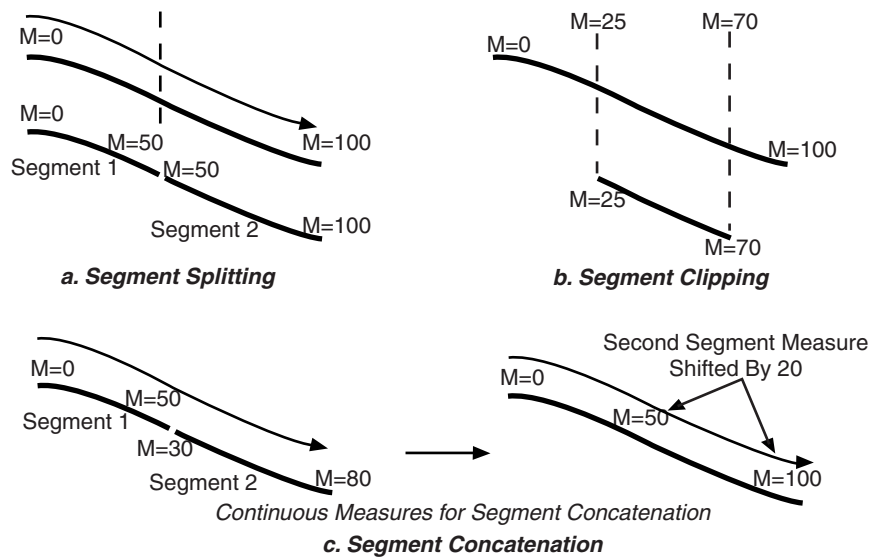

The direction of the geometric segment resulting from concatenation is always the direction of the first segment (`geom_segment1` in the call to the [SDO_LRS.CONCATENATE_GEOM_SEGMENTS](#) function), as shown in [Figure 7–12](#).

Figure 7–12 Segment Direction with Concatenation

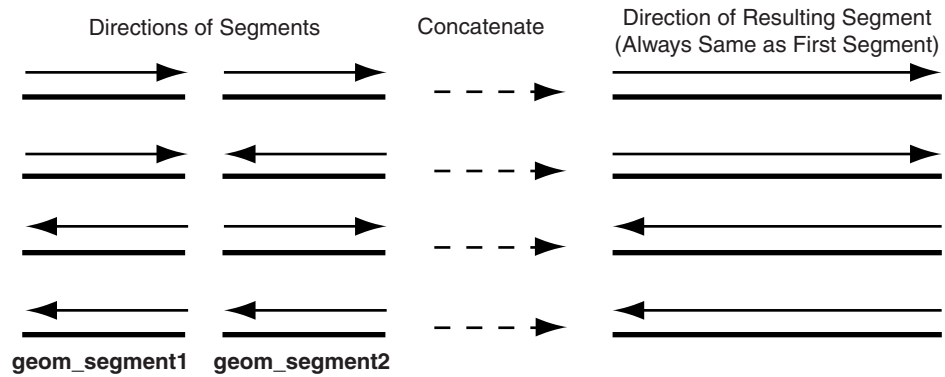

In addition to explicitly concatenating two connected segments using the [SDO_LRS.CONCATENATE_GEOM_SEGMENTS](#) function, you can perform aggregate concatenation: that is, you can concatenate all connected geometric segments in a column (layer) using the [SDO_AGGR_LRS_CONCAT](#) spatial aggregate function. (See the description and example of the [SDO_AGGR_LRS_CONCAT](#) spatial aggregate function in [Chapter 20](#).)

7.5.6 Scaling a Geometric Segment

You can create a new geometric segment by performing a linear scaling operation on a geometric segment. [Figure 7–13](#) shows the mapping relationship for geometric segment scaling.

Figure 7–13 Scaling a Geometric Segment

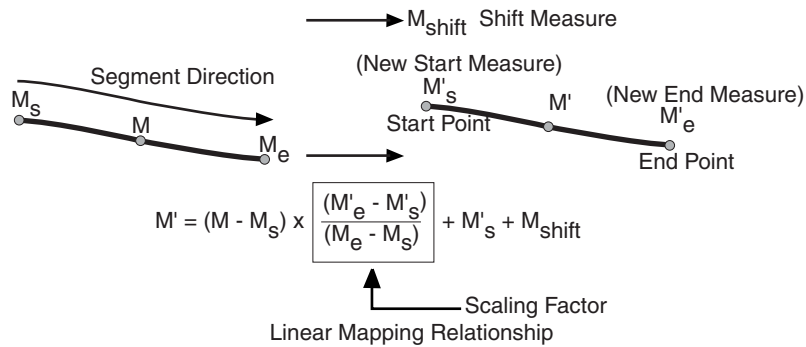

In general, scaling a geometric segment only involves rearranging measures of the newly created geometric segment. However, if the scaling factor is negative, the order of the shape points needs to be reversed so that measures will increase along the geometric segment's direction (which is defined by the order of the shape points).

A scale operation can perform any combination of the following operations:

- Translating (shifting) measure information. (For example, add the same value to Ms and Me to get M's and M'e.)
- Reversing measure information. (Let M's = Me, M'e = Ms, and Mshift = 0.)
- Performing simple scaling of measure information. (Let Mshift = 0.)

For examples of these operations, see the Usage Notes and Examples for the [SDO_LRS.SCALE_GEOM_SEGMENT](#), [SDO_LRS.TRANSLATE_MEASURE](#), [SDO_LRS.REVERSE_GEOMETRY](#), and [SDO_LRS.REDEFINE_GEOM_SEGMENT](#) subprograms in [Chapter 25](#).

7.5.7 Offsetting a Geometric Segment

You can create a new geometric segment by performing an offsetting operation on a geometric segment. [Figure 7-14](#) shows the mapping relationship for geometric segment offsetting.

Figure 7-14 Offsetting a Geometric Segment

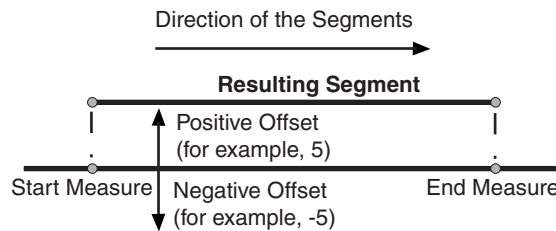

In the offsetting operation shown in [Figure 7-14](#), the resulting geometric segment is offset by 5 units from the specified start and end measures of the original segment.

For more information, see the Usage Notes and Examples for the [SDO_LRS.OFFSET_GEOM_SEGMENT](#) function in [Chapter 25](#).

7.5.8 Locating a Point on a Geometric Segment

You can find the position of a point described by a measure and an offset on a geometric segment (see [Figure 7-15](#)).

Figure 7-15 Locating a Point Along a Segment with a Measure and an Offset

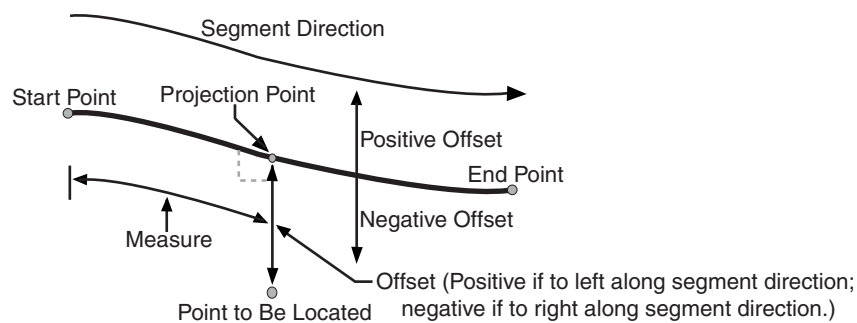

There is always a unique location with a specific measure on a geometric segment. Ambiguity arises when offsets are given and the points described by the measures fall on shape points of the geometric segment (see [Figure 7-16](#)).

Figure 7–16 Ambiguity in Location Referencing with Offsets

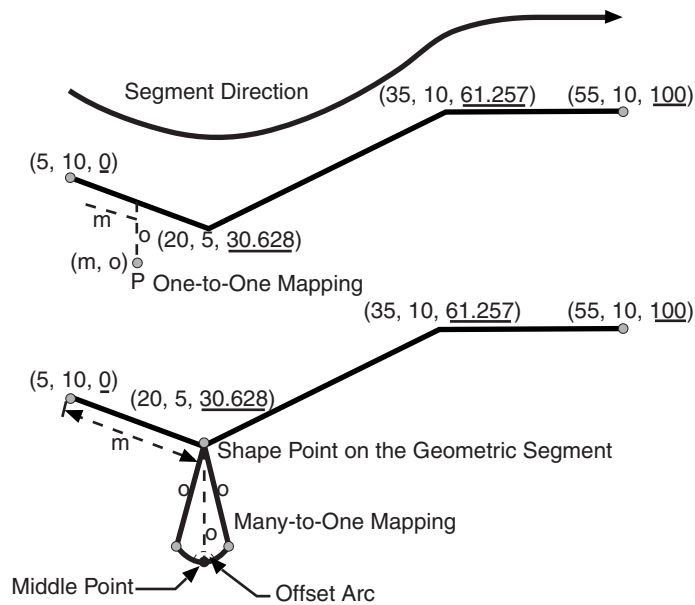

As shown in [Figure 7–16](#), an offset arc of a shape point on a geometric segment is an arc on which all points have the same minimum distance to the shape point. As a result, all points on the offset arc are represented by the same (measure, offset) pair. To resolve this one-to-many mapping problem, the middle point on the offset arc is returned.

7.5.9 Projecting a Point onto a Geometric Segment

You can find the projection point of a point with respect to a geometric segment. The point to be projected can be on or off the segment. If the point is on the segment, the point and its projection point are the same.

Projection is a reverse operation of the point-locating operation shown in [Figure 7–15](#). Similar to a point-locating operation, all points on the offset arc of a shape point will have the same projection point (that is, the shape point itself), measure, and offset (see [Figure 7–16](#)). If there are multiple projection points for a point, the first one from the start point is returned (Projection Point 1 in both illustrations in [Figure 7–17](#)).

Figure 7–17 Multiple Projection Points

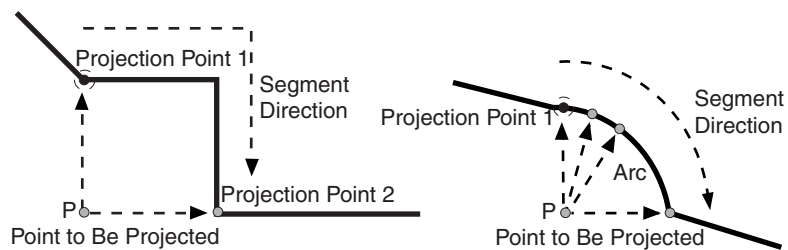

7.5.10 Converting LRS Geometries

You can convert geometries from standard line string format to LRS format, and the reverse. The main use of conversion functions will probably occur if you have a large amount of existing line string data, in which case conversion is a convenient alternative to creating all of the LRS segments manually. However, if you need to convert LRS segments to standard line strings for certain applications, that capability is provided also.

Functions are provided to convert:

- Individual line strings or points

For conversion from standard format to LRS format, a measure dimension (named *M* by default) is added, and measure information is provided for each point. For conversion from LRS format to standard format, the measure dimension and information are removed. In both cases, the dimensional information (DIMINFO) metadata in the USER_SDO_GEOM_METADATA view is not affected.

- Layers (all geometries in a column)

For conversion from standard format to LRS format, a measure dimension (named *M* by default) is added, but no measure information is provided for each point. For conversion from LRS format to standard format, the measure dimension and information are removed. In both cases, the dimensional information (DIMINFO) metadata in the USER_SDO_GEOM_METADATA view is modified as needed.

- Dimensional information (DIMINFO)

The dimensional information (DIMINFO) metadata in the USER_SDO_GEOM_METADATA view is modified as needed. For example, converting a standard dimensional array with X and Y dimensions (SDO_DIM_ELEMENT) to an LRS dimensional array causes an M dimension (SDO_DIM_ELEMENT) to be added.

Figure 7–18 shows the addition of measure information when a standard line string is converted to an LRS line string (using the `SDO_LRS.CONVERT_TO_LRS_GEOM` function). The measure dimension values are underlined in Figure 7–18.

Figure 7–18 Conversion from Standard to LRS Line String

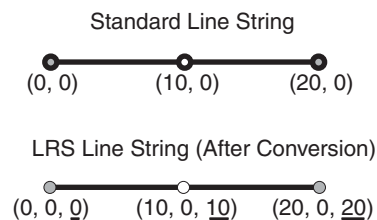

For conversions of point geometries, the SDO_POINT attribute (described in Section 2.2.3) in the returned geometry is affected as follows:

- If a standard point is converted to an LRS point, the SDO_POINT attribute information in the input geometry is used to set the SDO_ELEM_INFO and SDO_ORDINATES attributes (described in Section 2.2.4 and Section 2.2.5) in the resulting geometry, and the SDO_POINT attribute in the resulting geometry is set to null.
- If an LRS point is converted to a standard point, the information in the SDO_ELEM_INFO and SDO_ORDINATES attributes (described in Section 2.2.4 and Section 2.2.5) in the input geometry is used to set the SDO_POINT attribute

information in the resulting geometry, and the SDO_ELEM_INFO and SDO_ORDINATES attributes in the resulting geometry are set to null.

The conversion functions are listed in [Table 25–3](#) in [Chapter 25](#). See also the reference information in [Chapter 25](#) about each conversion function.

7.6 Tolerance Values with LRS Functions

Many LRS functions require that you specify a tolerance value or one or more dimensional arrays. Thus, you can control whether to specify a single tolerance value for all non-measure dimensions or to use the tolerance associated with each non-measure dimension in the dimensional array or arrays. The tolerance is applied only to the geometry portion of the data, not to the measure dimension. The tolerance value for geodetic data is in meters, and for non-geodetic data it is in the unit of measurement associated with the data. (For a detailed discussion of tolerance, see [Section 1.5.5](#).)

Be sure that the tolerance value used is appropriate to the data and your purpose. If the results of LRS functions seem imprecise or incorrect, you may need to specify a smaller tolerance value.

For clip operations (see [Section 7.5.3](#)) and offset operations (see [Section 7.5.7](#)), if the returned segment has any shape points within the tolerance value of the input geometric segment from what would otherwise be the start point or end point of the returned segment, the shape point is used as the start point or end point of the returned segment. This is done to ensure that the resulting geometry does not contain any redundant vertices, which would cause the geometry to be invalid. For example, assume that the tolerance associated with the geometric segment (non-geodetic data) in [Figure 7–19](#) is 0.5.

Figure 7–19 Segment for Clip Operation Affected by Tolerance

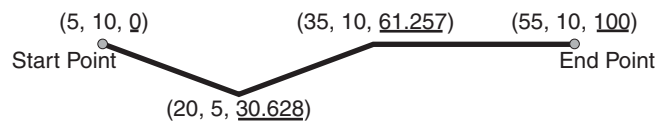

If you request a clip operation to return the segment between measure values 0 (the start point) and 61.5 in [Figure 7–19](#), and if the distance between the points associated with measure values 61.5 and 61.257 is less than the 0.5 tolerance value, the end point of the returned segment is (35, 10, 61.257).

7.7 Example of LRS Functions

This section presents a simplified example that uses LRS functions. It refers to concepts that are explained in this chapter and uses functions documented in [Chapter 25](#).

This example uses the road that is illustrated in [Figure 7–20](#).

Figure 7–20 Simplified LRS Example: Highway

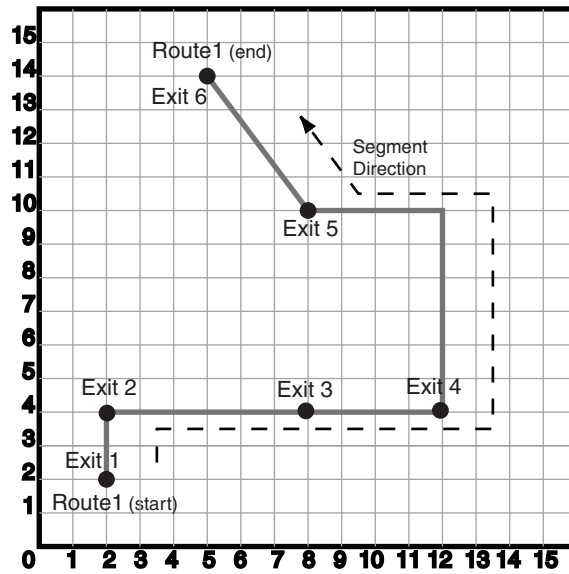

In [Figure 7–20](#), the highway (Route 1) starts at point 2,2 and ends at point 5,14, follows the path shown, and has six entrance-exit points (Exit 1 through Exit 6). For simplicity, each unit on the graph represents one unit of measure, and thus the measure from start to end is 27 (the segment from Exit 5 to Exit 6 being the hypotenuse of a 3-4-5 right triangle).

Each row in [Table 7–1](#) lists an actual highway-related feature and the LRS feature that corresponds to it or that can be used to represent it.

Table 7–1 Highway Features and LRS Counterparts

Highway Feature	LRS Feature
Named route, road, or street	LRS segment, or linear feature (logical set of segments)
Mile or kilometer marker	Measure
Accident reporting and location tracking	SDO_LRS.LOCATE_PT function
Construction zone (portion of a road)	SDO_LRS.CLIP_GEOM_SEGMENT function
Road extension (adding at the beginning or end) or combination (designating or renaming two roads that meet as one road)	SDO_LRS.CONCATENATE_GEOM_SEGMENTS function
Road reconstruction or splitting (resulting in two named roads from one named road)	SDO_LRS.SPLIT_GEOM_SEGMENT procedure
Finding the closest point on the road to a point off the road (such as a building)	SDO_LRS.PROJECT_PT function
Guard rail or fence alongside a road	SDO_LRS.OFFSET_GEOM_SEGMENT function

[Example 7–2](#) does the following:

- Creates a table to hold the segment depicted in [Figure 7–20](#)
- Inserts the definition of the highway depicted in [Figure 7–20](#) into the table

- Inserts the necessary metadata into the USER_SDO_GEOM_METADATA view
- Uses PL/SQL and SQL statements to define the segment and perform operations on it

Example 7-3 includes the output of the SELECT statements in Example 7-2.

Example 7-2 Simplified Example: Highway

```
-- Create a table for routes (highways).
CREATE TABLE lrs_routes (
  route_id NUMBER PRIMARY KEY,
  route_name VARCHAR2(32),
  route_geometry SDO_GEOMETRY);

-- Populate table with just one route for this example.
INSERT INTO lrs_routes VALUES(
  1,
  'Route1',
  SDO_GEOMETRY(
    3302, -- line string, 3 dimensions: X,Y,M
    NULL,
    NULL,
    SDO_ELEM_INFO_ARRAY(1,2,1), -- one line string, straight segments
    SDO_ORDINATE_ARRAY(
      2,2,0, -- Start point - Exit1; 0 is measure from start.
      2,4,2, -- Exit2; 2 is measure from start.
      8,4,8, -- Exit3; 8 is measure from start.
      12,4,12, -- Exit4; 12 is measure from start.
      12,10,NULL, -- Not an exit; measure automatically calculated and filled.
      8,10,22, -- Exit5; 22 is measure from start.
      5,14,27) -- End point (Exit6); 27 is measure from start.
    )
  );

-- Update the Spatial metadata.
INSERT INTO user_sdo_geom_metadata
  (TABLE_NAME,
   COLUMN_NAME,
   DIMINFO,
   SRID)
VALUES (
  'lrs_routes',
  'route_geometry',
  SDO_DIM_ARRAY( -- 20X20 grid
    SDO_DIM_ELEMENT('X', 0, 20, 0.005),
    SDO_DIM_ELEMENT('Y', 0, 20, 0.005),
    SDO_DIM_ELEMENT('M', 0, 20, 0.005) -- Measure dimension
  ),
  NULL -- SRID
);

-- Create the spatial index.
CREATE INDEX lrs_routes_idx ON lrs_routes(route_geometry)
  INDEXTYPE IS MDSYS.SPATIAL_INDEX;

-- Test the LRS procedures.
DECLARE
geom_segment SDO_GEOMETRY;
line_string SDO_GEOMETRY;
dim_array SDO_DIM_ARRAY;
```

```

result_geom_1 SDO_GEOMETRY;
result_geom_2 SDO_GEOMETRY;
result_geom_3 SDO_GEOMETRY;

BEGIN

SELECT a.route_geometry into geom_segment FROM lrs_routes a
  WHERE a.route_name = 'Route1';
SELECT m.diminfo into dim_array from
  user_sdo_geom_metadata m
  WHERE m.table_name = 'LRS_ROUTES' AND m.column_name = 'ROUTE_GEOMETRY';

-- Define the LRS segment for Route1. This will populate any null measures.
-- No need to specify start and end measures, because they are already defined
-- in the geometry.
SDO_LRS.DEFINE_GEOM_SEGMENT (geom_segment, dim_array);

SELECT a.route_geometry INTO line_string FROM lrs_routes a
  WHERE a.route_name = 'Route1';

-- Split Route1 into two segments.
SDO_LRS.SPLIT_GEOM_SEGMENT(line_string,dim_array,5,result_geom_1,result_geom_2);

-- Concatenate the segments that were just split.
result_geom_3 := SDO_LRS.CONCATENATE_GEOM_SEGMENTS(result_geom_1, dim_array,
result_geom_2, dim_array);

-- Update and insert geometries into table, to display later.
UPDATE lrs_routes a SET a.route_geometry = geom_segment
  WHERE a.route_id = 1;

INSERT INTO lrs_routes VALUES(
  11,
  'result_geom_1',
  result_geom_1
);
INSERT INTO lrs_routes VALUES(
  12,
  'result_geom_2',
  result_geom_2
);
INSERT INTO lrs_routes VALUES(
  13,
  'result_geom_3',
  result_geom_3
);

END;
/

-- First, display the data in the LRS table.
SELECT route_id, route_name, route_geometry FROM lrs_routes;

-- Are result_geom_1 and result_geom2 connected?
SELECT  SDO_LRS.CONNECTED_GEOM_SEGMENTS(a.route_geometry,
      b.route_geometry, 0.005)
  FROM lrs_routes a, lrs_routes b
  WHERE a.route_id = 11 AND b.route_id = 12;

-- Is the Route1 segment valid?

```



```

SELECT SDO_LRS.VALID_GEOM_SEGMENT(route_geometry)
  FROM lrs_routes WHERE route_id = 1;

-- Is 50 a valid measure on Route1? (Should return FALSE; highest Route1 measure
is 27.)
SELECT SDO_LRS.VALID_MEASURE(route_geometry, 50)
  FROM lrs_routes WHERE route_id = 1;

-- Is the Route1 segment defined?
SELECT SDO_LRS.IS_GEOM_SEGMENT_DEFINED(route_geometry)
  FROM lrs_routes WHERE route_id = 1;

-- How long is Route1?
SELECT SDO_LRS.GEOM_SEGMENT_LENGTH(route_geometry)
  FROM lrs_routes WHERE route_id = 1;

-- What is the start measure of Route1?
SELECT SDO_LRS.GEOM_SEGMENT_START_MEASURE(route_geometry)
  FROM lrs_routes WHERE route_id = 1;

-- What is the end measure of Route1?
SELECT SDO_LRS.GEOM_SEGMENT_END_MEASURE(route_geometry)
  FROM lrs_routes WHERE route_id = 1;

-- What is the start point of Route1?
SELECT SDO_LRS.GEOM_SEGMENT_START_PT(route_geometry)
  FROM lrs_routes WHERE route_id = 1;

-- What is the end point of Route1?
SELECT SDO_LRS.GEOM_SEGMENT_END_PT(route_geometry)
  FROM lrs_routes WHERE route_id = 1;

-- Translate (shift measure values) (+10).
-- First, display the original segment; then, translate.
SELECT a.route_geometry FROM lrs_routes a WHERE a.route_id = 1;
SELECT SDO_LRS.TRANSLATE_MEASURE(a.route_geometry, m.diminfo, 10)
  FROM lrs_routes a, user_sdo_geom_metadata m
  WHERE m.table_name = 'LRS_ROUTES' AND m.column_name = 'ROUTE_GEOMETRY'
  AND a.route_id = 1;

-- Redefine geometric segment to "convert" miles to kilometers
DECLARE
geom_segment SDO_GEOMETRY;
dim_array SDO_DIM_ARRAY;

BEGIN

SELECT a.route_geometry into geom_segment FROM lrs_routes a
  WHERE a.route_name = 'Route1';
SELECT m.diminfo into dim_array from
  user_sdo_geom_metadata m
  WHERE m.table_name = 'LRS_ROUTES' AND m.column_name = 'ROUTE_GEOMETRY';

-- "Convert" mile measures to kilometers (27 * 1.609 = 43.443).
SDO_LRS.REDEFINE_GEOM_SEGMENT (geom_segment,
  dim_array,
  0, -- Zero starting measure: LRS segment starts at start of route.
  43.443); -- End of LRS segment. 27 miles = 43.443 kilometers.

-- Update and insert geometries into table, to display later.

```

```

UPDATE lrs_routes a SET a.route_geometry = geom_segment
  WHERE a.route_id = 1;

END;
/
-- Display the redefined segment, with all measures "converted."
SELECT a.route_geometry FROM lrs_routes a WHERE a.route_id = 1;

-- Clip a piece of Route1.
SELECT SDO_LRS.CLIP_GEOM_SEGMENT(route_geometry, 5, 10)
  FROM lrs_routes WHERE route_id = 1;

-- Point (9,3,NULL) is off the road; should return (9,4,9).
SELECT SDO_LRS.PROJECT_PT(route_geometry,
  SDO_GEOMETRY(3301, NULL, NULL,
    SDO_ELEM_INFO_ARRAY(1, 1, 1),
    SDO_ORDINATE_ARRAY(9, 3, NULL)) )
  FROM lrs_routes WHERE route_id = 1;

-- Return the measure of the projected point.
SELECT SDO_LRS.GET_MEASURE(
  SDO_LRS.PROJECT_PT(a.route_geometry, m.diminfo,
    SDO_GEOMETRY(3301, NULL, NULL,
      SDO_ELEM_INFO_ARRAY(1, 1, 1),
      SDO_ORDINATE_ARRAY(9, 3, NULL)) ),
  m.diminfo )
  FROM lrs_routes a, user_sdo_geom_metadata m
  WHERE m.table_name = 'LRS_ROUTES' AND m.column_name = 'ROUTE_GEOMETRY'
    AND a.route_id = 1;

-- Is point (9,3,NULL) a valid LRS point? (Should return TRUE.)
SELECT SDO_LRS.VALID_LRS_PT(
  SDO_GEOMETRY(3301, NULL, NULL,
    SDO_ELEM_INFO_ARRAY(1, 1, 1),
    SDO_ORDINATE_ARRAY(9, 3, NULL)),
  m.diminfo)
  FROM lrs_routes a, user_sdo_geom_metadata m
  WHERE m.table_name = 'LRS_ROUTES' AND m.column_name = 'ROUTE_GEOMETRY'
    AND a.route_id = 1;

-- Locate the point on Route1 at measure 9, offset 0.
SELECT SDO_LRS.LOCATE_PT(route_geometry, 9, 0)
  FROM lrs_routes WHERE route_id = 1;

```

[Example 7-3](#) shows the output of the SELECT statements in [Example 7-2](#).

Example 7-3 Simplified Example: Output of SELECT Statements

```

SQL> -- First, display the data in the LRS table.
SQL> SELECT route_id, route_name, route_geometry FROM lrs_routes;

  ROUTE_ID ROUTE_NAME
-----
ROUTE_GEOMETRY(SDO_GTYPE, SDO_SRID, SDO_POINT(X, Y, Z), SDO_ELEM_INFO, SDO_ORDIN
-----
      1 Route1
SDO_GEOMETRY(3302, NULL, NULL, SDO_ELEM_INFO_ARRAY(1, 2, 1), SDO_ORDINATE_ARRAY(
2, 2, 0, 2, 4, 2, 8, 4, 8, 12, 4, 12, 12, 10, 18, 8, 10, 22, 5, 14, 27))

      11 result_geom_1

```

```
SDO_GEOMETRY(3302, NULL, NULL, SDO_ELEM_INFO_ARRAY(1, 2, 1), SDO_ORDINATE_ARRAY(
2, 2, 0, 2, 4, 2, 5, 4, 5))
```

```
12 result_geom_2
```

```
ROUTE_ID ROUTE_NAME
```

```
-----
ROUTE_GEOMETRY(SDO_GTYPE, SDO_SRID, SDO_POINT(X, Y, Z), SDO_ELEM_INFO, SDO_ORDIN
-----
SDO_GEOMETRY(3302, NULL, NULL, SDO_ELEM_INFO_ARRAY(1, 2, 1), SDO_ORDINATE_ARRAY(
5, 4, 5, 8, 4, 8, 12, 4, 12, 12, 10, 18, 8, 10, 22, 5, 14, 27))
```

```
13 result_geom_3
```

```
SDO_GEOMETRY(3302, NULL, NULL, SDO_ELEM_INFO_ARRAY(1, 2, 1), SDO_ORDINATE_ARRAY(
2, 2, 0, 2, 4, 2, 5, 4, 5, 8, 4, 8, 12, 4, 12, 12, 10, 18, 8, 10, 22, 5, 14, 27)
)
```

```
SQL> -- Are result_geom_1 and result_geom2 connected?
```

```
SQL> SELECT SDO_LRS.CONNECTED_GEOM_SEGMENTS(a.route_geometry,
2 b.route_geometry, 0.005)
3 FROM lrs_routes a, lrs_routes b
4 WHERE a.route_id = 11 AND b.route_id = 12;
```

```
SDO_LRS.CONNECTED_GEOM_SEGMENTS(A.ROUTE_GEOMETRY,B.ROUTE_GEOMETRY,0.005)
```

```
-----
TRUE
```

```
SQL> -- Is the Route1 segment valid?
```

```
SQL> SELECT SDO_LRS.VALID_GEOM_SEGMENT(route_geometry)
2 FROM lrs_routes WHERE route_id = 1;
```

```
SDO_LRS.VALID_GEOM_SEGMENT(ROUTE_GEOMETRY)
```

```
-----
TRUE
```

```
SQL> -- Is 50 a valid measure on Route1? (Should return FALSE; highest Route1
measure is 27.)
```

```
SQL> SELECT SDO_LRS.VALID_MEASURE(route_geometry, 50)
2 FROM lrs_routes WHERE route_id = 1;
```

```
SDO_LRS.VALID_MEASURE(ROUTE_GEOMETRY,50)
```

```
-----
FALSE
```

```
SQL> -- Is the Route1 segment defined?
```

```
SQL> SELECT SDO_LRS.IS_GEOM_SEGMENT_DEFINED(route_geometry)
2 FROM lrs_routes WHERE route_id = 1;
```

```
SDO_LRS.IS_GEOM_SEGMENT_DEFINED(ROUTE_GEOMETRY)
```

```
-----
TRUE
```

```
SQL> -- How long is Route1?
```

```
SQL> SELECT SDO_LRS.GEOM_SEGMENT_LENGTH(route_geometry)
2 FROM lrs_routes WHERE route_id = 1;
```

```
SDO_LRS.GEOM_SEGMENT_LENGTH(ROUTE_GEOMETRY)
```

```
-----
27
```

```

SQL> -- What is the start measure of Route1?
SQL> SELECT  SDO_LRS.GEOM_SEGMENT_START_MEASURE(route_geometry)
      2     FROM lrs_routes WHERE route_id = 1;

SDO_LRS.GEOM_SEGMENT_START_MEASURE(ROUTE_GEOMETRY)
-----
0

SQL> -- What is the end measure of Route1?
SQL> SELECT  SDO_LRS.GEOM_SEGMENT_END_MEASURE(route_geometry)
      2     FROM lrs_routes WHERE route_id = 1;

SDO_LRS.GEOM_SEGMENT_END_MEASURE(ROUTE_GEOMETRY)
-----
27

SQL> -- What is the start point of Route1?
SQL> SELECT  SDO_LRS.GEOM_SEGMENT_START_PT(route_geometry)
      2     FROM lrs_routes WHERE route_id = 1;

SDO_LRS.GEOM_SEGMENT_START_PT(ROUTE_GEOMETRY) (SDO_GTYPE, SDO_SRID, SDO_POINT(X,
-----
SDO_GEOMETRY(3301, NULL, NULL, SDO_ELEM_INFO_ARRAY(1, 1, 1), SDO_ORDINATE_ARRAY(
2, 2, 0))

SQL> -- What is the end point of Route1?
SQL> SELECT  SDO_LRS.GEOM_SEGMENT_END_PT(route_geometry)
      2     FROM lrs_routes WHERE route_id = 1;

SDO_LRS.GEOM_SEGMENT_END_PT(ROUTE_GEOMETRY) (SDO_GTYPE, SDO_SRID, SDO_POINT(X, Y,
-----
SDO_GEOMETRY(3301, NULL, NULL, SDO_ELEM_INFO_ARRAY(1, 1, 1), SDO_ORDINATE_ARRAY(
5, 14, 27))

SQL> -- Translate (shift measure values) (+10).
SQL> -- First, display the original segment; then, translate.
SQL> SELECT a.route_geometry FROM lrs_routes a WHERE a.route_id = 1;

ROUTE_GEOMETRY(SDO_GTYPE, SDO_SRID, SDO_POINT(X, Y, Z), SDO_ELEM_INFO, SDO_ORDIN
-----
SDO_GEOMETRY(3302, NULL, NULL, SDO_ELEM_INFO_ARRAY(1, 2, 1), SDO_ORDINATE_ARRAY(
2, 2, 0, 2, 4, 2, 8, 4, 8, 12, 4, 12, 12, 10, 18, 8, 10, 22, 5, 14, 27))

SQL> SELECT SDO_LRS.TRANSLATE_MEASURE(a.route_geometry, m.diminfo, 10)
      2     FROM lrs_routes a, user_sdo_geom_metadata m
      3     WHERE m.table_name = 'LRS_ROUTES' AND m.column_name = 'ROUTE_GEOMETRY'
      4     AND a.route_id = 1;

SDO_LRS.TRANSLATE_MEASURE(A.ROUTE_GEOMETRY,M.DIMINFO,10) (SDO_GTYPE, SDO_SRID, SD
-----
SDO_GEOMETRY(3302, NULL, NULL, SDO_ELEM_INFO_ARRAY(1, 2, 1), SDO_ORDINATE_ARRAY(
2, 2, 10, 2, 4, 12, 8, 4, 18, 12, 4, 22, 12, 10, 28, 8, 10, 32, 5, 14, 37))

SQL> -- Redefine geometric segment to "convert" miles to kilometers
SQL> DECLARE
      2 geom_segment SDO_GEOMETRY;
      3 dim_array SDO_DIM_ARRAY;
      4
      5 BEGIN

```

```

6
7  SELECT a.route_geometry into geom_segment FROM lrs_routes a
8     WHERE a.route_name = 'Route1';
9  SELECT m.diminfo into dim_array from
10     user_sdo_geom_metadata m
11     WHERE m.table_name = 'LRS_ROUTES' AND m.column_name = 'ROUTE_GEOMETRY';
12
13  -- "Convert" mile measures to kilometers (27 * 1.609 = 43.443).
14  SDO_LRS.REDEFINE_GEOM_SEGMENT (geom_segment,
15     dim_array,
16     0, -- Zero starting measure: LRS segment starts at start of route.
17     43.443); -- End of LRS segment. 27 miles = 43.443 kilometers.
18
19  -- Update and insert geometries into table, to display later.
20  UPDATE lrs_routes a SET a.route_geometry = geom_segment
21  WHERE a.route_id = 1;
22
23  END;
24  /

```

PL/SQL procedure successfully completed.

```

SQL> -- Display the redefined segment, with all measures "converted."
SQL> SELECT a.route_geometry FROM lrs_routes a WHERE a.route_id = 1;

```

```

ROUTE_GEOMETRY(SDO_GTYPE, SDO_SRID, SDO_POINT(X, Y, Z), SDO_ELEM_INFO, SDO_ORDIN
-----
SDO_GEOMETRY(3302, NULL, NULL, SDO_ELEM_INFO_ARRAY(1, 2, 1), SDO_ORDINATE_ARRAY(
2, 2, 0, 2, 4, 3.218, 8, 4, 12.872, 12, 4, 19.308, 12, 10, 28.962, 8, 10, 35.398
, 5, 14, 43.443))

```

```

SQL> -- Clip a piece of Route1.
SQL> SELECT SDO_LRS.CLIP_GEOM_SEGMENT(route_geometry, 5, 10)
2     FROM lrs_routes WHERE route_id = 1;

```

```

SDO_LRS.CLIP_GEOM_SEGMENT(ROUTE_GEOMETRY,5,10)(SDO_GTYPE, SDO_SRID, SDO_POINT(X,
-----
SDO_GEOMETRY(3302, NULL, NULL, SDO_ELEM_INFO_ARRAY(1, 2, 1), SDO_ORDINATE_ARRAY(
5, 4, 5, 8, 4, 8, 10, 4, 10))

```

```

SQL> -- Point (9,3,NULL) is off the road; should return (9,4,9).

```

```

SQL> SELECT SDO_LRS.PROJECT_PT(route_geometry,
2     SDO_GEOMETRY(3301, NULL, NULL,
3     SDO_ELEM_INFO_ARRAY(1, 1, 1),
4     SDO_ORDINATE_ARRAY(9, 3, NULL)) )
5     FROM lrs_routes WHERE route_id = 1;

```

```

SDO_LRS.PROJECT_PT(ROUTE_GEOMETRY,SDO_GEOMETRY(3301,NULL,NULL,SDO_EL
-----
SDO_GEOMETRY(3301, NULL, NULL, SDO_ELEM_INFO_ARRAY(1, 1, 1), SDO_ORDINATE_ARRAY(
9, 4, 9))

```

```

SQL> -- Return the measure of the projected point.

```

```

SQL> SELECT SDO_LRS.GET_MEASURE(
2     SDO_LRS.PROJECT_PT(a.route_geometry, m.diminfo,
3     SDO_GEOMETRY(3301, NULL, NULL,
4     SDO_ELEM_INFO_ARRAY(1, 1, 1),
5     SDO_ORDINATE_ARRAY(9, 3, NULL)) ),
6     m.diminfo )
7     FROM lrs_routes a, user_sdo_geom_metadata m

```

```

8 WHERE m.table_name = 'LRS_ROUTES' AND m.column_name = 'ROUTE_GEOMETRY'
9 AND a.route_id = 1;

```

```

SDO_LRS.GET_MEASURE(SDO_LRS.PROJECT_PT(A.ROUTE_GEOMETRY,M.DIMINFO,SDO_GEOM
-----

```

9

```

SQL> -- Is point (9,3,NULL) a valid LRS point? (Should return TRUE.)

```

```

SQL> SELECT SDO_LRS.VALID_LRS_PT(
2 SDO_GEOMETRY(3301, NULL, NULL,
3 SDO_ELEM_INFO_ARRAY(1, 1, 1),
4 SDO_ORDINATE_ARRAY(9, 3, NULL)),
5 m.diminfo)
6 FROM lrs_routes a, user_sdo_geom_metadata m
7 WHERE m.table_name = 'LRS_ROUTES' AND m.column_name = 'ROUTE_GEOMETRY'
8 AND a.route_id = 1;

```

```

SDO_LRS.VALID_LRS_PT(SDO_GEOMETRY(3301,NULL,NULL,SDO_ELEM_INFO_ARRAY
-----

```

TRUE

```

SQL> -- Locate the point on Route1 at measure 9, offset 0.

```

```

SQL> SELECT SDO_LRS.LOCATE_PT(route_geometry, 9, 0)
2 FROM lrs_routes WHERE route_id = 1;

```

```

SDO_LRS.LOCATE_PT(ROUTE_GEOMETRY,9,0)(SDO_GTYPE, SDO_SRID, SDO_POINT(X, Y, Z), S
-----

```

```

SDO_GEOMETRY(3301, NULL, NULL, SDO_ELEM_INFO_ARRAY(1, 1, 1), SDO_ORDINATE_ARRAY(
9, 4, 9))

```

Spatial Analysis and Mining

This chapter describes the Oracle Spatial support for spatial analysis and mining in Oracle Data Mining (ODM) applications.

Note: To use the features described in this chapter, you must understand the main concepts and techniques explained in the Oracle Data Mining documentation.

For reference information about spatial analysis and mining functions and procedures in the SDO_SAM package, see [Chapter 29](#).

Note: SDO_SAM subprograms are supported for two-dimensional geometries only. They are not supported for three-dimensional geometries.

This chapter contains the following major sections:

- [Section 8.1, "Spatial Information and Data Mining Applications"](#)
- [Section 8.2, "Spatial Binning for Detection of Regional Patterns"](#)
- [Section 8.3, "Materializing Spatial Correlation"](#)
- [Section 8.4, "Colocation Mining"](#)
- [Section 8.5, "Spatial Clustering"](#)
- [Section 8.6, "Location Prospecting"](#)

8.1 Spatial Information and Data Mining Applications

ODM allows automatic discovery of knowledge from a database. Its techniques include discovering hidden associations between different data attributes, classification of data based on some samples, and clustering to identify intrinsic patterns. Spatial data can be materialized for inclusion in data mining applications. Thus, ODM might enable you to discover that sales prospects with addresses located in specific areas (neighborhoods, cities, or regions) are more likely to watch a particular television program or to respond favorably to a particular advertising solicitation. (The addresses are geocoded into longitude/latitude points and stored in an Oracle Spatial geometry object.)

In many applications, data at a specific location is influenced by data in the neighborhood. For example, the value of a house is largely determined by the value of

other houses in the neighborhood. This phenomenon is called *spatial correlation* (or, neighborhood influence), and is discussed further in [Section 8.3](#). The spatial analysis and mining features in Oracle Spatial let you exploit spatial correlation by using the location attributes of data items in several ways: for binning (discretizing) data into regions (such as categorizing data into northern, southern, eastern, and western regions), for materializing the influence of neighborhood (such as number of customers within a two-mile radius of each store), and for identifying colocated data items (such as video rental stores and pizza restaurants).

To perform spatial data mining, you materialize spatial predicates and relationships for a set of spatial data using thematic layers. Each layer contains data about a specific kind of spatial data (that is, having a specific "theme"), for example, parks and recreation areas, or demographic income data. The spatial materialization could be performed as a preprocessing step before the application of data mining techniques, or it could be performed as an intermediate step in spatial mining, as shown in [Figure 8-1](#).

Figure 8-1 Spatial Mining and Oracle Data Mining

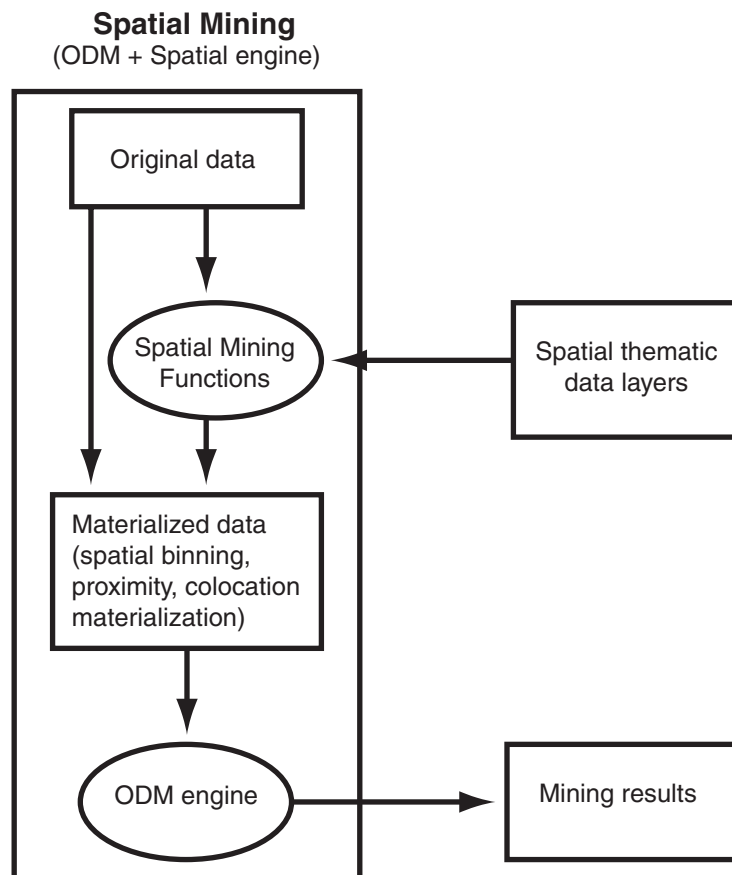

Notes on [Figure 8-1](#):

- The original data, which included spatial and nonspatial data, is processed to produce materialized data.
- Spatial data in the original data is processed by spatial mining functions to produce materialized data. The processing includes such operations as spatial binning, proximity, and colocation materialization.

- The ODM engine processes materialized data (spatial and nonspatial) to generate mining results.

The following are examples of the kinds of data mining applications that could benefit from including spatial information in their processing:

- Business prospecting: Determine if colocation of a business with another franchise (such as colocation of a Pizza Hut restaurant with a Blockbuster video store) might improve its sales.
- Store prospecting: Find a good store location that is within 50 miles of a major city and inside a state with no sales tax. (Although 50 miles is probably too far to drive to avoid a sales tax, many customers may live near the edge of the 50-mile radius and thus be near the state with no sales tax.)
- Hospital prospecting: Identify the best locations for opening new hospitals based on the population of patients who live in each neighborhood.
- Spatial region-based classification or personalization: Determine if southeastern United States customers in a certain age or income category are more likely to prefer "soft" or "hard" rock music.
- Automobile insurance: Given a customer's home or work location, determine if it is in an area with high or low rates of accident claims or auto thefts.
- Property analysis: Use colocation rules to find hidden associations between proximity to a highway and either the price of a house or the sales volume of a store.
- Property assessment: In assessing the value of a house, examine the values of similar houses in a neighborhood, and derive an estimate based on variations and spatial correlation.

8.2 Spatial Binning for Detection of Regional Patterns

Spatial binning (spatial discretization) discretizes the location values into a small number of groups associated with geographical areas. The assignment of a location to a group can be done by any of the following methods:

- Reverse geocoding the longitude/latitude coordinates to obtain an address that specifies (for United States locations) the ZIP code, city, state, and country
- Checking a spatial bin table to determine which bin this specific location belongs in

You can then apply ODM techniques to the discretized locations to identify interesting regional patterns or association rules. For example, you might discover that customers in area A prefer regular soda, while customers in area B prefer diet soda.

The following functions and procedures, documented in [Chapter 29](#), perform operations related to spatial binning:

- [SDO_SAM.BIN_GEOMETRY](#)
- [SDO_SAM.BIN_LAYER](#)

8.3 Materializing Spatial Correlation

Spatial correlation (or, *neighborhood influence*) refers to the phenomenon of the location of a specific object in an area affecting some nonspatial attribute of the object. For example, the value (nonspatial attribute) of a house at a given address (geocoded to

give a spatial attribute) is largely determined by the value of other houses in the neighborhood.

To use spatial correlation in a data mining application, you materialize the spatial correlation by adding attributes (columns) in a data mining table. You use associated thematic tables to add the appropriate attributes. You then perform mining tasks on the data mining table using ODM functions.

The following functions and procedures, documented in [Chapter 29](#), perform operations related to materializing spatial correlation:

- [SDO_SAM.SIMPLIFY_GEOMETRY](#)
- [SDO_SAM.SIMPLIFY_LAYER](#)
- [SDO_SAM.AGGREGATES_FOR_GEOMETRY](#)
- [SDO_SAM.AGGREGATES_FOR_LAYER](#)

8.4 Colocation Mining

Colocation is the presence of two or more spatial objects at the same location or at significantly close distances from each other. Colocation patterns can indicate interesting associations among spatial data objects with respect to their nonspatial attributes. For example, a data mining application could discover that sales at franchises of a specific pizza restaurant chain were higher at restaurants collocated with video stores than at restaurants not collocated with video stores.

Two types of colocation mining are supported:

- Colocation of items in a data mining table. Given a data layer, this approach identifies the colocation of multiple features. For example, predator and prey species could be collocated in animal habitats, and high-sales pizza restaurants could be collocated with high-sales video stores. You can use a reference-feature approach (using one feature as a reference and the other features as thematic attributes, and materializing all neighbors for the reference feature) or a buffer-based approach (materializing all items that are within all windows of a specified size).
- Colocation with thematic layers. Given several data layers, this approach identifies colocation across the layers. For example, given a lakes layer and a vegetation layer, lakes could be collocated with areas of high vegetation. You materialize the data, add categorical and numerical spatial relationships to the data mining table, and apply the ODM Association-Rule mechanisms.

The following functions and procedures, documented in [Chapter 29](#), perform operations related to colocation mining:

- [SDO_SAM.COLOCATED_REFERENCE_FEATURES](#)
- [SDO_SAM.BIN_GEOMETRY](#)

8.5 Spatial Clustering

Spatial clustering returns cluster geometries for a layer of data. An example of spatial clustering is the clustering of crime location data.

The [SDO_SAM.SPATIAL_CLUSTERS](#) function, documented in [Chapter 29](#), performs spatial clustering. This function requires a spatial R-tree index on the geometry column of the layer, and it returns a set of `SDO_REGION` objects where the geometry

column specifies the boundary of each cluster and the `geometry_key` value is set to null.

You can use the [SDO_SAM.BIN_GEOMETRY](#) function, with the returned spatial clusters in the bin table, to identify the cluster to which a geometry belongs.

8.6 Location Prospecting

Location prospecting can be performed by using thematic layers to compute aggregates for a layer, and choosing the locations that have the maximum values for computed aggregates.

The following functions, documented in [Chapter 29](#), perform operations related to location prospecting:

- [SDO_SAM.AGGREGATES_FOR_GEOMETRY](#)
- [SDO_SAM.AGGREGATES_FOR_LAYER](#)
- [SDO_SAM.TILED_AGGREGATES](#)

Extending Spatial Indexing Capabilities

This chapter shows how to create and use spatial indexes on objects other than a geometry column. In other chapters, the focus is on indexing and querying spatial data that is stored in a single column of type `SDO_GEOMETRY`. This chapter shows how to:

- Embed an `SDO_GEOMETRY` object in a user-defined object type, and index the geometry attribute of that type (see [Section 9.1](#))
- Create and use a function-based index where the function returns an `SDO_GEOMETRY` object (see [Section 9.2](#))

The techniques in this chapter are intended for experienced and knowledgeable application developers. You should be familiar with the Spatial concepts and techniques described in other chapters. You should also be familiar with, or able to learn about, relevant Oracle database features, such as user-defined data types and function-based indexing.

9.1 SDO_GEOMETRY Objects in User-Defined Type Definitions

The `SDO_GEOMETRY` type can be embedded in a user-defined data type definition. The procedure is very similar to that for using the `SDO_GEOMETRY` type for a spatial data column:

1. Create the user-defined data type.
2. Create a table with a column based on that data type.
3. Insert data into the table.
4. Update the `USER_SDO_GEOM_METADATA` view.
5. Create the spatial index on the geometry attribute.
6. Perform queries on the data.

For example, assume that you want to follow the cola markets scenario in the simplified example in [Section 2.1](#), but want to incorporate the market name attribute and the geometry attribute in a single type. First, create the user-defined data type, as in the following example that creates an object type named `MARKET_TYPE`:

```
CREATE OR REPLACE TYPE market_type AS OBJECT
  (name VARCHAR2(32), shape SDO_GEOMETRY);
/
```

Create a table that includes a column based on the user-defined type. The following example creates a table named `COLA_MARKETS_2` that will contain the same information as the `COLA_MARKETS` table used in the example in [Section 2.1](#).

```
CREATE TABLE cola_markets_2 (
  mkt_id NUMBER PRIMARY KEY,
  market MARKET_TYPE);
```

Insert data into the table, using the object type name as a constructor. For example:

```
INSERT INTO cola_markets_2 VALUES(
  1,
  MARKET_TYPE('cola_a',
  SDO_GEOMETRY(
    2003, -- two-dimensional polygon
    NULL,
    NULL,
    SDO_ELEM_INFO_ARRAY(1,1003,3), -- one rectangle (1003 = exterior)
    SDO_ORDINATE_ARRAY(1,1, 5,7) -- only 2 points needed to
      -- define rectangle (lower left and upper right)
  )
  )
);
```

Update the USER_SDO_GEOM_METADATA view, using dot-notation to specify the column name and spatial attribute. The following example specifies MARKET.SHAPE as the COLUMN_NAME (explained in [Section 2.8.2](#)) in the metadata view.

```
INSERT INTO user_sdo_geom_metadata
  (TABLE_NAME,
  COLUMN_NAME,
  DIMINFO,
  SRID)
VALUES (
  'cola_markets_2',
  'market.shape',
  SDO_DIM_ARRAY( -- 20X20 grid
    SDO_DIM_ELEMENT('X', 0, 20, 0.005),
    SDO_DIM_ELEMENT('Y', 0, 20, 0.005)
  ),
  NULL -- SRID
);
```

Create the spatial index, specifying the column name and spatial attribute using dot-notation. For example.

```
CREATE INDEX cola_spatial_idx_2
ON cola_markets_2(market.shape)
INDEXTYPE IS MDSYS.SPATIAL_INDEX;
```

Perform queries on the data, using dot-notation to refer to attributes of the user-defined type. The following simple query returns information associated with the cola market named cola_a.

```
SELECT c.mkt_id, c.market.name, c.market.shape
  FROM cola_markets_2 c
 WHERE c.market.name = 'cola_a';
```

The following query returns information associated with all geometries that have any spatial interaction with a specified query window, namely, the rectangle with lower-left coordinates (4,6) and upper-right coordinates (8,8).

```
SELECT c.mkt_id, c.market.name, c.market.shape
  FROM cola_markets_2 c
 WHERE SDO_RELATE(c.market.shape,
```

```

SDO_GEOMETRY(2003, NULL, NULL,
  SDO_ELEM_INFO_ARRAY(1,1003,3),
  SDO_ORDINATE_ARRAY(4,6, 8,8)),
'mask=anyinteract' = 'TRUE';

```

9.2 SDO_GEOMETRY Objects in Function-Based Indexes

A function-based spatial index facilitates queries that use locational information (of type SDO_GEOMETRY) returned by a function or expression. In this case, the spatial index is created based on the precomputed values returned by the function or expression.

If you are not already familiar with function-based indexes, see the following for detailed explanations of their benefits, options, and requirements, as well as usage examples:

- *Oracle Database Advanced Application Developer's Guide*
- *Oracle Database Administrator's Guide*

The procedure for using an SDO_GEOMETRY object in a function-based index is as follows:

1. Create the function that returns an SDO_GEOMETRY object.

The function must be declared as DETERMINISTIC.

2. If the spatial data table does not already exist, create it, and insert data into the table.
3. Update the USER_SDO_GEOM_METADATA view.
4. Create the spatial index.

For a function-based spatial index, the number of parameters must not exceed 32.

5. Perform queries on the data.

The rest of this section describes two examples of using function-based indexes. In both examples, a function is created that returns an SDO_GEOMETRY object, and a spatial index is created on that function. In the first example, the input parameters to the function are a standard Oracle data type (NUMBER). In the second example, the input to the function is a user-defined object type.

9.2.1 Example: Function with Standard Types

In the following example, the input parameters to the function used for the function-based index are standard numeric values (longitude and latitude).

Assume that you want to create a function that returns the longitude and latitude of a point and to use that function in a spatial index. First, create the function, as in the following example that creates a function named GET_LONG_LAT_PT:

```

-- Create a function to return a point geometry (SDO_GTYPE = 2001) with
-- input of 2 numbers: longitude and latitude (SDO_SRID = 8307, for
-- "Longitude / Latitude (WGS 84)", probably the most widely used
-- coordinate system, and the one used for GPS devices.
-- Specify DETERMINISTIC for the function.

```

```

create or replace function get_long_lat_pt(longitude in number,
                                          latitude in number)
return SDO_GEOMETRY deterministic is
begin

```

```

        return sdo_geometry(2001, 8307,
            sdo_point_type(longitude, latitude, NULL),NULL, NULL);
end;
/

```

If the spatial data table does not already exist, create the table and add data to it, as in the following example that creates a table named LONG_LAT_TABLE:

```

create table LONG_LAT_TABLE
(lon number, lat number, name varchar2(32));

insert into LONG_LAT_TABLE values (10,10, 'Place1');
insert into LONG_LAT_TABLE values (20,20, 'Place2');
insert into LONG_LAT_TABLE values (30,30, 'Place3');

```

Update the USER_SDO_GEOM_METADATA view, using dot-notation to specify the schema name and function name. The following example specifies SCOTT.GET_LONG_LAT_PT(LON,LAT) as the COLUMN_NAME (explained in [Section 2.8.2](#)) in the metadata view.

```

-- Set up the metadata entry for this table.
-- The column name sets up the function on top
-- of the two columns used in this function,
-- along with the owner of the function.
insert into user_sdo_geom_metadata values('LONG_LAT_TABLE',
'scott.get_long_lat_pt(lon,lat)',
sdo_dim_array(
sdo_dim_element('Longitude', -180, 180, 0.005),
sdo_dim_element('Latitude', -90, 90, 0.005)), 8307);

```

Create the spatial index, specifying the function name with parameters. For example:

```

create index LONG_LAT_TABLE_IDX on
LONG_LAT_TABLE(get_long_lat_pt(lon,lat))
indextype is mdsys.spatial_index;

```

Perform queries on the data. The following example specifies the user-defined function in a call to the [SDO_FILTER](#) operator.

```

select name from LONG_LAT_TABLE a
where sdo_filter(
get_long_lat_pt(a.lon,a.lat),
sdo_geometry(2001, 8307, sdo_point_type(10,10,NULL), NULL, NULL)
)= 'TRUE';

```

```

NAME
-----
Place1

```

9.2.2 Example: Function with a User-Defined Object Type

In the following example, the input parameter to the function used for the function-based index is an object of a user-defined type that includes the longitude and latitude.

Assume that you want to create a function that returns the longitude and latitude of a point and to create a spatial index on that function. First, create the user-defined data type, as in the following example that creates an object type named LONG_LAT and its member function GetGeometry:

```

create type long_lat as object (

```



```

        longitude number,
        latitude number,
member function GetGeometry(SELF in long_lat)
RETURN SDO_GEOMETRY DETERMINISTIC)
/

create or replace type body long_lat as
member function GetGeometry(self in long_lat)
return SDO_GEOMETRY is
begin
    return sdo_geometry(2001, 8307,
        sdo_point_type(longitude, latitude, NULL), NULL, NULL);
end;
end;
/

```

If the spatial data table does not already exist, create the table and add data to it, as in the following example that creates a table named TEST_LONG_LAT:

```

create table test_long_lat
(location long_lat, name varchar2(32));

insert into test_long_lat values (long_lat(10,10), 'Place1');
insert into test_long_lat values (long_lat(20,20), 'Place2');
insert into test_long_lat values (long_lat(30,30), 'Place3');

```

Update the USER_SDO_GEOM_METADATA view, using dot-notation to specify the schema name, table name, and function name and parameter value. The following example specifies SCOTT.LONG_LAT.GetGeometry(LOCATION) as the COLUMN_NAME (explained in [Section 2.8.2](#)) in the metadata view.

```

insert into user_sdo_geom_metadata values('test_long_lat',
'scott.long_lat.GetGeometry(location)',
sdo_dim_array(
sdo_dim_element('Longitude', -180, 180, 0.005),
sdo_dim_element('Latitude', -90, 90, 0.005)), 8307);

```

Create the spatial index, specifying the column name and function name using dot-notation. For example:

```

create index test_long_lat_idx on test_long_lat(location.GetGeometry())
indextype is mdsys.spatial_index;

```

Perform queries on the data. The following query performs a primary filter operation, asking for the names of geometries that are likely to interact spatially with point (10,10).

```

SELECT a.name FROM test_long_lat a
WHERE SDO_FILTER(a.location.GetGeometry(),
SDO_GEOMETRY(2001, 8307,
SDO_POINT_TYPE(10,10,NULL), NULL, NULL)
) = 'TRUE';

```

Part II

Spatial Web Services

This document has the following parts:

- [Part I](#) provides conceptual and usage information about Oracle Spatial.
- Part II provides conceptual and usage information about Oracle Spatial Web services.
- [Part III](#) provides reference information about Oracle Spatial operators, functions, and procedures.
- [Part IV](#) provides supplementary information (appendixes and a glossary).

Part II contains the following chapters:

- [Chapter 10, "Introduction to Spatial Web Services"](#)
- [Chapter 11, "Geocoding Address Data"](#)
- [Chapter 12, "Business Directory \(Yellow Pages\) Support"](#)
- [Chapter 13, "Routing Engine"](#)
- [Chapter 14, "OpenLS Support"](#)
- [Chapter 15, "Web Feature Service \(WFS\) Support"](#)
- [Chapter 16, "Catalog Services for the Web \(CSW\) Support"](#)
- [Chapter 17, "Security Considerations for Spatial Web Services"](#)

Introduction to Spatial Web Services

This chapter introduces the Oracle Spatial support for spatial Web services. A Web service enables developers of Oracle Spatial applications to provide feature data and metadata to their application users over the Web.

This chapter contains the following major sections:

Note: If you are using Spatial Web Feature Service (WFS) or Catalog Services for the Web (CSW) support, and if you have data from a previous release that was indexed using one or more SYS.XMLTABLEINDEX indexes, you must drop the associated indexes **before** the upgrade and re-create the indexes after the upgrade.

For more information, see [Section A.2](#).

- [Section 10.1, "Types of Spatial Web Services"](#)
- [Section 10.2, "Types of Users of Spatial Web Services"](#)
- [Section 10.3, "Setting Up the Client for Spatial Web Services"](#)
- [Section 10.4, "Demo Files for Sample Java Client"](#)

10.1 Types of Spatial Web Services

Oracle Spatial provides the following types of Web services:

- Geocoding, which enables users to associate spatial locations (longitude and latitude coordinates) with postal addresses. Geocoding support is explained in [Chapter 11](#).
- Yellow Pages, which enables users to find businesses by name or category based on their relationship to a location. Yellow Pages support is explained in [Chapter 12](#).
- Routing, which provides driving information and instructions for individual or multiple routes. Routing support is explained in [Chapter 13](#).
- OpenLS, which provides location-based services based on the Open Location Services Initiative (OpenLS) specification for geocoding, mapping, routing, and yellow pages. OpenLS support is explained in [Chapter 14](#).
- Web Feature Services (WFS), which enables users to find features (roads, rivers, and so on) based on their relationship to a location or a nonspatial attribute. WFS support is explained in [Chapter 15](#).

- Catalog Services for the Web (CSW), which describes the Oracle Spatial implementation of the Open GIS Consortium specification for catalog services. According to this specification: "Catalogue services support the ability to publish and search collections of descriptive information (metadata) for data, services, and related information objects." CSW support is explained in [Chapter 16](#).

Security considerations for Web services are explained in [Chapter 17](#).

10.2 Types of Users of Spatial Web Services

In the general business sense of the word "user," implementing any spatial Web services application involves the following kinds of people:

- Administrators set up the Web services infrastructure. Administrators might create database users, grant privileges and access rights to new and existing database users, and do other operations that affect multiple database users. For Web feature services, administrators register feature tables, publish feature types, and unlock certain accounts.

For example, an administrator might set up the infrastructure to enable access to spatial features, such as roads and rivers.

- Application developers create and manage the spatial data and metadata. They create spatial data tables, create spatial indexes, insert rows into the `USER_SDO_GEOM_METADATA` view, and use Spatial functions and procedures to implement the application logic.

For example, an application developer might create tables of roads and rivers, and implement application logic that enables end users to find roads and rivers based on spatial query criteria.

- End users access the services through their Web browsers.

For example, an end user might ask for all roads that are within one mile of a specific river or that intersect (cross) that river.

From the perspective of an administrator, application developers and end users are all "users" because database users must be created to accommodate their needs. Application developers will connect to the database as users with sufficient privileges to create and manage spatial tables and to use Oracle Spatial functions and procedures. End users will access the database through a database user with limited access privileges, typically read-only access to data or limited write access.

The chapters about Spatial Web services are written for administrators and application developers, not for end users.

10.3 Setting Up the Client for Spatial Web Services

Before anyone can use Spatial Web services, you, as an administrator with the DBA role, must ensure that:

- The `$ORACLE_HOME/md/jlib/sdows.ear` file is deployed into an OC4J instance.
- The necessary database connections are defined (if you accepted the default location for the `sdows.ear` file deployment) in the `<j2ee_home>/home/applications/sdows/META-INF/data-sources.xml` file. This file defines database connections available for use with all Web services, including OpenLS and WFS.

You should then examine and modify the `<j2ee_home>/home/applications/sdows/sdows/WEB-INF/conf/WSConfig.xml` file, which controls Web services behavior. [Example 10–1](#) shows the Oracle-supplied `WSConfig.xml` file, which you should modify as needed for your system environment. For more information about how to modify this and other files, see the `Readme.txt` file for the `wsclient.jar` demo file (described in [Section 10.4](#), "Demo Files for Sample Java Client").

Example 10–1 *WSConfig.xml File*

```
<?xml version="1.0"?>
<!-- This is the configuration file for Oracle 11g Spatial WS. -->
<!-- Note: All paths are resolved relative to where the WEB-INF directory
      is located, unless specified as an absolute path name.
-->

<WSConfig>

  <!-- ***** -->
  <!-- ***** Logging Settings ***** -->
  <!-- ***** -->

  <!-- Uncomment the following to modify logging. Possible values are:
        log_level = "fatal"|"error"|"warn"|"info"|"debug"|"finest"
                  default: info) ;
        log_thread_name = "true" | "false" ;
        log_time = "true" | "false" ;
        one or more log_output elements.
  -->
  <!--
    <logging log_level="info" log_thread_name="false"
              log_time="true">
      <log_output name="System.err" />
      <log_output name="log/ws.log" />
    </logging>
  -->

  <!-- ***** -->
  <!-- ***** WFS Cache Settings ***** -->
  <!-- ***** -->

  <!--
    Uncomment the cached_feature_types tag to specify the list of feature types that are cached.
    By default no feature types are cached.
  -->
  <!--
    <cached_feature_types>
  <feature_type ns="http://www.example.com/myns1" name="ROADS1" />
  <feature_type ns="http://www.example.com/myns2" name="HIGHWAYS" />
    </cached_feature_types>
  -->

  <!--
    Uncomment the wfs_cache_sync_interval tag to specify the interval in
    milliseconds in which the WFS Cache Synchronization thread will run.
    Default is 10000 millisec.
  -->
  <!--
    <wfs_cache_sync_interval>10000</wfs_cache_sync_interval>
  -->
```

```

<!-- ***** -->
<!-- ***** WFS Parameters***** -->
<!-- ***** -->

<!--
  Uncomment the wfs_admin_conn_name tag to specify the name of the connection in oc4j
  data-sources.xml configuration file for the spatial_wfs_admin_usr.
  Default value is jdbc/WFS_ADMIN_CONN_NAME.
-->
<!--
  <wfs_admin_conn_name>jdbc/WFS_ADMIN_CONN_NAME</wfs_admin_conn_name>
-->

<!--
  Uncomment the wfs_query_timeout tag to specify the query timeout value,
  which is used, when server-side locking API is called.
  The value of this tag can be a non-negative integer, and its unit is seconds.
  Default value is 10 seconds.
-->
<!--
  <wfs_query_timeout>10</wfs_query_timeout>
-->

<!--
  Uncomment the wfs_lock_expiry tag to configure the default wfs lock expiry value,
  which is the expiry time for wfs locks, if lock expiry value is not
  explicitly specified in GetFeatureWithLock or LockFeature requests.
  The value of this tag can be a non-negative integer, and its unit is minutes.
  Default value is 4 minutes.
-->
<!--
  <wfs_lock_expiry>4</wfs_lock_expiry>
-->

<!--
  Uncomment the wfs_xsd_loc_url tag to specify the URL of WFS / GML 2.1.2 specification XSDs on
  your server.
  This MUST be provided.
-->

<!--
  <wfs_xsd_loc_url>http://machine:port/xsds/</wfs_xsd_loc_url>
-->

<!--
  Uncomment the wfs_ex_xsd_loc_url tag to specify the URL of OGC Exception specification XSDs on
  your server.
  WFS Exceptions are reports as per this XSD. If this tag is not provided then it will be
  initialized with
  the value provided for wfs_xsd_loc_url (by default).
-->

<!--
  <wfs_ex_xsd_loc_url>http://machine:port/xsds/</wfs_ex_xsd_loc_url>
-->

```



```

    <!--
    Uncomment the gml3_xsd_loc_url tag to specify the URL of GML 3.1.1 specification XSDs on your
server.
    This is needed ONLY when using GML3.1.1.
    -->

    <!--
    <gml3_xsd_loc_url>http://machine:port/xsds/</gml3_xsd_loc_url>
    -->

<!-- ***** -->
<!-- ***** CSW Cache Settings ***** -->
<!-- ***** -->

<!--
<cached_record_types>
    <record_type ns="http://www.opengis.net/cat/csw" name="Record" />
</cached_record_types>
<csw_cache_sync_interval>10000</csw_cache_sync_interval>
<csw_cache_id>CSW_CACHE_ID</csw_cache_id>
-->

<!-- ***** -->
<!-- ***** CSW Parameters***** -->
<!-- ***** -->
<!--
    <csw_admin_conn_name>CSW_ADMIN_CONN_NAME</csw_admin_conn_name>
-->

    <!--
    Uncomment the csw_xsd_loc_url tag to specify the URL of CSW 2.0.0 specification XSDs on your
server.
    -->

    <!--
    <csw_xsd_loc_url>http://machine:port/xsds/</csw_xsd_loc_url>
    -->

    <!--
    Uncomment the csw_ex_xsd_loc_url tag to specify the URL of OWS Exception specification XSDs on
your server.
    CSW Exceptions are reports as per this XSD. If this tag is not provided then it will be
initialized with
    the value provided for csw_xsd_loc_url (by default).
    This MUST be provided if you are running CSW.
    -->
    <!--
    <csw_ex_xsd_loc_url>http://machine:port/xsds/</csw_ex_xsd_loc_url>
    -->

<!-- ***** -->
<!-- ***** Guest and XML user parameters ***** -->
<!-- ***** -->

<Handlers>
<OpenLS>
    <JavaClass> oracle.spatial.ws.openls.OpenLsHandler </JavaClass>
    <Anonymous_xml_user> SpatialWsXmlUser </Anonymous_xml_user>
    <Proxy_management>

```

```

    <Proxy_authentication/>

    <!--
    or
    <Application_user_management/>
    or
    <Fixed_app_user/>
    -->

  </Proxy_management>
</OpenLS>

<WFS>
  <JavaClass>          oracle.spatial.wfs.WFSHandler </JavaClass>
  <Anonymous_xml_user> SpatialWsXmlUser             </Anonymous_xml_user>
  <Proxy_management>  <Proxy_authentication/>      </Proxy_management>
</WFS>
<CSW>
  <JavaClass>          oracle.spatial.csw.CSWHandler </JavaClass>
  <Anonymous_xml_user> SpatialWsXmlUser             </Anonymous_xml_user>
  <Proxy_management>  <Proxy_authentication/>      </Proxy_management>
</CSW>
<SpatialWS_Sdo_Request>
  <JavaClass>          oracle.spatial.ws.svrproxy.SdoRequestHandler </JavaClass>
  <Anonymous_xml_user> SpatialWsXmlUser             </Anonymous_xml_user>
  <Proxy_management>  <Proxy_authentication/>      </Proxy_management>
</SpatialWS_Sdo_Request>
<SpatialWS_Sdo_Test_Request>
  <JavaClass>          oracle.spatial.ws.svrproxy.SdoTestRequestHandler </JavaClass>
  <Anonymous_xml_user> SpatialWsXmlUser             </Anonymous_xml_user>
  <Proxy_management>  <Proxy_authentication/>      </Proxy_management>
</SpatialWS_Sdo_Test_Request>
<Network>
  <JavaClass>          oracle.spatial.network.xml.NetworkWSHandler </JavaClass>
  <Proxy_management>  <Fixed_app_user/>            </Proxy_management>
</Network>
</Handlers>
</WSConfig>

```

You must also perform specific tasks that depend on which Web services you will be supporting for use in your environment. You will probably need to create and grant privileges to database users. You may need to download and load special data (such as for geocoding) or to modify configuration files. See the chapters on individual Web services for any specific requirements.

10.4 Demo Files for Sample Java Client

To help you get started with Spatial Web services, Oracle supplies a .jar file (`wsclient.jar`) with the source code and related files for setting up a sample Java client. To use this file, follow these steps:

1. Find `wsclient.jar` under the Spatial demo directory.
2. Expand (unzip) `wsclient.jar` into a directory of your choice.
The top-level directory for all the files in the .jar file is named `src`.
3. In the `src` directory, read the file named `Readme.txt` and follow its instructions.
The `Readme.txt` file contains detailed explanations and guidelines.

Geocoding Address Data

Geocoding is the process of associating spatial locations (longitude and latitude coordinates) with postal addresses. This chapter includes the following major sections:

- [Section 11.1, "Concepts for Geocoding"](#)
- [Section 11.2, "Data Types for Geocoding"](#)
- [Section 11.3, "Using the Geocoding Capabilities"](#)
- [Section 11.4, "Geocoding from a Place Name"](#)
- [Section 11.5, "Data Structures for Geocoding"](#)
- [Section 11.7, "Using the Geocoding Service \(XML API\)"](#)

11.1 Concepts for Geocoding

This section describes concepts that you must understand before you use the Spatial geocoding capabilities.

11.1.1 Address Representation

Addresses to be geocoded can be represented either as formatted addresses or unformatted addresses.

A **formatted address** is described by a set of attributes for various parts of the address, which can include some or all of those shown in [Table 11-1](#).

Table 11-1 *Attributes for Formal Address Representation*

Address Attribute	Description
Name	Place name (optional).
Intersecting street	Intersecting street name (optional).
Street	Street address, including the house or building number, street name, street type (Street, Road, Blvd, and so on), and possibly other information. In the current release, the first four characters of the street name must match a street name in the geocoding data for there to be a potential street name match.
Settlement	The lowest-level administrative area to which the address belongs. In most cases it is the city. In some European countries, the settlement can be an area within a large city, in which case the large city is the municipality.

Table 11–1 (Cont.) Attributes for Formal Address Representation

Address Attribute	Description
Municipality	The administrative area above settlement. Municipality is not used for United States addresses. In European countries where cities contain settlements, the municipality is the city.
Region	The administrative area above municipality (if applicable), or above settlement if municipality does not apply. In the United States, the region is the state; in some other countries, the region is the province.
Postal code	Postal code (optional if administrative area information is provided). In the United States, the postal code is the 5-digit ZIP code.
Postal add-on code	String appended to the postal code. In the United States, the postal add-on code is typically the last four numbers of a 9-digit ZIP code specified in "5-4" format.
Country	The country name or ISO country code.

Formatted addresses are specified using the SDO_GEO_ADDR data type, which is described in [Section 11.2.1](#).

An **unformatted address** is described using lines with information in the postal address format for the relevant country. The address lines must contain information essential for geocoding, and they might also contain information that is not needed for geocoding (something that is common in unprocessed postal addresses). An unformatted address is stored as an array of strings. For example, an address might consist of the following strings: '22 Monument Square' and 'Concord, MA 01742'.

Unformatted addresses are specified using the SDO_KEYWORDARRAY data type, which is described in [Section 11.2.3](#).

11.1.2 Match Modes

The match mode for a geocoding operation determines how closely the attributes of an input address must match the data being used for the geocoding. Input addresses can include different ways of representing the same thing (such as *Street* and the abbreviation *St*), and they can include minor errors (such as the wrong postal code, even though the street address and city are correct and the street address is unique within the city).

You can require an exact match between the input address and the data used for geocoding, or you can relax the requirements for some attributes so that geocoding can be performed despite certain discrepancies or errors in the input addresses. [Table 11–2](#) lists the match modes and their meanings. Use a value from this table with the `MatchMode` attribute of the SDO_GEO_ADDR data type (described in [Section 11.2.1](#)) and for the `match_mode` parameter of a geocoding function or procedure.

Table 11–2 Match Modes for Geocoding Operations

Match Mode	Description
EXACT	All attributes of the input address must match the data used for geocoding. However, if the house or building number, base name (street name), street type, street prefix, and street suffix do not all match the geocoding data, a location in the first match found in the following is returned: postal code, city or town (settlement) within the state, and state. For example, if the street name is incorrect but a valid postal code is specified, a location in the postal code is returned.

Table 11–2 (Cont.) Match Modes for Geocoding Operations

Match Mode	Description
RELAX_STREET_TYPE	The street type can be different from the data used for geocoding. For example, if <i>Main St</i> is in the data used for geocoding, <i>Main Street</i> would also match that, as would <i>Main Blvd</i> if there was no <i>Main Blvd</i> and no other street type named <i>Main</i> in the relevant area.
RELAX_POI_NAME	The name of the point of interest does not have to match the data used for geocoding. For example, if <i>Jones State Park</i> is in the data used for geocoding, <i>Jones State Pk</i> and <i>Jones Park</i> would also match as long as there were no ambiguities or other matches in the data.
RELAX_HOUSE_NUMBER	The house or building number and street type can be different from the data used for geocoding. For example, if <i>123 Main St</i> is in the data used for geocoding, <i>123 Main Lane</i> and <i>124 Main St</i> would also match as long as there were no ambiguities or other matches in the data.
RELAX_BASE_NAME	The base name of the street, the house or building number, and the street type can be different from the data used for geocoding. For example, if <i>Pleasant Valley</i> is the base name of a street in the data used for geocoding, <i>Pleasant Vale</i> would also match as long as there were no ambiguities or other matches in the data.
RELAX_POSTAL_CODE	The postal code (if provided), base name, house or building number, and street type can be different from the data used for geocoding.
RELAX_BUILTUP_AREA	The address can be outside the city specified as long as it is within the same county. Also includes the characteristics of RELAX_POSTAL_CODE.
RELAX_ALL	Equivalent to RELAX_BUILTUP_AREA.
DEFAULT	Equivalent to RELAX_POSTAL_CODE.

11.1.3 Match Codes

The match code is a number indicating which input address attributes matched the data used for geocoding. The match code is stored in the `MatchCode` attribute of the output `SDO_GEO_ADDR` object (described in [Section 11.2.1](#)).

[Table 11–3](#) lists the possible match code values.

Table 11–3 Match Codes for Geocoding Operations

Match Code	Description
1	Exact match: the city name, postal code, street base name, street type (and suffix or prefix or both, if applicable), and house or building number match the data used for geocoding.
2	The city name, postal code, street base name, and house or building number match the data used for geocoding, but the street type, suffix, or prefix does not match.
3	The city name, postal code, and street base name match the data used for geocoding, but the house or building number does not match.
4	The city name and postal code match the data used for geocoding, but the street address does not match.
10	The city name matches the data used for geocoding, but the postal code does not match.

Table 11–3 (Cont.) Match Codes for Geocoding Operations

Match Code	Description
11	The postal code matches the data used for geocoding, but the city name does not match.

11.1.4 Error Messages for Output Geocoded Addresses

Note: You are encouraged to use the `MatchVector` attribute (see [Section 11.1.5](#)) instead of the `ErrorMessage` attribute, which is described in this section.

For an output geocoded address, the `ErrorMessage` attribute of the `SDO_GEO_ADDR` object (described in [Section 11.2.1](#)) contains a string that indicates which address attributes have been matched against the data used for geocoding. Before the geocoding operation begins, the string is set to the value `??????????281C??`; and the value is modified to reflect which attributes have been matched.

[Table 11–4](#) lists the character positions in the string and the address attribute corresponding to each position. It also lists the character value that the position is set to if the attribute is matched.

Table 11–4 Geocoded Address Error Message Interpretation

Position	Attribute	Value If Matched
1-2	(Reserved for future use)	??
3	Address point	X
4	POI name	O
5	House or building number	#
6	Street prefix	E
7	Street base name	N
8	Street suffix	U
9	Street type	T
10	Secondary unit	S
11	Built-up area or city	B
12-13	(Reserved)	(Ignore any values in these positions.)
14	Region	1
15	Country	C
16	Postal code	P
17	Postal add-on code	A

11.1.5 Match Vector for Output Geocoded Addresses

For an output geocoded address, the `MatchVector` attribute of the `SDO_GEO_ADDR` object (described in [Section 11.2.1](#)) contains a string that indicates how each address attribute has been matched against the data used for geocoding. It gives more accurate

and detailed information about the match status of each address attribute than the `ErrorMessage` attribute (described in [Section 11.1.4](#)). Before the geocoding operation begins, the string is set to the value `????????????????`. Each character of this string indicates the match status of an address attribute.

[Table 11-5](#) lists the character positions in the string and the address attribute corresponding to each position. Following the table is an explanation of what the value in each character position represents.

Table 11-5 Geocoded Address Match Vector Interpretation

Position	Attribute
1-2	(Reserved for future use)
3	Address point
4	POI name
5	House or building number
6	Street prefix
7	Street base name
8	Street suffix
9	Street type
10	Secondary unit
11	Built-up area or city
14	Region
15	Country
16	Postal code
17	Postal add-on code

Each character position in [Table 11-5](#) can have one of the following possible numeric values:

- 0: The input attribute is not null and is matched with a non-null value.
- 1: The input attribute is null and is matched with a null value.
- 2: The input attribute is not null and is replaced by a different non-null value.
- 3: The input attribute is not null and is replaced by a null value.
- 4: The input attribute is null and is replaced by a non-null value.

11.2 Data Types for Geocoding

This section describes the data types specific to geocoding functions and procedures.

11.2.1 SDO_GEO_ADDR Type

The `SDO_GEO_ADDR` object type is used to describe an address. When a geocoded address is output by an `SDO_GCDR` function or procedure, it is stored as an object of type `SDO_GEO_ADDR`.

[Table 11-6](#) lists the attributes of the `SDO_GEO_ADDR` type. Not all attributes will be relevant in any given case. The attributes used for a returned geocoded address depend on the geographical context of the input address, especially the country.

Table 11–6 SDO_GEO_ADDR Type Attributes

Attribute	Data Type	Description
Id	NUMBER	(Not used.)
AddressLines	SDO_KEYWORDARRAY	Address lines. (The SDO_KEYWORDARRAY type is described in Section 11.2.3 .)
PlaceName	VARCHAR2(200)	Point of interest (POI) name. Example: <i>CALIFORNIA PACIFIC MEDICAL CTR</i>
StreetName	VARCHAR2(200)	Street name, including street type. Example: <i>MAIN ST</i>
IntersectStreet	VARCHAR2(200)	Intersecting street.
SecUnit	VARCHAR2(200)	Secondary unit, such as an apartment number or building number.
Settlement	VARCHAR2(200)	Lowest-level administrative area to which the address belongs. (See Table 11–1 .)
Municipality	VARCHAR2(200)	Administrative area above settlement. (See Table 11–1 .)
Region	VARCHAR2(200)	Administrative area above municipality (if applicable), or above settlement if municipality does not apply. (See Table 11–1 .)
Country	VARCHAR2(100)	Country name or ISO country code.
PostalCode	VARCHAR2(20)	Postal code (optional if administrative area information is provided). In the United States, the postal code is the 5-digit ZIP code.
PostalAddOnCode	VARCHAR2(20)	String appended to the postal code. In the United States, the postal add-on code is typically the last four numbers of a 9-digit ZIP code specified in "5-4" format.
FullPostalCode	VARCHAR2(20)	Full postal code, including the postal code and postal add-on code.
POBox	VARCHAR2(100)	Post Office box number.
HouseNumber	VARCHAR2(100)	House or building number. Example: <i>123</i> in <i>123 MAIN ST</i>
BaseName	VARCHAR2(200)	Base name of the street. Example: <i>MAIN</i> in <i>123 MAIN ST</i>
StreetType	VARCHAR2(20)	Type of the street. Example: <i>ST</i> in <i>123 MAIN ST</i>
StreetTypeBefore	VARCHAR2(1)	(Not used.)
StreetTypeAttached	VARCHAR2(1)	(Not used.)
StreetPrefix	VARCHAR2(20)	Prefix for the street. Example: <i>S</i> in <i>123 S MAIN ST</i>
StreetSuffix	VARCHAR2(20)	Suffix for the street. Example: <i>NE</i> in <i>123 MAIN ST NE</i>
Side	VARCHAR2(1)	Side of the street (L for left or R for right) that the house is on when you are traveling along the road segment following its orientation (that is, from its start node toward its end node). The house numbers may be increasing or decreasing.

Table 11–6 (Cont.) SDO_GEO_ADDR Type Attributes

Attribute	Data Type	Description
Percent	NUMBER	Number from 0 to 1 (multiply by 100 to get a percentage value) indicating how far along the street you are when traveling following the road segment orientation.
EdgeID	NUMBER	Edge ID of the road segment.
ErrorMessage	VARCHAR2(20)	Error message (see Section 11.1.4). Note: You are encouraged to use the <code>MatchVector</code> attribute instead of the <code>ErrorMessage</code> attribute.
MatchCode	NUMBER	Match code (see Section 11.1.3).
MatchMode	VARCHAR2(30)	Match mode (see Section 11.1.2).
Longitude	NUMBER	Longitude coordinate value.
Latitude	NUMBER	Latitude coordinate value.
MatchVector	VARCHAR2(20)	A string that indicates how each address attribute has been matched against the data used for geocoding (see Section 11.1.5).

You can return the entire `SDO_GEO_ADDR` object, or you can specify an attribute using standard "dot" notation. [Example 11–1](#) contains statements that geocode the address of the San Francisco City Hall; the first statement returns the entire `SDO_GEO_ADDR` object, and the remaining statements return some specific attributes.

Example 11–1 Geocoding, Returning Address Object and Specific Attributes

```

SELECT SDO_GCDR.GEOCODE('SCOTT',
  SDO_KEYWORDARRAY('1 Carlton B Goodlett Pl', 'San Francisco, CA 94102'),
  'US', 'RELAX_BASE_NAME') FROM DUAL;

SDO_GCDR.GEOCODE('SCOTT',SDO_KEYWORDARRAY('1CARLTONBGGOODLETTPL', 'SANFRANCISCO
-----
SDO_GEO_ADDR(0, SDO_KEYWORDARRAY(), NULL, 'CARLTON B GOODLETT PL', NULL, NULL, '
SAN FRANCISCO', NULL, 'CA', 'US', '94102', NULL, '94102', NULL, '1', 'CARLTON B
GOODLETT', 'PL', 'F', 'F', NULL, NULL, 'L', .01, 23614360, '????#ENUT?B281CP?',
1, 'RELAX_BASE_NAME', -122.41815, 37.7784183, '????0101010??000?')

SELECT SDO_GCDR.GEOCODE('SCOTT',
  SDO_KEYWORDARRAY('1 Carlton B Goodlett Pl', 'San Francisco, CA 94102'),
  'US', 'RELAX_BASE_NAME').StreetType FROM DUAL;

SDO_GCDR.GEOCODE('SCOTT',SDO_KEYWORDARRAY('1CARLTONBGGOODLETTPL', 'SANFRANCISCO
-----
PL

SELECT SDO_GCDR.GEOCODE('SCOTT',
  SDO_KEYWORDARRAY('1 Carlton B Goodlett Pl', 'San Francisco, CA 94102'),
  'US', 'RELAX_BASE_NAME').Side FROM DUAL;

S
-
L

SELECT SDO_GCDR.GEOCODE('SCOTT',
  SDO_KEYWORDARRAY('1 Carlton B Goodlett Pl', 'San Francisco, CA 94102'),
  'US', 'RELAX_BASE_NAME').Percent FROM DUAL;

```

```

SDO_GCDR.GEocode('SCOTT',SDO_KEYWORDARRAY('1CARLTONBGODLETTPL','SANFRANCISCO
-----
.01

SELECT SDO_GCDR.GEocode('SCOTT',
  SDO_KEYWORDARRAY('1 Carlton B Goodlett Pl', 'San Francisco, CA 94102'),
  'US', 'RELAX_BASE_NAME').EdgeID FROM DUAL;

SDO_GCDR.GEocode('SCOTT',SDO_KEYWORDARRAY('1CARLTONBGODLETTPL','SANFRANCISCO
-----
23614360

SELECT SDO_GCDR.GEocode('SCOTT',
  SDO_KEYWORDARRAY('1 Carlton B Goodlett Pl', 'San Francisco, CA 94102'),
  'US', 'RELAX_BASE_NAME').MatchCode FROM DUAL;

SDO_GCDR.GEocode('SCOTT',SDO_KEYWORDARRAY('1CARLTONBGODLETTPL','SANFRANCISCO
-----
1

SELECT SDO_GCDR.GEocode('SCOTT',
  SDO_KEYWORDARRAY('1 Carlton B Goodlett Pl', 'San Francisco, CA 94102'),
  'US', 'RELAX_BASE_NAME').MatchVector FROM DUAL;

SDO_GCDR.GEocode('SC
-----
????0101010??000?

```

11.2.2 SDO_ADDR_ARRAY Type

The SDO_ADDR_ARRAY type is a VARRAY of SDO_GEO_ADDR objects (described in [Section 11.2.1](#)) used to store geocoded address results. Multiple address objects can be returned when multiple addresses are matched as a result of a geocoding operation.

The SDO_ADDR_ARRAY type is defined as follows:

```
CREATE TYPE sdo_addr_array AS VARRAY(1000) OF sdo_geo_addr;
```

11.2.3 SDO_KEYWORDARRAY Type

The SDO_KEYWORDARRAY type is a VARRAY of VARCHAR2 strings used to store address lines for unformatted addresses. (Formatted and unformatted addresses are described in [Section 11.1.1](#).)

The SDO_KEYWORDARRAY type is defined as follows:

```
CREATE TYPE sdo_keywordarray AS VARRAY(10000) OF VARCHAR2(9000);
```

11.3 Using the Geocoding Capabilities

To use the Oracle Spatial geocoding capabilities, you must use data provided by a geocoding vendor, and the data must be in the format supported by the Oracle Spatial geocoding feature. For information about getting and loading this data, go to the Spatial page of the Oracle Technology Network (OTN):

<http://www.oracle.com/technology/products/spatial/>

Find the link for geocoding, and follow the instructions.

To geocode an address using the geocoding data, use the `SDO_GCDR` PL/SQL package subprograms, which are documented in [Chapter 23](#):

- The `SDO_GCDR.GEOCODE` function geocodes an unformatted address to return an `SDO_GEO_ADDR` object.
- The `SDO_GCDR.GEOCODE_ADDR` function geocodes an input address using attributes in an `SDO_GEO_ADDR` object, and returns the first matched address as an `SDO_GEO_ADDR` object.
- The `SDO_GCDR.GEOCODE_ADDR_ALL` function geocodes an input address using attributes in an `SDO_GEO_ADDR` object, and returns matching addresses as an `SDO_ADDR_ARRAY` object.
- The `SDO_GCDR.GEOCODE_AS_GEOMETRY` function geocodes an unformatted address to return an `SDO_GEOMETRY` object.
- The `SDO_GCDR.GEOCODE_ALL` function geocodes all addresses associated with an unformatted address and returns the result as an `SDO_ADDR_ARRAY` object (an array of address objects).
- The `SDO_GCDR.REVERSE_GEOCODE` function reverse geocodes a location, specified by its spatial geometry object and country, and returns the result as an `SDO_GEO_ADDR` object.

11.4 Geocoding from a Place Name

If you know a place name (point of interest) but not its locality details, you can create a PL/SQL function to construct an `SDO_GEO_ADDR` object from `placename` and `country` input parameters, as shown in [Example 11-2](#), which creates a function named `create_addr_from_placename`. The `SELECT` statement in this example uses the `SDO_GCDR.GEOCODE_ADDR` function to geocode the address constructed using the `create_addr_from_placename` function.

Example 11-2 Geocoding from a Place Name and Country

```
create or replace function create_addr_from_placename(
  placename varchar2,
  country varchar2)
return sdo_geo_addr
deterministic
as
  addr sdo_geo_addr ;
begin
  addr := sdo_geo_addr() ;
  addr.country := country ;
  addr.placename := placename ;
  addr.matchmode := 'default' ;
  return addr ;
end;
/

SELECT sdo_gcdr.geocode_addr('SCOTT',
  create_addr_from_placename('CALIFORNIA PACIFIC MEDICAL CTR', 'US'))
FROM DUAL;
```

If you know at least some of the locality information, such as settlement, region, and postal code, you can get better performance if you can provide such information. [Example 11-3](#) provides an alternate version of the `create_addr_from_placename` function that accepts additional parameters. To call this version of the function, specify

actual values for the placename and country parameters, and specify an actual value or a null value for each of the other input parameters.

Example 11–3 Geocoding from a Place Name, Country, and Other Fields

```
create or replace function create_addr_from_placename(
placename varchar2,
city varchar2,
state varchar2,
postalcode varchar2,
country varchar2)
return sdo_geo_addr
deterministic
as
    addr sdo_geo_addr ;
begin
    addr := sdo_geo_addr() ;
    addr.settlement := city ;
    addr.region := state ;
    addr.postalcode := postalcode ;
    addr.country := country ;
    addr.placename := placename ;
    addr.matchmode := 'default' ;
    return addr ;
end;
/

SELECT sdo_gcdr.geocode_addr('SCOTT',
    create_addr_from_placename('CALIFORNIA PACIFIC MEDICAL CTR',
        'san francisco', 'ca', null, 'US')) FROM DUAL;
```

11.5 Data Structures for Geocoding

Oracle uses the following tables for geocoding:

- GC_PARSER_PROFILES
- GC_PARSER_PROFILEAFS
- GC_COUNTRY_PROFILE
- GC_AREA_<suffix>
- GC_POSTAL_CODE_<suffix>
- GC_ROAD_SEGMENT_<suffix>
- GC_ROAD_<suffix>
- GC_POI_<suffix>
- GC_INTERSECTION_<suffix>

The GC_PARSER_PROFILES and GC_PARSER_PROFILEAFS tables store address format definitions of all supported counties. These tables are used by the internal address parser in parsing postal addresses into addressing fields. The data for these two tables is provided by your data provider or by Oracle. (If these tables are not supplied by your data provider, you will need to install and populate them as explained in [Section 11.6](#).) The remaining tables store geocoding data provided by data vendors.

Each user that owns the tables containing geocoding data (that is, each user that can be specified with the `username` parameter in a call to an SDO_GCDR subprogram) must

have one GC_PARSER_PROFILES table, one GC_PARSER_PROFILEAFS table, and one GC_COUNTRY_PROFILE table. Each such user can have multiple sets of the other tables (GC_<xxx_<suffix>). Each set of tables whose names end with the same suffix stores geocoding data of a country. For example, the following set of tables can be used to store geocoding data of the United States:

- GC_AREA_US
- GC_POSTAL_CODE_US
- GC_ROAD_SEGMENT_US
- GC_ROAD_US
- GC_POI_US
- GC_INTERSECTION_US

Geocoding data of one country cannot be stored in more than one set of those tables. The table suffix is defined by data vendors and is specified in the GC_TABLE_SUFFIX column in the GC_COUNTRY_PROFILE table (described in [Section 11.5.3](#)).

The following sections describe the vendor-supplied tables that store geocoding data, in alphabetical order by table name.

[Section 11.5.11](#) describes the indexes that you must create in order to use these tables for geocoding.

11.5.1 GC_ADDRESS_POINT_<suffix> Table and Index

The GC_ADDRESS_POINT_<suffix> table (for example, GC_ADDRESS_POINT_US) stores the geographic (latitude, longitude) coordinates for addresses in the country or group of countries associated with the table-name suffix. This table is *not* required for geocoding (although it is required for point-based geocoding); however, it enables the geocoder to provide more accurate location results. It is automatically used when present in the schema. This table contains one row for each address stored in the table, and it contains the columns shown in [Table 11–7](#).

Table 11–7 GC_ADDRESS_POINT_<suffix> Table

Column Name	Data Type	Description
ADDRESS_POINT_ID	NUMBER(10)	ID number of the address point. (Required)
ROAD_ID	NUMBER	ID number of the road on which the address point is located. (Required)
ROAD_SEGMENT_ID	NUMBER(10)	ID number of the road segment on the road on which the address point is located. (Required)
SIDE	VARCHAR2(1)	Side of the road on which the address point is located. Possible values: L (left) or R (right). (Required)
LANG_CODE	VARCHAR2(3)	3-letter ISO national language code for the language associated with the address point. (Required) point
HOUSE_NUMBER	VARCHAR2(600 CHAR)	House number of the address point; may contain non-numeric characters. (Required)
PERCENT	NUMBER	Decimal fraction of the length of the road segment on which the address point is located. It is computed by dividing the distance from the segment start point to the address point by the length of the road segment. (Required).

Table 11–7 (Cont.) GC_ADDRESS_POINT_<suffix> Table

Column Name	Data Type	Description
ADDR_LONG	NUMBER(10)	Longitude coordinate value of the address point. (Required)
ADDR_LAT	NUMBER(10)	Latitude coordinate value of the address point. (Required)
COUNTRY_CODE_2	VARCHAR2(2)	2- letter ISO country code of the country to which the address point belongs. (Required)
PARTITION_ID	NUMBER	Partition key used for partitioning geocoder data by geographic boundaries. If the data is not partitioned, set the value to 1. (Required)

If you use the GC_ADDRESS_POINT_<suffix> table, you must create an index on the table using a statement in the following form:

```
CREATE INDEX idx_<suffix>_addrpt_addr ON gc_address_point_<suffix> (road_segment_id, road_id, house_number, side);
```

11.5.2 GC_AREA_<suffix> Table

The GC_AREA_<suffix> table (for example, CG_AREA_US) stores administration area information for the country associated with the table name suffix. This table contains one row for each administration area, and it contains the columns shown in [Table 11–8](#).

Table 11–8 GC_AREA_<suffix> Table

Column Name	Data Type	Description
AREA_ID	NUMBER(10)	Area ID number. (Required)
AREA_NAME	VARCHAR2(64)	Area name. (Required)
LANG_CODE	VARCHAR2(3)	3-letter ISO national language code for the language associated with the area. (Required)
ADMIN_LEVEL	NUMBER(1)	Administration hierarchy level for the area. (Required)
LEVEL1_AREA_ID	NUMBER(10)	ID of the level-1 area to which the area belongs. In the administration hierarchy, the level-1 area is the country. (Required)
LEVEL2_AREA_ID	NUMBER(10)	ID of the level-2 area to which the area belongs, if applicable. You must specify an area ID for each level in the administration hierarchy to which this area belongs. (Optional)
LEVEL3_AREA_ID	NUMBER(10)	ID of the level-3 area to which the area belongs, if applicable. You must specify an area ID for each level in the administration hierarchy to which this area belongs. (Optional)
LEVEL4_AREA_ID	NUMBER(10)	ID of the level-4 area to which the area belongs, if applicable. You must specify an area ID for each level in the administration hierarchy to which this area belongs. (Optional)
LEVEL5_AREA_ID	NUMBER(10)	ID of the level-5 area to which the area belongs, if applicable. You must specify an area ID for each level in the administration hierarchy to which this area belongs. (Optional)

Table 11–8 (Cont.) GC_AREA_<suffix> Table

Column Name	Data Type	Description
LEVEL6_AREA_ID	NUMBER(10)	ID of the level-6 area to which the area belongs, if applicable. You must specify an area ID for each level in the administration hierarchy to which this area belongs. (Optional)
LEVEL7_AREA_ID	NUMBER(10)	ID of the level-7 area to which the area belongs, if applicable. You must specify an area ID for each level in the administration hierarchy to which this area belongs. (Optional)
CENTER_LONG	NUMBER	Longitude value of the center of the area. The center is set to the closest road segment to the center longitude and latitude values. Oracle recommends that these two attributes be set properly. If these values are not set, the longitude and latitude coordinates of the geocoded result of an area will be (0,0). (Optional)
CENTER_LAT	NUMBER	Latitude value of the center of the area. (See the explanation for the CENTER_LONG column.) (Optional)
ROAD_SEGMENT_ID	NUMBER(10)	ID of the road segment to which the area center is set. This value must be set correctly if the geocoder is intended to work with the Oracle Spatial routing engine (described in Chapter 13); otherwise, it can be set to any nonzero value, but it cannot be null. (Required)
POSTAL_CODE	VARCHAR2(16)	Postal code for the center of the area. Oracle recommends that this attribute be set correctly. If this value is null, the postal code attribute of the geocoded result of an area will be null. (Optional)
COUNTRY_CODE_2	VARCHAR2(2)	2- letter ISO country code of the country to which the area belongs. (Required)
PARTITION_ID	NUMBER	Partition key used for partitioning geocoder data by geographic boundaries. If the data is not partitioned, set the value to 1. (Required)
REAL_NAME	VARCHAR2(64)	The real name of the area, as spelled using the local language. This column is useful for area names that are not in English. For example, the German name of city MUNICH is MÜNCHEN. It is allowed to be spelled as MUNCHEN, but its REAL_NAME value should be MÜNCHEN. In the area table for Germany, areas with name MÜNCHEN and MUNCHEN both refer to the same area, and they both have the same real name MÜNCHEN. If the area name does not have any non-English characters, set REAL_NAME to be the same as AREA_NAME. (Required)
IS_ALIAS	VARCHAR2(1)	Contains T if this area is an alias of another area that is an officially recognized administrative area; contains F if this area is not an alias of another area that is an officially recognized administrative area. For example, Manhattan is not an officially recognized administrative area, but it is used by the public to refer to a part of New York City. In this case, Manhattan is an alias of New York City. (Required)
NUM_STREETS	NUMBER	The number of streets inside this area. (Optional)

11.5.3 GC_COUNTRY_PROFILE Table

The GC_COUNTRY_PROFILE table stores country profile information used by the geocoder. This information includes administrative-area hierarchy definitions, the national languages, and the table-name suffix used by the data tables and their indexes. This table contains one row for each supported country, and it contains the columns shown in [Table 11–9](#).

Table 11–9 GC_COUNTRY_PROFILE Table

Column Name	Data Type	Description
COUNTRY_NAME	VARCHAR2(60)	Country name. (Required)
COUNTRY_CODE_3	VARCHAR2(3)	3- letter ISO country code. (Required)
COUNTRY_CODE_2	VARCHAR2(2)	2- letter ISO country code. (Required)
LANG_CODE_1	VARCHAR2(3)	3-letter ISO national language code. Some countries might have multiple national languages, in which case LANG_CODE_2 and perhaps other LANG_CODE_n columns should contain values. (Required)
LANG_CODE_2	VARCHAR2(3)	3-letter ISO national language code. (Optional)
LANG_CODE_3	VARCHAR2(3)	3-letter ISO national language code. (Optional)
LANG_CODE_4	VARCHAR2(3)	3-letter ISO national language code. (Optional)
NUMBER_ADMIN_LEVELS	NUMBER(1)	Number of administration hierarchy levels. A country can have up to 7 administration area levels, numbered from 1 to 7 (largest to smallest). The top level area (country) is level 1. For the United States, the administration hierarchy is as follows: level 1 = country, level 2 = state, level 3 = county, level 4 = city. (Required)
SETTLEMENT_LEVEL	NUMBER(1)	Administration hierarchy level for a settlement, which is the lowest area level used in addressing. In the United States, this is the city level; in Europe, this is generally a subdivision of a city (level 5). (Required)
MUNICIPALITY_LEVEL	NUMBER(1)	Administration hierarchy level for a municipality, which is the second-lowest area level used in addressing. In the United States, this is the county (level 3); in Europe, this is generally a city (level 4). (Optional)
REGION_LEVEL	NUMBER(1)	Administrative level for the region, which is above the municipality level. In the United States, this is the state or third-lowest area level used in addressing (level 2); in Europe, this is a recognized subdivision of the country (level 2 or level 3). (Optional)
SETTLEMENT_IS_OPTIONAL	VARCHAR2(1)	Contains T if settlement information is optional in the address data; contains F if settlement information is not optional (that is, is required) in the address data. (Required)
MUNICIPALITY_IS_OPTIONAL	VARCHAR2(1)	Contains T if municipality information is optional in the address data; contains F if municipality information is not optional (that is, is required) in the address data. (Required)

Table 11–9 (Cont.) GC_COUNTRY_PROFILE Table

Column Name	Data Type	Description
REGION_IS_OPTIONAL	VARCHAR2(1)	Contains T if region information is optional in the address data; contains F if region information is not optional (that is, is required) in the address data. (Required)
POSTCODE_IN_SETTLEMENT	VARCHAR(1)	Contains T if each postal code must be completely within a settlement area; contains F if a postal code can include areas from multiple settlements. (Required)
SETTLEMENT_AS_CITY	VARCHAR(1)	Contains T if a city name can identify both a municipality and a settlement; contains F if a city name can identify only a settlement. For example, in the United Kingdom, London can be both the name of a municipality area and the name of a settlement area, which is inside the municipality of London. This is common in large cities in some European countries, such as the UK and Belgium. (Required)
CACHED_ADMIN_AREA_LEVEL	NUMBER	(Reserved for future use.)
GC_TABLE_SUFFIX	VARCHAR2(5)	Table name suffix identifying the country for the GC_* data tables. For example, if the value of GC_TABLE_SUFFIX is US, the names of tables with geocoding data for this country end with _US (for example, CG_AREA_US). (Required)
CENTER_LONG	NUMBER	Longitude value of the center of the area. (Optional)
CENTER_LAT	NUMBER	Latitude value of the center of the area. (Optional)
SEPARATE_PREFIX	VARCHAR2(1)	Contains T if the street name prefix is a separate word from the street name; contains F if the street name prefix is in the same word with the street name. For example, in an American street address of 123 N Main St, the prefix is N, and it is separate from the street name, which is Main. (Optional; not currently used by Oracle)
SEPARATE_SUFFIX	VARCHAR2(1)	Contains T if the street name suffix is a separate word from the street name; contains F if the street name suffix is in the same word with the street name. For example, in an American street address of 123 Main St NW, the suffix is NW, and it is separate from the street name, which is Main, and from the street type, which is St. (Optional; not currently used by Oracle)
SEPARATE_STYPE	VARCHAR2(1)	Contains T if the street type is a separate word from the street name; contains F if the street type is in the same word with the street name. For example, in a German street address of 123 Beethovenstrass, the type is strass, and it is in the same word with the street name, which is Beethoven. (Optional; not currently used by Oracle)
AREA_ID	NUMBER	Not currently used by Oracle. (Optional)
VERSION	VARCHAR2(10)	Version of the data. The first version should be 1.0. (Required)

11.5.4 GC_INTERSECTION_<suffix> Table

The GC_INTERSECTION_<suffix> table (for example, GC_INTERSECTION_US) stores information on road intersections for the country or group of countries

associated with the table-name suffix. An intersection occurs when roads meet or cross each other. This table contains the columns shown in [Table 11–10](#).

Table 11–10 *GC_INTERSECTION_<suffix> Table*

Column Name	Data Type	Description
ROAD_ID_1	NUMBER	ID number of the first road on which the intersection is located. (Required)
ROAD_SEGMENT_ID_1	NUMBER	ID number of the road segment on the first road on which the intersection is located. (Required)
ROAD_ID_2	NUMBER	ID number of the second road on which the intersection is located. (Required)
ROAD_SEGMENT_ID_2	NUMBER	ID number of the road segment on the second road on which the intersection is located. (Required)
INTS_LONG	NUMBER	Longitude coordinate value of the intersection. (Required)
INTS_LAT	NUMBER	Latitude coordinate value of the intersection. (Required)
HOUSE_NUMBER	NUMBER	The leading numerical part of the house number at the intersection. (See the explanation of house numbers after Table 11–16 in Section 11.5.10 .) (Required)
HOUSE_NUMBER_2	VARCHAR2(10)	The second part of the house number at the intersection. (See the explanation of house numbers after Table 11–16 in Section 11.5.10 .) (Required)
SIDE	VARCHAR2(1)	Side of the street on which the house at the intersection is located. Possible values: L (left) or R (right). (Required)
COUNTRY_CODE_2	VARCHAR2(2)	2- letter ISO country code of the country to which the house at the intersection belongs. (Required)
PARTITION_ID	NUMBER	Partition key used for partitioning geocoder data by geographic boundaries. If the data is not partitioned, set the value to 1. (Required)

11.5.5 GC_PARSER_PROFILES Table

The GC_PARSER_PROFILES table stores information about keywords typically found in postal addresses. The geocoder uses keywords to identify address fields, such as house number, road name, city name, state name, and postal code. A keyword can be the type of street (such as road, street, drive, or avenue) or the prefix or suffix of a street (such as north, south, east, or west). This table contains the columns shown in [Table 11–11](#).

Table 11–11 *GC_PARSER_PROFILES Table*

Column Name	Data Type	Description
COUNTRY_CODE	VARCHAR2(2)	2- letter ISO country code of the country for the keyword. (Required)

Table 11–11 (Cont.) GC_PARSER_PROFILES Table

Column Name	Data Type	Description
KEYWORDS	SDO_KEYWORDARRAY	<p>A single array of keywords for a specific address field. The array may contain a single word, or a group of words and abbreviations that can be used with the same meaning; for example, <i>United States of America</i>, <i>USA</i>, and <i>United States</i> all refer to the US. The first word of this array should be the official full name of the keyword, if there is any. The US uses over 400 keywords in parsing addresses. The following are some examples of keyword arrays and keywords from the US data set; however, only a single SDO_KEYWORDARRAY object is stored in each row:</p> <p>SDO_KEYWORDARRAY('UNITED STATES OF AMERICA','US', 'USA', 'UNITED STATES', 'U.S.A.', 'U.S.')</p> <p>SDO_KEYWORDARRAY('AVENUE','AV', 'AVE', 'AVEN', 'AVENU', 'AVN', 'AVNUE', 'AV.', 'AVE.')</p> <p>SDO_KEYWORDARRAY('40TH', 'FORTIETH')</p> <p>SDO_KEYWORDARRAY('NEW YORK','NY')</p> <p>SDO_KEYWORDARRAY('LIBRARY')</p>
OUTPUT_KEYWORD	VARCHAR2(2000)	<p>A keyword used in the geocoder data to represent an address field. It must be the same as one of the keywords used in the keyword array. The output keyword is used to match the addresses stored in the geocoding data tables to the user's input, for example, if the output keyword <i>AV</i> is used for street type <i>Avenue</i> in the <i>GC_ROAD_US</i> table, wherever a user enters an address containing any of the keywords (<i>AVENUE</i>, <i>AV</i>, <i>AVE</i>, <i>AVEN</i>, <i>AVENU</i>, <i>AVN</i>, <i>AVNUE</i>, <i>AV.</i>, <i>AVE.</i>), the keyword will be interpreted and matched to the output keyword <i>AV</i> to help find the address in the database. The following are some examples of output keywords; however, only a single output keyword is stored in each row:</p> <p>US</p> <p>AV</p> <p>40TH</p> <p>NY</p> <p>LIBRARY</p>

Table 11–11 (Cont.) GC_PARSER_PROFILES Table

Column Name	Data Type	Description
SECTION_LABEL	VARCHAR2(30)	<p>A label used to identify the type of keyword represented in the KEYWORDS and OUTPUT_KEYWORD columns. There are the multiple different section labels; however, only a single section label for each row is used in identifying the type of keywords:</p> <p>COUNTRY_NAME: Identifies keywords that are used to represent country names.</p> <p>LOCALITY_KEYWORD_DICTIONARY: Identifies keywords that are used to replace words in a locality (city, state, province, and so on) with a standardized form of the word. For example, <i>Saint</i> is replaced by <i>St</i>; and by doing so, the city names <i>Saint Thomas</i> and <i>St. Thomas</i> will be standardized to <i>St Thomas</i>, which is stored in the database.</p> <p>PLACE_NAME_KEYWORD: Identifies a point of interest (POI) name keyword, such as for a restaurant or a hotel.</p> <p>REGION_LIST: Identifies keywords that are known names of regions, such as <i>NY</i>, <i>New York</i>, <i>NH</i>, and <i>New Hampshire</i>. The regions identified must be administrative areas that belong to the third-lowest area level or third-smallest area used in addressing. In the US this is the state level (the lowest area level or smallest area is the city level).</p> <p>SECOND_UNIT_KEYWORD: Identifies keywords used in second-unit descriptions, such as <i>Floor</i>, <i>#</i>, <i>Suite</i>, and <i>Apartment</i>.</p> <p>STREET_KEYWORD_DICTIONARY: Identifies keywords used to replace non-street-type keywords in street names (such as <i>40TH</i> and <i>Fortieth</i>) with a standardized form.</p> <p>STREET_PREFIX_KEYWORD: Identifies street name prefix keywords, such as <i>South</i>, <i>North</i>, <i>West</i>, and <i>East</i>.</p> <p>STREET_TYPE_KEYWORD: Identifies street type keywords, such as <i>Road</i>, <i>Street</i>, and <i>Drive</i>.</p> <p>IN_LINE_STREET_TYPE_KEYWORD: Identifies street type keywords that are attached to street names, such as <i>strasse</i> in the German street name <i>Steinstrasse</i>.</p>
POSITION	VARCHAR2(1)	<p>The position of the keyword relative to a street name. It indicates whether the keyword can precede (P) or follow (F) the actual street name, or both (B). Thus, P, F, and B are the only valid entries. In the US, most street type keywords follow the street names, for example, the street type <i>B1vd</i> in <i>Hollywood Blvd</i>. In France, however, street type keywords usually precede the street names, for example, the street type <i>Avenue</i> in <i>Avenue De Paris</i>.</p>
SEPARATENESS	VARCHAR2(1)	<p>Indicates whether the keyword is separate from a street name. Keywords are either separable (S) or non-separable (N). Thus, S and N are the only valid entries. In the US, all street-type keywords are separate words from the street name, for example, the street type <i>B1vd</i> in <i>Hollywood Blvd</i>. In Germany, however, the street-type keywords are not separate from the street name, for example, the street type <i>strasse</i> in <i>Augustenstrasse</i>.</p>

11.5.6 GC_PARSER_PROFILEAFS Table

The GC_PARSER_PROFILEAFS table stores the XML definition of postal-address formats. An XML string describes each address format for a specific country. In the Oracle Geocoder 10g and earlier, the J2EE geocoder uses a country_name.ppr file instead of this table. The content of the country_name.ppr file is equivalent to the content of the ADDRESS_FORMAT_STRING attribute. This table contains the columns shown in [Table 11-12](#).

Table 11-12 GC_PARSER_PROFILEAFS Table

Column Name	Data Type	Description
COUNTRY_CODE	VARCHAR2(2)	2- letter ISO country code of the country. (Required)
ADDRESS_FORMAT_STRING	CLOB	XML string describing the address format for the country specified in the COUNTRY_CODE column. (Example 11-4 shows the XML definition for the US address format, and Section 11.5.6.1 explains the elements used in the US address format definition.)

[Example 11-4](#) shows the ADDRESS_FORMAT_STRING definition for the US address format.

Example 11-4 XML Definition for the US Address Format

```
<address_format unit_separator="," replace_hyphen="true">
  <address_line>
    <place_name />
  </address_line>
  <address_line>
    <street_address>
      <house_number>
        <format form="0*" effective="0-1" output="$" />
        <format form="0*1*" effective="0-1" output="$">
          <exception form="0*TH" />
          <exception form="0*ST" />
          <exception form="0*2ND" />
          <exception form="0*3RD" />
        </format>
        <format form="0*10*" effective="0-1" output="$" />
        <format form="0*-0*" effective="0-1" output="$" />
        <format form="0*.0*" effective="0-1" output="$" />
        <format form="0* 0*/0*" effective="0-1" output="$" />
      </house_number>
      <street_name>
        <prefix />
        <base_name />
      <suffix />
      <street_type />
      <special_format>
        <format form="1* HWY 0*" effective="7-8" addon_effective="0-1" addon_output="$ HWY"/>
        <format form="1* HIGHWAY 0*" effective="11-12" addon_effective="0-1" addon_output="$ HWY"/>
        <format form="1* HWY-0*" effective="7-8" addon_effective="0-1" addon_output="$ HWY"/>
        <format form="1* HIGHWAY-0*" effective="11-12" addon_effective="0-1" addon_output="$ HWY"/>
        <format form="HWY 0*" effective="4-5" addon_output="HWY" />
        <format form="HIGHWAY 0*" effective="8-9" addon_output="HWY" />
      </special_format>
    </street_address>
  </address_line>
</address_format>
```

```

    <format form="ROUTE 0*" effective="6-7" addon_output="RT" />
    <format form="I 0*" effective="2-3" addon_output="I" />
    <format form="11 0*" effective="3-4" addon_effective="0-1" />
    <format form="I0*" effective="1-2" addon_output="I" />
    <format form="I-0*" effective="2-3" addon_output="I" />
    <format form="11-0*" effective="3-4" addon_effective="0-1" />
    <format form="ROUTE-0*" effective="6-7" addon_output="RT" />
    <format form="US0*" effective="2-3" addon_output="US" />
    <format form="HWY-0*" effective="2-3" addon_output="US" />
    <format form="HIGHWAY-0*" effective="8-9" addon_output="HWY" />
  </special_format>
</street_name>
<second_unit>
  <special_format>
    <format form="# 0*" effective="2-3" output="APT $" />
    <format form="#0*" effective="1-2" output="APT $" />
  </special_format>
</second_unit>
</street_address>
</address_line>
<address_line>
  <po_box>
    <format form="PO BOX 0*" effective="7-8" />
    <format form="P.O. BOX 0*" effective="9-10" />
    <format form="PO 0*" effective="3-4" />
    <format form="P.O. 0*" effective="5-6" />
    <format form="POBOX 0*" effective="6-7" />
  </po_box>
</address_line>
<address_line>
  <city optional="no" />
  <region optional="no" order="1" />
  <postal_code>
    <format form="00000" effective="0-4" />
    <format form="00000-0000" effective="0-4" addon_effective="6-9" />
    <format form="00000 0000" effective="0-4" addon_effective="6-9" />
  </postal_code>
</address_line>
</address_format>

```

11.5.6.1 ADDRESS_FORMAT_STRING Description

The ADDRESS_FORMAT_STRING column of the GC_PARSER_PROFILEAFS table describes the format of address fields and their positioning in valid postal addresses. The address format string is organized by address lines, because postal addresses are typically written in multiple address lines.

The address parser uses the format description defined in the XML address format, combined with the keyword definition for each address field defined in the GC_PARSER_PROFILES table, to parse the input address and identify individual address fields.

<address_format> Element

The <address_format> element includes the unit_separator and replace_hyphen attributes. The unit_separator attribute is used to separate fields in the stored data. By default it is a comma (unit_separator=", "). The replace_hyphen attribute specifies whether to replace all hyphens in the user's input with a space. By default it is set to true (replace_hyphen="true"), that is, it is expected that all names in the data tables will contain a space instead of a hyphen.

If `replace_hyphen="true"`, administrative-area names in the data tables containing hyphens will not be matched during geocoding if `replace_hyphen="true"`; however, these area names with hyphens can be placed in the `REAL_NAME` column of the `GC_AREA` table to be returned as the administrative-area name in the geocoded result. Road names in the `NAME` column of the `GC_ROAD` table containing hyphens will, however, be matched during geocoding, but the matching performance will be degraded.

<address_line> Elements

Each `<address_line>` element in the XML address format string describes the format of an address line. Each `<address_line>` element can have one or more child elements describing the individual address fields, such as street address, city, state (region or province), and postal code. These address field elements are listed in the order that the address fields appear in valid postal addresses. The `optional` attribute of the address field element is set to "no" if the address field is mandatory. By default, address field elements are optional.

<format> Elements

The format descriptions for house number, special street name, post box, and postal code elements are specified with a single or multiple `<format>` elements. Each `<format>` element specifies a valid layout and range of values for a particular address field. The following example illustrates the format used to define a special street name:

```
<format
  form="1* HWY 0*"
  effective="7-8"
  output="$"
  addon_effective="0-1"
  addon_output="$ HIGHWAY" />
```

The `form` attribute uses a regular expression-like string to describe the format: 1 stands for any alphabetic letter; 0 stands for any numerical digit; 2 stands for any alphabetic letter or any numerical digit; 1* specifies a string consisting of all alphabetic letters; 0* specifies a string consisting of all numerical digits; 2* specifies a string consisting of any combination of numerical digits and alphabetic letters. All other symbols represent themselves.

Any string matching the pattern specified by the `form` attribute is considered to be a valid string for its (parent) address field. A valid string can then be broken down into segments specified by the attributes `effective` and `addon_effective`. The `effective` attribute specifies the more important, primary piece of the address string; the `addon_effective` attribute specifies the secondary piece of the address string.

- The `effective` attribute specifies a substring of the full pattern using the start and end positions for the end descriptor of the `form` attribute. In the preceding example, `effective="7-8"` retrieves the substring (counting from position 0) starting at position 7 and ending at position 8, which is the substring defined by `0*`, at the end of the `form` attribute.
- The `addon_effective` attribute specifies a substring of the full pattern using the start and end positions for the start descriptor of the `form` attribute. In the preceding example, `addon_effective="0-1"` retrieves the substring, (counting from position 0) starting at position 0 and ending at position 1, which is the sub-string defined by `1*`, at the beginning of the `form` attribute.

The `output` and `addon_output` attributes specify the output form of the address string for segments specified by the `effective` and `addon_effective` attributes,

respectively. These output forms are used during address matching. The symbol \$ stands for the matched string, and other symbols represent themselves. In the preceding example:

- In `output="$"`, the \$ stands for the substring that was matched in the effective attribute.
- In `addon_output="$ HIGHWAY"`, the \$ HIGHWAY stands for the substring that was matched in the `addon_effective` attribute, followed by a space, followed by the word *HIGHWAY*.

Using the `<format>` element in the preceding example, with `form="1* HWY 0*"`, the input string `'STATE HWY 580'` will have `effective=580`, `output=580`, `addon_effective=STATE`, and `addon_output=STATE HIGHWAY`.

The `<format>` element may also contain an `<exception>` element. The `<exception>` element specifies a string that has a valid form, but must be excluded from the address field. For example, in a `<house_number>` element with valid numbers `0*1*` (that is, any numeric digits followed by any alphabetic letters), specifying `<exception form="0*TH" />` means that any house number with (or without) numeric digits and ending with "TH" must be excluded.

11.5.7 GC_POI_<suffix> Table

The `GC_POI_<suffix>` table (for example, `GC_POI_US`) stores point of interest (POI) information for the country or group of countries associated with the table name suffix. POIs include features such as airports, monuments, and parks. This table contains one or more rows for each point of interest. (For example, it can contain multiple rows for a POI if the POI is associated with multiple settlements.) The `GC_POI_<suffix>` table contains the columns shown in [Table 11-13](#).

Table 11-13 GC_POI_<suffix> Table

Column Name	Data Type	Description
POI_ID	NUMBER	ID number of the POI. (Required)
POI_NAME	VARCHAR2(64)	Name of the POI. (Required)
LANG_CODE	VARCHAR2(3)	3-letter ISO national language code for the language for the POI name. (Required)
FEATURE_CODE	NUMBER	Feature code for the POI, if the data vendor classifies POIs by category. (Optional)
HOUSE_NUMBER	VARCHAR2(10)	House number of the POI; may contain non-numeric characters. (Required)
STREET_NAME	VARCHAR2(80)	Road name of the POI. (Required)
SETTLEMENT_ID	NUMBER(10)	ID number of the settlement to which the POI belongs. (Required if the POI is associated with a settlement)
MUNICIPALITY_ID	NUMBER(10)	ID number of the municipality to which the POI belongs. (Required if the POI is associated with a municipality)
REGION_ID	NUMBER(10)	ID number of the region to which the POI belongs. (Required if the POI is associated with a region)
SETTLEMENT_NAME	VARCHAR2(64)	Name of the settlement to which the POI belongs. (Required if the POI is associated with a settlement)
MUNICIPALITY_NAME	VARCHAR2(64)	Name of the municipality to which the POI belongs. (Required if the POI is associated with a municipality)

Table 11–13 (Cont.) GC_POI_<suffix> Table

Column Name	Data Type	Description
REGION_NAME	VARCHAR2(64)	Name of the region to which the POI belongs. (Required if the POI is associated with a region)
POSTAL_CODE	VARCHAR2(16)	Postal code of the POI. (Required)
VANITY_CITY	VARCHAR2(35)	Name of the city popularly associated with the POI, if it is different from the actual city containing the POI. For example, the London Heathrow Airport is actually located in a town named Hayes, which is part of greater London, but people tend to associate the airport only with London. In this case, the VANITY_CITY value is London. (Optional)
ROAD_SEGMENT_ID	NUMBER	ID of the road segment on which the POI is located. (Required)
SIDE	VARCHAR2(1)	Side of the street on which the POI is located. Possible values: L (left) or R (right). (Required)
PERCENT	NUMBER	Percentage value at which the POI is located on the road. It is computed by dividing the distance from the street segment start point to the POI by the length of the street segment. (Required)
TELEPHONE_NUMBER	VARCHAR2(20)	Telephone number of the POI. (Optional)
LOC_LONG	NUMBER	Longitude coordinate value of the POI. (Required)
LOC_LAT	NUMBER	Latitude coordinate value of the POI. (Required)
COUNTRY_CODE_2	VARCHAR2(2)	2- letter ISO country code of the country to which the POI belongs. (Required)
PARTITION_ID	NUMBER	Partition key used for partitioning geocoder data by geographic boundaries. If the data is not partitioned, set the value to 1. (Required)

11.5.8 GC_POSTAL_CODE_<suffix> Table

The GC_POSTAL_CODE_<suffix> table (for example, GC_POSTAL_CODE_US) stores postal code information for the country or group of countries associated with the table-name suffix, if postal codes are used in the address format. This table contains one or more rows for each postal code; it may contain multiple rows for a postal code when the postal code is associated with multiple settlements. The GC_POSTAL_CODE_<suffix> table contains the columns shown in [Table 11–14](#).

Table 11–14 GC_POSTAL_CODE_<suffix> Table

Column Name	Data Type	Description
POSTAL_CODE	VARCHAR2(16)	Postal code for the postal code area. (Required)
SETTLEMENT_NAME	VARCHAR2(64)	Name of the settlement to which the postal code belongs. (Required if the postal code is associated with a settlement)
MUNICIPALITY_NAME	VARCHAR2(64)	Name of the municipality to which the postal code belongs. (Required if the postal code is associated with a municipality)
REGION_NAME	VARCHAR2(64)	Name of the region to which the postal code belongs. (Required if the postal code is associated with a region)

Table 11–14 (Cont.) GC_POSTAL_CODE_<suffix> Table

Column Name	Data Type	Description
LANG_CODE	VARCHAR2(3)	3-letter ISO national language code for the language associated with the area. (Required)
SETTLEMENT_ID	NUMBER(10)	ID number of the settlement to which the postal code belongs. (Required if the postal code is associated with a settlement)
MUNICIPALITY_ID	NUMBER(10)	ID number of the municipality to which the postal code belongs. (Required if the postal code is associated with a municipality)
REGION_ID	NUMBER(10)	ID number of the region to which the postal code belongs. (Required if the postal code is associated with a region)
CENTER_LONG	NUMBER	Longitude value of the center of the postal-code area. The center (longitude, latitude) value is set to the start- or end-point of the closest road segment to the center, depending on which point is closer. Oracle recommends that the CENTER_LONG and CENTER_LAT values be correctly set. If these values are not set, the longitude, latitude values of the geocoded result for an area will be (0,0). (Optional)
CENTER_LAT	NUMBER	Latitude value of the center of the area. (See the explanation for the CENTER_LONG column.) (Optional)
ROAD_SEGMENT_ID	NUMBER(10)	ID of the road segment to which the area center is set. This value must be set correctly if the geocoder is intended to work with the Oracle Spatial routing engine (described in Chapter 13); otherwise, it can be set to any nonzero value, but it cannot be null. (Required)
COUNTRY_CODE_2	VARCHAR2(2)	2- letter ISO country code of the country to which the area belongs. (Required)
PARTITION_ID	NUMBER	Partition key used for partitioning geocoder data by geographic boundaries. If the data is not partitioned, set the value to 1. (Required)
NUM_STREETS	NUMBER	The number of streets inside this postal code area. (Optional)

11.5.9 GC_ROAD_<suffix> Table

The GC_ROAD_<suffix> table (for example, GC_ROAD_US) stores road information for the country associated with the table name suffix. A road is a collection of road segments with the same name in the same settlement area; a road segment is defined in [Section 11.5.10](#). The GC_ROAD_<suffix> table contains one or more rows for each road. (For example, it can contain multiple rows for a road if the road is associated with multiple settlements.) The GC_ROAD_<suffix> table contains the columns shown in [Table 11–15](#).

Table 11–15 GC_ROAD_<suffix> Table

Column Name	Data Type	Description
ROAD_ID	NUMBER	ID number of the road. (Required)
SETTLEMENT_ID	NUMBER(10)	ID number of the settlement to which the road belongs. (Required if the road is associated with a settlement)

Table 11–15 (Cont.) GC_ROAD_<suffix> Table

Column Name	Data Type	Description
MUNICIPALITY_ID	NUMBER(10)	ID number of the municipality to which the road belongs. (Required if the road is associated with a municipality)
PARENT_AREA_ID	NUMBER(10)	ID number of the parent area of the municipality to which the road belongs. (Required if the road is associated with a parent area)
LANG_CODE	VARCHAR2(3)	3-letter ISO national language code for the language for the road name. (Required)
NAME	VARCHAR2(64)	Name of the road, including the type (if any), the prefix (if any), and the suffix (if any). For example, <i>N Main St</i> as NAME. (Required)
BASE_NAME	VARCHAR2(64)	Name of the road, excluding the type (if any), the prefix (if any), and the suffix (if any). For example, <i>N Main St</i> as NAME, with <i>Main</i> as BASE_NAME. (Required)
PREFIX	VARCHAR2(32)	Prefix of the road name. For example, <i>N Main St</i> as NAME, with <i>N</i> as PREFIX. (Required if the road name has a prefix)
SUFFIX	VARCHAR2(32)	Suffix of the road name. For example, <i>Main St NW</i> as NAME, with <i>NW</i> as SUFFIX. (Required if the road name has a suffix)
STYPE_BEFORE	VARCHAR2(32)	Street type that precedes the base name. For example, <i>Avenue Victor Hugo</i> as NAME, with <i>Avenue</i> as STYPE_BEFORE and <i>Victor Hugo</i> as BASE_NAME. (Required if the road type precedes the base name)
STYPE_AFTER	VARCHAR2(32)	Street type that follows the base name. For example, <i>Main St</i> as NAME, with <i>St</i> as STYPE_AFTER and <i>Main</i> as BASE_NAME. (Required if the road type follows the base name)
STYPE_ATTACHED	VARCHAR2(1)	Contains <i>T</i> if the street type is in the same word with the street name; contains <i>F</i> if the street type is a separate word from the street name. For example, in a German street address of <i>123 Beethovenstrass</i> , the street type is <i>strass</i> , and it is in the same word with the street name, which is <i>Beethoven</i> . (Required)
START_HN	NUMBER(5)	The lowest house number on the road. It is returned when a specified house number is lower than this value.
CENTER_HN	NUMBER(5)	Leading numerical part of the center house number. The center house number is the left side house number at the start point of the center road segment, which is located in the center of the whole road. (See the explanation of house numbers after Table 11–16 in Section 11.5.10 .) It is returned when no house number is specified in an input address. (Required)
END_HN	NUMBER(5)	The highest house number on the road. It is returned when a specified house number is higher than this value.
START_HN_SIDE	VARCHAR2(1)	Side of the road of the lowest house number: <i>L</i> for left or <i>R</i> for right.

Table 11–15 (Cont.) GC_ROAD_<suffix> Table

Column Name	Data Type	Description
CENTER_HN_SIDE	VARCHAR2(1)	Side of the road of the center house number: L for left or R for right. The center house number is the left side house number at the start point of the center road segment, which is located in the center of the whole road. (See the explanation of house numbers after Table 11–16 in Section 11.5.10 .) (Required if there are houses on the road)
END_HN_SIDE	VARCHAR2(1)	Side of the road of the highest house number: L for left or R for right.
START_LONG	NUMBER	Longitude value of the lowest house number.
START_LAT	NUMBER	Latitude value of the lowest house number.
CENTER_LONG	NUMBER	Longitude value of the center house number. The center house number is the left side house number at the start point of the center road segment, which is located in the center of the whole road. (See the explanation of house numbers after Table 11–16 in Section 11.5.10 .) (Required)
CENTER_LAT	NUMBER	Latitude value of the center house number. (See also the explanation of the CENTER_LONG column.) (Required)
END_LONG	NUMBER	Longitude value of the highest house number.
END_LAT	NUMBER	Latitude value of the highest house number.
START_ROAD_SEG_ID	NUMBER(5)	ID number of the road segment at the start of the road.
CENTER_ROAD_SEG_ID	NUMBER(5)	ID number of the road segment at the center point of the road. (Required)
END_ROAD_SEG_ID	NUMBER(5)	ID number of the road segment at the end of the road.
POSTAL_CODE	VARCHAR2(16)	Postal code for the road. (Required)
COUNTRY_CODE_2	VARCHAR2(2)	2-letter ISO country code of the country to which the road belongs. (Required)
PARTITION_ID	NUMBER	Partition key used for partitioning geocoder data by geographic boundaries. If the data is not partitioned, set the value to 1. (Required)
CENTER_HN2	VARCHAR2(10)	The second part of the center house number. (See the explanation of house numbers after Table 11–16 in Section 11.5.10 .) (Required)

11.5.10 GC_ROAD_SEGMENT_<suffix> Table

The GC_ROAD_SEGMENT_<suffix> table (for example, GC_ROAD_SEGMENT_US) stores road segment information for the country associated with the table name suffix. A road segment is the portion of a road between two continuous intersections along the road; an intersection occurs when roads meet or cross each other. A road segment can also be the portion of a road between the start (or end) of the road and its closest intersection along the road, or it can be the entire length of a road if there are no intersections along the road. The GC_ROAD_SEGMENT_<suffix> table contains one row for each road segment, and it contains the columns shown in [Table 11–16](#).

Table 11–16 GC_ROAD_SEGMENT_<suffix> Table

Column Name	Data Type	Description
ROAD_SEGMENT_ID	NUMBER	ID number of the road segment. (Required)
ROAD_ID	NUMBER	ID number of the road containing this road segment. (Required)
L_ADDR_FORMAT	VARCHAR2(1)	Left side address format. Specify N if there are one or more house numbers on the left side of the road segment; leave null if there is no house number on the left side of the road segment. (Required)
R_ADDR_FORMAT	VARCHAR2(1)	Right side address format. Specify N if there are one or more house numbers on the right side of the road segment; leave null if there is no house number on the right side of the road segment. (Required)
L_ADDR_SCHEME	VARCHAR2(1)	Numbering scheme for house numbers on the left side of the road segment: O (all odd numbers), E (all even numbers), or M (mixture of odd and even numbers). (Required)
R_ADDR_SCHEME	VARCHAR2(1)	Numbering scheme for house numbers on the right side of the road segment: O (all odd numbers), E (all even numbers), or M (mixture of odd and even numbers). (Required)
START_HN	NUMBER(5)	The lowest house number on this road segment. (Required)
END_HN	NUMBER(5)	The highest house number on this road segment. (Required)
L_START_HN	NUMBER(5)	The leading numerical part of the left side starting house number. (See the explanation of house numbers after this table.) (Required)
L_END_HN	NUMBER(5)	The leading numerical part of the left side ending house number. (See the explanation of house numbers after this table.) (Required)
R_START_HN	NUMBER(5)	The leading numerical part of the right side starting house number. (See the explanation of house numbers after this table.) (Required)
R_END_HN	NUMBER(5)	The leading numerical part of the right side ending house number. (See the explanation of house numbers after this table.) (Required)
POSTAL_CODE	VARCHAR2(16)	Postal code for the road segment. If the left side and right side of the road segment belong to two different postal codes, create two rows for the road segment with identical values in all columns except for POSTAL_CODE. (Required)
GEOMETRY	SDO_GEOMETRY	Spatial geometry object representing the road segment. (Required)
COUNTRY_CODE_2	VARCHAR2(2)	2- letter ISO country code of the country to which the road segment belongs. (Required)
PARTITION_ID	NUMBER	Partition key used for partitioning geocoder data by geographic boundaries. If the data is not partitioned, set the value to 1. (Required)

Table 11–16 (Cont.) GC_ROAD_SEGMENT_<suffix> Table

Column Name	Data Type	Description
L_START_HN2	VARCHAR2(10)	The second part of the left side starting house number. (See the explanation of house numbers after this table.) (Required if the left side starting house number has a second part)
L_END_HN2	VARCHAR2(10)	The second part of the left side ending house number. (See the explanation of house numbers after this table.) (Required if the left side ending house number has a second part)
R_START_HN2	VARCHAR2(10)	The second part of the right side starting house number. (See the explanation of house numbers after this table.) (Required if the right side starting house number has a second part)
R_END_HN2	VARCHAR2(10)	The second part of the right side ending house number. (See the explanation of house numbers after this table.) (Required if the right side ending house number has a second part)

A house number is a descriptive part of an address that helps identify the location of a establishment along a road segment. A house number is divided into two parts: the leading numerical part and the second part, which is the rest of the house number. The leading numerical part is the numerical part of the house number that starts from the beginning of the complete house number string and ends just before the first non-numeric character (if present). If the house number contains non-numeric characters, the second part of the house number is the portion from the first non-numeric character through the last character of the string. For example, if the house number is 123, the leading numerical part is 123 and the second part is null; however, if the house number is 123A23, the leading numerical part is 123 and the second part is A23.

The starting house number is the house number at the start point of a road segment; the start point of the road segment is the first shape point of the road segment geometry. The ending house number is the house number at the end point of a road segment; the end point of the road segment is the last shape point of the road segment geometry. The left and right side starting house numbers do not need to be lower than the left and right side ending house numbers. The house number attributes in the data tables follow these conventions in locating establishments along road segments.

11.5.11 Indexes on Tables for Geocoding

To use the vendor-supplied tables for geocoding, indexes must be created on many of the tables, and the names of these indexes must follow certain requirements.

[Example 11–5](#) lists the format of CREATE INDEX statements that create the required indexes. In each statement, you must use the index name, table name, column names, and (if multiple columns are indexed) sequence of column names as shown in [Example 11–5](#), except that you must replace all occurrences of <suffix> with the appropriate string (for example, US for the United States). Note that the first index in the example is a spatial index. Optionally, you can also include other valid keywords and clauses in the CREATE INDEX statements.

Example 11–5 Required Indexes on Tables for Geocoding

```
CREATE INDEX idx_<suffix>_road_geom ON gc_road_segment_<suffix> (geometry) INDEXTYPE IS
mdsys.spatial_index;
```

```

CREATE INDEX idx_<suffix>_road_seg_rid ON gc_road_segment_<suffix> (road_id, start_hn, end_hn);
CREATE INDEX idx_<suffix>_road_id ON gc_road_<suffix> (road_id);
CREATE INDEX idx_<suffix>_road_setbn ON gc_road_<suffix> (settlement_id, base_name);
CREATE INDEX idx_<suffix>_road_munbn ON gc_road_<suffix> (municipality_id, base_name);
CREATE INDEX idx_<suffix>_road_parbn ON gc_road_<suffix> (parent_area_id, country_code_2, base_
name);
CREATE INDEX idx_<suffix>_road_setbnsd ON gc_road_<suffix> (settlement_id, soundex(base_name));
CREATE INDEX idx_<suffix>_road_munbnsd ON gc_road_<suffix> (municipality_id, soundex(base_name));
CREATE INDEX idx_<suffix>_road_parbnsd ON gc_road_<suffix> (parent_area_id, country_code_2,
soundex(base_name));
CREATE INDEX idx_<suffix>_inters ON gc_intersection_<suffix> (country_code_2, road_id_1, road_id_
2);
CREATE INDEX idx_<suffix>_area_name_id ON gc_area_<suffix> (country_code_2, area_name, admin_
level);
CREATE INDEX idx_<suffix>_area_id_name ON gc_area_<suffix> (area_id, area_name, country_code_2);
CREATE INDEX idx_<suffix>_poi_name ON gc_poi_<suffix> (country_code_2, name);
CREATE INDEX idx_<suffix>_poi_setnm ON gc_poi_<suffix> (country_code_2, settlement_id, name);
CREATE INDEX idx_<suffix>_poi_munnm ON gc_poi_<suffix> (country_code_2, municipality_id, name);
CREATE INDEX idx_<suffix>_poi_regnm ON gc_poi_<suffix> (country_code_2, region_id, name);
CREATE INDEX idx_<suffix>_postcode ON gc_postal_code_<suffix> (country_code_2, postal_code);
CREATE INDEX idx_<suffix>_addrpt_addr ON gc_address_point_<suffix> (road_segment_id, road_id,
house_number, side);

```

11.6 Installing the Profile Tables

The Oracle Geocoder profile tables are typically supplied by a data provider. Use the data provider's profile tables for geocoding whenever they are available. For users building their own geocoder schema, Oracle provides sample GC_COUNTRY_PROFILE, GC_PARSER_PROFILES, and GC_PARSER_PROFILEAFS tables; however, you should install these Oracle-supplied profile tables *only* if profile tables are *not* supplied with the data tables.

The Oracle-supplied tables contain parser profiles for a limited number of countries. If profiles for your country or group of countries of interest are not included, you will need to manually add them; and for a quick start, you can copy the parser profiles of a country with a similar address format to your country of interest, and edit these profiles where necessary. If your parser profiles of interest are included in the Oracle-supplied tables, you can use them directly or update them if necessary. No sample country profiles are provided, so you will need to add your own

To install and query the Oracle-supplied profile tables, perform the following steps:

1. Log on to your database as the geocoder user. The geocoder user is the user under whose schema the geocoder schema will be loaded.
2. Create the GC_COUNTRY_PROFILE, GC_PARSER_PROFILES, and GC_PARSER_PROFILEAFS tables by executing the [SDO_GCDR.CREATE_PROFILE_TABLES](#) procedure:

```
SQL> EXECUTE SDO_GCDR.CREATE_PROFILE_TABLES;
```

3. Populate the GC_PARSER_PROFILES and GC_PARSER_PROFILEAFS tables by running the `sdogcprs.sql` script in the `$ORACLE_HOME/md/admin/` directory. For example:

```
SQL> @$ORACLE_HOME/md/admin/sdogcprs.sql
```

4. Query the profile tables to determine if parser profiles for your country of interest are supplied, by checking if its country code is included in the output of the following statements:

```
SQL> SELECT DISTINCT(country_code) FROM gc_parser_profiles ORDER BY country_
code;
SQL> SELECT DISTINCT(country_code) FROM gc_parser_profileafs ORDER BY country_
code;
```

11.7 Using the Geocoding Service (XML API)

In addition to the SQL API, Oracle Spatial also provides an XML API for a geocoding service that enables you to geocode addresses. A Java geocoder application engine performs international address standardization, geocoding, and POI matching, by querying geocoder data stored in the Oracle database. The support for unparsed addresses adds flexibility and convenience to customer applications.

This geocoding service is implemented as a Java 2 Enterprise Edition (J2EE) Web application that you can deploy in a WebLogic Server, Oracle Application Server, or standalone Oracle Application Server Containers for J2EE (OC4J) environment.

- If the geocoding service is deployed in a standalone OC4J, the user name is `oc4jadmin` and the password is the administrator password you specified when you installed the OC4J instance.
- If the geocoding service is deployed in a full Oracle Application Server, you must have created a security user in the OC4J instance where the geocoding service is running, and mapped the security user to the geocoding service's built-in security role `GC_ADMIN_ROLE`. After you have completed these tasks through Enterprise Manager, you can then use that security user's name and password to log in as the geocoding service administrator.

Figure 11–1 shows the basic flow of action with the geocoding service: a client locates a remote geocoding service instance, sends a geocoding request, and processes the response returned by the geocoding service instance.

Figure 11–1 Basic Flow of Action with the Spatial Geocoding Service

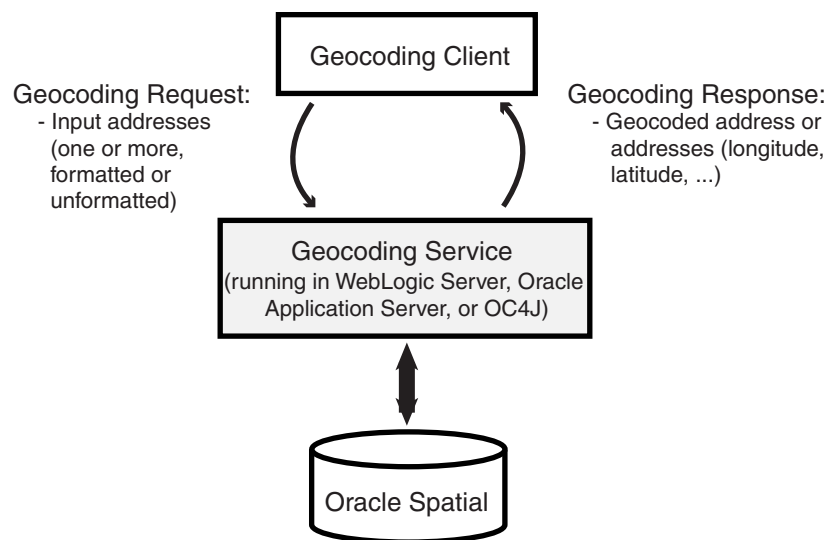

As shown in Figure 11–1:

1. The client sends an XML geocoding request, containing one or more input addresses to be geocoded, to the geocoding service using the HTTP protocol.

2. The geocoding service parses the input request and looks up the input address in the database.
3. The geocoding service sends the geocoded result in XML format to the client using the HTTP protocol.

After you load the geocoder schema into the database, you must configure the J2EE geocoder before it can be used, as explained in [Section 11.7.1](#)

11.7.1 Deploying and Configuring the J2EE Geocoder

The J2EE geocoder processes geocoding requests and generates responses. To enable this geocoding service, the geocoder.ear file (in `$ORACLE_HOME/md/jlib`) must be deployed using the Oracle WebLogic Server, Oracle Application Server (OracleAS), or a standalone installation of Oracle Application Server Containers for J2EE (OC4J). To deploy and configure the geocoding service, follow these steps.

1. Deploy the geocoder using Oracle WebLogic Server, Oracle Application Server, or OC4J:
 - **Using Oracle WebLogic Server:** Unpack the geocoder.ear file in your `$ORACLE_HOME/md/jlib` directory. Rename the geocoder.ear file and unpack its contents into a directory called `./geocoder.ear`. Rename the web.war file now found under the `$geocoder.ear/` directory and unpack its contents into a subdirectory called `./web.war`. Your directory structure should therefore be `$geocoder.ear/web.war/`.

After unpacking the geocoder.ear and web.war files, copy the `xmlparserv2.jar` file in your `$ORACLE_HOME/LIB/` directory into the `$geocoder.ear/web.war/WEB-INF/lib/` directory.

To deploy the `geocoder.ear` file, log on to the WLS console (for example, `http://<hostname>:7001/console`); and from Deployments, install the `geocoder.ear` file, accepting the name `geocoder` for the deployment and choosing the option to make the deployment accessible from a specified location.
 - **Using Oracle Application Server or OC4J:** Deploy the `geocoder.ear` file in your `$ORACLE_HOME/md/jlib` directory using the OracleAS or the standalone OC4J Application Server Control (for example, `http://<hostname>:8888/em`). You can deploy the `geocoder.ear` file in an existing OC4J instance, or you can create a new OC4J instance for the geocoder. In either case, enter `geocoder` for the Application Name during deployment.
2. Launch the Oracle Geocoder welcome page in a Web browser using the URL `http://<hostname>:<port>/geocoder`. On the welcome page, select the Administration link and enter the administrator (`weblogic` or `oc4jadmin`) user name and password.

Note: If you are using WebLogic Server and if you are *not* using the default WebLogic administrator user name, you will need to edit the `weblogic.xml` file located in the `$geocoder.ear/web.war/WEB-INF/` directory. Replace `<principal-name>weblogic</principal-name>` with your WebLogic Server administrator user name, for example, `<principal-name>my_weblogic_admin</principal-name>`.

3. Modify the geocoder configuration file (`geocodercfg.xml`). Uncomment at least one `<geocoder>` element, and change the `<database>` element attributes of that `<geocoder>` element to reflect the configuration of your database. For information about this file, see [Section 11.7.1.1](#).

4. Save the changes to the file, and restart the geocoder.

If the welcome page is not displayed, ensure that the newly deployed geocoding service was successfully started. It is assumed that you are running WebLogic Server 10.3.1.0 or later with an Oracle Database Release 11.2 or later `geocoder.ear` file; or that you are running Oracle AS or OC4J 10.1.3 or later with an Oracle 11g or later `geocoder.ear` file.

5. Test the database connection by going to the welcome page at URL `http://<hostname>:<port>/geocoder` and running the international postal address parsing/geocoding demo and the XML geocoding request page. (These demos require geocoder data for the United States.)

Examples are available to demonstrate various capabilities of the geocoding service. Using the examples is the best way to learn the XML API, which is described in [Section 11.7.2](#).

11.7.1.1 Configuring the `geocodercfg.xml` File

You will need to edit the `<database>` element in the default `geocodercfg.xml` file that is included with Spatial, to specify the database and schema where the geocoding data is loaded.

In this file, each `<geocoder>` element defines the geocoder for the database in which the geocoder schema resides. The `<database>` element defines the database connection for the geocoder. In Oracle 11g or later, there are two ways to define a database connection: by providing the JDBC database connection parameters, or by providing the JNDI name (`container_ds`) of a predefined container data source.

[Example 11-6](#) illustrates two different ways in which a `<database>` element can be defined. The first definition specifies a JDBC connection; the second definition uses the JNDI name of a predefined container data source.

Example 11-6 `<database>` Element Definitions

```
<database name="gcdatabase"
  host="gisserver.us.oracle.com"
  port="1521"
  sid="orcl"
  mode="thin"
  user="geocoder_us"
  password="geocoder_us"
  load_db_parser_profiles="true" />

<database container_ds="jdbc/gc_europe"
  load_db_parser_profiles="true" />
```

The attributes of the `<database>` element are as follows

- `name` is a descriptive name for the database connection; it is not used to connect to the database.
- `host`, `port`, and `sid` identify the database.
- `mode` identifies the type of JDBC driver to use for the connection.

- `user` and `password` are the user name and password for the database user under whose schema the geocoding data is stored.
- `load_db_parser_profiles` specifies whether to load the address parser profiles from the specified database connection. If `true`, the address parser-profiles are loaded from the geocoder schema; otherwise, the parser profiles are loaded from the application at `../applications/geocoder/web/WEB-INF/parser_profiles/<country-name>.ppr` (for example, `usa.ppr`). Before Oracle 11g, parser profiles were loaded from the application only. This parameter should be set to `true`.
- `container_ds` specifies the JNDI name for a predefined data source.

11.7.2 Geocoding Request XML Schema Definition and Example

For a geocoding request (HTTP GET or POST method), it is assumed the request has a parameter named `xml_request` whose value is a string containing the XML document for the request. The input XML document describes the input addresses that need to be geocoded. One XML request can contain one or more input addresses. Several internationalized address formats are available for describing the input addresses. (The input XML API also supports reverse geocoding, that is, a longitude/latitude point to a street address.)

The XML schema definition (XSD) for a geocoding request is as follows:

```
<?xml version="1.0" encoding="UTF-8"?>
<!-- Schema for an XML geocoding request that takes one or more input_locations
and supports reverse geocoding using the input_location's attributes -->
<xsd:schema xmlns:xsd="http://www.w3.org/2001/XMLSchema"
elementFormDefault="qualified">
  <xsd:complexType name="address_lineType">
    <xsd:attribute name="value" type="xsd:string" use="required"/>
  </xsd:complexType>
  <xsd:complexType name="address_listType">
    <xsd:sequence>
      <xsd:element name="input_location" type="input_locationType"
maxOccurs="unbounded"/>
    </xsd:sequence>
  </xsd:complexType>
  <xsd:complexType name="gdf_formType">
    <xsd:attribute name="name" type="xsd:string"/>
    <xsd:attribute name="street" type="xsd:string"/>
    <xsd:attribute name="intersecting_street" type="xsd:string"/>
    <xsd:attribute name="builtup_area" type="xsd:string"/>
    <xsd:attribute name="order8_area" type="xsd:string"/>
    <xsd:attribute name="order2_area" type="xsd:string"/>
    <xsd:attribute name="order1_area" type="xsd:string"/>
    <xsd:attribute name="country" type="xsd:string"/>
    <xsd:attribute name="postal_code" type="xsd:string"/>
    <xsd:attribute name="postal_addon_code" type="xsd:string"/>
  </xsd:complexType>
  <xsd:complexType name="gen_formType">
    <xsd:attribute name="name" type="xsd:string"/>
    <xsd:attribute name="street" type="xsd:string"/>
    <xsd:attribute name="intersecting_street" type="xsd:string"/>
    <xsd:attribute name="sub_area" type="xsd:string"/>
    <xsd:attribute name="city" type="xsd:string"/>
    <xsd:attribute name="region" type="xsd:string"/>
    <xsd:attribute name="country" type="xsd:string"/>
  </xsd:complexType>
</xsd:schema>
```

```

    <xsd:attribute name="postal_code" type="xsd:string"/>
    <xsd:attribute name="postal_addon_code" type="xsd:string"/>
  </xsd:complexType>
</xsd:element name="geocode_request">
  <xsd:complexType>
    <xsd:sequence>
      <xsd:element name="address_list" type="address_listType"/>
    </xsd:sequence>
    <xsd:attribute name="vendor" type="xsd:string"/>
  </xsd:complexType>
</xsd:element>
<xsd:complexType name="input_addressType">
  <xsd:choice>
    <xsd:element name="us_form1" type="us_form1Type"/>
    <xsd:element name="us_form2" type="us_form2Type"/>
    <xsd:element name="gdf_form" type="gdf_formType"/>
    <xsd:element name="gen_form" type="gen_formType"/>
    <xsd:element name="unformatted" type="unformattedType"/>
  </xsd:choice>
  <xsd:attribute name="match_mode" default="relax_postal_code">
    <xsd:simpleType>
      <xsd:restriction base="xsd:NMTOKEN">
        <xsd:enumeration value="exact"/>
        <xsd:enumeration value="relax_street_type"/>
        <xsd:enumeration value="relax_poi_name"/>
        <xsd:enumeration value="relax_house_number"/>
        <xsd:enumeration value="relax_base_name"/>
        <xsd:enumeration value="relax_postal_code"/>
        <xsd:enumeration value="relax_builtup_area"/>
        <xsd:enumeration value="relax_all"/>
        <xsd:enumeration value="DEFAULT"/>
      </xsd:restriction>
    </xsd:simpleType>
  </xsd:attribute>
</xsd:complexType>
<xsd:complexType name="input_locationType">
  <xsd:sequence>
    <xsd:element name="input_address" type="input_addressType"
      minOccurs="0"/>
  </xsd:sequence>
  <xsd:attribute name="id" type="xsd:string"/>
  <xsd:attribute name="country" type="xsd:string"/>
  <xsd:attribute name="longitude" type="xsd:string"/>
  <xsd:attribute name="latitude" type="xsd:string"/>
  <xsd:attribute name="x" type="xsd:string"/>
  <xsd:attribute name="y" type="xsd:string"/>
  <xsd:attribute name="srid" type="xsd:string"/>
  <xsd:attribute name="multimatch_number" type="xsd:string" default="1000"/>
</xsd:complexType>
<xsd:complexType name="unformattedType">
  <xsd:sequence>
    <xsd:element name="address_line" type="address_lineType"
      maxOccurs="unbounded"/>
  </xsd:sequence>
  <xsd:attribute name="country" type="xsd:string"/>
</xsd:complexType>
<xsd:complexType name="us_form1Type">
  <xsd:attribute name="name" type="xsd:string"/>
  <xsd:attribute name="street" type="xsd:string"/>
  <xsd:attribute name="intersecting_street" type="xsd:string"/>

```

```

    <xsd:attribute name="lastline" type="xsd:string"/>
  </xsd:complexType>
  <xsd:complexType name="us_form2Type">
    <xsd:attribute name="name" type="xsd:string"/>
    <xsd:attribute name="street" type="xsd:string"/>
    <xsd:attribute name="intersecting_street" type="xsd:string"/>
    <xsd:attribute name="city" type="xsd:string"/>
    <xsd:attribute name="state" type="xsd:string"/>
    <xsd:attribute name="zip_code" type="xsd:string"/>
  </xsd:complexType>
</xsd:schema>

```

[Example 11-7](#) is a request to geocode several three addresses (representing two different actual physical addresses), using different address formats and an unformatted address.

Example 11-7 Geocoding Request (XML API)

```

<?xml version="1.0" encoding="UTF-8"?>
<geocode_request xmlns:xsi="http://www.w3.org/2001/XMLSchema-instance"
xsi:noNamespaceSchemaLocation="../geocode_request.xsd">
  <address_list>
    <input_location id="1">
      <input_address>
        <us_form2 name="Oracle" street="500 Oracle Parkway" city="Redwood City"
state="CA" zip_code="94021"/>
      </input_address>
    </input_location>
    <input_location id="2">
      <input_address>
        <gdf_form street="1 Oracle Drive" builtup_area="Nashua" order1_area="NH"
postal_code="03062" country="US"/>
      </input_address>
    </input_location>
    <input_location id="3">
      <input_address>
        <gen_form street="1 Oracle Drive" city="Nashua" region="NH" postal_code="03062" country="US"/>
      </input_address>
    </input_location>
    <input_location id="4">
      <input_address>
        <unformatted country="UNITED STATES">
          <address_line value="Oracle NEDC"/>
          <address_line value="1 Oracle drive "/>
          <address_line value="Nashua "/>
          <address_line value="NH"/>
        </unformatted>
      </input_address>
    </input_location>
  </address_list>
</geocode_request>

```

11.7.3 Geocoding Response XML Schema Definition and Example

A geocoding response contains one or more standardized addresses including longitude/latitude points, the matching code, and possibly multiple match and no match indication and an error message.

The XML schema definition (XSD) for a geocoding response is as follows:

```

<?xml version="1.0" encoding="UTF-8"?>
<!-- Schema for an XML geocoding response -->
<xsd:schema xmlns:xsd="http://www.w3.org/2001/XMLSchema"
elementFormDefault="qualified">
  <xsd:complexType name="geocodeType">
    <xsd:sequence>
      <xsd:element name="match" type="matchType" minOccurs="0"
maxOccurs="unbounded"/>
    </xsd:sequence>
    <xsd:attribute name="id" type="xsd:string" use="required"/>
    <xsd:attribute name="match_count" type="xsd:string"/>
  </xsd:complexType>
  <xsd:element name="geocode_response">
    <xsd:complexType>
      <xsd:sequence>
        <xsd:element name="geocode" type="geocodeType" maxOccurs="unbounded"/>
      </xsd:sequence>
    </xsd:complexType>
  </xsd:element>
  <xsd:complexType name="matchType">
    <xsd:sequence>
      <xsd:element name="output_address" type="output_addressType"/>
    </xsd:sequence>
    <xsd:attribute name="sequence" type="xsd:string" use="required"/>
    <xsd:attribute name="longitude" type="xsd:string" use="required"/>
    <xsd:attribute name="latitude" type="xsd:string" use="required"/>
    <xsd:attribute name="match_code" use="required">
      <xsd:simpleType>
        <xsd:restriction base="xsd:NMTOKEN">
          <xsd:enumeration value="0"/>
          <xsd:enumeration value="1"/>
          <xsd:enumeration value="2"/>
          <xsd:enumeration value="3"/>
          <xsd:enumeration value="4"/>
          <xsd:enumeration value="10"/>
          <xsd:enumeration value="11"/>
        </xsd:restriction>
      </xsd:simpleType>
    </xsd:attribute>
    <xsd:attribute name="error_message" type="xsd:string"/>
  </xsd:complexType>
  <xsd:complexType name="output_addressType">
    <xsd:attribute name="name" type="xsd:string"/>
    <xsd:attribute name="house_number" type="xsd:string"/>
    <xsd:attribute name="street" type="xsd:string"/>
    <xsd:attribute name="builtup_area" type="xsd:string"/>
    <xsd:attribute name="order1_area" type="xsd:string"/>
    <xsd:attribute name="order8_area" type="xsd:string"/>
    <xsd:attribute name="country" type="xsd:string"/>
    <xsd:attribute name="postal_code" type="xsd:string"/>
    <xsd:attribute name="postal_addon_code" type="xsd:string"/>
    <xsd:attribute name="side" type="xsd:string"/>
    <xsd:attribute name="percent" type="xsd:string"/>
    <xsd:attribute name="edge_id" type="xsd:string"/>
  </xsd:complexType>
</xsd:schema>

```

[Example 11–8](#) is the response to the request in [Example 11–7](#) in [Section 11.7.2](#).

Example 11-8 Geocoding Response (XML API)

```

<?xml version="1.0" encoding="UTF-8"?>
<geocode_response xmlns:xsi="http://www.w3.org/2001/XMLSchema-instance"
  xsi:noNamespaceSchemaLocation="../geocode_response.xsd">
  <geocode id="1" match_count="1">
    <match sequence="0"
      longitude="-122.26193971893862" latitude="37.53195483966782"
      match_code="10" error_message="????#ENUT?B281C??">
      <output_address name="" house_number="500" street="ORACLE PKY"
        buildup_area="REDWOOD CITY" order1_area="CA" order8_area=""
        country="US" postal_code="94065" postal_addon_code="" side="L"
        percent="0.33166666666666667" edge_id="28503563"/>
    </match>
  </geocode>
  <geocode id="2" match_count="1">
    <match sequence="0"
      longitude="-71.45937299307225" latitude="42.70784494226865"
      match_code="1" error_message="????#ENUT?B281CP??">
      <output_address name="" house_number="1" street="ORACLE DR"
        buildup_area="NASHUA" order1_area="NH" order8_area=""
        country="US" postal_code="03062" postal_addon_code="" side="L"
        percent="0.01" edge_id="22325991"/>
    </match>
  </geocode>
  <geocode id="3" match_count="1">
    <match sequence="0"
      longitude="-71.45937299307225" latitude="42.70784494226865"
      match_code="1" error_message="????#ENUT?B281CP??">
      <output_address name="" house_number="1" street="ORACLE DR"
        buildup_area="NASHUA" order1_area="NH" order8_area=""
        country="US" postal_code="03062" postal_addon_code="" side="L"
        percent="0.01" edge_id="22325991"/>
    </match>
  </geocode>
  <geocode id="4" match_count="1">
    <match sequence="0"
      longitude="-71.45937299307225" latitude="42.70784494226865"
      match_code="1" error_message="????#ENUT?B281CP??">
      <output_address name="" house_number="1" street="ORACLE DR"
        buildup_area="NASHUA" order1_area="NH" order8_area=""
        country="US" postal_code="03062" postal_addon_code="" side="L"
        percent="0.01" edge_id="22325991"/>
    </match>
  </geocode>
</geocode_response>

```

Business Directory (Yellow Pages) Support

This chapter describes Oracle Spatial support for OpenLS business directory (Yellow Pages, or YP) services. It includes the following major sections:

- [Section 12.1, "Business Directory Concepts"](#)
- [Section 12.2, "Using the Business Directory Capabilities"](#)
- [Section 12.3, "Data Structures for Business Directory Support"](#)

12.1 Business Directory Concepts

Business directory services provide lists of businesses in a given area and matching a specified name or category.

Business directory data comes from third-party providers of such data. These providers probably have different business categories, and even different hierarchical structures. A unifying pattern in the various approaches is that businesses are categorized by subject and location. The location component is well understood; for example, for the United States, either a ZIP code or the combination of a city and state, and optionally a specific address, can be used to determine the location from which to start searching.

The categorization of businesses, on the other hand, is not uniformly implemented. Some providers offer a flat list of categories, user-selected by simple substring matching. Others offer a 3-level or 4-level hierarchical organization of subcategories, often with a fanout (maximum number of child categories at a level) of 20 to 50, and sometimes more than 100. A user might start the hierarchy traversal at the root of the hierarchy (by default). Alternatively, a user might enter a keyword that is matched to an appropriate starting point within the hierarchy. Such keyword matching might go beyond simple substring matching and result in more intelligent choices.

12.2 Using the Business Directory Capabilities

To use the Oracle Spatial business directory capabilities, you must use data provided by a geocoding vendor, and the data must be in the format supported by the Oracle Spatial OpenLS support. For information about getting and loading this data, go to the Spatial page of the Oracle Technology Network (OTN):

<http://www.oracle.com/technology/products/spatial/>

Find the link for business directory (YP) support, and follow the instructions.

To submit users' directory services requests and to return the responses, use the OpenLS Web services API, which is introduced in [Section 14.2](#). For information about directory services requests and responses, with examples, see [Section 14.3](#).

12.3 Data Structures for Business Directory Support

After you acquire the business directory data and invoke the appropriate procedure to load it into the database, the procedure populates the following tables, all owned by the MDSYS schema, which are used for business directory support:

- OPENLS_DIR_BUSINESSES
- OPENLS_DIR_BUSINESS_CHAINS
- OPENLS_DIR_CATEGORIES
- OPENLS_DIR_CATEGORIZATIONS
- OPENLS_DIR_CATEGORY_TYPES
- OPENLS_DIR_SYNONYMS

In some tables, some rows have null values for some columns, because the information does not apply in this instance or because the data provider did not supply a value.

The following sections describe these tables, in alphabetical order by table name.

12.3.1 OPENLS_DIR_BUSINESSES Table

The OPENLS_DIR_BUSINESSES table stores information about each business (that is, each business that has an address). If the business is part of a larger business chain, the CHAIN_ID column is a foreign key to the CHAIN_ID column in the OPENLS_DIR_BUSINESS_CHAINS table (described in [Section 12.3.2](#)).

The OPENLS_DIR_BUSINESSES table contains one row for each business, and it contains the columns shown in [Table 12-1](#).

Table 12-1 OPENLS_DIR_BUSINESSES Table

Column Name	Data Type	Description
BUSINESS_ID	NUMBER	Business ID number. (Required)
BUSINESS_NAME	VARCHAR2(128)	Area name. (Required)
CHAIN_ID	NUMBER	ID number of the business chain (in the OPENLS_DIR_BUSINESS_CHAIN table), if the business is part of a chain.
DESCRIPTION	VARCHAR2(1024)	Description of the business.
PHONE	VARCHAR2(64)	Phone number, in an appropriate format for the location.
COUNTRY	VARCHAR2(64)	Country code or name. (Required)
COUNTRY_SUBDIVISION	VARCHAR2(128)	Subdivision of the country, if applicable.
COUNTRY_SECONDARY_SUBDIVISION	VARCHAR2(128)	Subdivision within COUNTRY_SUBDIVISION, if applicable.
MUNICIPALITY	VARCHAR2(128)	Municipality name.
MUNICIPALITY_SUBDIVISION	VARCHAR2(128)	Subdivision within MUNICIPALITY, if applicable.
POSTAL_CODE	VARCHAR2(32)	Postal code (for example, 5-digit ZIP code in the United States and Canada). (Required)
POSTAL_CODE_EXT	VARCHAR2(32)	Postal code extension (for example, 4-digit extension if the 5-4 ZIP code format is used).

Table 12–1 (Cont.) OPENLS_DIR_BUSINESSES Table

Column Name	Data Type	Description
STREET	VARCHAR2(128)	Street address, including house or unit number. (Required)
INTERSECTING_ STREET	VARCHAR2(128)	Name of the street (if any) that intersects STREET at this address.
BUILDING	VARCHAR2(128)	Name of the building that includes this address.
PARAMETERS	XMLTYPE	XML document with additional information about the business.
GEOM	SDO_GEOMETRY	Point geometry representing the address of the business.

12.3.2 OPENLS_DIR_BUSINESS_CHAINS Table

The OPENLS_DIR_BUSINESS_CHAINS table stores information about each business chain. A business chain is a business that has multiple associated businesses; for example, a restaurant chain has multiple restaurants that have the same name and offer basically the same menu. If the business is part of a business chain, the row for that business in the OPENLS_DIR_BUSINESSES table (described in [Section 12.3.1](#)) contains a CHAIN_ID column value that matches a value in the CHAIN_ID column in the OPENLS_DIR_BUSINESS_CHAINS table.

The OPENLS_DIR_BUSINESS_CHAINS table contains one row for each business chain, and it contains the columns shown in [Table 12–2](#).

Table 12–2 OPENLS_DIR_BUSINESS_CHAINS Table

Column Name	Data Type	Description
CHAIN_ID	NUMBER	Business chain ID number. (Required)
CHAIN_NAME	VARCHAR2(128)	Business chain name.

12.3.3 OPENLS_DIR_CATEGORIES Table

The OPENLS_DIR_CATEGORIES table stores information about each category into which a business can be placed. If the data provider uses a category hierarchy, this table contains rows for categories at all levels of the hierarchy, using the PARENT_ID column to indicate the parent category of a child category. For example, a Restaurants category might be the parent of several child categories, one of which might be Chinese.

The OPENLS_DIR_CATEGORIES table contains one row for each category, and it contains the columns shown in [Table 12–3](#).

Table 12–3 OPENLS_DIR_CATEGORIES Table

Column Name	Data Type	Description
CATEGORY_ID	VARCHAR2(32)	Category ID string. (Required)
CATEGORY_ TYPE_ID	NUMBER	Category type ID number. Must match a value in the CATEGORY_TYPE_ID column of the OPENLS_DIR_CATEGORY_TYPES table (described in Section 12.3.5). (Required)
CATEGORY_ NAME	VARCHAR2(128)	Category name. (Required)

Table 12-3 (Cont.) OPENLS_DIR_CATEGORIES Table

Column Name	Data Type	Description
PARENT_ID	VARCHAR2(32)	CATEGORY_ID value of the parent category, if any, for this category.
PARAMETERS	XMLTYPE	XML document with additional information about the category.

12.3.4 OPENLS_DIR_CATEGORIZATIONS Table

The OPENLS_DIR_CATEGORIZATIONS table stores information about associations of businesses with categories. Each business can be in multiple categories; and the categories for a business can be independent of each other or in a parent-child relationship, or both. For example, a store that sells books and music CDs might be in the categories for Bookstores, Music, and its child category Music Stores, in which case there will be three rows for that business in this table.

The OPENLS_DIR_CATEGORIZATIONS table contains one row for each association of a business with a category, and it contains the columns shown in [Table 12-4](#).

Table 12-4 OPENLS_DIR_CATEGORIZATIONS Table

Column Name	Data Type	Description
BUSINESS_ID	NUMBER	Business ID. Must match a value in the BUSINESS_ID column of the OPENLS_DIR_BUSNESSES table (described in Section 12.3.1). (Required)
CATEGORY_ID	VARCHAR2(32)	Category ID string. The CATEGORY_ID and CATEGORY_TYPE_ID values must match corresponding column values in a single row in the OPENLS_DIR_CATEGORIES table (described in Section 12.3.3). (Required)
CATEGORY_TYPE_ID	NUMBER	Category type ID number. The CATEGORY_ID and CATEGORY_TYPE_ID values must match corresponding column values in a single row in the OPENLS_DIR_CATEGORIES table (described in Section 12.3.3). (Required)
CATEGORIZATION_TYPE	VARCHAR2(8)	EXPLICIT (the default) or IMPLICIT.
USER_SPECIFIC_CATEGORIZATION	VARCHAR2(32)	User-specified categorization, if any.
PARAMETERS	XMLTYPE	XML document with additional information about the association of the business with the category.

12.3.5 OPENLS_DIR_CATEGORY_TYPES Table

The OPENLS_DIR_CATEGORY_TYPES table stores information about category types. This table contains the columns shown in [Table 12-5](#).

Table 12-5 OPENLS_DIR_CATEGORY_TYPES Table

Column Name	Data Type	Description
CATEGORY_TYPE_ID	NUMBER	Category type ID number. (Required)
CATEGORY_TYPE_NAME	VARCHAR2(128)	Name of the category type. (Required)
PARAMETERS	XMLTYPE	XML document with additional information about the category type.

12.3.6 OPENLS_DIR_SYNONYMS Table

The OPENLS_DIR_SYNONYMS table stores information about synonyms for categories. Synonyms can be created to expand the number of terms (strings) associated with a category, so that users get more complete and meaningful results from a search.

The OPENLS_DIR_SYNONYMS table contains one row for each synonym definition, and it contains the columns shown in [Table 12-6](#).

Table 12-6 OPENLS_DIR_SYNONYMS Table

Column Name	Data Type	Description
STANDARD_NAME	VARCHAR2(128)	Standard name of a category, as the user might enter it.
CATEGORY	VARCHAR2(128)	Category name, as it appears in the OPENLS_DIR_CATEGORIES table (described in Section 12.3.3).
AKA	VARCHAR2(128)	.Additional or alternate name for the category. ("AKA" stands for "also known as.")

Routing Engine

The Spatial routing engine enables you to host an XML-based Web service that provides the following features:

- For an individual route request (a start location and an end location): route information (driving distances, estimated driving times, and directions) between the two locations
- For a batch route request (multiple routes, with the same start location but different end locations): route information (driving distance and estimated driving time) for each route

For any request, the start and end locations are identified by addresses, geocoded results, or longitude/latitude coordinates.

A route can be single-address, consisting of the start location and the end location, or multi-address, consisting of the start location, one or more intermediate locations, and the end location.

Multi-address routes are explained in [Section 13.1](#).

The routing engine is implemented as a Java 2 Enterprise Edition (J2EE) Web application that you can deploy in an Oracle Weblogic Server, Oracle Application Server, or standalone Oracle Application Server Containers for J2EE (OC4J) environment.

[Figure 13-1](#) shows the basic flow of action with the routing engine: a client locates a remote routing engine instance, sends a route request, and processes the route response returned by the routing engine instance.

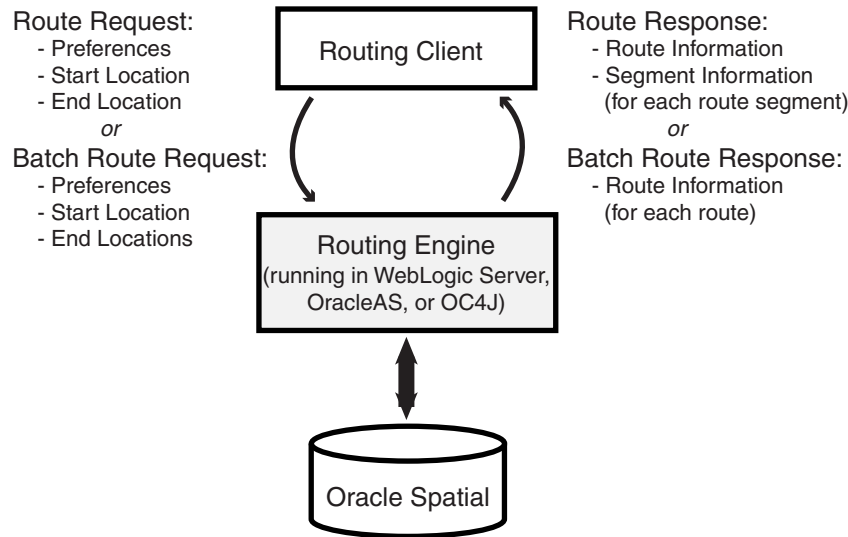
Figure 13–1 Basic Flow of Action with the Spatial Routing Engine

This chapter contains the following major sections:

- [Section 13.1, "Multi-Address Routing"](#)
- [Section 13.2, "Deploying and Configuring the Routing Engine"](#)
- [Section 13.3, "Routing Engine XML API"](#)
- [Section 13.4, "Data Structures Used by the Routing Engine"](#)

13.1 Multi-Address Routing

A multi-address route contains one or more intermediate locations in addition to the start and end locations. A multi-address route thus contains subroutes: each **subroute** covers the path between two locations. A route or subroute contains one or more segments: each **segment** covers the path between two points along the route or subroute.

For example, assume you want to drive from your workplace to customer A, then to customer B, and then to customer C.

- Your *route* has your workplace as the start location, customers A and B as intermediate locations, and customer C as the end location.
- Your route has three *subroutes*: (1) workplace to customer A, (2) customer A to customer B, and (3) customer B to customer C.
- Each subroute probably has multiple *segments* (each one associated with a specific driving direction step).

A multi-address route contains a `<start_location>` element, one or more `<location>` elements, and an `<end_location>` element. Several subroute-related attributes of these elements apply only to multi-address routing, for example, `return_subroutes`, `return_subroute_edge_ids`, and `return_subroute_geometry`. These elements and attributes are explained in [Section 13.3.2](#).

In multi-address routing, the route that is returned has the locations in exactly the order specified in the request. Multi-address routing does not attempt to optimize the

route for time or distance by rearranging the locations; specifically, it does not perform any TSP ("traveling salesperson problem") computations.

13.2 Deploying and Configuring the Routing Engine

To enable the routing engine to process routing requests and to generate responses, you must create a network (Oracle Database network data model network) on top of the routing data, and then deploy the `routesserver.ear` file using Oracle WebLogic Server, Oracle Application Server, or OC4J. This section describes the basic steps.

To create the network, follow these steps:

1. If a network with the routing data already exists, drop it, to ensure that all structures are "clean" in the network to be created. To drop the existing network, execute a statement in the following form:

```
EXECUTE SDO_ROUTER_PARTITION.DELETE_ROUTER_NETWORK('<log_file_name>',
'<network_name>');
```

`<log_file_name>` is the name of the log file that was specified in the call to `SDO_ROUTER_PARTITION.DELETE_ROUTER_NETWORK` to create the network to be dropped.

`<network_name>` is the name of the network to be dropped.

For example:

```
EXECUTE SDO_ROUTER_PARTITION.DELETE_ROUTER_NETWORK('create_sf_net.log', 'ndm_
sf_net');
```

2. Create the network for the routing data by executing a statement in the following form:

```
EXECUTE SDO_ROUTER_PARTITION.CREATE_ROUTER_NETWORK('<log_file_name>',
'<network_name>');
```

`<log_file_name>` is the name of the log file to use for this network.

`<network_name>` is the name of the network to be created.

For example:

```
EXECUTE SDO_ROUTER_PARTITION.CREATE_ROUTER_NETWORK('create_sf_net.log', 'ndm_
sf_net');
```

The log file initially contains messages similar to the following:

```
INFO: creating the Routeserver network: NDM_SF_NET
      creating indexes
      creating views
      generating metadata
```

To deploy and configure the routing engine, follow these steps:

1. Add the following element inside the `<web-site>` element in your `http-web-site.xml` or `default-web-site.xml` file:

```
<web-app application="routesserver"
  name="web"
  load-on-startup="true"
  root="/routesserver"
  max-inactivity-time="no shutdown"
  shared="false" />
```

2. Deploy the routing engine using Oracle WebLogic Server, Oracle Application Server, or OC4J:
 - **Using Oracle WebLogic Server:** Unpack the `routesserver.ear` file in your `$ORACLE_HOME/md/jlib` directory. Rename the `routesserver.ear` file and unpack its contents into a directory called `../routesserver.ear`. Rename the `web.war` file now found under the `$routesserver.ear/` directory and unpack its contents into a subdirectory called `../web.war`. Your directory structure should therefore be `$routesserver.ear/web.war/`.

After unpacking the `routesserver.ear` and `web.war` files, copy the `xmlparserv2.jar` file in your `$ORACLE_HOME/LIB/` directory into the `$routesserver.ear/web.war/WEB-INF/lib/` directory.

To deploy the `routesserver.ear` file, log on to the WLS console (for example, `http://<hostname>:7001/console`); and from Deployments, install the `routesserver.ear` file, accepting the name `routesserver` for the deployment and choosing the option to make the deployment accessible from a specified location.
 - **Using Oracle Application Server or OC4J:** Deploy the `routesserver.ear` file in your `$ORACLE_HOME/md/jlib` directory using the OracleAS or the standalone OC4J Application Server Control (for example, `http://<hostname>:8888/em`). You can deploy the `routesserver.ear` file in an existing OC4J instance, or you can create a new OC4J instance for the routing engine. In either case, enter `routesserver` for the Application Name during deployment.
3. Launch the Oracle routing engine welcome page in a Web browser using the URL `http://<hostname>:<port>/routesserver`. On the welcome page, select the Administration link and enter the administrator (`weblogic` or `oc4jadmin`) user name and password.

Note: If you are using WebLogic Server and if you are *not* using the default WebLogic administrator user name, you will need to edit the `weblogic.xml` file located in the `$routesserver.ear/web.war/WEB-INF/` directory. Replace `<principal-name>weblogic</principal-name>` with your WebLogic Server administrator user name, for example, `<principal-name>my_weblogic_admin</principal-name>`.

4. Limit the maximum number of concurrent requests (`max-http-connections`) value to 10. For example, with OC4J add the following element inside the `<application-server>` element in the `server.xml` file:

```
<max-http-connections value="10" />
```

It is important to limit the number of concurrent requests that the Oracle Route Server can process at any given time to prevent `java.lang.OutOfMemoryError` errors.

5. Configure the `web.xml` file, as explained in [Section 13.2.1](#), and save the changes.
6. If you deployed to Oracle WebLogic Server or Oracle Application Server, restart the routing engine.

If the welcome page is not displayed, ensure that the newly deployed routing engine service was successfully started. It is assumed that you are running

WebLogic Server 10.3.1.0 or later with an Oracle Database Release 11.2 or later `routeserver.ear` file; or that you are running Oracle AS or OC4J 10.1.3 or later with an Oracle 11g or later `routeserver.ear` file.

7. If you deployed to an OC4J instance, start OC4J using the following command options:

```
-server
-Xms<HEAP_SIZE>
-Xmx<HEAP_SIZE>
-XX:NewSize=<YOUNG_GENERATION_SIZE>
-XX:MaxNewSize=<YOUNG_GENERATION_SIZE>
-Dsun.rmi.dgc.server.gcInterval=3600000
-Dsun.rmi.dgc.client.gcInterval=3600000
-verbose:gc (optional)
```

<HEAP_SIZE> must be at least 512 MB, and has a recommended size of at least 1024 MB (1 GB). Make sure that this memory is physical memory and not virtual memory.

<YOUNG_GENERATION_SIZE> should be one-fourth (25%) of the <HEAP_SIZE> value.

`-verbose:gc` will print all minor and major Java garbage collections. Monitoring these statistics could be useful for memory resource planning. If you find that garbage collections are occurring frequently or are lasting several seconds, you probably need to allocate more physical memory to the Java VM.

Note: The amount of memory the Java VM will need depends mostly on two parameters: the `<max-http-connections value="..." />` element in the `<application-server>` element in `server.xml`, and the `partition_cache_size_limit` parameter in `web.xml`.

The following command is an example that starts OC4J. Note that the `-config` flag is an OC4J command line parameter, not a VM option.

```
c:\jdk1.5.0_06\bin\java -server
                        -Xms1024m
                        -Xmx1024m
                        -XX:NewSize=256m
                        -XX:MaxNewSize=256m
                        -Dsun.rmi.dgc.server.gcInterval=3600000
                        -Dsun.rmi.dgc.client.gcInterval=3600000
                        -verbose:gc
                        -jar c:\oc4j\j2ee\home\oc4j.jar
                        -config c:\oc4j\j2ee\home\config\server.xml
```

8. Verify your deployment by visiting the URL in the following format:

```
http://<hostname>:<port>/routeserver
```

You should see a welcome page. You should also see a message in the console window in which you started OC4J indicating that the Oracle Route Server was successfully initialized.

If you do not see a welcome message, the route server is probably not configured properly to run in your environment. In this case, edit the `<ROUTE_SERVER_HOME>/routeserver/web/WEB-INF/web.xml` file to reflect your environment

and your preferences. (The `web.xml` file is inside the `routeserver.ear` file, and it will not be visible until OC4J expands it into the route server directory structure under `<ROUTE_SERVER_HOME>`.) When you are finished editing, restart the routing engine or OC4J, and verify your deployment.

9. Consult the supplied examples. The page `http://<hostname>:<port>/routeserver/` has links at the bottom in a section named Test Samples. These examples demonstrate various capabilities of the Oracle Route Server. This is the best way to learn the XML API, which is described in [Section 13.3](#).

13.2.1 Configuring the web.xml File

You will probably need to make some changes to the default `web.xml` file that is included with Spatial, especially if you want to use settings from an older `web.xml` file or if you want to specify a language or use long ID values. You may want to edit or add some of the following parameters.

The parameters are grouped and listed here in the order in which they appear in the `web.xml` file. See also the descriptive comments in the `web.xml` file.

Route Server initialization parameters:

- `routeserver_schema_jdbc_connect_string`: Connect string to the database that contains routing data.
- `routeserver_schema_username`: Name of the user that was created to access Oracle routing data.
- `routeserver_schema_password`: Password for the user that was created to access Oracle routing data. You can obfuscate the password by preceding the password string with an exclamation point (!); if you do this, the password is obfuscated, and the `web.xml` file is rewritten the next time the routing engine is started.
- `routeserver_network_name`: TBS??? Network name for the routing engine.
- `routeserver_schema_connection_cache_min_limit`: Minimum number of database connections cached by the routing engine.
- `routeserver_schema_connection_cache_max_limit`: Maximum number of database connections cached by the routing engine.

Geocoder parameters:

- `geocoder_type`: Type of geocoder being used: `httpclient` (HTTP client; interacts with the Java servlet), `thinclient` (thin client; interacts with the Oracle Database geocoder), or `none` (no geocoder is provided).

If `geocoder_type` is `thinclient` and if the geocoder and the routing engine are in the same OC4J container, the geocoder must be configured to use a data source and to avoid connection pool conflicts.

Depending on the value of this parameter, examine the settings in the HTTP Client or Thin Client section of the `web.xml` file, and make any edits as appropriate. For example, if you specified `thinclient`, you can obfuscate the Oracle geocoder password in the same way as with the `routeserver_schema_password` parameter.

- Parameters used if `geocoder_type = httpclient`: `geocoder_http_url`, `geocoder_http_proxy_host`, `geocoder_http_proxy_port`

- Parameters used if `geocoder_type = thinclient`: `geocoder_schema_host`, `geocoder_schema_port`, `geocoder_schema_sid`, `geocoder_schema_username`, `geocoder_schema_password`, `geocoder_schema_mode`

Logging parameters:

- `log_filename`: Location (relative or absolute) and name of the log file.
- `log_level`: Type (and amount) of information to be written to the log file. From least to most information: FATAL, ERROR, WARN, INFO, DEBUG, or FINEST (all messages).
- `log_thread_name`: Whether to log the name of the thread that makes each entry.
- `log_time`: Whether to include the time with each entry.

Road description parameters:

- `max_speed_limit`: Maximum speed limit of any road segment, in meters per second. (34 meters per second is about 122 kilometers per hour or 75 miles per hour.)
- `local_road_threshold`: A number of miles (default = 25, minimum = 10). If the estimated distance in miles between source and destination nodes is less than or equal to this value, local roads are considered as an option; if the distance is greater than this value, local roads are not considered.

This parameter enables optimizations for short routes. Lower values can speed the routing engine performance by decreasing the size of the solution set to be searched, but can produce non-optimal short routes by causing the routing engine not to consider viable local road routes. Higher values (above the default of 25) can generate more accurate routes using local roads, but can slow the routing engine performance by increasing the size of the solution set to be searched.

- `highway_cost_multiplier`: The amount by which to make highways less attractive when computing routes with `route_preference` set to `local`.
- `driving_side`: R (the default) if traffic drives on the right side of the road, or L if traffic drives on the left side of the road.
- `language`: Default language to use to produce driving directions. The supported languages are English (the default), French, German, Italian, and Spanish.
- `long_ids`: TRUE (the default) causes ID values to have their length stored as LONG and not INTEGER data; FALSE causes ID values to have their length stored as INTEGER and not LONG data.

If you have routing data that was partitioned using an Oracle Database release before 11.1, the `long_ids` parameter value must be FALSE until the data is repartitioned using a current release.

- `distance_function_type`: `geodetic` for geodetic coordinate systems (such as SRID 8307 for longitude/latitude) or `euclidean` for projected coordinate systems.

Partitioning parameters:

- `partition_cache_size_limit`: Maximum number of partitions that the network partition cache can hold. If partitions are already in the cache, the routing engine will not have to load them from the database; however, if you set this value too high, you can encounter an "out of memory" error.
- `partition_table_name`: Name of the partition table that contains the network partitions. (The table is assumed to be in the schema associated with the

routesserver_schema_jdbc_connect_string, routesserver_schema_username, and routesserver_schema_password parameters.)

13.3 Routing Engine XML API

This section explains how to submit route requests in XML format to the routing engine, and it describes the XML document type definitions (DTDs) for the route requests (input) and responses (output). XML is widely used for transmitting structured documents using the HTTP protocol. If an HTTP request (GET or POST method) is used, it is assumed the request has a parameter named `xml_request` whose value is a string containing the XML document for the request.

A request to the routing engine servlet has the following format:

```
http://hostname:port/route-server-servlet-path?xml_request=xml-request
```

In this format:

- *hostname* is the network path of the server on which the routing engine is running.
- *port* is the port on which the application server listens.
- *route-server-servlet-path* is the routing engine servlet path (for example, `routesserver/servlet/RouteServerServlet`).
- *xml-request* is the URL-encoded XML request submitted using the HTML GET or POST method.

The input XML is required for all requests. The output will be an XML document.

In a simple *route* (as opposed to batch route) request, you must specify a route ID, and you can specify one or more of the following attributes:

- `route_preference`: `fastest` or `shortest` (default)
- `road_preference`: `highway` (default) or `local`
- `return_driving_directions` (whether to return driving directions): `true` or `false` (default)
- `return_hierarchical_directions` (whether to return hierarchical directions): `true` or `false` (default)
- `return_locations` (return the start and end locations of the route and any subroutes): `true` (default) or `false`
- `return_subroutes` (whether to return subroutes): `true` (default if a multi-address route, ignored for a single-address route) or `false`
- `return_route_geometry` (whether to return the line string coordinates for the route): `true` or `false` (default)
- `return_subroute_geometry` (whether to return the line string coordinates for each subroute): `true` or `false` (default if a multi-address route, ignored if a single-address route)
- `return_segment_geometry` (whether to return the line string coordinates for each maneuver in the route): `true` or `false` (default)
- `return_detailed_geometry`: `true` (default; returns detailed geometries) or `false` (returns generalized geometries)
- `language`: language used to generate driving directions (ENGLISH, FRENCH, GERMAN, ITALIAN, or SPANISH)

- `return_segment_edge_ids` (whether to return the edge ID values of the edges of each maneuver in the route): `true` or `false` (default)
- `return_route_edge_ids` (whether to return the edge ID values of the edges in the route): `true` or `false` (default)
- `return_subroute_edge_ids` (whether to return the edge ID values of the edges in each subroute): `true` or `false` (default if a multi-address route, ignored if a single-address route)
- `distance_unit`: `kilometer`, `mile` (default), or `meter`
- `time_unit`: `hour`, `minute` (default), or `second`
- `pre_geocoded_locations` (whether the start and end locations are input locations (address specifications or points) or previously geocoded locations): `true` (previously geocoded locations) or `false` (default; input locations)

In a *batch route* request, you must specify a request ID, a start location, and one or more end locations. Each location must have an ID attribute. You can also specify one or more of the following attributes for the batch route request:

- `route_preference`: `fastest` or `shortest` (default)
- `road_preference`: `highway` (default) or `local`
- `distance_unit`: `kilometer`, `mile` (default), or `meter`
- `time_unit`: `hour`, `minute` (default), or `second`
- `sort_by_distance` (whether to sort the returned routes in ascending order by distance of the end location from the start location): `true` or `false` (default)
- `cutoff_distance` (returning only routes where the end location is less than or equal to a specified number of distance units from the start location): (number; default = no limit)
- `pre_geocoded_locations` (whether the start and end locations are input locations (address specifications or points) or previously geocoded locations): `true` (previously geocoded locations) or `false` (default; input locations)

This section contains the following subsections:

- [Section 13.3.1, "Route Request and Response Examples"](#)
- [Section 13.3.2, "Route Request DTD"](#)
- [Section 13.3.3, "Route Response DTD"](#)
- [Section 13.3.4, "Batch Route Request and Response Examples"](#)
- [Section 13.3.5, "Batch Route Request DTD"](#)
- [Section 13.3.6, "Batch Route Response DTD"](#)

13.3.1 Route Request and Response Examples

This section contains XML examples of route requests and the responses generated by those requests. One request uses specified addresses, another uses points specified by longitude and latitude coordinates, and another uses previously geocoded locations. For reference information about the available elements and attributes, see [Section 13.3.2](#) for requests and [Section 13.3.3](#) for responses.

[Example 13-1](#) shows a request for the fastest route, preferably using highways, between two offices at specified addresses (in Waltham, Massachusetts and Nashua,

New Hampshire), with driving directions for each segment, and using miles for distances and minutes for times.

Example 13–1 Route Request with Specified Addresses

```
<?xml version="1.0" standalone="yes"?>
<route_request
  id="8"
  route_preference="fastest"
  road_preference="highway"
  return_driving_directions="true"
  distance_unit="mile"
  time_unit="minute">
  <start_location>
    <input_location id="1">
      <input_address>
        <us_form1
          street="1000 Winter St"
          lastline="Waltham, MA" />
        </input_address>
      </input_location></start_location>
    </end_location>
    <input_location id="2">
      <input_address>
        <us_form1
          street="1 Oracle Dr"
          lastline="Nashua, NH" />
        </input_address>
      </input_location>
    </end_location>
  </route_request>
```

[Example 13–2](#) shows the response generated by the request in [Example 13–1](#). (The output is reformatted for readability.)

Example 13–2 Route Response with Specified Addresses

```
<?xml version="1.0" encoding="UTF-8" ?>
<route_response>
  <route
    id="8"
    step_count="15"
    distance="29.855655894643636"
    distance_unit="mile"
    time="34.41252848307292"
    time_unit="minute">
    <segment
      sequence="1"
      instruction="Start out on WINTER ST (Going North)"
      distance="0.6715170911787637" time="1.1257004737854004"/>
    <segment
      sequence="2"
      instruction="Turn SLIGHT RIGHT onto RAMP (Going Northwest)"
      distance="0.05893317343308232"
      time="0.09879287083943684"/>
    <segment
      sequence="3"
      instruction="Turn RIGHT onto OLD COUNTY RD (Going Northeast)"
      distance="0.6890481152276999"
      time="1.6801289876302083"/>
```



```
<segment
  sequence="4"
  instruction="Turn RIGHT onto TRAPELO RD (Going Southeast)"
  distance="1.0062739119153126"
  time="1.686871592203776"/>
<segment
  sequence="5"
  instruction="Turn LEFT onto RAMP (Going North)"
  distance="0.3364944434303735"
  time="0.5640838623046875"/>
<segment
  sequence="6"
  instruction="Merge onto I-95/RT-128 (Going North)"
  distance="4.775246959324318"
  time="4.926156107584635"/>
<segment
  sequence="7"
  instruction="Continue on I-95/RT-128"
  distance="0.0"
  time="0.0"/>
<segment
  sequence="8"
  instruction="Stay STRAIGHT to go onto 32B/32A (Going East)"
  distance="0.27138218577176415"
  time="0.4549326578776042"/>
<segment
  sequence="9"
  instruction="Take EXIT 32A toward LOWELL"
  distance="0.043764782242279254"
  time="0.07336527506510417"/>
<segment
  sequence="10"
  instruction="Stay STRAIGHT to go onto RAMP (Going East)"
  distance="0.2770620621155161"
  time="0.4644541422526042"/>
<segment
  sequence="11"
  instruction="Turn LEFT onto US-3 (Going Northwest)"
  distance="20.664632308107564"
  time="21.317686971028646"/>
<segment
  sequence="12"
  instruction="Stay STRAIGHT to go onto EVERETT TPKE/US-3 (Going Northwest)"
  distance="0.006080380444913938"
  time="0.006272379557291667"/>
<segment
  sequence="13"
  instruction="Take EXIT 1 toward SO NASHUA"
  distance="0.550406717982974"
  time="0.9226765950520833"/>
<segment
  sequence="14"
  instruction="Turn LEFT onto SPIT BROOK RD (Going West)"
  distance="0.5031617978313553"
  time="1.0825419108072916"/>
<segment
  sequence="15"
  instruction="Turn RIGHT onto ORACLE DR (Going North)"
  distance="0.0016526518707758954"
  time="0.00886537532011668"/>
```

```

    </route>
</route_response>

```

Example 13–3 shows a request for the fastest route, preferably using highways, between two locations specified as longitude/latitude points, with driving directions for each segment, and using meters for distances and seconds for times. (The points are associated with two locations in San Francisco, California: the World Trade Center and 100 Flower Street.)

Example 13–3 Route Request with Specified Longitude/Latitude Points

```

<?xml version="1.0" standalone="yes"?>
<route_request id="8"
    route_preference="shortest"
    road_preference="highway"
    return_driving_directions="true"
    distance_unit="meter"
    time_unit="second"
    return_route_geometry="true"
    >
  <start_location>
    <input_location id="1" longitude="-122.39382" latitude="37.79518" />
  </start_location>
  <end_location>
    <input_location id="2" longitude="-122.4054826" latitude="37.7423566" />
  </end_location>
</route_request>

```

Example 13–4 shows the response generated by the request in **Example 13–3**. (The output is reformatted for readability.)

Example 13–4 Route Response with Specified Longitude/Latitude Points

```

?xml version="1.0" encoding="UTF-8" ?>
<route_response>
  <route id="8" step_count="11" distance="7196.72509765625" distance_unit="meter"
    time="521.2236328125" time_unit="second">
    <route_geometry>
      <LineString>
        <coordinates>
-122.39382,37.79518 -122.39382,37.79518 -122.39454,37.79601 -122.39467,37.79604
-122.39476,37.79604 -122.39484,37.79599 -122.39486,37.79591 -122.39484,37.79579
-122.39462,37.79539 -122.39425,37.79491 -122.39389,37.79462 -122.39338,37.79433
-122.39326,37.79424 -122.39275,37.79384 -122.39263,37.79371 -122.39174,37.79293
-122.39151,37.79274 -122.39142,37.79266 -122.3913,37.7925 -122.3912,37.79233
-122.39102,37.79184 -122.39093,37.79161 -122.39072,37.79128 -122.39049,37.79104
-122.39016,37.79076 -122.38878,37.78967 -122.38861,37.7895 -122.38839,37.7892
-122.38819,37.78877 -122.38813,37.78857 -122.38797,37.78783 -122.38796,37.78758
-122.38801,37.78709 -122.38819,37.78478 -122.38832,37.78477 -122.38841,37.78474
-122.38983,37.78361 -122.39127,37.78246 -122.39206,37.78184 -122.39261,37.78139
-122.39319,37.78094 -122.3943,37.7801 -122.39486,37.77968 -122.39534,37.7793
-122.39654,37.77833 -122.39876,37.77657 -122.39902,37.77639 -122.40033,37.77537
-122.40096,37.77483 -122.40151,37.7744 -122.40205,37.77396 -122.40226,37.7738
-122.40266,37.77349 -122.40321,37.77305 -122.40376,37.77262 -122.40543,37.77129
-122.40578,37.77101 -122.40599,37.77083 -122.40699,37.77006 -122.40767,37.76953
-122.40774,37.76947 -122.40781,37.7694 -122.40786,37.76932 -122.40788,37.76922
-122.40788,37.76913 -122.40786,37.76897 -122.40785,37.76883 -122.40779,37.76838
-122.40767,37.7671 -122.40756,37.76577 -122.40743,37.76449 -122.40734,37.76321
-122.40722,37.76193 -122.40709,37.76067 -122.40695,37.75937 -122.40678,37.75776
-122.4067,37.75684 -122.40663,37.75617 -122.40647,37.75458 -122.40644,37.75428

```

```

-122.40632,37.75299 -122.4062,37.75174 -122.40617,37.75138 -122.40614,37.75103
-122.40606,37.75066 -122.40565,37.74987 -122.40529,37.74937 -122.40518,37.74924
-122.40506,37.74913 -122.4045,37.74873 -122.4041,37.74845 -122.40393,37.74827
-122.40384,37.74815 -122.40378,37.74801 -122.40375,37.74785 -122.40381,37.74762
-122.40397,37.74719 -122.4043,37.74633 -122.40434,37.74618 -122.40434,37.74603
-122.40431,37.74594 -122.4042,37.74554 -122.40416,37.7453 -122.40417,37.74515
-122.40431,37.74464 -122.40445,37.74427 -122.40461,37.74393 -122.40479,37.74362
-122.40522,37.74304 -122.40482,37.74282 -122.40517,37.74233
-122.40545613036156,37.742431337836386
  </coordinates>
</LineString>
</route_geometry>
<segment sequence="1" instruction="Start out on FERRY BLDG/FERRY
  PLZ/HERB CAEN WAY/THE EMBARCADERO (Going Northwest)"
  distance="111.84008026123047" time="6.990005016326904"/>
<segment sequence="2" instruction="Turn LEFT onto RAMP (Going
  Southwest)" distance="51.30750274658203" time="4.664318561553955"/>
<segment sequence="3" instruction="Turn LEFT onto HERB CAEN
  WAY/THE EMBARCADERO (Going Southeast)"
  distance="902.3695068359375" time="56.39809036254883"/>
<segment sequence="4" instruction="Turn SLIGHT RIGHT onto THE
  EMBARCADERO (Going Southeast)" distance="534.7628173828125"
  time="33.42267608642578"/>
<segment sequence="5" instruction="Turn RIGHT onto BRANNAN ST
  (Going Southwest)" distance="2454.0565185546875"
  time="219.57013702392578"/>
<segment sequence="6" instruction="Turn SLIGHT LEFT onto POTRERO AVE
  (Going South)" distance="2066.54541015625" time="129.15908813476562"/>
<segment sequence="7" instruction="Turn SLIGHT LEFT onto BAY SHORE
  BLVD (Going Southeast)" distance="747.060546875"
  time="46.6912841796875"/>
<segment sequence="8" instruction="Stay STRAIGHT to go onto BAY SHORE
  BLVD/BAYSHORE BLVD (Going South)" distance="195.7578125"
  time="12.23486328125"/>
<segment sequence="9" instruction="Turn LEFT onto OAKDALE AVE
  (Going Southeast)" distance="42.8857421875" time="3.898712158203125"/>
<segment sequence="10" instruction="Turn RIGHT onto PATTERSON ST
  (Going Southwest)" distance="62.525390625" time="5.68414306640625"/>
<segment sequence="11" instruction="Turn RIGHT onto FLOWER ST (Going
  West)" distance="27.61372947692871" time="2.5103390216827393"/>
</route>
</route_response>

```

[Example 13–5](#) shows a request for the route, with driving directions, where the start and end locations are previously geocoded locations that are about one-half mile apart in Boston, Massachusetts.

Example 13–5 Route Request with Previously Geocoded Locations

```

<?xml version="1.0" standalone="yes"?>
<route_request id="8"
  route_preference="shortest"
  road_preference="highway"
  return_driving_directions="true"
  distance_unit="mile"
  time_unit="minute"
  pre_geocoded_locations="true">
  <start_location>
    <pre_geocoded_location id="1">
      <edge_id>22161661</edge_id>

```

```

        <percent>.5</percent>
        <side>L</side>
    </pre_geocoded_location>
</start_location>
<end_location>
    <pre_geocoded_location id="2">
        <edge_id>22104391</edge_id>
        <percent>.5</percent>
        <side>R</side>
    </pre_geocoded_location>
</end_location>
</route_request>

```

Example 13–6 shows the response to the request in [Example 13–5](#). (The output is reformatted for readability.)

Example 13–6 Route Response with Previously Geocoded Locations

```

<?xml version="1.0" encoding="UTF-8" ?>
<route_response>
  <route
    id="8"
    step_count="5"
    distance="0.6193447379707987"
    distance_unit="mile"
    time="1.6662169138590495"
    time_unit="minute">
    <segment
      sequence="1"
      instruction="Start out on HUNTINGTON AVE (Going Southeast)"
      distance="0.0059065276259536855"
      time="0.01440208355585734"/>
    <segment
      sequence="2"
      instruction="Turn LEFT onto AVENUE OF THE ARTS/HUNTINGTON AVE/RT-9 (Going
      Northeast)"
      distance="0.020751234891437903"
      time="0.050598426659901934"/>
    <segment
      sequence="3"
      instruction="Turn RIGHT onto PUBLIC ALLEY 405 (Going Southeast)"
      distance="0.053331456545578096"
      time="0.286087703704834"/>
    <segment
      sequence="4"
      instruction="Turn RIGHT onto ST BOTOLPH ST (Going Southwest)"
      distance="0.028921701076542888"
      time="0.07052075068155925"/>
    <segment
      sequence="5"
      instruction="Turn RIGHT onto MASSACHUSETTS AVE (Going Northwest)"
      distance="0.5104338249425094"
      time="1.2446078459421794"/>
  </route>
</route_response>

```

13.3.2 Route Request DTD

The following is the complete DTD for a route request. The main elements and attributes of the DTD are explained in sections that follow.

```

<?xml version="1.0" encoding="UTF-8"?>
<!-- geocoder.dtd includes gmlfeature.dtd. These define the
      ELEMENTS input_address and those in Feature, FeatureMember,

```

```

        and FeatureCollection that are used in geoFeature,
        geoFeatureCollection, and geoFeatureMember.
-->
<!ENTITY % GEOCODERDTD SYSTEM "geocoder.dtd">
%GEOCODERDTD;

<!--
    input_location: specify an input address to the geocoder
    input_address: specify a location using a street address
    Point: specify a location using its longitude/latitude

    (The input_location, input_address and Point elements are defined in
    geocoder.dtd. GeometryClasses is defined in gmlgeometry.dtd.)
-->
<!ELEMENT route_request (start_location, location*, end_location)>
<!ATTLIST route_request
    vendor CDATA "Oracle"
    id CDATA #REQUIRED
    route_preference (FASTEST|SHORTEST) #IMPLIED
    road_preference (HIGHWAY|LOCAL) #IMPLIED
    return_driving_directions (TRUE|FALSE) #IMPLIED
    return_hierarchical_driving_directions (TRUE|FALSE) #IMPLIED
    return_locations (TRUE|FALSE) #IMPLIED
    return_subroutes (TRUE|FALSE) #IMPLIED
    return_route_geometry (TRUE|FALSE) #IMPLIED
    return_subroute_geometry (TRUE|FALSE) #IMPLIED
    return_segment_geometry (TRUE|FALSE) #IMPLIED
    return_detailed_geometry (TRUE|FALSE) #IMPLIED
    return_route_edge_ids (TRUE|FALSE) #IMPLIED
    return_subroute_edge_ids (TRUE|FALSE) #IMPLIED
    return_route_segment_ids (TRUE|FALSE) #IMPLIED
    language (ENGLISH|FRENCH|GERMAN|ITALIAN|SPANISH) #IMPLIED
    distance_unit (KM|MILE|METER) #IMPLIED
    time_unit (HOUR|MINUTE|SECOND) #IMPLIED
    pre_geocoded_locations (TRUE|FALSE) #IMPLIED>
    driving_directions_detail (LOW|MEDIUM|HIGH) #IMPLIED

<!-- The following are alternatives for specifying the location. Use
    input_location when you want to represent a location with a
    street address (input_address) or longitude/latitude (Point).
    If you have already geocoded the location,
    you can use information from the geocoder response to
    construct a pre_geocoded_location element.
    The geocoder returns:
        - An edge_id (integer that is the road segment identifier)
        - A side ('L' or 'R' - left or right side)
        - A percent (floating-point number 0.0 to 1.0 representing
        the fraction of the length from the start of the road
        segment to this location.
-->
<!ELEMENT pre_geocoded_location (edge_id, percent, side)>
<!ATTLIST pre_geocoded_location id CDATA #REQUIRED>

<!ELEMENT start_location (input_location|pre_geocoded_location|)>
<!ELEMENT location (input_location|pre_geocoded_location|)>
<!ELEMENT end_location (input_location|pre_geocoded_location|)>

```

13.3.2.1 route_request Element

The `<route_request>` element has the following definition:

```
<!ELEMENT route_request (start_location, location*, end_location)>
```

The root element of a route request is always named `route_request`.

The `<start_location>` child element specifies the start location for the route, as an address specification, a geocoded address, or longitude/latitude coordinates.

The `<location>` child element specifies a location for a segment, as an address specification, a geocoded address, or longitude/latitude coordinates. If there are no `<location>` elements, it is a single-address route; if there are one or more `<location>` elements, it is a multi-address route.

The `<end_location>` child element specifies the end location for the route, as an address specification, a geocoded address, or longitude/latitude coordinates.

In a route request:

- If `<start_location>` is an address specification or longitude/latitude coordinates, each `<end_location>` and `<location>` element can be either an address specification or longitude/latitude coordinate; however, it cannot be a geocoded address.
- If `<start_location>` is a geocoded address, `<end_location>` and any `<location>` specifications must be geocoded addresses.

13.3.2.2 route_request Attributes

The root element `<route_request>` has a number of attributes, most of them optional. The attributes are defined as follows:

```
<!ATTLIST route_request
  vendor CDATA "Oracle"
  id CDATA #REQUIRED
  route_preference (FASTEST|SHORTEST) #IMPLIED
  road_preference (HIGHWAY|LOCAL) #IMPLIED
  return_driving_directions (TRUE|FALSE) #IMPLIED
  return_hierarchical_driving_directions (TRUE|FALSE) #IMPLIED
  return_locations (TRUE|FALSE) #IMPLIED
  return_subroutes (TRUE|FALSE) #IMPLIED
  return_route_geometry (TRUE|FALSE) #IMPLIED
  return_subroute_geometry (TRUE|FALSE) #IMPLIED
  return_segment_geometry (TRUE|FALSE) #IMPLIED
  return_detailed_geometry (TRUE|FALSE) #IMPLIED
  return_route_edge_ids (TRUE|FALSE) #IMPLIED
  return_subroute_edge_ids (TRUE|FALSE) #IMPLIED
  return_route_segment_ids (TRUE|FALSE) #IMPLIED
  language (ENGLISH|FRENCH|GERMAN|ITALIAN|SPANISH) #IMPLIED
  distance_unit (KM|MILE|METER) #IMPLIED
  time_unit (HOUR|MINUTE|SECOND) #IMPLIED
  pre_geocoded_locations (TRUE|FALSE) #IMPLIED>
  driving_directions_detail (LOW|MEDIUM|HIGH) #IMPLIED
```

`vendor` is an optional attribute whose default value identifies the routing provider as Oracle.

`id` is a required attribute that specifies an identification number to be associated with the request.

`route_preference` is an optional attribute that specifies whether you want the route with the lowest estimated driving time (`FASTEST`) or the route with the shortest driving distance (`SHORTEST`, the default).

`road_preference` is an optional attribute that specifies whether you want the route to use highways (`HIGHWAY`, the default) or local roads (`LOCAL`) when a choice is available.

`return_driving_directions` is an optional attribute that specifies whether you want driving directions for the route. `TRUE` returns driving directions; `FALSE` (the default) does not return driving directions.

`return_hierarchical_driving_directions` is an optional attribute that specifies whether you want driving directions for the route returned in an expandable and collapsible hierarchy. `TRUE` returns driving directions in an expandable and collapsible hierarchy; `FALSE` (the default) returns driving directions in a list with no hierarchy.

`return_locations` is an optional attribute that specifies whether to return the start and end locations of the route and any subroutes. `TRUE` (the default) returns these locations; `FALSE` does not return these locations.

`return_subroutes` is an optional attribute that specifies whether to return subroutes is a multi-address route. `TRUE` (the default for multi-address routes) returns subroutes; `FALSE` does not return subroutes. (This attributed is ignored for single-address routes.)

`return_route_geometry` is an optional attribute that specifies whether you want the coordinates of each line string that represents a maneuver in the route. `TRUE` returns the coordinates; `FALSE` (the default) does not return the coordinates.

`return_subroute_geometry` is an optional attribute that specifies whether you want the coordinates of each line string that represents a maneuver in each subroute. `TRUE` returns the coordinates; `FALSE` (the default for multi-address routes) does not return the coordinates. (This attributed is ignored for single-address routes.)

`return_segment_geometry` is an optional attribute that specifies whether you want the coordinates of the line string that represents the route. `TRUE` returns the coordinates; `FALSE` (the default) does not return the coordinates. If `return_segment_geometry` is `TRUE`, driving directions for the route are returned regardless of the value of the `return_route_geometry` attribute.

`return_detailed_geometry` is an optional attribute that indicates the level of detail to be included in returned geometries. `TRUE` (the default) returns detailed geometries; `FALSE` returns generalized geometries (usually with fewer coordinates).

`return_route_edge_ids` is an optional attribute that specifies whether you want the edge ID values of the edges in the route. `TRUE` returns the edge ID values; `FALSE` (the default) does not return the edge ID values.

`return_subroute_edge_ids` is an optional attribute that specifies whether you want the edge ID values of the edges in the subroutes. `TRUE` returns the edge ID values; `FALSE` (the default for multi-address routes) does not return the edge ID values. (This attributed is ignored for single-address routes.)

`return_segment_edge_ids` is an optional attribute that specifies whether you want the edge ID values of the edges of all maneuvers in the route. `TRUE` returns the edge ID values; `FALSE` (the default) does not return the edge ID values. If `return_segment_edge_ids` is `TRUE`, edge ID values are returned regardless of the value of the `return_route_edge_ids` attribute.

language is an optional attribute that overrides the default language used to generate the driving directions. The default language for is set in the `web.xml` file; you can use this attribute to override the default on a per-request basis. The following attribute values are supported: ENGLISH, FRENCH, GERMAN, ITALIAN, and SPANISH.

distance_unit is an optional attribute that specifies the unit of measure for distance values that are returned: KM for kilometer, MILE (the default) for mile, or METER for meter.

time_unit is an optional attribute that specifies the unit for time values that are returned: HOUR for hour, MINUTE (the default) for minute, or SECOND for second.

pre_geocoded_locations is an optional attribute that indicates how the start and end locations are specified. TRUE means that both are previously geocoded locations specified using the `<pre_geocoded_location>` element; FALSE (the default) means that both are addresses specified using the `<input_location>` element.

driving_directions_detail is an optional attribute that influences the level of detail and the number of separate steps in driving instructions. The available values are HIGH (most details and steps), MEDIUM (the default), and LOW (fewest details and steps). For example, LOW might treat a segment as a single step even if it involves slight maneuvers to the right or left. The effect of a value for this attribute on the length of returned driving directions will vary, depending on the exact names of elements and maneuvers. This attribute is ignored if you do not specify TRUE for `return_driving_directions` or `return_hierarchical_driving_directions`.

Note: The default level of detail changed in Oracle Database release 11.1, to provide fewer details and steps than before. If you want to have the same level of detail as in a previous release that did not have the `driving_directions_detail` attribute, specify HIGH for the `driving_directions_detail` attribute.

13.3.2.3 input_location Element

The `<input_location>` element specifies an address in a format that satisfies the Oracle Spatial geocoding request DTD, which is described in [Section 11.7.2](#). You can specify the input location using either the `<Point>` element or the `<input_address>` element. [Example 13-1](#) in [Section 13.3.1](#) shows the start and end addresses specified using the `<input_location>` element and its child element `<input_address>`.

To use the `<input_location>` element, you must ensure that the value of the `pre_geocoded_locations` attribute is FALSE (the default) in the `<route_request>` element. You can use the `<Point>` and `<input_address>` elements together in a request.

13.3.2.4 pre_geocoded_location Element

The `<pre_geocoded_location>` element specifies a geocoded location in terms of how far along a street (an edge) the address is and on which side of the street. [Example 13-5](#) in [Section 13.3.1](#) shows the start and end addresses specified using the `<pre_geocoded_location>` element.

To use the `<pre_geocoded_location>` element, you must specify `pre_geocoded_locations="TRUE"` in the `<route_request>` element, and you must use the `<pre_geocoded_location>` element to specify both the start and end locations.

13.3.3 Route Response DTD

The following is the complete DTD for a route response:

```
<?xml version="1.0" encoding="UTF-8"?>
<!-- route_response DTD includes the gmlgeometry DTD
      as an external entity reference.
-->
<!ENTITY % GMLGEOMETRYDTD SYSTEM "gmlgeometry.dtd">
  %GMLGEOMETRYDTD;

<!ELEMENT route_response (route | router_error)>

<!ELEMENT route (route_geometry?, segment+)>
<!-- ATTLLIST route id CDATA #REQUIRED
      step_count CDATA #IMPLIED
      time CDATA #IMPLIED
      distance CDATA #IMPLIED-->

<!ELEMENT router_error EMPTY>
<!-- ATTLLIST router_error
      id CDATA #REQUIRED
      error_code CDATA #IMPLIED
      error_msg CDATA #IMPLIED-->

<!ELEMENT route_geometry (LineString | MultiLineString)?>

<!ELEMENT route_edge_ids (EdgeIDs)?>

<!ELEMENT segment segment*, (LineString | MultiLineString)?>
<!-- ATTLLIST segment sequence CDATA #REQUIRED
      instruction CDATA #IMPLIED
      time CDATA #IMPLIED
      distance CDATA #IMPLIED-->

<!ELEMENT segment_geometry (LineString | MultiLineString)?>

<!ELEMENT segment_edge_ids (EdgeIDs)?>
```

13.3.4 Batch Route Request and Response Examples

This section contains XML examples of batch route requests and the responses generated by those requests. One request uses specified addresses, and the other request uses previously geocoded locations. For reference information about the available elements and attributes, see [Section 13.3.5](#) for requests and [Section 13.3.6](#) for responses.

[Example 13–7](#) shows a batch route request using specified addresses. The request is for the fastest routes, preferably using highways, between an office in Waltham, Massachusetts and three end locations (an Oracle office in Nashua, New Hampshire; the town offices in Concord, Massachusetts; and Boston City Hall), using miles for distances and minutes for times. The request calls for the returned routes to be sorted by distance between the start and end location, and for no routes over 35 miles to be returned.

Example 13–7 Batch Route Request with Specified Addresses

```
<?xml version="1.0" standalone="yes"?>
<batch_route_request
  id="8"
```

```

        route_preference="fastest"
        road_preference="highway"
        return_driving_directions="false"
        sort_by_distance = "true"
        cutoff_distance="35"
        distance_unit="mile"
        time_unit="minute">
<start_location>
  <input_location
    id="1">
    <input_address>
      <us_form1
        street="1000 Winter St"
        lastline="Waltham, MA" />
    </input_address>
  </input_location>
</start_location>
<end_location>
  <input_location id="10">
    <input_address>
      <us_form1
        street="1 Oracle Dr"
        lastline="Nashua, NH" />
    </input_address>
  </input_location>
</end_location>
<end_location>
  <input_location
    id="11">
    <input_address>
      <us_form1
        street="22 Monument Sq"
        lastline="Concord, MA" />
    </input_address>
  </input_location>
</end_location>
<end_location>
  <input_location
    id="12">
    <input_address>
      <us_form1
        street="1 City Hall Plaza"
        lastline="Boston, MA" />
    </input_address>
  </input_location>
</end_location>
</batch_route_request>

```

[Example 13-8](#) shows the response generated by the request in [Example 13-7](#). (The output is reformatted for readability.)

Example 13-8 Batch Route Response with Specified Addresses

```

<?xml version="1.0" encoding="UTF-8" standalone="yes" ?>
<batch_route_response
  id="8">
  <route
    id="11"
    step_count="0"
    distance="6.637544152543032"

```

```

        distance_unit="mile"
        time="10.53597412109375"
        time_unit="minute" />
<route
  id="12"
  step_count="0"
  distance="17.204805418116575"
  distance_unit="mile"
  time="24.47645467122396"
  time_unit="minute" />
<route
  id="10"
  step_count="0"
  distance="29.855655894643636"
  distance_unit="mile"
  time="34.41252848307292"
  time_unit="minute" />
</batch_route_response>

```

[Example 13-9](#) shows a batch route request using previously geocoded locations. The request is for the shortest routes, preferably using highways, between one location and three other locations, using miles for distances and minutes for times. The request calls for the returned routes to be sorted by distance between the start and end location, and for no routes over 50 miles to be returned.

Example 13-9 Batch Route Request with Previously Geocoded Locations

```

<?xml version="1.0" standalone="yes"?>
<batch_route_request id="8"
  route_preference="shortest"
  road_preference="highway"
  return_driving_directions="false"
  distance_unit="mile"
  time_unit="minute"
  pre_geocoded_locations="true"
  cutoff_distance="50"
  sort_by_distance="true">
  <start_location>
    <pre_geocoded_location id="1">
      <edge_id>22161661</edge_id>
      <percent>.5</percent>
      <side>L</side>
    </pre_geocoded_location>
  </start_location>
  <end_location>
    <pre_geocoded_location id="2">
      <edge_id>22104391</edge_id>
      <percent>.5</percent>
      <side>R</side>
    </pre_geocoded_location>
  </end_location>
  <end_location>
    <pre_geocoded_location id="3">
      <edge_id>22160808</edge_id>
      <percent>.5</percent>
      <side>L</side>
    </pre_geocoded_location>
  </end_location>
  <end_location>
    <pre_geocoded_location id="4">

```

```

        <edge_id>22325991</edge_id>
        <percent>.5</percent>
        <side>R</side>
    </pre_geocoded_location>
</end_location>
</batch_route_request>

```

Example 13–10 shows the response to the request in **Example 13–9**. Only two routes are returned, because the third route is longer than the specified cutoff distance of 50 miles. (The output is reformatted for readability.)

Example 13–10 Batch Route Response with Previously Geocoded Locations

```

<?xml version="1.0" encoding="UTF-8" standalone="yes" ?>
<batch_route_response
  id="8">
  <route
    id="2"
    step_count="0"
    distance="0.6193447379707987"
    distance_unit="mile"
    time="1.6662169138590495"
    time_unit="minute" />
  <route
    id="4"
    step_count="0"
    distance="41.342018851363946"
    distance_unit="mile"
    time="47.95714518229167"
    time_unit="minute" />
</batch_route_response>

```

13.3.5 Batch Route Request DTD

The following is the complete DTD for a batch route request. The main elements and attributes of the DTD are explained in sections that follow.

```

<!ENTITY % GEOCODERDTD SYSTEM "geocoder.dtd">
%GEOCODERDTD;
<!-- input_location element is defined in geocoder.dtd -->

<!ELEMENT batch_route_request (start_location, end_location+)>
<!ATTLIST batch_route_request
  vendor CDATA "Oracle"
  id CDATA #REQUIRED
  route_preference (FASTEST | SHORTEST ) #IMPLIED
  road_preference (HIGHWAY | LOCAL) #IMPLIED
  distance_unit (KM | MILE | METER ) #IMPLIED
  time_unit (HOUR | MINUTE | SECOND) #IMPLIED
  sort_by_distance (TRUE | FALSE) #IMPLIED
  cutoff_distance CDATA #IMPLIED>

<!-- The following are alternatives for specifying the location. Use
input_location when you want to represent a location with a
street address (input_address) or by longitude/latitude (Point).
If you have already geocoded the location,
you can use information from the geocoder response to
construct a pre_geocoded_location element.
The geocoder returns:
  - an edge_id (integer that is the road segment identifier)

```

```

    - a side ('L' or 'R' - left or right side)
    - a percent (floating-point number 0.0 to 1.0 representing
      the fraction of the length from the start of the road
      segment to this location.
-->
<!ELEMENT pre_geocoded_location (edge_id, percent, side)>
<!ATTLIST pre_geocoded_location id CDATA #REQUIRED>

<!ELEMENT start_location (input_location|pre_geocoded_location)>
<!ELEMENT end_location (input_location|pre_geocoded_location)>
<!-- IMPORTANT VALIDITY CONSTRAINT: each of the input_location
elements that are children of end_location MUST contain
the id attribute. Normally, the id attribute is optional.
If an id is not present, an exception will result.
Also, each id must be unique within a batch_route_request.
Otherwise, the request will yield unpredictable results.
-->

```

13.3.5.1 batch_route_request Element

The `<batch_route_request>` element has the following definition:

```
<!ELEMENT batch_route_request (start_location, end_location+)>
```

The root element of a route request is always named `batch_route_request`.

The `<start_location>` child element specifies the start location for the route, as an address specification, a geocoded address, or longitude/latitude point.

Each of the one or more `<end_location>` child elements specifies the end location for the route, as an address specification, a geocoded address, or longitude/latitude point.

13.3.5.2 batch_route_request Attributes

The root element `<batch_route_request>` has a number of attributes, most of them optional. The attributes are defined as follows:

```
<!ATTLIST batch_route_request
  vendor CDATA "Oracle"
  id CDATA #REQUIRED
  route_preference (FASTEST|SHORTEST) #IMPLIED
  road_preference (HIGHWAY|LOCAL) #IMPLIED
  distance_unit (KM|MILE|METER) #IMPLIED
  time_unit (HOUR|MINUTE|SECOND) #IMPLIED
  sort_by_distance (TRUE | FALSE) #IMPLIED
  cutoff_distance CDATA #IMPLIED>
pre_geocoded_locations (TRUE|FALSE) #IMPLIED>
```

Most `<batch_route_request>` attributes have the same meaning as their counterpart `<route_request>` attributes, which are explained in [Section 13.3.5.2](#). In addition, the `sort_by_distance` and `cutoff_distance` attributes do not apply to single route requests.

`sort_by_distance` is an optional attribute that specifies whether you want the routes returned in ascending order by distance of the end location from the start location. `TRUE` sorts the returned routes by distance; `FALSE` (the default) does not sort the returned routes by distance.

`cutoff_distance` is an optional attribute that causes routes to be returned only where the end location is less than or equal to a specified distance from the start location. By default, all routes are returned.

Note: If a route is within the specified `cutoff_distance` value but would generate a `<router_error>` element in the response (see [Section 13.3.6](#)), the route is removed from the response and not shown.

13.3.6 Batch Route Response DTD

The following is the complete DTD for a batch route response:

```
<?xml version="1.0" encoding="UTF-8"?>
<!ELEMENT batch_route_response (route | route_error)+ >
<!ATTLIST batch_route_response id CDATA #REQUIRED>
<!ELEMENT route EMPTY>
<!ATTLIST route
  id CDATA #REQUIRED
  step_count CDATA #IMPLIED
  distance CDATA #IMPLIED
  distance_unit CDATA #IMPLIED
  time CDATA #IMPLIED
  time_unit CDATA #IMPLIED>
<!ELEMENT router_error EMPTY>
<!ATTLIST router_error
  id CDATA #REQUIRED
  error_code CDATA #IMPLIED
  error_msg CDATA #IMPLIED>
```

13.4 Data Structures Used by the Routing Engine

Each database user of the routing engine must have the following tables in its schema:

- EDGE
- NODE
- PARTITION
- SIGN_POST

The EDGE and NODE tables store edge and node information about the street network used by the routing engine. To understand how edges and nodes are used to represent street segments, intersections, and other entities in a street network, you must be familiar with the Oracle Spatial network data model, which is described in *Oracle Spatial Topology and Network Data Models Developer's Guide*.

The following sections describe the tables used by the routing engine, in alphabetical order by table name.

13.4.1 EDGE Table

The EDGE table contains one row for each directed edge in a street network. Each street segment (a part of a road between two nodes) is an undirected edge that corresponds to one or more directed edges in the EDGE table. The EDGE table contains the columns shown in [Table 13-1](#).

Table 13-1 EDGE Table

Column Name	Data Type	Description
EDGE_ID	NUMBER	Edge ID number.
START_NODE_ID	NUMBER	Node ID number of the start node of this edge.

Table 13–1 (Cont.) EDGE Table

Column Name	Data Type	Description
END_NODE_ID	NUMBER	Node ID number of the end node of this edge.
PARTITION_ID	NUMBER	Partition ID number of the network partition that contains this edge.
FUNC_CLASS	NUMBER	Functional road class: a number from 1 through 5, with 1 indicating a large, high-speed, high-volume road, and each successive class generally smaller in size, speed, and volume. Class 2 roads have consistent speeds and are used to get traffic to and from class 1 roads. Class 3 roads have high volume and are used to connect class 2 roads. Class 4 roads move volumes of traffic between neighborhoods (for example, a busy main road in a city). Class 5 roads are all other roads (for example, a small, low-volume street in a neighborhood).
LENGTH	NUMBER	Length of this edge, in meters.
SPEED_LIMIT	NUMBER	Assigned speed limit for this edge, in meters per second.
GEOMETRY	SDO_GEOMETRY	Line string geometry representing this edge, with the coordinates ordered from the start node to the end node.
NAME	VARCHAR2(128)	Name of this edge.
DIVIDER	VARCHAR2(1)	A value of N indicates that the edge is not divided; other values indicate whether, where, and how turns are allowed on the divided edge. (The routing engine currently considers only whether the edge is divided or not.)

13.4.2 NODE Table

The NODE table contains one row for each node that is the start node or end node of one or more edges in the street network. A node often corresponds to an intersection (the intersection of two edges); however, a node can be independent of any intersection (for example, the end of a "dead end" or "no outlet" street). The NODE table contains the columns shown in [Table 13–2](#).

Table 13–2 NODE Table

Column Name	Data Type	Description
NODE_ID	NUMBER	Node ID number.
GEOMETRY	SDO_GEOMETRY	Point geometry representing this node.
PARTITION_ID	NUMBER	Partition ID number of the network partition that contains this node.

13.4.3 PARTITION Table

The PARTITION table is generated by Oracle based on the contents of the EDGE and NODE tables. The PARTITION table contains the columns shown in [Table 13–3](#).

Table 13–3 PARTITION Table

Column Name	Data Type	Description
PARTITION_ID	NUMBER	Partition ID number.

Table 13–3 (Cont.) PARTITION Table

Column Name	Data Type	Description
SUBNETWORK	BLOB	Part of the network included in this partition.
NUM_NODES	NUMBER	Number of nodes in this partition.
NUM_NON_BOUNDARY_EDGES	NUMBER	Number of edges in this partition that are edges that are completely contained within the partition.
NUM_OUTGOING_BOUNDARY_EDGES	NUMBER	Number of edges in this partition that start in this partition and terminate in another partition. (An edge cannot be in more than two partitions; for example, an edge cannot start in one partition, go through a second partition, and end in a third partition.)
NUM_INCOMING_BOUNDARY_EDGES	NUMBER	Number of edges in this partition that start in another partition and terminate in this partition. (An edge cannot be in more than two partitions; for example, an edge cannot start in one partition, go through a second partition, and end in a third partition.)

13.4.4 SIGN_POST Table

The SIGN_POST table stores sign information that is used to generate driving directions. For example, a sign might indicate that Exit 33A on US Route 3 South goes toward Winchester. A SIGN_POST row might correspond to a physical sign at an exit ramp on a highway, but it does not need to correspond to a physical sign. The SIGN_POST table contains the columns shown in [Table 13–4](#).

Table 13–4 SIGN_POST Table

Column Name	Data Type	Description
FROM_EDGE_ID	NUMBER	Edge ID number of the edge to which this sign applies (for example, the street segment containing the exit ramp).
TO_EDGE_ID	NUMBER	Edge ID number of the edge to which this sign points (for example, the street segment to which the exit ramp leads).
RAMP	VARCHAR2(64)	Ramp text (for example, US-3 SOUTH).
EXIT	VARCHAR2(8)	Exit number (for example, 33A).
TOWARD	VARCHAR2(64)	Text indicating where the exit is heading (for example, WINCHESTER).

OpenLS Support

This chapter describes the Oracle Spatial support for Web services based on the Open Location Services Initiative (OpenLS) of the Open GeoSpatial Consortium (OGC), versions 1.0 and 1.1. For a description of OpenLS, see <http://www.opengeospatial.org/standards/ols>, which includes links for downloads and schemas.

This chapter includes the following major sections:

- [Section 14.1, "Supported OpenLS Services"](#)
- [Section 14.2, "OpenLS Application Programming Interfaces"](#)
- [Section 14.3, "OpenLS Service Support and Examples"](#)

Note: Before you use OpenLS, be sure that you understand the concepts described in [Chapter 10, "Introduction to Spatial Web Services"](#), and that you have performed any necessary configuration work as described in that chapter.

14.1 Supported OpenLS Services

Spatial supports the following OGC OpenLS services:

- Location Utility Service (geocoding)
- Presentation Service (mapping)
- Route Service (driving directions)
- Directory Service (YP, or "Yellow Pages")

Spatial does not currently support the OGC OpenLS Gateway Service (mobile positioning).

For all supported services except Directory Service (YP, or Yellow Pages), you must first perform certain operations, which might included acquiring and loading third-party data, as well as configuring and deploying underlying technology on which the Spatial OpenLS service is based. [Table 14–1](#) lists the Spatial OpenLS services, and the chapter or manual that documents the requirements and underlying technologies.

Table 14–1 *Spatial OpenLS Services Dependencies*

Spatial OpenLS Service	Depends On	Documented In
Geocoding	Geocoding metadata and data	Chapter 11, "Geocoding Address Data"

Table 14–1 (Cont.) Spatial OpenLS Services Dependencies

Spatial OpenLS Service	Depends On	Documented In
Mapping	Oracle MapViewer	<i>Oracle Fusion Middleware User's Guide for Oracle MapViewer</i>
Driving directions	Routing engine	Chapter 13, "Routing Engine"
Business directory (YP, or Yellow Pages)	Data from an external provider	Chapter 12, "Business Directory (Yellow Pages) Support"

14.2 OpenLS Application Programming Interfaces

Two application programming interfaces (APIs) are provided using Spatial OpenLS services: a Web services API and a PL/SQL API.

The Web services API uses the same SOAP envelope as Web feature services (described in [Chapter 15](#)). You enable authentication and authorization using WSS and proxy authentication and user management.

The PL/SQL API is a convenient alternative to Web services. Authentication and authorization are enabled through the database connection that you use to call a PL/SQL subprogram to submit an OpenLS request and return the result. The PL/SQL API is implemented in the SDO_OLS package, which is documented in [Chapter 27](#).

14.3 OpenLS Service Support and Examples

This section describes the support provided for geocoding, mapping, routing, and directory service (YP). It also contains examples of OpenLS Web services API requests and responses.

14.3.1 OpenLS Geocoding

An OpenLS geocoding `<Request>` element includes the `methodName` attribute with a value of either `GeocodeRequest` or `ReverseGeocodeRequest`, and corresponding a top-level element named `<GeocodeRequest>` or `<ReverseGeocodeRequest>`.

If the `methodName` attribute value is `GeocodeRequest`, the `<GeocodeRequest>` element contains an `<Address>` element that can specify a free-form address, a street address, or an intersection address, with zero or more `<Place>` elements and an optional `<PostalCode>` element. The `<Address>` element has the required attribute `countryCode`, and several optional attributes.

If the `methodName` attribute value is `ReverseGeocodeRequest`, the `<ReverseGeocodeRequest>` element contains a `<Position>` element for identifying the location to be reverse geocoded, and an optional `<ReverseGeocodePreference>` element for specifying the information to be returned (default = a street address).

[Example 14–1](#) is a request to geocode two addresses in San Francisco, California.

Example 14–1 OpenLS Geocoding Request

```
<XLS
  xmlns=http://www.opengis.net/xls
  xmlns:gml=http://www.opengis.net/gml
  xmlns:xsi=http://www.w3.org/2001/XMLSchema-instance
  xsi:schemaLocation="http://www.opengis.net/xls ..."
  version="1.0">
  <RequestHeader clientName="someName" clientPassword="password"/>
```

```

<Request
  maximumResponses="10"
  methodName="GeocodeRequest"
  requestID="123"
  version="1.0">
  <GeocodeRequest>
    <Address countryCode="US">
      <StreetAddress>
        <Building number="400"/>
        <Street>Post Street</Street>
      </StreetAddress>
      <Place type="CountrySubdivision">CA</Place>
      <Place type="Municipality">San Francisco</Place>
      <PostalCode>94102</PostalCode>
    </Address>
    <Address countryCode="US">
      <StreetAddress>
        <Building number="233"/>
        <Street>Winston Drive</Street>
      </StreetAddress>
      <Place type="CountrySubdivision">CA</Place>
      <Place type="Municipality">San Francisco</Place>
      <PostalCode>94132</PostalCode>
    </Address>
  </GeocodeRequest>
</Request>
</XLS>

```

Example 14-2 is the response to the request in **Example 14-1**. The longitude and latitude coordinates are returned for the two addresses (-122.4083257 37.788208 for the first, -122.4753965 37.7269066 for the second).

Example 14-2 OpenLS Geocoding Response

```

<xls:XLS
  xmlns:xls=http://www.opengis.net/xls
  xmlns:gml=http://www.opengis.net/gml
  xmlns:xsi=http://www.w3.org/2001/XMLSchema-instance
  version="1.0">
  <xls:ResponseHeader/>
  <xls:Response requestID="123" version="1.0">
    <xls:GeocodeResponse xmlns:xls="http://www.opengis.net/xls">
      <xls:GeocodeResponseList
        xmlns:xls=http://www.opengis.net/xls
        numberOfGeocodedAddresses="1">
        <xls:GeocodedAddress>
          <gml:Point xmlns:gml="http://www.opengis.net/gml">
            <gml:pos dimension="2" srsName="4326">-122.4083257 37.788208</gml:pos>
          </gml:Point>
          <xls:Address countryCode="US">
            <xls:StreetAddress>
              <xls:Building number="400"/>
              <xls:Street>POST ST</xls:Street>
            </xls:StreetAddress>
            <xls:Place type="CountrySubdivision">CA</xls:Place>
            <xls:Place type="Municipality">SAN FRANCISCO</xls:Place>
            <xls:PostalCode>94102</xls:PostalCode>
          </xls:Address>
        </xls:GeocodedAddress>
      </xls:GeocodeResponseList>

```

```

<xls:GeocodeResponseList
  xmlns:xls=http://www.opengis.net/xls
  numberOfGeocodedAddresses="1">
  <xls:GeocodedAddress>
    <gml:Point xmlns:gml="http://www.opengis.net/gml">
      <gml:pos dimension="2" srsName="4326">-122.4753965 37.7269066</gml:pos>
    </gml:Point>
    <xls:Address countryCode="US">
      <xls:StreetAddress>
        <xls:Building number="233"/>
        <xls:Street>WINSTON DR</xls:Street>
      </xls:StreetAddress>
      <xls:Place type="CountrySubdivision">CA</xls:Place>
      <xls:Place type="Municipality">SAN FRANCISCO</xls:Place>
      <xls:PostalCode>94132</xls:PostalCode>
    </xls:Address>
  </xls:GeocodedAddress>
</xls:GeocodeResponseList>
</xls:GeocodeResponse>
</xls:Response>
</xls:XLS>

```

14.3.2 OpenLS Mapping

An OpenLS mapping `<Request>` element includes the `methodName` attribute with a value of `PortrayMapRequest`, and a top-level element named `<PortrayMapRequest>`.

The `<PortrayMapRequest>` element contains an `<Output>` element that specifies the output of the map to be generated, including the center point of the map.

The `<PortrayMapRequest>` element can contain a `<Basemap>` element specifying a MapViewer base map and one or more themes, and zero or more `<Overlay>` elements, each specifying information to be overlaid on the base map.

Example 14-3 is a request to portray a map image. The image is to be centered at a specified longitude/latitude point, to use a base map and two MapViewer themes, and identify three points on the map.

Example 14-3 OpenLS Mapping Request

```

<XLS
  xmlns=http://www.opengis.net/xls
  xmlns:gml=http://www.opengis.net/gml
  xmlns:xsi=http://www.w3.org/2001/XMLSchema-instance
  xsi:schemaLocation="http://www.opengis.net/xls ..."
  version="1.1">
  <RequestHeader clientName="someName" clientPassword="password"/>
  <Request
    maximumResponses="1"
    methodName="PortrayMapRequest"
    requestID="456"
    version="1.1">
    <PortrayMapRequest>
      <Output
        BGcolor="#a6cae0"
        content="URL"
        format="GIF_URL"
        height="600"
        transparent="false"
        width="800">

```

```

<CenterContext SRS="8307">
  <CenterPoint srsName="8307">
    <gml:pos>-122.2615 37.5266</gml:pos>
  </CenterPoint>
  <Radius unit="M">50000</Radius>
</CenterContext>
</Output>
<Basemap filter="Include">
  <Layer name="mvdemo.demo_map.THEME_DEMO_COUNTIES"/>
  <Layer name="mvdemo.demo_map.THEME_DEMO_HIGHWAYS"/>
</Basemap>
<Overlay zorder="1">
  <POI
    ID="123"
    description="description"
    phoneNumber="1234"
    POIName="Books at Post Str (point)">
    <gml:Point srsName="4326">
      <gml:pos>-122.4083257 37.788208</gml:pos>
    </gml:Point>
  </POI>
</Overlay>
<Overlay zorder="2">
  <POI
    ID="456"
    description="description"
    phoneNumber="1234"
    POIName="Books at Winston Dr (address)">
    <Address countryCode="US">
      <StreetAddress>
        <Building number="233"/>
        <Street>Winston Drive</Street>
      </StreetAddress>
      <Place type="CountrySubdivision">CA</Place>
      <Place type="CountrySecondarySubdivision"/>
      <Place type="Municipality">San Francisco</Place>
      <Place type="MunicipalitySubdivision"/>
      <PostalCode>94132</PostalCode>
    </Address>
  </POI>
</Overlay>
<Overlay zorder="3">
  <Position levelOfConf="1">
    <gml:Point gid="a boat (point)" srsName="4326">
      <gml:pos>-122.8053965 37.388208</gml:pos>
    </gml:Point>
  </Position>
</Overlay>
</PortrayMapRequest>
</Request>
</XLS>

```

Example 14-4 is the response to the request in **Example 14-3**.; however, in an actual response, the line `<xls:URL>Actual URL` replaced with constant string for `test</xls:URL>` would contain the actual URL of the map image.

Example 14-4 OpenLS Mapping Response

```

<xls:XLS
  xmlns:xls=http://www.opengis.net/xls

```

```

xmlns:gml=http://www.opengis.net/gml
xmlns:xsi=http://www.w3.org/2001/XMLSchema-instance
xsi:schemaLocation="http://www.opengis.net/xls ..."
version="1.1">
<xls:ResponseHeader/>
<xls:Response numberOfResponses="1" requestID="456" version="1.1">
  <xls:PortrayMapResponse>
    <xls:Map>
      <xls:Content format="GIF_URL" height="600" width="800">
        <xls:URL>Actual URL replaced with constant string for test</xls:URL>
      </xls:Content>
      <xls:BBoxContext srsName="4326">
        <gml:pos>-122.86037685607968 37.07744235794024</gml:pos>
        <gml:pos>-121.66262314392031 37.97575764205976</gml:pos>
      </xls:BBoxContext>
    </xls:Map>
  </xls:PortrayMapResponse>
</xls:Response>
</xls:XLS>

```

14.3.3 OpenLS Routing

An OpenLS routing `<Request>` element includes the `methodName` attribute with a value of `DetermineRouteRequest`, and a top-level element named `<DetermineRouteRequest>`.

The `<DetermineRouteRequest>` element contains a `<RoutePlan>` element that specifies the route preference and points to be included (and optionally avoided) in the route, with at least the start and end points.

The `<DetermineRouteRequest>` element can also contain zero or more of the following elements: `<RouteGeometryRequest>` to return the line string geometry representing the route, `<RouteMapRequest>` to request a map image of the route, and `<RouteInstructionsRequest>` to request driving directions for the route.

[Example 14-5](#) is a request for the route geometry and map image for the fastest route between an address in Cambridge, Massachusetts and an address in Nashua, New Hampshire.

Example 14-5 OpenLS Routing Request

```

<XLS
  xmlns=http://www.opengis.net/xls
  xmlns:gml=http://www.opengis.net/gml
  xmlns:xsi=http://www.w3.org/2001/XMLSchema-instance
  xsi:schemaLocation="http://www.opengis.net/xls ..."
  version="1.1">
  <RequestHeader clientName="someName" clientPassword="password" />
  <Request
    maximumResponses="10"
    methodName="DetermineRouteRequest"
    requestID="12345"
    version="1.0">
    <DetermineRouteRequest>
      <RoutePlan>
        <RoutePreference>Fastest</RoutePreference>
        <WayPointList>
          <StartPoint>
            <POI description="Borders" ID="1" phoneNumber="12345" POIName="Borders">
              <Address countryCode="US">

```

```

        <StreetAddress>
            <Building number="100"/>
            <Street>Cambridgeside Pl</Street>
        </StreetAddress>
        <Place type="CountrySubdivision">MA</Place>
        <Place type="Municipality">Cambridge</Place>
        <PostalCode>02141</PostalCode>
    </Address>
</POI>
</StartPoint>
<EndPoint>
    <Address countryCode="US">
        <StreetAddress>
            <Building number="1"/>
            <Street>Oracle Dr</Street>
        </StreetAddress>
        <Place type="CountrySubdivision">New Hampshire</Place>
        <Place type="Municipality">Nashua</Place>
        <PostalCode>03062</PostalCode>
    </Address>
</EndPoint>
</WayPointList>
<AvoidList/>
</RoutePlan>
<RouteGeometryRequest maxPoints="100" provideStartingPortion="true" scale="1">
    <BoundingBox>
        <gml:pos/>
        <gml:pos/>
    </BoundingBox>
</RouteGeometryRequest>
<RouteMapRequest>
    <Output BGcolor="" format="" height="600" transparent="false" width="800"/>
</RouteMapRequest>
</DetermineRouteRequest>
</Request>
</XLS>

```

Example 14–6 is part of the response to the request in **Example 14–5**. **Example 14–6** shows the total estimated driving time, the total distance, the lower-left and upper-right longitude/latitude coordinates of the minimum bounding rectangle that encloses the route, and the longitude/latitude coordinates of the first few points along the line geometry representing the route.

Example 14–6 OpenLS Routing Response

```

<xls:XLS
  xmlns:xls=http://www.opengis.net/xls
  xmlns:gml=http://www.opengis.net/gml
  xmlns:xsi=http://www.w3.org/2001/XMLSchema-instance
  xsi:schemaLocation="http://www.opengis.net/xls ..."
  version="1.1">
  <xls:ResponseHeader/>
  <xls:Response numberOfResponses="1" requestID="12345" version="1.0">
    <xls:DetermineRouteResponse>
      <xls:RouteSummary>
        <xls:TotalTime>P0DT0H42M26S</xls:TotalTime>
        <xls:TotalDistance uom="M" value="61528.7"/>
        <xls:BoundingBox srsName="4326">
          <gml:pos dimension="2" srsName="4326">-71.45937289088023 42.36694</gml:pos>
          <gml:pos dimension="2" srsName="4326">-71.06754 42.70824</gml:pos>

```

```

    </xls:BoundingBox>
  </xls:RouteSummary>
<xls:RouteGeometry>
  <gml:LineString srsName="4326">
    <gml:pos
      xmlns:gml=http://www.opengis.net/gml
      dimension="2"
      srsName="4326">-71.07444,42.36792</gml:pos>
    <gml:pos
      xmlns:gml=http://www.opengis.net/gml
      dimension="2"
      srsName="4326">-71.07162,42.37082</gml:pos>
    <gml:pos
      xmlns:gml=http://www.opengis.net/gml
      dimension="2"
      srsName="4326">-71.06954,42.37333</gml:pos>
  </gml:LineString>
</xls:RouteGeometry>

```

14.3.4 OpenLS Directory Service (YP)

An OpenLS directory service `<Request>` element includes the `methodName` attribute with a value of `DirectoryRequest`, and a top-level element named `<DirectoryRequest>`.

The `<DirectoryRequest>` element contains a `<POILocation>` element that specifies the location of a point of interest, that is, the center point from which to compute distances of returned businesses.

The `<DirectoryRequest>` element also contains a `<POIProperties>` element that specifies one or more `<POIProperty>` elements, each of which contains a `name` attribute identifying a property and a `value` attribute identifying the value for the property. The `name` attribute can specify any of the following strings: `ID`, `POIName`, `PhoneNumber`, `Keyword`, `NAICS_type`, `NAICS_subType`, `NAICS_category`, `SIC_type`, `SIC_subType`, `SIC_category`, `SIC_code`, or other.

[Example 14-7](#) is a request for information about business that have either or both of two specified SIC (Standard Industrial Classification) codes. For this example, the two SIC codes (1234567890 and 1234567891) are fictitious, and they are being used with a limited test data set in which these codes have been applied to categories (*Book stores* and *Cafes & Cafeterias*) that do not have these SIC codes in the real world.

Example 14-7 OpenLS Directory Service (YP) Request

```

<XLS
  xmlns=http://www.opengis.net/xls
  xmlns:gml=http://www.opengis.net/gml
  xmlns:xsi=http://www.w3.org/2001/XMLSchema-instance
  xsi:schemaLocation="http://www.opengis.net/xls ..."
  version="1.0">
  <RequestHeader clientName="someName" clientPassword="password"/>
  <Request
    requestID="123"
    maximumResponses="100"
    version="1.1"
    methodName="DirectoryRequest">
    <DirectoryRequest>
      <POILocation>
        <Address countryCode="US">
          </Address>
        </POILocation>

```



```

        <POIProperties>
            <POIProperty name="SIC_code" value="1234567890"/>
            <POIProperty name="SIC_code" value="1234567891"/>
        </POIProperties>
    </DirectoryRequest>
</Request>
</XLS>

```

[Example 14-8](#) is the response to the request in [Example 14-7](#). The response contains information about two businesses for which either or both of the specific SIC codes apply.

Example 14-8 OpenLS Directory Service (YP) Response

```

<xls:XLS
  xmlns:xls=http://www.opengis.net/xls
  xmlns:gml=http://www.opengis.net/gml
  xmlns:xsi=http://www.w3.org/2001/XMLSchema-instance
  version="1.0">
  <xls:ResponseHeader/>
  <xls:Response requestID="123" version="1.1">
    <DirectoryResponse xmlns="http://www.opengis.net/xls">
      <xls:POIContext xmlns:xls="http://www.opengis.net/xls">
        <xls:POI
          ID="1"
          POIName="Borders Books & More"
          phoneNumber="415-731-0665"
          description="Books & more">
          <POIAttributeList xmlns="http://www.opengis.net/xls">
            <xls:SIC
              xmlns:xls=http://www.opengis.net/xls
              category="Book stores"
              code="1234567890"
              subType=""
              type="" />
            <xls:SIC
              xmlns:xls=http://www.opengis.net/xls
              category="Cafes & Cafeterias"
              code="1234567891"
              subType="" type="" />
          </POIAttributeList>
          <gml:Point xmlns:gml="http://www.opengis.net/gml">
            <gml:pos dimension="2" srsName="4326">-122.4753965 37.7269066</gml:pos>
          </gml:Point>
          <xls:Address countryCode="US">
            <xls:StreetAddress>
              <xls:Building number="233"/>
              <xls:Street>Winston Drive</xls:Street>
            </xls:StreetAddress>
            <xls:Place type="CountrySubdivision">CA</xls:Place>
            <xls:Place type="CountrySecondarySubdivision"/>
            <xls:Place type="Municipality">San Francisco</xls:Place>
            <xls:Place type="MunicipalitySubdivision"/>
            <xls:PostalCode>94132</xls:PostalCode>
          </xls:Address>
        </xls:POI>
      </xls:POIContext>
      <xls:POIContext xmlns:xls="http://www.opengis.net/xls">
        <xls:POI
          ID="2"

```

```
POIName="Borders Books & More"
phoneNumber="415-399-1633"
description="Books & more">
<POIAttributeList xmlns="http://www.opengis.net/xls">
  <xls:SIC
    xmlns:xls=http://www.opengis.net/xls
    category="Book stores"
    code="1234567890"
    subType=""
    type="" />
  <xls:SIC
    xmlns:xls=http://www.opengis.net/xls
    category="Cafes & Cafeterias"
    code="1234567891"
    subType=""
    type="" />
</POIAttributeList>
<gml:Point xmlns:gml="http://www.opengis.net/gml">
  <gml:pos dimension="2" srsName="4326">-122.4083257 37.788208</gml:pos>
</gml:Point>
<xls:Address countryCode="US">
  <xls:StreetIntersection>
    <xls:Street>Post St</xls:Street>
    <xls:IntersectingStreet>Powell St</xls:IntersectingStreet>
  </xls:StreetIntersection>
  <xls:Place type="CountrySubdivision">CA</xls:Place>
  <xls:Place type="CountrySecondarySubdivision"/>
  <xls:Place type="Municipality">San Francisco</xls:Place>
  <xls:Place type="MunicipalitySubdivision"/>
  <xls:PostalCode>94102</xls:PostalCode>
</xls:Address>
</xls:POI>
</xls:POIContext>
</DirectoryResponse>
</xls:Response>
</xls:XLS>
```

Web Feature Service (WFS) Support

This chapter describes Web Feature Service (WFS) support in Oracle Spatial. It includes the following major sections:

- [Section 15.1, "WFS Engine"](#)
- [Section 15.2, "Managing Feature Types"](#)
- [Section 15.3, "Request and Response XML Examples"](#)
- [Section 15.4, "Java API for WFS Administration"](#)
- [Section 15.5, "Using WFS with Oracle Workspace Manager"](#)

Note: Before you use WFS, be sure that you understand the concepts described in [Chapter 10, "Introduction to Spatial Web Services"](#), and that you have performed any necessary configuration work as described in that chapter.

If you have data from a previous release that was indexed using one or more SYS.XMLTABLEINDEX indexes, you must drop the associated indexes before the upgrade and re-create the indexes after the upgrade, as described in [Section A.2](#).

15.1 WFS Engine

This section describes the Web Feature Service engine, including its relationship to clients and to the database server. WFS is implemented as a Web service and can be deployed in a WebLogic Server, Oracle Application Server, or standalone Oracle Application Server Containers for J2EE (OC4J) environment.

WFS has a metadata layer, which stores in the database the metadata needed to reply to the WFS requests. The metadata includes spatial columns, which can be queried and processed using Oracle Spatial interfaces. The metadata also stores the association of nonspatial and spatial attributes of features, as well as the services that the Web Feature Service provides to its clients.

[Figure 15–1](#) shows the WFS architecture.

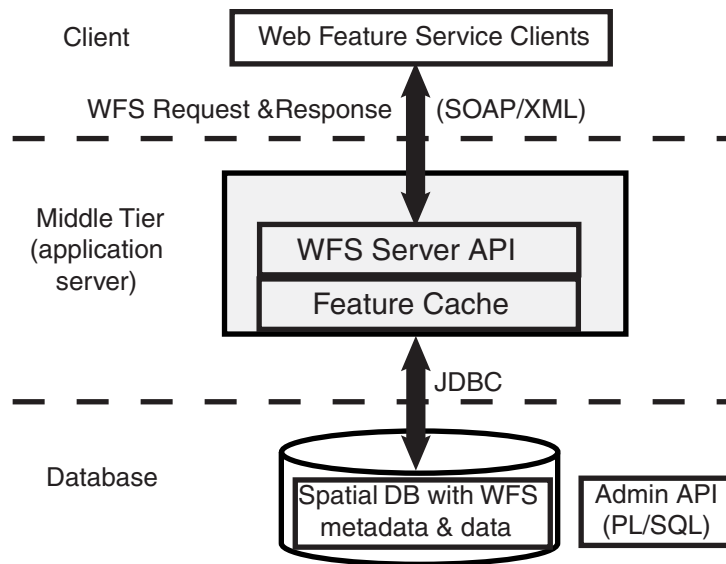
Figure 15–1 Web Feature Service Architecture

As shown in [Figure 15–1](#):

- WFS is part of the middle tier, and includes a WFS server API and a feature cache.
- WFS can communicate with a Web service client using WFS requests and responses in SOAP/XML format.
- WFS performs spatial data and metadata access through JDBC calls to the database.
- The database includes Oracle Spatial with WFS metadata and data, and with PL/SQL packages for administrative operations (see [Chapter 34, "SDO_WFS_PROCESS Package \(WFS Processing\)"](#) and [Chapter 33, "SDO_WFS_LOCK Package \(WFS\)"](#)).

Web Service Security (WSS) is implemented using secure transport. User identities and user labels are managed in LDAP, and the middle tier and WSS combine to perform authentication. Oracle label-based security is used for managing user privileges at the feature level. For more information about WSS, see [Chapter 17](#).

15.2 Managing Feature Types

WFS supports relational and document-based feature types:

- **Relational** feature types expose the content of database tables as feature instances. Relational feature types are well suited for those who use Oracle Spatial to manage their geospatial data and use Oracle Database to manage other business data. The Spatial WFS implementation provides ways to access the data, especially in service-oriented architecture (SOA) systems implemented using Web services.
Use PL/SQL application programming interfaces (APIs) to manage relational feature types. The PL/SQL packages `SDO_WFS_LOCK` and `SDO_WFS_PROCESS` (described in [Chapter 33](#) and [Chapter 34](#), respectively) enable you to manage relational feature types.
- **Document-based** feature types expose XML schema-based XML content as feature instances. Document-based feature types are well suited for those who use XML as their main data source and who might not currently use Oracle Spatial with such data. For this data, the Spatial WFS implementation extracts the geometry

components and stores them using the `SDO_GEOMETRY` type; it stores the remaining XML components in Oracle XDB and builds appropriate XMLIndex indexes for them.

Use Java APIs (described in [Section 15.4](#)) to manage document-based feature types.

These APIs enable you to perform operations that include:

- Publishing feature types
- Dropping (unpublishing) feature types
- Granting to users and revoking from users privileges of WFS metadata and feature types
- For relational feature types: lock-enabling and lock-disabling feature tables (with lock-enabling on by default for document-based feature types)

15.2.1 Capabilities Documents

A capabilities document describes an instance of a capability. The document specifies a feature type (such as roads or rivers) and the type of operations supported (such as insert and delete).

A capabilities document is generated by the WFS server in response to a `GetCapabilities` request. The WFS server uses a capabilities template, and adds information about the feature type and operations to this template to create the capabilities document.

The client can use the HTTP GET method to access this capabilities document using either the SOAP interface or the XML interface:

- For the SOAP interface, use `oracle.spatial.ws.servlet.WFSServlet`, which can be accessed at an address in the following format:

```
http://machine-name:port/SpatialWS-SpatialWS-context-root/wfsservlet?request=GetCapabilities&service=WFS&version=1.0.0
```

- For the XML interface, use `oracle.spatial.ws.servlet.WFSXMLServlet`, which can be accessed at an address in the following format:

```
http://machine-name:port/SpatialWS-SpatialWS-context-root/xmlwfsservlet?request=GetCapabilities&service=WFS&version=1.0.0
```

In the preceding formats:

- *machine-name* is the name of the system where the application server or OC4J server is running.
- *port* is the port number where the application server or OC4J server is running.
- *SpatialWS-SpatialWS-context-root* is the default root where the Spatial Web services application is mounted.
- *wfsservlet* is the servlet-mapping url-pattern for `oracle.spatial.ws.servlet.WFSServlet`, as specified by default in the `web.xml` file.
- *xmlwfsservlet* is the servlet-mapping url-pattern for `oracle.spatial.ws.servlet.WFSXMLServlet`, as specified by default in the `web.xml` file.

15.3 Request and Response XML Examples

This section presents some feature requests to the WFS engine, and the response to each request, for each of the following operations:

- GetCapabilities
- DescribeFeatureType
- GetFeature
- GetFeatureWithLock
- LockFeature
- Transaction, with a subelement specifying the transaction type:
 - Insert
 - Update
 - Delete

The XML request and response formats are similar for both relational and document-based features. Several examples in this section refer to relational features based on the COLA_MARKETS_CS table used in [Example 6–17](#) in [Section 6.13](#), where the MKT_ID column contains the unique numeric ID of each feature, the NAME column contains each feature's name (cola_a, cola_b, cola_c, or cola_d), and the SHAPE column contains the geometry associated with each feature.

[Example 15–1](#) is a request to get the capabilities of the WFS server named WFS at a specified namespace URL. This request will return a capabilities document, as explained in [Section 15.2.1](#)

Example 15–1 GetCapabilities Request

```
<?xml version="1.0" ?>
<GetCapabilities
  service="WFS"
  version="1.0.0"
  xmlns="http://www.opengis.net/wfs" />
```

[Example 15–2](#) is an excerpt of the response from the request in [Example 15–1](#).

Example 15–2 GetCapabilities Response

```
<WFS_Capabilities xmlns="http://www.opengis.net/wfs" version="1.0.0"
xmlns:ogc="http://www.opengis.net/ogc" xmlns:myns="http://www.example.com/myns">
  <Service>
    <Name> Oracle WFS </Name>
    <Title> Oracle Web Feature Service </Title>
    <Abstract> Web Feature Service maintained by Oracle </Abstract>

    <OnlineResource>http://localhost:8888/SpatialWS-SpatialWS-context-root/wfsservlet<
/OnlineResource>
  </Service>
  <Capability>
    <Request>
      <GetCapabilities>
        <DCPType>
          <HTTP>
            <Get
onlineResource="http://localhost:8888/SpatialWS-SpatialWS-context-root/wfsservlet"
/>
```

```

        </HTTP>
        </DCPType>
        <DCPType>
        <HTTP>
        <Post
onlineResource="http://localhost:8888/SpatialWS-SpatialWS-context-root/SpatialWSSo
apHttpPort"/>
        </HTTP>
        </DCPType>
        </GetCapabilities>
        <DescribeFeatureType>
        <SchemaDescriptionLanguage>
        <XMLSCHEMA/>
        </SchemaDescriptionLanguage>
        <DCPType>
        <HTTP>
        <Post
onlineResource="http://localhost:8888/SpatialWS-SpatialWS-context-root/SpatialWSSo
apHttpPort"/>
        </HTTP>
        </DCPType>
        </DescribeFeatureType>
        <GetFeature>
        <ResultFormat>
        <GML2/>
        </ResultFormat>
        <DCPType>
        <HTTP>
        <Post
onlineResource="http://localhost:8888/SpatialWS-SpatialWS-context-root/SpatialWSSo
apHttpPort"/>
        </HTTP>
        </DCPType>
        </GetFeature>
        <GetFeatureWithLock>
        <ResultFormat>
        <GML2/>
        </ResultFormat>
        <DCPType>
        <HTTP>
        <Post
onlineResource="http://localhost:8888/SpatialWS-SpatialWS-context-root/SpatialWSSo
apHttpPort"/>
        </HTTP>
        </DCPType>
        </GetFeatureWithLock>
        <Transaction>
        <DCPType>
        <HTTP>
        <Post
onlineResource="http://localhost:8888/SpatialWS-SpatialWS-context-root/SpatialWSSo
apHttpPort"/>
        </HTTP>
        </DCPType>
        </Transaction>
        <LockFeature>
        <DCPType>
        <HTTP>
        <Post
onlineResource="http://localhost:8888/SpatialWS-SpatialWS-context-root/SpatialWSSo

```

```

apHttpPort"/>
    </HTTP>
    </DCPType>
    </LockFeature>
</Request>
</Capability>
<FeatureTypeList>
    <Operations>
        <Insert/>
        <Update/>
        <Delete/>
        <Query/>
        <Lock/>
    </Operations>
    <FeatureType xmlns:myns="http://www.example.com/myns">
    <Name> myns:COLA</Name>
    <Title> LIST OF COLA MARKETS </Title>
    <SRS> SDO:8307</SRS>
</FeatureType><FeatureType xmlns:myns="http://www.example.com/myns">
    <Name> myns:COLAVIEW1 </Name>
    <Title> LIST OF COLA MARKET VIEW </Title>
    <SRS> SDO:8307</SRS>
</FeatureType><FeatureType xmlns:wfs="http://www.opengis.net/wfs">
    <Name xmlns:myns="http://www.example.com/myns1">myns:SampleFeature</Name>
    <Title>SAMPLE FEATURE</Title>
    <SRS>EPSG:32615</SRS>
</FeatureType></FeatureTypeList>
    <ogc:Filter_Capabilities xmlns:ogc="http://www.opengis.net/ogc">
        <ogc:Spatial_Capabilities>
            <ogc:Spatial_Operators>
                <ogc:BBOX/>
                <ogc:Equals/>
                <ogc:Disjoint/>
                <ogc:Intersect/>
                <ogc:Touches/>
                <ogc:Crosses/>
                <ogc:Within/>
                <ogc:Contains/>
                <ogc:Overlaps/>
                <ogc:Beyond/>
                <ogc:DWithin/>
            </ogc:Spatial_Operators>
        </ogc:Spatial_Capabilities>
        <ogc:Scalar_Capabilities>
            <ogc:Logical_Operators/>
            <ogc:Comparison_Operators>
                <ogc:Simple_Comparisons/>
                <ogc:Like/>
                <ogc:Between/>
                <ogc:NullCheck/>
            </ogc:Comparison_Operators>
            <ogc:Arithmetic_Operators>
                <ogc:Simple_Arithmetic/>
            </ogc:Arithmetic_Operators>
        </ogc:Scalar_Capabilities>
    </ogc:Filter_Capabilities>
</WFS_Capabilities>

```

[Example 15-3](#) is a request to describe the feature type named COLA.

Example 15-3 DescribeFeatureType Request

```
<?xml version="1.0" ?>
<wfs:DescribeFeatureType
  service="WFS"
  version="1.0.0"
  xmlns:wfs="http://www.opengis.net/wfs"
  xmlns:myns="http://www.example.com/myns"
  xmlns:xsi="http://www.w3.org/2001/XMLSchema-instance"
  xmlns:xsd="http://www.w3.org/2001/XMLSchema"
  xsi:schemaLocation="http://www.opengis.net/wfs ../wfs/1.0.0/WFS-basic.xsd">
  <wfs:TypeName>myns:COLA</wfs:TypeName>
</wfs:DescribeFeatureType>
```

[Example 15-4](#) is the response from the request in [Example 15-3](#). The response is an XML schema definition (XSD).

Example 15-4 DescribeFeatureType Response

```
<xsd:schema targetNamespace="http://www.example.com/myns"
  xmlns:wfs="http://www.opengis.net/wfs" xmlns:myns="http://www.example.com/myns"
  xmlns:gml="http://www.opengis.net/gml" elementFormDefault="qualified"
  version="1.0.0" xmlns:xsd="http://www.w3.org/2001/XMLSchema">
  <xsd:import namespace="http://www.opengis.net/gml"
  schemaLocation="http://localhost:8888/examples/servlets/xsds/feature.xsd"/>
  <xsd:element name="COLA" type="myns:COLAType" substitutionGroup="gml:_
  Feature"/>
  <xsd:complexType name="COLAType">
    <xsd:complexContent>
      <xsd:extension base="gml:AbstractFeatureType">
        <xsd:sequence>
          <xsd:element name="MKT_ID" type="xsd:double"/>
          <xsd:element name="NAME" nillable="true">
            <xsd:simpleType>
              <xsd:restriction base="xsd:string">
                <xsd:maxLength value="32"/>
              </xsd:restriction>
            </xsd:simpleType>
          </xsd:element>
          <xsd:element name="SHAPE" type="gml:PolygonMemberType"
  nillable="true"/>
        </xsd:sequence>
        <xsd:attribute name="fid" type="xsd:double"/>
      </xsd:extension>
    </xsd:complexContent>
  </xsd:complexType>
</xsd:schema>
```

[Example 15-5](#) is a request to get the MKT_ID, NAME, and SHAPE properties of the feature or features of type COLA where the MKT_ID value is greater than 2 and the NAME value is equal to cola_c, or where the MKT_ID value is greater than 3 and the NAME value is equal to cola_d.

Note: For `GetFeature` and `GetFeatureWithLock`, the `<Query>` and `<PropertyName>` elements, which list the property names to be selected, can be any top-level element of the queried feature type, in which case its entire content (which may be nested) is returned in the query response. XPath's of arbitrary depth are not supported in `<PropertyName>` elements directly under the `<Query>` element; however, they are supported in `<PropertyName>` elements in a `<Filter>` element under the `<Query>` element, as shown in [Example 15-5](#) and [Example 15-7](#).

Example 15-5 *GetFeature Request*

```
<?xml version="1.0" ?>
<wfs:GetFeature
  service="WFS"
  version="1.0.0"
  xmlns:wfs="http://www.opengis.net/wfs"
  xmlns:ogc="http://www.opengis.net/ogc"
  xmlns:myns="http://www.example.com/myns"
  xmlns:xsi="http://www.w3.org/2001/XMLSchema-instance"
  xsi:schemaLocation="http://www.opengis.net/wfs ../wfs/1.0.0/WFS-basic.xsd">
  <wfs:Query typeName="myns:COLA">
    <ogc:PropertyName>myns:MKT_ID</ogc:PropertyName>
    <ogc:PropertyName>myns:NAME</ogc:PropertyName>
    <ogc:PropertyName>myns:SHAPE</ogc:PropertyName>
    <ogc:Filter>
      <ogc:And>
        <ogc:And>
          <ogc:PropertyIsGreaterThan>
            <ogc:PropertyName>myns:COLA/myns:MKT_ID</ogc:PropertyName>
            <ogc:Literal> 2 </ogc:Literal>
          </ogc:PropertyIsGreaterThan>
          <ogc:PropertyIsEqualTo>
            <ogc:PropertyName>myns:COLA/myns:NAME</ogc:PropertyName>
            <ogc:Literal>cola_c</ogc:Literal>
          </ogc:PropertyIsEqualTo>
        </ogc:And>
        <ogc:Or>
          <ogc:PropertyIsEqualTo>
            <ogc:PropertyName>myns:COLA/myns:MKT_ID</ogc:PropertyName>
            <ogc:Literal>3</ogc:Literal>
          </ogc:PropertyIsEqualTo>
          <ogc:PropertyIsEqualTo>
            <ogc:PropertyName>myns:COLA/myns:NAME</ogc:PropertyName>
            <ogc:Literal>cola_d</ogc:Literal>
          </ogc:PropertyIsEqualTo>
        </ogc:Or>
      </ogc:And>
    </ogc:Filter>
  </wfs:Query>
</wfs:GetFeature>
```

[Example 15-6](#) is the response from the request in [Example 15-5](#).

Example 15-6 *GetFeature Response*

```
<?xml version = '1.0' encoding = 'UTF-8'?>
<wfs:FeatureCollection xsi:schemaLocation="http://www.example.com/myns
```

```

http://localhost:8888/wfsservlet?featureTypeId=1 http://www.opengis.net/wfs
../wfs/1.0.0/WFS-basic.xsd xmlns:wfs="http://www.opengis.net/wfs"
xmlns:xsi="http://www.w3.org/2001/XMLSchema-instance">
  <gml:boundedBy xmlns:gml="http://www.opengis.net/gml">
    <gml:Box srsName="SDO:8307">
      <gml:coordinates>3.0,3.0 6.0,5.0</gml:coordinates>
    </gml:Box>
  </gml:boundedBy>
  <gml:featureMember xmlns:gml="http://www.opengis.net/gml">
    <myns:COLA fid="3" xmlns:myns="http://www.example.com/myns">
      <myns:MKT_ID>3</myns:MKT_ID>
      <myns:NAME>cola_c</myns:NAME>
      <myns:SHAPE>
        <gml:Polygon srsName="SDO:8307"
xmlns:gml="http://www.opengis.net/gml">
          <gml:outerBoundaryIs>
            <gml:LinearRing>
              <gml:coordinates decimal="." cs="," ts=" ">3.0,3.0 6.0,3.0
6.0,5.0 4.0,5.0 3.0,3.0 </gml:coordinates>
            </gml:LinearRing>
          </gml:outerBoundaryIs>
        </gml:Polygon>
      </myns:SHAPE>
    </myns:COLA>
  </gml:featureMember>
</wfs:FeatureCollection>

```

[Example 15-7](#) is a request to get the MKT_ID, NAME, and SHAPE properties of the feature of type COLA where the MKT_ID value is greater than 2 and the NAME value is equal to cola_c, or where the MKT_ID value is equal to 3, and to lock that feature.

Example 15-7 GetFeatureWithLock Request

```

<?xml version="1.0" ?>
<wfs:GetFeatureWithLock
  service="WFS"
  version="1.0.0"
  expiry="5"
  xmlns:wfs="http://www.opengis.net/wfs"
  xmlns:ogc="http://www.opengis.net/ogc"
  xmlns:gml="http://www.opengis.net/gml"
  xmlns:myns="http://www.example.com/myns"
  xmlns:xsi="http://www.w3.org/2001/XMLSchema-instance" >
  <wfs:Query typeName="myns:COLA">
    <ogc:PropertyName>myns:MKT_ID</ogc:PropertyName>
    <ogc:PropertyName>myns:NAME</ogc:PropertyName>
    <ogc:PropertyName>myns:SHAPE</ogc:PropertyName>
    <ogc:Filter>
      <ogc:PropertyIsEqualTo>
        <ogc:PropertyName>myns:COLA/myns:MKT_ID</ogc:PropertyName>
        <ogc:Literal> 3 </ogc:Literal>
      </ogc:PropertyIsEqualTo>
    </ogc:Filter>
  </wfs:Query>
</wfs:GetFeatureWithLock>

```

[Example 15-8](#) is the response from the request in [Example 15-7](#).

Example 15-8 GetFeatureWithLock Response

```

<wfs:FeatureCollection xmlns:wfs="http://www.opengis.net/wfs" lockId="1"
  xsi:schemaLocation="http://www.example.com/myns
http://localhost:8888/SpatialWS-SpatialWS-context-root/wfsservlet?featureTypeId=1"
  xmlns:xsi="http://www.w3.org/2001/XMLSchema-instance">
  <gml:boundedBy xmlns:gml="http://www.opengis.net/gml">
    <gml:Box srsName="SDO:8307">
      <gml:coordinates>3.0,3.0 6.0,5.0</gml:coordinates>
    </gml:Box>
  </gml:boundedBy>
  <gml:featureMember xmlns:gml="http://www.opengis.net/gml">
    <myns:COLA xmlns:myns="http://www.example.com/myns" fid="3">
      <myns:MKT_ID>3</myns:MKT_ID>
      <myns:NAME>cola_c</myns:NAME>
      <myns:SHAPE>
        <gml:Polygon srsName="SDO:8307">
          <gml:outerBoundaryIs>
            <gml:LinearRing>
              <gml:coordinates decimal="." cs="," ts=" ">3.0,3.0 6.0,3.0
6.0,5.0 4.0,5.0 3.0,3.0 </gml:coordinates>
            </gml:LinearRing>
          </gml:outerBoundaryIs>
        </gml:Polygon>
      </myns:SHAPE>
    </myns:COLA>
  </gml:featureMember>
</wfs:FeatureCollection>

```

[Example 15-9](#) is a request to lock the feature where the MKT_ID value is equal to 2.

Example 15-9 LockFeature Request

```

<?xml version="1.0" ?>
<wfs:LockFeature
  service="WFS"
  version="1.0.0"
  expiry="5"
  xmlns:wfs="http://www.opengis.net/wfs"
  xmlns:ogc="http://www.opengis.net/ogc"
  xmlns:gml="http://www.opengis.net/gml"
  xmlns:myns="http://www.example.com/myns"
  xmlns:xsi="http://www.w3.org/2001/XMLSchema-instance" >
  <wfs:Lock typeName="myns:COLA">
    <ogc:Filter>
      <ogc:PropertyIsEqualTo>
        <ogc:PropertyName>myns:COLA/myns:MKT_ID</ogc:PropertyName>
        <ogc:Literal> 2 </ogc:Literal>
      </ogc:PropertyIsEqualTo>
    </ogc:Filter>
  </wfs:Lock>
</wfs:LockFeature>

```

[Example 15-10](#) is the response from the request in [Example 15-9](#).

Example 15-10 LockFeature Response

```

<wfs:WFS_LockFeatureResponse xmlns:wfs="http://www.opengis.net/wfs">
  <wfs:LockId>2</wfs:LockId>
</wfs:WFS_LockFeatureResponse>

```

[Example 15–11](#) is a request to insert a feature, with `MKT_ID = 5` and `NAME = cola_e`, into the table associated with the WFS service named `WFS`.

Example 15–11 Insert Request

```
<?xml version="1.0"?>
<wfs:Transaction version="1.0.0" handle="TX01" service="WFS" xmlns="http://www.e
xample.com/myns" xmlns:myns="http://www.example.com/myns" xmlns:gml="http://ww
w.opengis.net/gml" xmlns:ogc="http://www.opengis.net/ogc" xmlns:wfs="http://www.
opengis.net/wfs" xmlns:xsi="http://www.w3.org/2001/XMLSchema-instance" >
<wfs:Insert handle="INSERT01" >
<myns:COLA fid="5" xmlns:myns="http://www.example.com/myns">
  <myns:MKT_ID>5</myns:MKT_ID>
  <myns:NAME>cola_e</myns:NAME>
  <myns:SHAPE>
    <gml:Polygon srsName="SDO:8307"
xmlns:gml="http://www.opengis.net/gml">
      <gml:outerBoundaryIs>
        <gml:LinearRing>
          <gml:coordinates decimal="." cs="," ts=" ">1.0,3.0 6.0,3.0
6.0,5.0 4.0,5.0 1.0,3.0 </gml:coordinates>
        </gml:LinearRing>
      </gml:outerBoundaryIs>
    </gml:Polygon>
  </myns:SHAPE>
</myns:COLA>
</wfs:Insert>
</wfs:Transaction>
```

[Example 15–12](#) is the response from the request in [Example 15–11](#).

Example 15–12 Insert Response

```
<?xml version = '1.0' encoding = 'UTF-8'?>
<wfs:WFS_TransactionResponse version="1.0.0"
xmlns:wfs="http://www.opengis.net/wfs">
  <wfs:InsertResult handle="INSERT01">
    <ogc:FeatureId fid="5" xmlns:ogc="http://www.opengis.net/ogc"/>
  </wfs:InsertResult>
  <wfs:TransactionResult handle="TX01">
    <wfs:Status>
      <wfs:SUCCESS/>
    </wfs:Status>
  </wfs:TransactionResult>
</wfs:WFS_TransactionResponse>
```

[Example 15–13](#) is a request to update the feature, where `MKT_ID` is greater than 2 and less than 4 and where `NAME` is not null, in the table associated with the WFS service named `WFS`. This request specifies that the `NAME` value of the specified feature is to be set to `cola_cl`.

Example 15–13 Update Request

```
<?xml version="1.0"?>
<wfs:Transaction version="1.0.0" handle="TX01" service="WFS"
xmlns="http://www.example.com/myns"
xmlns:myns="http://www.example.com/myns" xmlns:gml="http://www.opengis.net/gml"
xmlns:ogc="http://www.opengis.net/ogc" xmlns:wfs="http://www.
opengis.net/wfs" xmlns:xsi="http://www.w3.org/2001/XMLSchema-instance" >
<wfs:Update handle="UPDATE1" typeName="myns:COLA" >
```

```

<wfs:Property>
  <wfs:Name>myns:COLA/myns:NAME</wfs:Name>
  <wfs:Value>cola_c1</wfs:Value>
</wfs:Property>
<ogc:Filter>
  <ogc:And>
    <ogc:And>
      <ogc:PropertyIsGreaterThan>
        <ogc:PropertyName>myns:COLA/myns:MKT_ID</ogc:PropertyName>
        <ogc:Literal> 2 </ogc:Literal>
      </ogc:PropertyIsGreaterThan>
      <ogc:PropertyIsLessThan>
        <ogc:PropertyName>myns:COLA/myns:MKT_ID</ogc:PropertyName>
        <ogc:Literal> 4 </ogc:Literal>
      </ogc:PropertyIsLessThan>
    </ogc:And>
    <ogc:Not>
      <ogc:PropertyIsNull>
        <ogc:PropertyName>myns:COLA/myns:NAME</ogc:PropertyName>
      </ogc:PropertyIsNull>
    </ogc:Not>
  </ogc:And>
</ogc:Filter>
</wfs:Update>
</wfs:Transaction>

```

[Example 15–14](#) is the response from the request in [Example 15–13](#).

Example 15–14 Update Response

```

<?xml version = '1.0' encoding = 'UTF-8'?>
<wfs:WFS_TransactionResponse version="1.0.0"
xmlns:wfs="http://www.opengis.net/wfs">
  <wfs:TransactionResult handle="TX01">
    <wfs:Status>
      <wfs:SUCCESS/>
    </wfs:Status>
  </wfs:TransactionResult>
</wfs:WFS_TransactionResponse>

```

[Example 15–15](#) is a request to delete the feature, where MKT_ID is greater than 3 and NAME is equal to cola_e and is not null, in the table associated with the WFS service named WFS.

Example 15–15 Delete Request

```

<?xml version="1.0"?>
<wfs:Transaction version="1.0.0" handle="TX01" service="WFS"
xmlns="http://www.example.com/myns"
xmlns:myns="http://www.example.com/myns" xmlns:gml="http://www.opengis.net/gml"
xmlns:ogc="http://www.opengis.net/ogc" xmlns:wfs="http://www.
opengis.net/wfs" xmlns:xsi="http://www.w3.org/2001/XMLSchema-instance" >
<wfs>Delete handle="DELETE1" typeName="myns:COLA" >
<ogc:Filter>
  <ogc:And>
    <ogc:And>
      <ogc:PropertyIsGreaterThan>
        <ogc:PropertyName>myns:COLA/myns:MKT_ID</ogc:PropertyName>
        <ogc:Literal> 3 </ogc:Literal>
      </ogc:PropertyIsGreaterThan>

```

```

        <ogc:PropertyIsEqualTo>
            <ogc:PropertyName>myns:COLA/myns:NAME</ogc:PropertyName>
            <ogc:Literal> cola_e </ogc:Literal>
        </ogc:PropertyIsEqualTo>
    </ogc:And>
    <ogc:Not>
        <ogc:PropertyIsNull>
            <ogc:PropertyName>myns:COLA/myns:NAME</ogc:PropertyName>
        </ogc:PropertyIsNull>
    </ogc:Not>
    </ogc:And>
</ogc:Filter>
</wfs:Delete>
</wfs:Transaction>

```

[Example 15–16](#) is the response from the request in [Example 15–15](#).

Example 15–16 Delete Response

```

<?xml version = '1.0' encoding = 'UTF-8'?>
<wfs:WFS_TransactionResponse version="1.0.0"
xmlns:wfs="http://www.opengis.net/wfs">
    <wfs:TransactionResult handle="TX01">
        <wfs:Status>
            <wfs:SUCCESS/>
        </wfs:Status>
    </wfs:TransactionResult>
</wfs:WFS_TransactionResponse>

```

15.4 Java API for WFS Administration

In addition to the PL/SQL APIs in the SDO_WFS_PROCESS and SDO_WFS_LOCK packages, you can use a Java API to publish and drop feature types, and to grant and revoke access to feature types and WFS metadata tables.

This section provides basic reference information about the methods in the `oracle.spatial.wfs.WFSAdmin` class. The methods are presented in alphabetical order.

15.4.1 createXMLTableIndex method

The `createXMLTableIndex` method creates an index of XDB.XMLINDEX on document-based feature type instances. This method has the following format:

```

public static void createXMLTableIndex(
    OracleConnection conn,
    String ftNSUrl,
    String ftName) throws SQLException;

```

`conn` is an Oracle Database connection for a user that has been granted the DBA role.

`ftNSUrl` is the URL of the namespace of the feature type.

`ftName` is the name of the feature type.

15.4.2 dropFeatureType method

The `dropFeatureType` method deletes a feature type from the WFS repository. This method has the following format:

```
public static void dropFeatureType(
    OracleConnection conn,
    String ftNSUrl,
    String ftName) throws SQLException;
```

`conn` is an Oracle Database connection for a user that has been granted the DBA role.

`ftNSUrl` is the URL of the namespace of the feature type.

`ftName` is the name of the feature type.

15.4.3 dropXMLTableIndex method

The `dropXMLTableIndex` method drops an index of type `XDB.XMLINDEX` that was created on document-based feature type instances. This method has the following format:

```
public static void dropXMLTableIndex(
    OracleConnection conn,
    String ftNSUrl,
    String ftName) throws SQLException;
```

`conn` is an Oracle Database connection for a user that has been granted the DBA role.

`ftNSUrl` is the URL of the namespace of the feature type.

`ftName` is the name of the feature type.

15.4.4 getIsXMLTableIndexCreated method

The `getIsXMLTableIndexCreated` method returns a Boolean `TRUE` if an index of type `XDB.XMLINDEX` has been created on a document-based feature type, or a Boolean `FALSE` if such an index has not been created. This method has the following format:

```
public static boolean getIsXMLTableIndexCreated(
    OracleConnection conn,
    String ftNSUrl,
    String ftName) throws SQLException;
```

`conn` is an Oracle Database connection for a user that has been granted the DBA role.

`ftNSUrl` is the URL of the namespace of the feature type.

`ftName` is the name of the feature type.

15.4.5 grantFeatureTypeToUser method

The `grantFeatureTypeToUser` method grants access to a feature type to a database user. This method has the following format:

```
public static void grantFeatureTypeToUser(
    OracleConnection conn,
    String typeNS,
    String typeName,
    String usrName) throws SQLException;
```

`conn` is an Oracle Database connection for a user that has been granted the DBA role.

`typeNS` is the URL of the namespace of the feature type.

`typeName` is the name of the feature type.

usrName is the name of the database user.

15.4.6 grantMDAccessToUser method

The `grantMDAccessToUser` method grants access to the WFS metadata to a database user. This method has the following format:

```
public static void grantMDAccessToUser(
    OracleConnection conn,
    String usrName) throws SQLException;
```

conn is an Oracle Database connection for a user that has been granted the DBA role.

usrName is the name of the database user.

15.4.7 publishFeatureType method

The `publishFeatureType` method publishes a document-based feature type; that is, it registers metadata related to the feature type. This method has the following formats:

```
public static void publishFeatureType(OracleConnection conn,
    XMLType featureTypeMD) throws SQLException , WFSException;
```

```
public static void publishFeatureType(OracleConnection conn,
    XMLType schemaDocXt,
    XMLType featureDescXt,
    ArrayList<String> docIdPaths,
    String primarySpatialPath,
    String featureMemberNS,
    String featureMemberName,
    String ftNSUrl,
    String ftName,
    ArrayList<PathInfo> spatialPaths,
    ArrayList<PathInfo> mandatoryPaths,
    ArrayList<PathInfo> tsPaths,
    ArrayList<GeomMetaInfo> sdoMetaInfo,
    String srsNS,
    String srsNSAlias) throws SQLException;
```

```
public static void publishFeatureType(OracleConnection conn,
    XMLType schemaDocXt,
    XMLType featureDescXt,
    ArrayList<String> docIdPaths,
    String primarySpatialPath,
    String featureMemberNS,
    String featureMemberName,
    String ftNSUrl,
    String ftName,
    ArrayList<PathInfo> spatialPaths,
    ArrayList<PathInfo> mandatoryPaths,
    ArrayList<PathInfo> tsPaths,
    ArrayList<GeomMetaInfo> sdoMetaInfo,
    String srsNS,
    String srsNSAlias,
    String ftXSDRefId) throws SQLException;
```

```
public static void publishFeatureType(OracleConnection conn,
    XMLType schemaDocXt,
    XMLType featureDescXt,
```

```
        ArrayList<String> docIdPaths,  
        String primarySpatialPath,  
        String featureMemberNS,  
        String featureMemberName,  
        String ftNSUrl,  
        String ftName,  
        ArrayList<PathInfo> spatialPaths,  
        ArrayList<PathInfo> mandatoryPaths,  
        ArrayList<PathInfo> tsPaths,  
        ArrayList<GeomMetaInfo> sdoMetaInfo,  
        String srsNS,  
        String srsNSAlias,  
        String ftXSDRefId,  
        boolean genSpatialIndex,  
        boolean lockEnable) throws SQLException;  
  
public static void publishFeatureType(OracleConnection conn,  
        XMLType schemaDocXt,  
        XMLType featureDescXt,  
        ArrayList<String> docIdPaths,  
        String primarySpatialPath,  
        String featureMemberNS,  
        String featureMemberName,  
        String ftNSUrl,  
        String ftName,  
        ArrayList<PathInfo> spatialPaths,  
        ArrayList<PathInfo> mandatoryPaths,  
        ArrayList<PathInfo> tsPaths,  
        ArrayList<GeomMetaInfo> sdoMetaInfo,  
        String srsNS,  
        String srsNSAlias,  
        String ftXSDRefId,  
        boolean genSpatialIndex,  
        boolean lockEnable,  
        ArrayList<PathInfo> numPaths,  
        ArrayList<PathInfo> idxPaths,  
        ArrayList<String[]> idxPathTypes,  
        boolean genXMLIndex) throws SQLException;  
  
public static void publishFeatureType(OracleConnection conn,  
        XMLType schemaDocXt,  
        XMLType featureDescXt,  
        ArrayList<String> docIdPaths,  
        String primarySpatialPath,  
        String featureMemberNS,  
        String featureMemberName,  
        String ftNSUrl,  
        String ftName,  
        ArrayList<PathInfo> spatialPaths,  
        ArrayList<PathInfo> mandatoryPaths,  
        ArrayList<PathInfo> tsPaths,  
        ArrayList<GeomMetaInfo> sdoMetaInfo,  
        String srsNS,  
        String srsNSAlias,  
        String ftXSDRefId,  
        boolean genSpatialIndex,  
        boolean lockEnable,  
        ArrayList<PathInfo> numPaths,  
        ArrayList<PathInfo> idxPaths,  
        ArrayList<String[]> idxPathTypes,
```

```
        boolean genXMLIndex,
        String featureCollectionNS,
        String featureCollectionName,
        boolean isGML3) throws SQLException;

public static void publishFeatureType(OracleConnection conn,
        XMLType schemaDocXt,
        XMLType featureDescXt,
        ArrayList<String> docIdPaths,
        String primarySpatialPath,
        String featureMemberNS,
        String featureMemberName,
        String ftNSUrl,
        String ftName,
        ArrayList<PathInfo> spatialPaths,
        ArrayList<PathInfo> mandatoryPaths,
        ArrayList<PathInfo> tsPaths,
        ArrayList<GeomMetaInfo> sdoMetaInfo,
        String srsNS,
        String srsNSAlias,
        String ftXSDRefId,
        boolean genSpatialIndex,
        boolean lockEnable,
        ArrayList<PathInfo> numPaths,
        ArrayList<PathInfo> idxPaths,
        ArrayList<String[]> idxPathTypes,
        boolean genXMLIndex,
        String featureCollectionNS,
        String featureCollectionName,
        boolean isGML3,
        CollectionPathInfo collPathInfo) throws SQLException;

public static void publishFeatureType(OracleConnection conn,
        XMLType schemaDocXt,
        XMLType featureDescXt,
        ArrayList<String> docIdPaths,
        String primarySpatialPath,
        String featureMemberNS,
        String featureMemberName,
        String ftNSUrl,
        String ftName,
        ArrayList<PathInfo> spatialPaths,
        ArrayList<PathInfo> mandatoryPaths,
        ArrayList<PathInfo> tsPaths,
        ArrayList<GeomMetaInfo> sdoMetaInfo,
        String srsNS,
        String srsNSAlias,
        String ftXSDRefId,
        boolean genSpatialIndex,
        boolean lockEnable,
        ArrayList<PathInfo> numPaths,
        ArrayList<PathInfo> idxPaths,
        ArrayList<String[]> idxPathTypes,
        boolean genXMLIndex,
        String featureCollectionNS,
        String featureCollectionName,
        boolean isGML3,
        CollectionPathInfo collPathInfo,
        boolean hasMultipleSRSNS) throws SQLException;
```

`conn` is an Oracle Database connection for a user that has been granted the DBA role.

`featureTypeMD` is the feature type path registration metadata. This metadata must conform to the `featureTypeMd` element definition as specified in the `wstype_md.xsd` file. An example of feature type path registration metadata XML is provided in `ft_metadata.xml`. These files are included in the `ws_client.jar` demo file (described in [Section 10.4](#)) under the `src/data/` path. For information about using the example to publish a feature type, see the `Readme.txt` file, which is included in `ws_client.jar` under the `src/` path.

`schemaDocXt` is the XML schema definition (XSD) of the feature type.

`featureDescXt` is the XML schema definition (XSD) of the feature type description, to be included in the `Capabilities` document.

`docIdPaths` is a list of document ID path elements where each element is a `String`.

`primarySpatialPath` is the primary spatial path that will be used to compute the bounding box in the result.

`featureMemberNS` is the namespace of the feature member.

`featureMemberName` is the name of the feature member.

`ftNSUrl` is the URL of the namespace of the feature type.

`ftName` is the name of the feature type.

`spatialPaths` is a list of spatial paths in the feature type. It is an `ArrayList` of class `oracle.spatial.ws.PathInfo`, which is described in [Section 15.4.7.1](#).

`mandatoryPaths` is a list of mandatory paths in the feature type. It is an `ArrayList` of class `oracle.spatial.ws.PathInfo`, which is described in [Section 15.4.7.1](#).

`tsPaths` is a list of time-related paths in the feature type (for example, `date`, `dateTime`, `gYear`, `gMonth`, `gDay`, `gMonthDay`, and `gYearMonth`). It is an `ArrayList` of class `oracle.spatial.ws.PathInfo`, which is described in [Section 15.4.7.1](#).

`sdoMetaInfo` is the spatial metadata information for spatial paths. It is an `ArrayList` of class `oracle.spatial.ws.GeomMetaInfo`, which is described in [Section 15.4.7.1](#).

`srsNS` is the user-defined namespace of the spatial reference system (coordinate system) associated with the data in the spatial paths. This namespace (if specified) is also used to generate the `srsName` attribute in the `<boundedBy>` element of the `FeatureCollection` result generated for the `GetFeature` request.

`srsNSAlias` is the namespace alias of the spatial reference system (coordinate system) associated with the data in the spatial paths.

`ftXSDRefId` is the group feature type XML schema definition file name (as a string), for cases where multiple feature types are defined in a single XSD file. This parameter is used to store the group XSD definition once in the WFS metadata, and then refer to it from multiple feature types whose schema definitions are present in the group feature type XSD file.

`genSpatialIndex` is a Boolean value: `TRUE` causes a spatial index to be created on the feature type at type creation time; `FALSE` does not cause a spatial index to be created.

`lockEnable` is a Boolean value: `TRUE` causes the feature type table (the underlying system-generated table where instances of this feature type are stored) to be lock-enabled at type creation time; `FALSE` does not cause the feature type table to be

lock-enabled. If `lockEnable` is `TRUE`, this will WFS-transaction lock enable the WFS data table for the feature type. (This data table is automatically generated when the feature type is published.)

`numPaths` is a list of numeric (`NUMBER`, `INTEGER`, and so on) related paths in the feature type. It is an `ArrayList` of class `oracle.spatial.ws.PathInfo`, which is described in [Section 15.4.7.1](#).

`idxPaths` is the index path list. It is list of paths on which to create an index of type `XDB.XMLINDEX` when that index is created. It is an `ArrayList` of class `oracle.spatial.ws.PathInfo`, which is described in [Section 15.4.7.1](#).

`idxPathTypes` specifies information about each index path, where each element of `string[3]` contains the following: `string[0]` is the type name, `string[1]` is the type format (such as the type length), and `string[2]` specifies whether a Btree or unique index, or no index, should be created (`WFSAdmin.BTREE`, `WFSAdmin.UNIQUE`, or `null`).

`genXMLIndex` is a Boolean value: `TRUE` causes an index of type `XDB.XMLINDEX` to be created on the document-based feature type; `FALSE` does not cause an index of type `XDB.XMLINDEX` to be created on the document-based feature type. If you choose not to create the index now, you can create it later using the `createXMLTableIndex` method (described in [Section 15.4.1](#)).

`featureCollectionNS` is the namespace of the feature collection.

`featureCollectionName` is the name of the feature collection.

`isGML3` is a Boolean value: `TRUE` means that the geometries inside instances of this feature type are GML3.1.1 compliant; `FALSE` means that the geometries inside instances of this feature type are GML 2.1.2 compliant.

`collPathInfo` is spatial collection path information.

`hasMultipleSRSNS` is a Boolean value: `TRUE` means that this feature type refers to multiple user-defined spatial reference system namespaces; `FALSE` means that this feature type does not refer to multiple user-defined spatial reference system namespaces.

15.4.7.1 Related Classes for `publishFeatureType`

This section describes some classes used in the definition of parameters of the [publishFeatureType](#) method.

`oracle.spatial.ws.PathElement` is a Java class that contains a pair of `String` objects: the `PathElement` namespace and the `PathElement` name. This class includes the `getValue()` method, which returns a string format of the `PathElement` object. This class has the following format:

```
public class PathElement {
// Set namespace and name information for a PathElement.
    public void set(String ns, String name);
//Get a string value for the PathElement object.
    public String getValue() ;
}
```

`oracle.spatial.ws.Path` is a Java class that contains an ordered list of `PathElement` objects that constitute the path. For example, if an XPath is `myns:A/myns:B`, then `myns:A` and `myns:B` are `PathElement` objects. This class includes the `getValue()` method, which returns a string format of the `Path` object. This class has the following format:

```
public class Path {
```

```

//Add a PathElement.
    public void add(PathElement p) ;
//Get a string Value for the Path object.
    public String getValue() ;
}

```

`oracle.spatial.ws.PathInfo` is a container class that contains information about a path or list of paths, including their association and metadata information. This class has the following format:

```

public class PathInfo {

    // Set number of occurrences for the Path. Default value is 1. Number of
    // occurrences > 1 in case of arrays.
    public void setNumOfOccurrences(int i) ;

    // Get number of occurrences for the Path.
    public int getNumOfOccurrences();

    // Add a path, in case PathInfo has multiple paths associated via a
    // choice association
    public void addPath(Path p) ;

    // Add path type information. This is relevant for time-related Paths
    // (for example, date, dateTime, gDay, gMonth, gYear, gMonthDay,
    // gYearMonth, duration, or time).
    public void addPathType(String t) ;

    // Add a PathInfo type. This can be PathInfo.CHOICE or
    // PathInfo.DEFAULT or PathInfo.COLLECTION.
    // PathInfo.CHOICE - means that the list of paths in this PathInfo are
    // related to each other via choice association. For example, we may have
    // a list of Spatial Paths, which are associated with one another via choice.
    // So, only one of these path can occur in a feature instance/document.
    // PathInfo.COLLECTION - means the list of paths in this PathInfo are part
    // of a collection (currently spatial collections are
    // supported) which will be indexed.
    // Default value is PathInfo.DEFAULT for one Path or a finite array Paths.
    // @param t PathInfo type information. PathInfo.CHOICE or
    // PathInfo.DEFAULT or PathInfo.COLLECTION
    public void addPathInfoType(int t) ;

    // Returns a string representation for PathInfo content.
    public String getPathContent() ;

    // Returns Path type information (for example, date, dateTime, gDay, gMonth,
    // gYear, gMonthDay, gYearMonth, duration, or time).
    public String getPathType() ;

    // Returns a string representation for PathInfo path content.
    // param i The index of the path in the PathInfo whose path content needs to
    // be returned
    // @return a string representation for PathInfo path content
    public String getCollectionPathContent(int i);

    // Returns number of paths in the PathInfo.
    // @return number of paths in the PathInfo which is of type PathInfo.COLLECTION
    // if PathInfo is not of type PathInfo.COLLECTION returns -1
    public int getCollectionPathContentSize();
}

```

`oracle.spatial.ws.CollectionPathInfo` is a container class that contains information about a collection of `PathInfo` objects. Each `PathInfo` object in this collection, represents a group of spatial paths that will be indexed and searched on. This class will be used to register paths referring to spatial collection-based content in feature and record types. This class has the following format:

```
public class CollectionPathInfo {

    /**
     * Add a PathInfo.
     * @param p PathInfo to be added
     * @param g geometry related metadata for PathInfo to be added
     */
    public void addPathInfo(PathInfo p, GeomMetaInfo g) ;

    /**
     * Get a PathInfo.
     * @param i index of the PathInfo to be retrieved
     */
    public PathInfo getPathInfo(int i) ;
    /**
     * Get geometry related metadata for a certain PathInfo.
     * @param i index of the PathInfo whose geomMetaInfo is to be retrieved
     */
    public GeomMetaInfo getGeomMetaInfo(int i) ;

    /**
     * Get all PathInfo objects in this CollectionPathInfo.
     */
    public ArrayList<PathInfo> getPathInfos() ;
}
```

`oracle.spatial.ws.GeoMetaInfo` is a class that contains dimension-related information corresponding to a spatial path in a feature type. This information includes the dimension name, the lower and upper bounds, the tolerance, and the coordinate system (SRID). This class has the following format:

```
public class GeoMetaInfo {

    // Default constructor. Creates a GeoMetaInfo object with number of
    // dimensions equal to 2.
    public GeoMetaInfo() ;

    // Creates a GeoMetaInfo object of a specified number of dimensions.
    // Parameter numOfDimensions is the number of dimensions represented
    // in the GeoMetaInfo object.
    // Note: max number of dimensions supported is 4.
    public GeoMetaInfo(int numOfDimensions) throws
        ArrayIndexOutOfBoundsException ;

    //Set Dimension Name.
    // Parameter index represents the dimension index which needs to be set.
    // Parameter val is dimension name value.
    public void setDimName(int index, String val) throws
        ArrayIndexOutOfBoundsException ;

    // Set Dimension Lower Bound.
    // Parameter index represents the dimension index which needs to be set.
    // Parameter val is dimension lower bound value.
```

```
        public void setLB(int index, double val) throws
            ArrayIndexOutOfBoundsException ;

// Set Dimension Upper Bound
// Parameter index represents the dimension index which needs to be set.
// Parameter val is dimension upper bound value
        public void setUB(int index, double val) throws
            ArrayIndexOutOfBoundsException ;

// Set Dimension tolerance value.
// Parameter index represents the dimension index which needs to be set.
// Parameter val is dimension tolerance value.
        public void setTolerance(int index, double val) throws
            ArrayIndexOutOfBoundsException ;

// Set Coordinate Reference System Identifier
        public void setSRID (int val) ;

// Get dimension Name.
// Parameter index represents the dimension index whose name needs to be
// returned. This method returns the dimension name for the given index.
        public String getDimName(int index) throws
            ArrayIndexOutOfBoundsException ;

// Get dimension lower bound.
// Parameter index represents the dimension index whose lower bound needs
// to be returned.
// This method returns the lower bound for the given index.
        public double getLB(int index) throws ArrayIndexOutOfBoundsException ;

// Get dimension upper bound.
// Parameter index represents the dimension index whose upper bound needs
// to be returned.
// This method returns the upper bound for the given index.
        public double getUB(int index) throws ArrayIndexOutOfBoundsException ;

// Get dimension tolerance.
// Parameter index represents the dimension index whose tolerance needs
// to be returned.
// This method returns the tolerance value for the given index.
        public double getTolerance(int index) throws
            ArrayIndexOutOfBoundsException ;

// Get coordinate system (spatial reference system) identifier.
        public int getSRID () ;

// Get number of dimensions represented by this GeomMetaInfo object.
        public int getNumOfDimensions() ;

// Sets the spatial index dimension parameter. By default it is 2.
// return Coordinate Reference System Identifier value
        public int setSpatialIndexDimension(int d) ;

// Get the spatial index dimension parameter.
// return number of dimensions
        public int getSpatialIndexDimension() ;

// Sets the user spatial srs namespace referred by this GeomMetaInfo object.
// Needs to be specified if multiple srs namespace are referred within the same
//feature or record type.
```



```

        public void setSRSNS(String s) ;

        // Gets the user defined spatial srs namespace referred by this
        // GeomMetaInfo object.
        public String getSRSNS() ;

        // Sets the user defined spatial srs namespace alias referred by this
        // GeomMetaInfo object.
        public void setSRSNSAlias (String s) ;

        // Gets the user defined spatial srs namespace alias referred by this
        // GeomMetaInfo object.
        public String getSRSNSAlias () ;
    }

```

15.4.8 revokeFeatureTypeFromUser method

The `revokeFeatureTypeFromUser` method revokes access to a feature type from a database user. This method has the following format:

```

public static void revokeFeatureTypeFromUser(
    OracleConnection conn,
    String typeNS,
    String typeName,
    String usrName) throws SQLException;

```

`conn` is an Oracle Database connection for a user that has been granted the DBA role.

`typeNS` is the URL of the namespace of the feature type.

`typeName` is the name of the feature type.

`usrName` is the name of the database user.

15.4.9 revokeMDAccessFromUser method

The `revokeMDAccessFromUser` method revokes access to the WFS metadata from a database user. This method has the following format:

```

public static void revokeMDAccessFromUser(
    OracleConnection conn,
    String usrName) throws SQLException;

```

`conn` is an Oracle Database connection for a user that has been granted the DBA role.

`usrName` is the name of the database user.

15.4.10 setXMLTableIndexInfo method

The `setXMLTableIndexInfo` method updates the XMLTableIndex index information for a document-based feature type, with the option of creating the index. This method has the following format:

Note: If the XMLTableIndex index already exists, you must drop it (using the [dropXMLTableIndex method](#)) before you call the `setXMLTableIndexInfo` method.

```

public static void setXMLTableIndexInfo(OracleConnection conn,
    String ftNSUrl,

```

```
String ftName,
ArrayList<PathInfo> idxPaths,
ArrayList<String[]> idxPathTypes,
boolean genXMLIndex) throws SQLException , WFSException;
```

`conn` is an Oracle Database connection for a user that has been granted the DBA role.

`ftNSUrl` is the URL of the namespace of the feature type.

`ftName` is the name of the feature type.

`idxPaths` is the index path list. It is list of paths on which to create an index of type XDB.XMLINDEX when that index is created. It is an `ArrayList` of class `oracle.spatial.ws.PathInfo`, which is described in [Section 15.4.7.1](#).

`idxPathTypes` specifies information about each index path, where each element of `string[3]` contains the following: `string[0]` is the type name, `string[1]` is the type format (such as the type length), and `string[2]` specifies whether a Btree or unique index, or no index, should be created (`WFSAdmin.BTREE`, `WFSAdmin.UNIQUE`, or null).

`genXMLIndex` is a Boolean value: `TRUE` causes an index of type XDB.XMLINDEX to be created on the document-based feature type; `FALSE` does not cause an index of type XDB.XMLINDEX to be created on the document-based feature type. If you choose not to create the index now, you can create it later using the `createXMLTableIndex` method (described in [Section 15.4.1](#)).

15.5 Using WFS with Oracle Workspace Manager

You can use Oracle Workspace Manager to version-enable a WFS table with relational features. To do so, first register the WFS table using the [SDO_WFS_LOCK.RegisterFeatureTable](#) procedure; then execute the `DBMS_WM.EnableVersioning` procedure. (For information about Workspace Manager, including reference documentation for the `DBMS_WM` PL/SQL package, see *Oracle Database Workspace Manager Developer's Guide*.)

You can create workspaces and perform transactional WFS changes to these workspaces by using the WFS-T (Web Feature Services transaction) interfaces. However, to use interfaces other than WFS-T, you must use a SQL*Plus session for which database transactions are enabled on the WFS tables. These database transactions include the following:

- Update and delete operations on WFS tables
- Workspace maintenance operations, such as refreshing a workspace or merging workspaces

To enable database transactions on the WFS tables, call the [SDO_WFS_LOCK.EnableDBTxns](#) procedure (documented in [Chapter 33](#)). After you execute this procedure, database transactions are permitted on the WFS tables and WFS-T semantics are maintained for WFS transactions, until the end of the session.

Catalog Services for the Web (CSW) Support

This chapter describes the Oracle Spatial implementation of the Open GIS Consortium specification for catalog services. According to this specification: "Catalogue services support the ability to publish and search collections of descriptive information (metadata) for data, services, and related information objects. Metadata in catalogues represent resource characteristics that can be queried and presented for evaluation and further processing by both humans and software. Catalogue services are required to support the discovery and binding to registered information resources within an information community."

The Oracle Spatial implementation will be referred to as Catalog Services for the Web, or CSW

This chapter includes the following major sections:

- [Section 16.1, "CSW Engine and Architecture"](#)
- [Section 16.2, "CSW APIs and Configuration"](#)
- [Section 16.3, "Request and Response XML Examples"](#)
- [Section 16.4, "Java API for CSW Administration"](#)

Note: Before you use CSW, be sure that you understand the concepts described in [Chapter 10, "Introduction to Spatial Web Services"](#), and that you have performed any necessary configuration work as described in that chapter.

If you have data from a previous release that was indexed using one or more SYS.XMLTABLEINDEX indexes, you must drop the associated indexes before the upgrade and re-create the indexes after the upgrade, as described in [Section A.2](#).

16.1 CSW Engine and Architecture

This section describes CSW, including its relationship to clients and to the database server. CSW is implemented as a Web service and can be deployed in a WebLogic Server, Oracle Application Server, or standalone Oracle Application Server Containers for J2EE (OC4J) environment.

CSW has a metadata layer, which stores in the database the metadata needed to reply to catalog requests. The metadata includes spatial columns, which can be queried and processed using Oracle Spatial interfaces. The metadata also stores the association of

nonspatial and spatial attributes of records, as well as the services that the catalog service provides to its clients.

Figure 16–1 shows the CSW architecture.

Figure 16–1 CSW Architecture

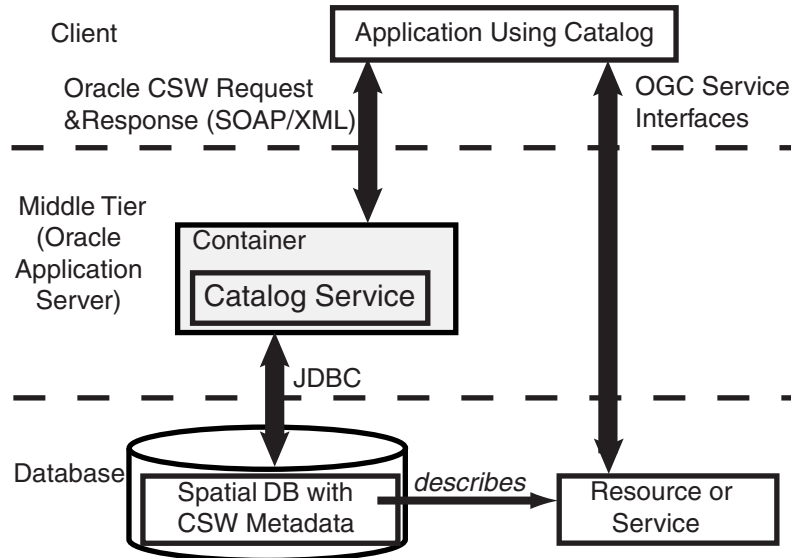

As shown in Figure 16–1:

- CSW is part of a container in the Oracle Application Server middle tier.
- CSW can communicate with a Web service client using CSW requests and responses in SOAP/XML format.
- CSW performs spatial data and metadata access through JDBC calls to the database.
- The database includes Oracle Spatial with CSW metadata and data.

CSW security is implemented using secure transport. User identities and user labels are managed in LDAP, and the middle tier and CSW security combine to perform authentication. Oracle label-based security is used for managing user privileges at the record level.

16.2 CSW APIs and Configuration

The CSW APIs enable you to perform operations that include:

- Specifying information about record type domains and record view transformations
- Publishing record types
- Dropping (unpublishing) record types
- Granting to users and revoking from users privileges on CSW record types

Chapter 22 describes the PL/SQL API (SDO_CSW_PROCESS package), Section 16.3 provides examples of XML requests and responses, and Section 16.4 describes the Java API.

16.2.1 Capabilities Documents

A capabilities document describes an instance of a capability. The document specifies a record type and the type of operations supported (such as insert and delete).

A capabilities document is generated by the CSW server in response to a GetCapabilities request. The CSW server uses a capabilities template, and adds information about the record type and operations to this template to create the capabilities document.

The client can use the HTTP GET method to access this capabilities document using either the SOAP interface or the XML interface:

- For the SOAP interface, use `oracle.spatial.ws.servlet.CSWServlet`, which can be accessed at an address in the following format:

```
http://machine-name:port/SpatialWS-SpatialWS-context-root/cswservlet?request=GetCapabilities&service=CSW&acceptversion=2.0.0&outputFormat=text/xml
```

- For the XML interface, use `oracle.spatial.ws.servlet.CSWXMLServlet`, which can be accessed at an address in the following format:

```
http://machine-name:port/SpatialWS-SpatialWS-context-root/xmlcswservlet?request=GetCapabilities&service=CSW&acceptversion=2.0.0&outputFormat=text/xml
```

In the preceding formats:

- *machine-name* is the name of the system where the application server or OC4J server is running.
- *port* is the port number where the application server or OC4J server is running.
- *SpatialWS-SpatialWS-context-root* is the default root where the Spatial Web services application is mounted.
- *cswservlet* is the servlet-mapping url-pattern for `oracle.spatial.ws.servlet.CSWServlet`, as specified by default in the `web.xml` file.
- *xmlcswservlet* is the servlet-mapping url-pattern for `oracle.spatial.ws.servlet.CSWXMLServlet`, as specified by default in the `web.xml` file.

16.2.2 Spatial Path Extractor Function (extractSDO)

If you need CSW to process any spatial content that is not in GML format, you must create a user-defined function named `extractSDO` to extract the spatial path information. This function must be implemented for each record type that has spatial content in non-GML format and on which you want to create a spatial index. (This function is not needed if all spatial content for a record type is in GML format.)

This function must be registered, as explained in [Section 16.2.2.1](#), so that the Oracle Spatial CSW server can find and invoke this function when it needs to extract spatial path content that is not in GML format.

The `extractSDO` function has the following format:

```
extractSDO(
    xmlData          IN XMLType,
    srsNs            IN VARCHAR2,
    spPathsSRSNSList IN MDSYS.STRINGLISTLIST);
```

```
) RETURN MDSYS.SDO_GEOM_PATH_INFO;
```

Parameters

xmlData

Data of the record instance from which spatial path information needs to be extracted.

srsNs

User-defined namespace of the spatial reference system (coordinate system) associated with the spatial data for the feature type. This namespace (if specified) is also used to generate the `srsName` attribute in the `<boundedBy>` element of the `FeatureCollection` result generated for the `GetFeature` request.

spPathsSRSNSList

If a record type has multiple user-defined spatial reference system namespaces associated with different spatial paths, this parameter specifies the list of spatial reference system namespace information corresponding to the different spatial paths specified during type registration. It is an object of type `MDSYS.STRINGLISTLIST`, which is defined as `VARRAY(1000000) OF MDSYS.STRINGLIST`, and where `MDSYS.STRINGLIST` is defined as `VARRAY(1000000) OF VARCHAR2(4000)`. If a record type does not have multiple user-defined spatial reference system namespaces associated with different spatial columns, this parameter should be null.

In each `MDSYS.STRINGLIST` object, the first element is the spatial reference system namespace, and second element is the spatial reference system namespace alias (if any).

Usage Notes

This function parses the non-GML spatial content and returns an object of type `MDSYS.SDO_GEOM_PATH_INFO`, which is defined as follows:

```
(path      MDSYS.STRINGLIST,
 geom      SDO_GEOMETRY,
 arrindex  NUMBER)
```

The `path` attribute specifies path to the spatial content that is to be extracted and stored in the `geom` attribute. It is an object of `MDSYS.STRINGLIST`, which is defined as: `VARRAY(1000000) OF VARCHAR2(4000)`. The `path` attribute has the following pattern: `MDSYS.STRINGLIST('pe_namespace1', 'pe_name1', 'pe_namespace2', 'pe_name2', ...)`; where:

- `pe_namespace1` is the namespace of the first path element.
- `pe_name1` is the name of the first path element.
- `pe_namespace2` is the namespace of the second path element.
- `pe_name2` is the name of the second path element.
- and so on, for any remaining namespace and name pairs.

In the `path`, `/typeNameNSAlias:typeName/pe_namespace1_Alias:pe_name1/pe_namespace2_Alias:pe_name2...` is an XPath representation of spatial content, in non-GML format, that will be extracted by the user-defined function `extractSDO`:

- `typeNameNSAlias` is an alias to record type name namespace.
- `typeName` is the type name of the record type.
- `pe_namespace1_Alias` is a namespace alias for namespace `pe_namespace1`

- `pe_namespace2_Alias` is a namespace alias for namespace `pe_namespace2`.

The `geom` attribute is the spatial content (corresponding to the `path` parameter) extracted as an `SDO_GEOMETRY` object. The extracted geometry can then be indexed using a spatial index.

The `arrindex` attribute is not currently used, and should be set to 1. (It is reserved for future use as an array index of paths.)

16.2.2.1 Registering and Unregistering the `extractSDO` Function

After you create the `extractSDO` function, you must register it to enable it to be used for processing spatial path content in record types that is not in GML format. To register the function, call the [SDO_CSW_PROCESS.InsertPluginMap](#) procedure. For example:

```
BEGIN
  SDO_CSW_PROCESS.insertPluginMap('http://www.opengis.net/cat/csw',
    'Record', 'csw_admin_usr.csw_RT_1_package');
END;
/
```

If you no longer want the `extractSDO` function to be used for processing spatial path content that is not in GML format, you can unregister the function by calling the [SDO_CSW_PROCESS.DeletePluginMap](#) procedure. For example:

```
BEGIN
  SDO_CSW_PROCESS.deletePluginMap('http://www.opengis.net/cat/csw',
    'Record');
END;
/
```

16.3 Request and Response XML Examples

This section presents some record requests to the CSW engine, and the response to each request, for each of the following operations:

- GetCapabilities
- DescribeRecord
- GetRecords
- GetDomain
- GetRecordById
- Transaction, with a subelement specifying the transaction type:
 - Insert
 - Update
 - Delete

[Example 16–1](#) is a request to get the capabilities of the CSW server named CSW at a specified namespace URL. This request will return a capabilities document, as explained in [Section 16.2.1](#)

Example 16–1 GetCapabilities Request

```
<csw:GetCapabilities service="CSW" xmlns:csw="http://www.opengis.net/cat/csw"
xmlns:ows="http://www.opengis.net/ows">
  <ows:AcceptVersions>
```

```

        <ows:Version>2.0.0</ows:Version>
    </ows:AcceptVersions>
    <ows:AcceptFormats>
        <ows:OutputFormat>text/xml</ows:OutputFormat>
    </ows:AcceptFormats>
</csw:GetCapabilities>

```

Example 16–2 is an excerpt of the response from the request in Example 16–1.

Example 16–2 GetCapabilities Response

```

<Capabilities xmlns="http://www.opengis.net/cat/csw" version="2.0.0" updateSequence="0"
xmlns:ows="http://www.opengis.net/ows" xmlns:ogc="http://www.opengis.net/ogc"
xmlns:csw="http://www.opengis.net/cat/csw" xmlns:xlink="http://www.w3.org/1999/xlink"
xmlns:ns0="http://www.opengis.net/cat/csw" xmlns:ns1="http://www.opengis.net/cat/csw">
  <ows:ServiceIdentification xmlns:ows="http://www.opengis.net/ows">
    <ows:ServiceType>CSW</ows:ServiceType>
    <ows:ServiceTypeVersion>2.0.0</ows:ServiceTypeVersion>
    <ows:Title>Company CSW</ows:Title>
    <ows:Abstract>
      A catalogue service that conforms to the HTTP protocol
      binding of the OpenGIS Catalogue Service specification
      version 2.0.0.
    </ows:Abstract>
    <ows:Keywords>
      <ows:Keyword>CSW</ows:Keyword>
      <ows:Keyword>Company Name</ows:Keyword>
      <ows:Keyword>geospatial</ows:Keyword>
      <ows:Keyword>catalogue</ows:Keyword>
    </ows:Keywords>
    <ows:Fees>NONE</ows:Fees>
    <ows:AccessConstraints>NONE</ows:AccessConstraints>
  </ows:ServiceIdentification>
  <ows:ServiceProvider xmlns:ows="http://www.opengis.net/ows">
    <ows:ProviderName>Company Name</ows:ProviderName>
    <ows:ProviderSite ans1:href="http://www.oracle.com" xmlns:ans1="http://www.w3.org/1999/xlink"/>
    <ows:ServiceContact>
      <ows:IndividualName> Contact Person Name</ows:IndividualName>
      <ows:PositionName>Staff</ows:PositionName>
      <ows:ContactInfo>
        <ows:Phone>
          <ows:Voice>999-999-9999</ows:Voice>
          <ows:Facsimile>999-999-9999</ows:Facsimile>
        </ows:Phone>
        <ows:Address>
          <ows:DeliveryPoint>1 Street Name</ows:DeliveryPoint>
          <ows:City>CityName</ows:City>
          <ows:AdministrativeArea>StateName</ows:AdministrativeArea>
          <ows:PostalCode>09999</ows:PostalCode>
          <ows:Country>USA</ows:Country>
          <ows:ElectronicMailAddress>
            contact.person@example.com
          </ows:ElectronicMailAddress>
        </ows:Address>
        <ows:OnlineResource ans1:href="mailto:contact.person@example.com"
xmlns:ans1="http://www.w3.org/1999/xlink"/>
      </ows:ContactInfo>
    </ows:ServiceContact>
  </ows:ServiceProvider>
  <ows:OperationsMetadata xmlns:ows="http://www.opengis.net/ows">

```



```

<ows:Operation name="GetCapabilities">
  <ows:DCP>
    <ows:HTTP>
      <ows:Get ans1:href="http://localhost:8888/SpatialWS-SpatialWS-context-root/cswservlet"
xmlns:ans1="http://www.w3.org/1999/xlink"/>
    <ows:Post
ans1:href="http://localhost:8888/SpatialWS-SpatialWS-context-root/SpatialWSSoapHttpPort"
xmlns:ans1="http://www.w3.org/1999/xlink"/>
    </ows:HTTP>
  </ows:DCP>
</ows:Operation>
<ows:Operation name="DescribeRecord">
  <ows:DCP>
    <ows:HTTP>
      <ows:Post
ans1:href="http://localhost:8888/SpatialWS-SpatialWS-context-root/SpatialWSSoapHttpPort"
xmlns:ans1="http://www.w3.org/1999/xlink"/>
    </ows:HTTP>
  </ows:DCP>
  <ows:Parameter
name="typeName"><ows:Value>ns0:SampleRecord</ows:Value><ows:Value>ns1:Record</ows:Value></ows:Param
eter>
    <ows:Parameter name="outputFormat">
      <ows:Value>text/xml</ows:Value>
    </ows:Parameter>
    <ows:Parameter name="schemaLanguage">
      <ows:Value>XMLSCHEMA</ows:Value>
    </ows:Parameter>
  </ows:Operation>
<ows:Operation name="GetRecords">
  <ows:DCP>
    <ows:HTTP>
      <ows:Post
ans1:href="http://localhost:8888/SpatialWS-SpatialWS-context-root/SpatialWSSoapHttpPort"
xmlns:ans1="http://www.w3.org/1999/xlink"/>
    </ows:HTTP>
  </ows:DCP>
  <ows:Parameter
name="TypeName"><ows:Value>ns0:SampleRecord</ows:Value><ows:Value>ns1:Record</ows:Value></ows:Param
eter>
    <ows:Parameter name="outputFormat">
      <ows:Value>text/xml </ows:Value>
    </ows:Parameter>
    <ows:Parameter name="outputSchema">
      <ows:Value>OGCCORE</ows:Value>
    </ows:Parameter>
    <ows:Parameter name="resultType">
      <ows:Value>hits</ows:Value>
      <ows:Value>results</ows:Value>
      <ows:Value>validate</ows:Value>
    </ows:Parameter>
    <ows:Parameter name="ElementSetName">
      <ows:Value>brief</ows:Value>
      <ows:Value>summary</ows:Value>
      <ows:Value>full</ows:Value>
    </ows:Parameter>
    <ows:Parameter name="CONSTRAINTLANGUAGE">
      <ows:Value>Filter</ows:Value>
    </ows:Parameter>
  </ows:Operation>

```

```

<ows:Operation name="GetRecordById">
  <ows:DCP>
    <ows:HTTP>
      <ows:Post
ans1:href="http://localhost:8888/SpatialWS-SpatialWS-context-root/SpatialWSSoapHttpPort"
xmlns:ans1="http://www.w3.org/1999/xlink"/>
      </ows:HTTP>
    </ows:DCP>
    <ows:Parameter name="ElementSetName">
      <ows:Value>brief</ows:Value>
      <ows:Value>summary</ows:Value>
      <ows:Value>full</ows:Value>
    </ows:Parameter>
  </ows:Operation>
<ows:Operation name="GetDomain">
  <ows:DCP>
    <ows:HTTP>
      <ows:Post
ans1:href="http://localhost:8888/SpatialWS-SpatialWS-context-root/SpatialWSSoapHttpPort"
xmlns:ans1="http://www.w3.org/1999/xlink"/>
      </ows:HTTP>
    </ows:DCP>
    <ows:Parameter name="ParameterName">
      <ows:Value>GetRecords.resultType</ows:Value>
      <ows:Value>GetRecords.outputFormat</ows:Value>
      <ows:Value>GetRecords.outputRecType</ows:Value>
      <ows:Value>GetRecords.typeNames</ows:Value>
      <ows:Value>GetRecords.ElementSetName</ows:Value>
      <ows:Value>GetRecords.ElementName</ows:Value>
      <ows:Value>GetRecords.CONSTRAINTLANGUAGE</ows:Value>
      <ows:Value>GetRecordById.ElementSetName</ows:Value>
      <ows:Value>DescribeRecord.typeName</ows:Value>
      <ows:Value>DescribeRecord.schemaLanguage</ows:Value>
    </ows:Parameter>
  </ows:Operation>
<ows:Operation name="Transaction">
  <ows:DCP>
    <ows:HTTP>
      <ows:Post
ans1:href="http://localhost:8888/SpatialWS-SpatialWS-context-root/SpatialWSSoapHttpPort"
xmlns:ans1="http://www.w3.org/1999/xlink"/>
      </ows:HTTP>
    </ows:DCP>
  </ows:Operation>
<ows:Parameter name="service">
  <ows:Value>CSW</ows:Value>
</ows:Parameter>
<ows:Parameter name="version">
  <ows:Value>2.0.0</ows:Value>
</ows:Parameter>
<ows:ExtendedCapabilities>
  <ogc:Filter_Capabilities xmlns:ogc="http://www.opengis.net/ogc">
    <ogc:Spatial_Capabilities>
      <ogc:Spatial_Operators>
        <ogc:BBOX/>
        <ogc:Equals/>
        <ogc:Disjoint/>
        <ogc:Intersect/>
        <ogc:Touches/>
        <ogc:Crosses/>
      </ogc:Spatial_Operators>
    </ogc:Spatial_Capabilities>
  </ogc:Filter_Capabilities>

```

```

    <ogc:Within/>
    <ogc:Contains/>
    <ogc:Overlaps/>
    <ogc:Beyond/>
    <ogc:DWithin/>
  </ogc:Spatial_Operators>
</ogc:Spatial_Capabilities>
<ogc:Scalar_Capabilities>
  <ogc:Logical_Operators/>
  <ogc:Comparison_Operators>
    <ogc:Simple_Comparisons/>
    <ogc:Like/>
    <ogc:Between/>
    <ogc:NullCheck/>
  </ogc:Comparison_Operators>
  <ogc:Arithmetic_Operators>
    <ogc:Simple_Arithmetic/>
  </ogc:Arithmetic_Operators>
</ogc:Scalar_Capabilities>
</ogc:Filter_Capabilities>
</ows:ExtendedCapabilities>
</ows:OperationsMetadata>
</Capabilities>

```

[Example 16-3](#) is a request to describe the record with the type name `Record` for a specified namespace.

Example 16-3 DescribeRecord Request

```

<csw:DescribeRecord service="CSW"
  version="2.0.0"
  xmlns:csw="http://www.opengis.net/cat/csw" >
  <csw:TypeName
targetNamespace="http://www.opengis.net/cat/csw">Record</csw:TypeName>
</csw:DescribeRecord>

```

[Example 16-4](#) is the response from the request in [Example 16-3](#). The response is an XML schema definition (XSD). See the `<documentation>` elements in the response for explanatory comments.

Example 16-4 DescribeRecord Response

```

<xsd:schema targetNamespace="http://www.opengis.net/cat/csw"
  elementFormDefault="qualified" version="2.0.0" id="csw-record"
  xmlns:csw="http://www.opengis.net/cat/csw"
  xmlns:dc="http://www.purl.org/dc/elements/1.1/"
  xmlns:dct="http://www.purl.org/dc/terms/" xmlns:ows="http://www.opengis.net/ows"
  xmlns:xsd="http://www.w3.org/2001/XMLSchema">
  <xsd:annotation>
    <xsd:appinfo>
      <dc:identifier xmlns:dc="http://www.purl.org/dc/elements/1.1/">
        http://schemas.opengis.net/csw/2.0.0/record
      </dc:identifier>
    </xsd:appinfo>
    <xsd:documentation xml:lang="en">
      This schema defines the basic record types that are common to all CSW
      implementations. An application profile may extend AbstractRecordType to
      represent model-specific content.
    </xsd:documentation>
  </xsd:annotation>

```

```
<xsd:import namespace="http://www.purl.org/dc/terms/"
schemaLocation="./recdcterms.xsd"/>
<xsd:import namespace="http://www.purl.org/dc/elements/1.1/"
schemaLocation="./recdcmes.xsd"/>
<xsd:import namespace="http://www.opengis.net/ows"
schemaLocation="./owsboundingbox.xsd"/>
<xsd:element name="AbstractRecord" type="csw:AbstractRecordType" abstract="true"
id="AbstractRecord"/>
<xsd:complexType name="AbstractRecordType" abstract="true"
id="AbstractRecordType"/>
<xsd:element name="DCMIRecord" type="csw:DCMIRecordType"
substitutionGroup="csw:AbstractRecord"/>
<xsd:complexType name="DCMIRecordType">
  <xsd:annotation>
    <xsd:documentation xml:lang="en">
      This type encapsulates all of the standard DCMI metadata terms,
      including the Dublin Core refinements; these terms may be mapped to the
      profile-specific information model.
    </xsd:documentation>
  </xsd:annotation>
  <xsd:complexContent>
    <xsd:extension base="csw:AbstractRecordType">
      <xsd:sequence>
        <xsd:group ref="dct:DCMI-terms"/>
      </xsd:sequence>
    </xsd:extension>
  </xsd:complexContent>
</xsd:complexType>
<xsd:element name="BriefRecord" type="csw:BriefRecordType"
substitutionGroup="csw:AbstractRecord"/>
<xsd:complexType name="BriefRecordType">
  <xsd:annotation>
    <xsd:documentation xml:lang="en">
      This type defines a brief representation of the common record format.
      It extends AbstractRecordType to include only the dc:identifier and
      dc:type properties.
    </xsd:documentation>
  </xsd:annotation>
  <xsd:complexContent>
    <xsd:extension base="csw:AbstractRecordType">
      <xsd:sequence>
        <xsd:element ref="dc:identifier"/>
        <xsd:element ref="dc:type" minOccurs="0"/>
      </xsd:sequence>
    </xsd:extension>
  </xsd:complexContent>
</xsd:complexType>
<xsd:element name="SummaryRecord" type="csw:SummaryRecordType"
substitutionGroup="csw:AbstractRecord"/>
<xsd:complexType name="SummaryRecordType">
  <xsd:annotation>
    <xsd:documentation xml:lang="en">
      This type defines a summary representation of the common record format.
      It extends AbstractRecordType to include the core properties.
    </xsd:documentation>
  </xsd:annotation>
  <xsd:complexContent>
    <xsd:extension base="csw:AbstractRecordType">
      <xsd:sequence>
        <xsd:choice maxOccurs="unbounded">
```

```

        <xsd:element ref="dc:identifier"/>
        <xsd:element ref="dc:type"/>
        <xsd:element ref="dc:title"/>
        <xsd:element ref="dc:subject"/>
        <xsd:element ref="dc:format"/>
        <xsd:element ref="dc:relation"/>
        <xsd:element ref="dct:modified"/>
        <xsd:element ref="dct:abstract"/>
        <xsd:element ref="dct:spatial"/>
    </xsd:choice>
</xsd:sequence>
</xsd:extension>
</xsd:complexContent>
</xsd:complexType>
<xsd:element name="Record" type="csw:RecordType"
substitutionGroup="csw:AbstractRecord"/>
<xsd:complexType name="RecordType">
    <xsd:annotation>
        <xsd:documentation xml:lang="en">
            This type extends DCMIRecordType to add ows:BoundingBox; it may be used
            to specify a bounding envelope for the catalogued resource.
        </xsd:documentation>
    </xsd:annotation>
    <xsd:complexContent>
        <xsd:extension base="csw:DCMIRecordType">
            <xsd:sequence>
                <xsd:element ref="ows:BoundingBox" minOccurs="0"/>
            </xsd:sequence>
        </xsd:extension>
    </xsd:complexContent>
</xsd:complexType>
</xsd:schema>

```

Example 16–5 is a request to get records where the contributor is equal to Raja.

Note: Spatial Catalog Service in Oracle Database Release 11.1 supports only synchronous processing of GetRecords requests.

Example 16–5 *GetRecords Request*

```

<?xml version="1.0" ?>
<csw:GetRecords
  service="CSW"
  version="2.0.0"
  xmlns:csw="http://www.opengis.net/cat/csw"
  xmlns:ogc="http://www.opengis.net/ogc"
  xmlns:dc="http://www.purl.org/dc/elements/1.1/"
  xmlns:dct="http://www.purl.org/dc/terms/"
  outputFormat="text/xml"
  resultType="results"
  outputSchema="csw:Record">
<csw:Query typeNames="csw:Record">
<csw:ElementName>/csw:Record/dc:identifier</csw:ElementName>
<csw:ElementName>/csw:Record/dc:contributor</csw:ElementName>
<csw:Constraint version="2.0.0" >
  <ogc:Filter>
    <ogc:PropertyIsEqualTo>
      <ogc:PropertyName>/csw:Record/dc:contributor</ogc:PropertyName>
      <ogc:Literal>Raja</ogc:Literal>
    </ogc:PropertyIsEqualTo>
  </ogc:Filter>
</csw:Constraint>
</csw:Query>
</csw:GetRecords>

```

```

    </ogc:PropertyIsEqualTo>
    </ogc:Filter>
</csw:Constraint>
</csw:Query>
</csw:GetRecords>

```

[Example 16–6](#) is the response from the request in [Example 16–5](#).

Example 16–6 GetRecords Response

```

<csw:GetRecordsResponse xmlns:csw="http://www.opengis.net/cat/csw"
xmlns:dc="http://www.purl.org/dc/elements/1.1/"
xmlns:dct="http://www.purl.org/dc/terms/"
xsi:schemaLocation="http://www.opengis.net/cat/csw
http://localhost:8888/SpatialWS-SpatialWS-context-root/cswservlet?recordTypeId=1 "
version="2.0.0" xmlns:xsi="http://www.w3.org/2001/XMLSchema-instance">
    <csw:RequestId>4</csw:RequestId>
    <csw:SearchStatus status="complete" />
    <csw:SearchResults recordSchema="http://www.opengis.net/cat/csw"
numberOfRecordsMatched="1" numberOfRecordsReturned="1" nextRecord="0"
expires="2007-02-09T16:32:35.29Z">
        <csw:Record xmlns:dc="http://www.purl.org/dc/elements/1.1/"
xmlns:ows="http://www.opengis.net/ows" xmlns:dct="http://www.purl.org/dc/terms/">
            <dc:contributor xmlns:dc="http://www.purl.org/dc/elements/1.1/"
scheme="http://www.example.com">Raja</dc:contributor>
            <dc:identifier
xmlns:dc="http://www.purl.org/dc/elements/1.1/">REC-1</dc:identifier>
        </csw:Record>
    </csw:SearchResults>
</csw:GetRecordsResponse>

```

[Example 16–7](#) is a request to get domain information related to a record type.

Example 16–7 GetDomain Request

```

<csw:GetDomain service="CSW"
version="2.0.0"
xmlns:csw="http://www.opengis.net/cat/csw" >
    <csw:ParameterName>GetRecords.resultType</csw:ParameterName>
</csw:GetDomain>

```

[Example 16–8](#) is the response from the request in [Example 16–7](#).

Example 16–8 GetDomain Response

```

<csw:GetDomainResponse xmlns:csw="http://www.opengis.net/cat/csw"
xmlns:dc="http://www.purl.org/dc/elements/1.1/"
xmlns:dct="http://www.purl.org/dc/terms/">
    <csw:DomainValues type="csw:SampleRecord">
        <csw:ParameterName>GetRecords.resultType</csw:ParameterName>
        <csw:ListOfValues>
            <csw:Value>hits</csw:Value>
            <csw:Value>results</csw:Value>
            <csw:Value>validate</csw:Value>
        </csw:ListOfValues>
    </csw:DomainValues>
    <csw:DomainValues type="csw:Record">
        <csw:ParameterName>GetRecords.resultType</csw:ParameterName>
        <csw:ListOfValues>
            <csw:Value>hits</csw:Value>
            <csw:Value>results</csw:Value>
        </csw:ListOfValues>
    </csw:DomainValues>

```

```

        <csw:Value>validate</csw:Value>
    </csw:ListOfValues>
</csw:DomainValues>
</csw:GetDomainResponse>

```

[Example 16-9](#) is a request to get the record with the record ID value REC-1.

Example 16-9 GetRecordById Request

```

<?xml version="1.0" ?>
<csw:GetRecordById
  service="CSW"
  version="2.0.0"
  xmlns:csw="http://www.opengis.net/cat/csw"
  xmlns:ogc="http://www.opengis.net/ogc" >
<csw:Id> REC-1 </csw:Id>
<csw:ElementSetName>brief</csw:ElementSetName>
</csw:GetRecordById>

```

[Example 16-10](#) is the response from the request in [Example 16-9](#).

Example 16-10 GetRecordById Response

```

<csw:GetRecordByIdResponse xmlns:csw="http://www.opengis.net/cat/csw"
xmlns:dc="http://www.purl.org/dc/elements/1.1/"
xmlns:dct="http://www.purl.org/dc/terms/"
xsi:schemaLocation="http://www.opengis.net/cat/csw
http://localhost:8888/SpatialWS-SpatialWS-context-root/cswservlet?recordTypeId=2
http://www.opengis.net/cat/csw
http://localhost:8888/SpatialWS-SpatialWS-context-root/cswservlet?recordTypeId=1 "
xmlns:xsi="http://www.w3.org/2001/XMLSchema-instance">
  <csw:BriefRecord xmlns:dc="http://www.purl.org/dc/elements/1.1/"
xmlns:ows="http://www.opengis.net/ows" xmlns:dct="http://www.purl.org/dc/terms/">
    <dc:identifier
xmlns:dc="http://www.purl.org/dc/elements/1.1/">REC-1</dc:identifier>
  </csw:BriefRecord>
</csw:GetRecordByIdResponse>

```

[Example 16-11](#) is a request to insert a record for contributor John. The record has an ID value of REC-2, and has the spatial attribute of the specified bounding box (optimized rectangle: lower-left and upper-right coordinates).

Example 16-11 Insert Request

```

<csw:Transaction service="CSW"
  version="2.0.0"
  xmlns:csw="http://www.opengis.net/cat/csw" >
  <csw:Insert>
    <Record xmlns="http://www.opengis.net/cat/csw"
xmlns:dc="http://www.purl.org/dc/elements/1.1/"
xmlns:dct="http://www.purl.org/dc/terms/" xmlns:ows="http://www.opengis.net/ows" >
      <dc:contributor scheme="http://www.example.com">John</dc:contributor>
      <dc:identifier >REC-2</dc:identifier>
      <ows:WGS84BoundingBox crs="urn:opengis:crs:OGC:2:84" dimensions="2">
        <ows:LowerCorner>12 12</ows:LowerCorner>
        <ows:UpperCorner>102 102</ows:UpperCorner>
      </ows:WGS84BoundingBox>
    </Record>
  </csw:Insert>
</csw:Transaction>

```

[Example 16–12](#) is the response from the request in [Example 16–11](#).

Example 16–12 Insert Response

```
<csw:TransactionResponse xmlns:csw="http://www.opengis.net/cat/csw"
xmlns:dc="http://www.purl.org/dc/elements/1.1/"
xmlns:dct="http://www.purl.org/dc/terms/"
xsi:schemaLocation="http://www.opengis.net/cat/csw
http://localhost:8888/SpatialWS-SpatialWS-context-root/cswservlet?recordTypeId=1 "
xmlns:xsi="http://www.w3.org/2001/XMLSchema-instance">
  <csw:TransactionSummary>
    <csw:totalInserted>1</csw:totalInserted>
  </csw:TransactionSummary>
</csw:TransactionResponse>
```

[Example 16–13](#) is a request to update the contributor value to Jane in the record where the current contributor value is John (that is, change the value from John to Jane).

Example 16–13 Update Request

```
<csw:Transaction service="CSW"
version="2.0.0"
xmlns:csw="http://www.opengis.net/cat/csw"
xmlns:ogc="http://www.opengis.net/ogc"
xmlns:dc="http://www.purl.org/dc/elements/1.1/">
  <csw:Update>
    <csw:RecordProperty>
      <csw:Name>/csw:Record/dc:contributor</csw:Name>
      <csw:Value>Jane</csw:Value>
    </csw:RecordProperty>

    <csw:Constraint version="2.0.0">
      <ogc:Filter>
        <ogc:PropertyIsEqualTo>
          <ogc:PropertyName>/csw:Record/dc:contributor</ogc:PropertyName>
          <ogc:Literal>John</ogc:Literal>
        </ogc:PropertyIsEqualTo>
      </ogc:Filter>
    </csw:Constraint>

  </csw:Update>
</csw:Transaction>
```

[Example 16–14](#) is the response from the request in [Example 16–13](#).

Example 16–14 Update Response

```
<csw:TransactionResponse xmlns:csw="http://www.opengis.net/cat/csw"
xmlns:dc="http://www.purl.org/dc/elements/1.1/"
xmlns:dct="http://www.purl.org/dc/terms/">
  <csw:TransactionSummary>
    <csw:totalUpdated>1</csw:totalUpdated>
  </csw:TransactionSummary>
</csw:TransactionResponse>
```

[Example 16–15](#) is a request to delete the record where the contributor value is equal to Jane.

Example 16–15 Delete Request

```
<csw:Transaction service="CSW"
  version="2.0.0"
  xmlns:csw="http://www.opengis.net/cat/csw"
  xmlns:dc="http://www.purl.org/dc/elements/1.1/"
  xmlns:ogc="http://www.opengis.net/ogc">
<csw:Delete typeName="csw:Record">
  <csw:Constraint version="2.0.0">
    <ogc:Filter>
      <ogc:PropertyIsEqualTo>
        <ogc:PropertyName>/csw:Record/dc:contributor</ogc:PropertyName>
        <ogc:Literal>Jane</ogc:Literal>
      </ogc:PropertyIsEqualTo>
    </ogc:Filter>
  </csw:Constraint>
</csw:Delete>
</csw:Transaction>
```

Example 16–16 is the response from the request in Example 16–15.

Example 16–16 Delete Response

```
<csw:TransactionResponse xmlns:csw="http://www.opengis.net/cat/csw"
  xmlns:dc="http://www.purl.org/dc/elements/1.1/"
  xmlns:dct="http://www.purl.org/dc/terms/">
  <csw:TransactionSummary>
    <csw:totalDeleted>1</csw:totalDeleted>
  </csw:TransactionSummary>
</csw:TransactionResponse>
```

16.4 Java API for CSW Administration

In addition to the PL/SQL APIs in the SDO_CSW_PROCESS package, you can use a Java API to publish and drop record types, and to grant and revoke access to record types and CSW metadata tables.

This section provides basic reference information about the methods in the `oracle.spatial.csw.CSWAdmin` class. The methods are presented in alphabetical order.

16.4.1 createXMLTableIndex method

The `createXMLTableIndex` method creates an index of XDB.XMLINDEX on record type instances. This method has the following format:

```
public static void createXMLTableIndex(
    OracleConnection conn,
    String typeNS,
    String typeName) throws SQLException;
```

`conn` is an Oracle Database connection for a user that has been granted the DBA role.

`typeNS` is the URL of the namespace of the record type.

`typeName` is the name of the record type.

16.4.2 deleteDomainInfo method

The `deleteDomainInfo` method deletes domain information related to the record type. This method has the following format:

```
public static void deleteDomainInfo(  
    OracleConnection conn,  
    int recordTypeId,  
    String parameterName) throws SQLException;
```

`conn` is an Oracle Database connection for a user that has been granted the DBA role.

`recordTypeId` is the ID of the record type.

`parameterName` is the name of the domain parameter to be deleted.

16.4.3 deleteRecordViewMap method

The `deleteRecordViewMap` method deletes information related to record view transformation. This method has the following format:

```
public static void deleteRecordViewMap(  
    OracleConnection conn,  
    String recordTypeNS,  
    String viewSrcName,  
    String targetTypeName,  
    String mapType) throws SQLException;
```

`conn` is an Oracle Database connection for a user that has been granted the DBA role.

`recordTypeNS` is the URL of the namespace of the record type.

`viewSrcName` is the name of the source of the record type.

`targetTypeName` is the name of the destination of the record type.

`mapType` is the map type (brief, summary, and so on).

16.4.4 disableVersioning method

The `disableVersioning` method disables versioning for a record type. This method has the following format:

```
public static void disableVersioning(  
    OracleConnection conn,  
    String rtNSUrl,  
    String rtName) throws SQLException;
```

`conn` is an Oracle Database connection for a user that has been granted the DBA role.

`rtNSUrl` is the URL of the namespace of the record type.

`rtName` is the name of the record type.

16.4.5 dropRecordType method

The `dropRecordType` method deletes a record type from the CSW repository. This method has the following format:

```
public static void dropRecordType(  
    OracleConnection conn,  
    String rtNSUrl,  
    String rtName) throws SQLException;
```

`conn` is an Oracle Database connection for a user that has been granted the DBA role.

`rtNSUrl` is the URL of the namespace of the record type.

`rtName` is the name of the record type.

16.4.6 dropXMLTableIndex method

The `dropXMLTableIndex` method drops an index of type `XDB.XMLINDEX` that was created on record type instances. This method has the following format:

```
public static void dropXMLTableIndex(
    OracleConnection conn,
    String typeNS,
    String typeName) throws SQLException;
```

`conn` is an Oracle Database connection for a user that has been granted the DBA role.

`typeNS` is the URL of the namespace of the record type.

`typeName` is the name of the record type.

16.4.7 enableVersioning method

The `enableVersioning` method enables versioning for a record type. This method has the following format:

```
public static void enableVersioning(
    OracleConnection conn,
    String rtNSUrl,
    String rtName) throws SQLException;
```

`conn` is an Oracle Database connection for a user that has been granted the DBA role.

`rtNSUrl` is the URL of the namespace of the record type.

`rtName` is the name of the record type.

16.4.8 getIsXMLTableIndexCreated method

The `getIsXMLTableIndexCreated` method returns a Boolean `TRUE` if an index of type `XDB.XMLINDEX` has been created on a record type, or a Boolean `FALSE` if such an index has not been created. This method has the following format:

```
public static boolean getIsXMLTableIndexCreated(
    OracleConnection conn,
    String typeNS,
    String typeName) throws SQLException;
```

`conn` is an Oracle Database connection for a user that has been granted the DBA role.

`typeNS` is the URL of the namespace of the record type.

`typeName` is the name of the record type.

16.4.9 getRecordTypeId method

The `getRecordTypeId` method returns the record type ID for a specified combination of namespace and record type. This method has the following format:

```
public static boolean getIRecordTypeId(
    OracleConnection conn,
    String typeNameSpace,
    String typeName) throws SQLException;
```

`conn` is an Oracle Database connection for a user that has been granted the DBA role.

`typeNameSpace` is the URL of the namespace of the record type.

typeName is the name of the record type.

16.4.10 grantMDAccessToUser method

The `grantMDAccessToUser` method grants access to the CSW metadata to a database user. This method has the following format:

```
public static void grantMDAccessToUser(
    OracleConnection conn,
    String userName) throws SQLException;
```

conn is an Oracle Database connection for a user that has been granted the DBA role.

userName is the name of the database user.

16.4.11 grantRecordTypeToUser method

The `grantRecordTypeToUser` method grants access to a record type to a database user. This method has the following format:

```
public static void grantRecordTypeToUser(
    OracleConnection conn,
    String typeNS,
    String typeName,
    String userName) throws SQLException;
```

conn is an Oracle Database connection for a user that has been granted the DBA role.

typeNS is the URL of the namespace of the record type.

typeName is the name of the record type.

userName is the name of the database user.

16.4.12 publishRecordType method

The `publishRecordType` method publishes a record type; that is, it registers metadata related to the record type. This method has the following formats:

```
public static void publishRecordType(OracleConnection conn,
    XMLType recordTypeMD) throws SQLException , CSWException;
```

```
public static void publishRecordType(OracleConnection conn,
    String typeNS,
    String typeName,
    ArrayList<String> idPaths,
    ArrayList<PathInfo> spatialPaths,
    ArrayList<PathInfo> tsPaths,
    XMLType schemaDoc,
    XMLType briefXSLPattern,
    XMLType summaryXSLPattern,
    XMLType dcmlXSLPattern,
    ArrayList<String> srsPaths,
    String idExtractorType,
    ArrayList<GeomMetaInfo> sdoMetaInfo,
    String srsNS, String srsNSAlias) throws SQLException ;
```

```
public static void publishRecordType(OracleConnection conn,
    String typeNS,
    String typeName,
    ArrayList<String> idPaths,
    ArrayList<PathInfo> spatialPaths,
```

```

        ArrayList<PathInfo> tsPaths,
        XMLType schemaDoc,
        XMLType briefXSLPattern,
        XMLType summaryXSLPattern,
        XMLType dcmiXSLPattern,
        ArrayList<String> srsPaths,
        String idExtractorType,
        ArrayList<GeomMetaInfo> sdoMetaInfo,
        String srsNS, String srsNSAlias,
        String rtXSDRefId,
        boolean genSpatialIndex,
        boolean setDomainInfo,
        Hashtable<String, ArrayList<String>> domainInfo,
        boolean setRecordViewMap,
        ArrayList<ArrayList<Object>> recordViewMap) throws SQLException ;

public static void publishRecordType(OracleConnection conn,
        String typeNS,
        String typeName,
        ArrayList<String> idPaths,
        ArrayList<PathInfo> spatialPaths,
        ArrayList<PathInfo> tsPaths,
        XMLType schemaDoc,
        XMLType briefXSLPattern,
        XMLType summaryXSLPattern,
        XMLType dcmiXSLPattern,
        ArrayList<String> srsPaths,
        String idExtractorType,
        ArrayList<GeomMetaInfo> sdoMetaInfo,
        String srsNS, String srsNSAlias,
        String rtXSDRefId,
        boolean genSpatialIndex,
        boolean setDomainInfo,
        Hashtable<String, ArrayList<String>> domainInfo,
        boolean setRecordViewMap,
        ArrayList<ArrayList<Object>> recordViewMap,
        ArrayList<PathInfo> numPaths,
        ArrayList<PathInfo> idxPaths,
        ArrayList<String[]> idxPathTypes,
        boolean genXMLIndex) throws SQLException ;

public static void publishRecordType(OracleConnection conn,
        String typeNS,
        String typeName,
        ArrayList<String> idPaths,
        ArrayList<PathInfo> spatialPaths,
        ArrayList<PathInfo> tsPaths,
        XMLType schemaDoc,
        XMLType briefXSLPattern,
        XMLType summaryXSLPattern,
        XMLType dcmiXSLPattern,
        ArrayList<String> srsPaths,
        String idExtractorType, ArrayList<GeomMetaInfo> sdoMetaInfo,
        String srsNS, String srsNSAlias,
        String rtXSDRefId,
        boolean genSpatialIndex,
        boolean setDomainInfo,
        Hashtable<String, ArrayList<String>> domainInfo,
        boolean setRecordViewMap,
        ArrayList<ArrayList<Object>> recordViewMap,

```

```
        ArrayList<PathInfo> numPaths,  
        ArrayList<PathInfo> idxPaths,  
        ArrayList<String[]> idxPathTypes,  
        boolean genXMLIndex,  
        boolean isGML3) throws SQLException ;  
  
public static void publishRecordType(OracleConnection conn,  
    String typeNS,  
    String typeName,  
    ArrayList<String> idPaths,  
    ArrayList<PathInfo> spatialPaths,  
    ArrayList<PathInfo> tsPaths,  
    XMLType schemaDoc,  
    XMLType briefXSLPattern,  
    XMLType summaryXSLPattern,  
    XMLType dcmlXSLPattern,  
    ArrayList<String> srsPaths,  
    String idExtractorType,  
    ArrayList<GeomMetaInfo> sdoMetaInfo,  
    String srsNS, String srsNSAlias,  
    String rtXSDRefId,  
    boolean genSpatialIndex,  
    boolean setDomainInfo,  
    Hashtable<String, ArrayList<String>> domainInfo,  
    boolean setRecordViewMap,  
    ArrayList<ArrayList<Object>> recordViewMap,  
    ArrayList<PathInfo> numPaths,  
    ArrayList<PathInfo> idxPaths,  
    ArrayList<String[]> idxPathTypes,  
    boolean genXMLIndex,  
    boolean isGML3,  
    CollectionPathInfo collPathInfo) throws SQLException;  
  
public static void publishRecordType(OracleConnection conn,  
    String typeNS,  
    String typeName,  
    ArrayList<String> idPaths,  
    ArrayList<PathInfo> spatialPaths,  
    ArrayList<PathInfo> tsPaths,  
    XMLType schemaDoc,  
    XMLType briefXSLPattern,  
    XMLType summaryXSLPattern,  
    XMLType dcmlXSLPattern,  
    ArrayList<String> srsPaths,  
    String idExtractorType,  
    ArrayList<GeomMetaInfo> sdoMetaInfo,  
    String srsNS, String srsNSAlias,  
    String rtXSDRefId,  
    boolean genSpatialIndex,  
    boolean setDomainInfo,  
    Hashtable<String, ArrayList<String>> domainInfo,  
    boolean setRecordViewMap,  
    ArrayList<ArrayList<Object>> recordViewMap,  
    ArrayList<PathInfo> numPaths,  
    ArrayList<PathInfo> idxPaths,  
    ArrayList<String[]> idxPathTypes,  
    boolean genXMLIndex,  
    boolean isGML3,  
    CollectionPathInfo collPathInfo,  
    boolean hasMultipleSRSNS) throws SQLException;
```

`conn` is an Oracle Database connection for a user that has been granted the DBA role.

`recordTypeMD` is the record type registration metadata. This metadata must conform to the `recordTypeMD` element definition as specified in the `wstype_md.xsd` file. Examples of record type path registration metadata XML are provided in `rt_metadata1.xml` and `rt_metadata2.xml`. These files are included in the `ws_client.jar` demo file (described in [Section 10.4](#)) under the `src/data/` path. For information about using the examples to publish record types, see the `Readme.txt` file, which is included in `ws_client.jar` under the `src/` path.

`typeNS` is the URL of the namespace of the record type.

`typeName` is the name of the record type.

`idPaths` is a list of record ID path elements where each element is a String.

`spatialPaths` is a list of spatial paths in the record type. It is an `ArrayList` of class `oracle.spatial.ws.PathInfo`, which is described in [Section 16.4.12.1](#).

`tsPaths` is a list of time-related paths in the record type (for example, `date`, `dateTime`, `gYear`, `gMonth`, `gDay`, `gMonthDay`, and `gYearMonth`). It is an `ArrayList` of class `oracle.spatial.ws.PathInfo`, which is described in [Section 16.4.12.1](#).

`schemaDoc` is the XML schema definition (XSD) of the record type.

`briefXSLPattern` is the XSLT mapping for transforming the record structure from full to brief format.

`summaryXSLPattern` is the XSLT mapping for transforming the record structure from summary to brief format.

`dcmiXSLPattern` is the XSLT mapping for transforming the record structure from `dcmi` to brief format.

`srsPaths` is a list of paths representing spatial reference system information.

`idExtractorType` is Identifier extractor method information (`XPATH`, `USER_FUNC`, or `NONE`). `XPATH` means that the record identifier will be extracted using an XPath as specified in the `idPaths` parameter. `USER_FUNC` means that the record identifier will be extracted by a user-defined function invocation, as specified in the `idPaths` parameter, to which the entire record document instance will be passed. `NONE` means that the record identifier will be a system-generated identifier.

`sdoMetaInfo` is the spatial metadata information for spatial paths. It is an `ArrayList` of class `oracle.spatial.ws.GeomMetaInfo`, which is described in [Section 16.4.12.1](#).

`srsNS` is the user-defined namespace of the spatial reference system (coordinate system) associated with the data in the spatial paths.

`srsNSAlias` is the namespace alias of the spatial reference system (coordinate system) associated with the data in the spatial paths.

`rtXSDRefId` is the group record type XML schema definition file name (as a string), for cases where multiple record types are defined in a single XSD file. This parameter is used to store the group XSD definition once in the CSW metadata, and then refer to it from multiple record types whose schema definitions are present in the group record type XSD file.

`genSpatialIndex` is a Boolean value: `TRUE` causes a spatial index to be created on the record type at type creation time; `FALSE` does not cause a spatial index to be created.

`setDomainInfo` is a Boolean value: `TRUE` causes domain information for this record type to be set at type creation time; `FALSE` does not cause domain information for this record type to be set.

`domainInfo` is domain information.

`setRecordViewMap` is a Boolean value: `TRUE` causes the record view transformation map to be set at type creation time; `FALSE` does not cause the record view transformation map to be set.

`recordViewMap` is the record view transformation map information (brief to full, summary to full, and dcmi to full). It is of type `ArrayList<ArrayList<Object>>` where the content of each `ArrayList<Object>` is: `Object[0] = (String) recordTypeNS`, `Object[1] = (String) viewSrcName`, `Object[2] = (String) targetTypeNS`, `Object[3] = (oracle.xdb.XMLType) mapInfo`, `Object[4] = (String) mapType`

`numPaths` is a list of numeric (NUMBER, INTEGER, and so on) related paths in the record type. It is an `ArrayList` of class `oracle.spatial.ws.PathInfo`, which is described in [Section 16.4.12.1](#).

`idxPaths` is the index path list. It is list of paths on which to create an index of type `XDB.XMLINDEX` when that index is created. It is an `ArrayList` of class `oracle.spatial.ws.PathInfo`, which is described in [Section 16.4.12.1](#).

`idxPathTypes` specifies information about each index path, where each element of `string[3]` contains the following: `string[0]` is the type name, `string[1]` is the type format (such as the type length), and `string[2]` specifies whether a Btree or unique index, or no index, should be created (`CSWAdmin.BTREE`, `CSWAdmin.UNIQUE`, or null).

`genXMLIndex` is a Boolean value: `TRUE` causes an index of type `XDB.XMLINDEX` to be created on the document-based record type; `FALSE` does not cause an index of type `XDB.XMLINDEX` to be created on the document-based record type. If you choose not to create the index now, you can create it later using the `createXMLTableIndex` method (described in [Section 16.4.1](#)).

`isGML3` is a Boolean value: `TRUE` means that the geometries inside instances of this record type are GML3.1.1 compliant; `FALSE` means that the geometries inside instances of this record type are GML 2.1.2 compliant.

`collPathInfo` is spatial collection path information.

`hasMultipleSRSNS` is a Boolean value: `TRUE` means that this record type refers to multiple user-defined spatial reference system namespaces; `FALSE` means that this record type does not refer to multiple user-defined spatial reference system namespaces.

16.4.12.1 Related Classes for `publishRecordType`

This section describes some classes used in the definition of parameters of the [publishRecordType method](#).

`oracle.spatial.ws.PathElement` is a Java class that contains a pair of `String` objects: the `PathElement` namespace and the `PathElement` name. This class includes the `getValue()` method, which returns a string format of the `PathElement` object. This class has the following format:

```
public class PathElement {
// Set namespace and name information for a PathElement.
    public void set(String ns, String name);
//Get a string value for the PathElement object.
    public String getValue() ;
}
```



```
}

```

`oracle.spatial.ws.Path` is a Java class that contains an ordered list of `PathElement` objects that constitute the path. For example, if an XPath is `myns:A/myns:B`, then `myns:A` and `myns:B` are `PathElement` objects. This class includes the `getValue()` method, which returns a string format of the `Path` object. This class has the following format:

```
public class Path {
//Add a PathElement.
    public void add(PathElement p) ;
//Get a string Value for the Path object.
    public String getValue() ;
}

```

`oracle.spatial.ws.PathInfo` is a container class that contains information about a path or list of paths, including their association and metadata information. This class has the following format:

```
public class PathInfo {

// Set number of occurrences for the Path. Default value is 1. Number of
// occurrences > 1 in case of arrays.
    public void setNumOfOccurrences(int i) ;

// Get number of occurrences for the Path.
    public int getNumOfOccurrences();

// Add a path, in case PathInfo has multiple paths associated via a
// choice association
    public void addPath(Path p) ;

// Add path type information. This is relevant for time-related Paths
// (for example, date, dateTime, gDay, gMonth, gYear, gMonthDay,
// gYearMonth, duration, or time).
    public void addPathType(String t) ;

// Add a PathInfo type. This can be PathInfo.CHOICE or
// PathInfo.DEFAULT or PathInfo.COLLECTION.
// PathInfo.CHOICE - means that the list of paths in this PathInfo are
// related to each other via choice association. For example, we may have
// a list of Spatial Paths, which are associated with one another via choice.
// So, only one of these path can occur in a feature instance/document.
// PathInfo.COLLECTION - means the list of paths in this PathInfo are part
// of a collection (currently spatial collections are
// supported) which will be indexed.
// Default value is PathInfo.DEFAULT for one Path or a finite array Paths.
// @param t PathInfo type information. PathInfo.CHOICE or
// PathInfo.DEFAULT or PathInfo.COLLECTION
    public void addPathInfoType(int t) ;

// Returns a string representation for PathInfo content.
    public String getPathContent() ;

// Returns Path type information (for example, date, dateTime, gDay, gMonth,
// gYear, gMonthDay, gYearMonth, duration, or time).
    public String getPathType() ;

// Returns a string representation for PathInfo path content.
// param i The index of the path in the PathInfo whose path content needs to

```

```
// be returned
// @return a string representation for PathInfo path content
    public String getCollectionPathContent(int i);

// Returns number of paths in the PathInfo.
// @return number of paths in the PathInfo which is of type PathInfo.COLLECTION
// if PathInfo is not of type PathInfo.COLLECTION returns -1
    public int getCollectionPathContentSize();
}
```

`oracle.spatial.ws.CollectionPathInfo` is a container class that contains information about a collection of `PathInfo` objects. Each `PathInfo` object in this collection, represents a group of spatial paths that will be indexed and searched on. This class will be used to register paths referring to spatial collection-based content in feature and record types. This class has the following format:

```
public class CollectionPathInfo {

    /**
     * Add a PathInfo.
     * @param p PathInfo to be added
     * @param g geometry related metadata for PathInfo to be added
     */
    public void addPathInfo(PathInfo p, GeomMetaInfo g) ;

    /**
     * Get a PathInfo.
     * @param i index of the PathInfo to be retrieved
     */
    public PathInfo getPathInfo(int i) ;

    /**
     * Get geometry related metadata for a certain PathInfo.
     * @param i index of the PathInfo whose geomMetaInfo is to be retrieved
     */
    public GeomMetaInfo getGeomMetaInfo(int i) ;

    /**
     * Get all PathInfo objects in this CollectionPathInfo.
     */
    public ArrayList<PathInfo> getPathInfos() ;
}
```

`oracle.spatial.ws.GeoMetaInfo` is a class that contains dimension-related information corresponding to a spatial path in a record type. This information includes the dimension name, the lower and upper bounds, the tolerance, and the coordinate system (SRID). This class has the following format:

```
public class GeoMetaInfo {

    // Default constructor. Creates a GeoMetaInfo object with number of
    // dimensions equal to 2.
    public GeoMetaInfo() ;

    // Creates a GeoMetaInfo object of a specified number of dimensions.
    // Parameter numofDimensions is the number of dimensions represented
    // in the GeoMetaInfo object.
    // Note: max number of dimensions supported is 4.
    public GeoMetaInfo(int numofDimensions) throws
        ArrayIndexOutOfBoundsException ;
}
```

```
//Set Dimension Name.
// Parameter index represents the dimension index which needs to be set.
// Parameter val is dimension name value.
    public void setDimName(int index, String val) throws
        ArrayIndexOutOfBoundsException ;

// Set Dimension Lower Bound.
// Parameter index represents the dimension index which needs to be set.
// Parameter val is dimension lower bound value.
    public void setLB(int index, double val) throws
        ArrayIndexOutOfBoundsException ;

// Set Dimension Upper Bound
// Parameter index represents the dimension index which needs to be set.
// Parameter val is dimension upper bound value
    public void setUB(int index, double val) throws
        ArrayIndexOutOfBoundsException ;

// Set Dimension tolerance value.
// Parameter index represents the dimension index which needs to be set.
// Parameter val is dimension tolerance value.
    public void setTolerance(int index, double val) throws
        ArrayIndexOutOfBoundsException ;

// Set Coordinate Reference System Identifier
    public void setSRID (int val) ;

// Get dimension Name.
// Parameter index represents the dimension index whose name needs to be
// returned. This method returns the dimension name for the given index.
    public String getDimName(int index) throws
        ArrayIndexOutOfBoundsException ;

// Get dimension lower bound.
// Parameter index represents the dimension index whose lower bound needs
// to be returned.
// This method returns the lower bound for the given index.
    public double getLB(int index) throws ArrayIndexOutOfBoundsException ;

// Get dimension upper bound.
// Parameter index represents the dimension index whose upper bound needs
// to be returned.
// This method returns the upper bound for the given index.
    public double getUB(int index) throws ArrayIndexOutOfBoundsException ;

// Get dimension tolerance.
// Parameter index represents the dimension index whose tolerance needs
// to be returned.
// This method returns the tolerance value for the given index.
    public double getTolerance(int index) throws
        ArrayIndexOutOfBoundsException ;

// Get coordinate system (spatial reference system) identifier.
    public int getSRID () ;

// Get number of dimensions represented by this GeomMetaInfo object.
    public int getNumOfDimensions() ;

// Sets the spatial index dimension parameter. By default it is 2.
// return Coordinate Reference System Identifier value
```

```
        public int setSpatialIndexDimension(int d) ;

// Get the spatial index dimension parameter.
// return number of dimensions
        public int getSpatialIndexDimension() ;

// Sets the user spatial srs namespace referred to by this GeomMetaInfo object.
// Needs to be specified if multiple srs namespace are referred to within
// the same feature or record type.
        public void setSRSNS(String s) ;

// Gets the user defined spatial srs namespace referred to by
// this GeomMetaInfo object.
        public String getSRSNS() ;

// Sets the user defined spatial srs namespace alias referred to
// by this GeomMetaInfo object.
        public void setSRSNSAlias (String s) ;

// Gets the user defined spatial srs namespace alias
// referred to by this GeomMetaInfo object.
        public String getSRSNSAlias () ;
    }
```

16.4.13 registerTypePluginMap method

The `registerTypePluginMap` method registers a plugin for processing and extracting spatial content for a record type. This method has the following format:

```
public static boolean registerTypePluginMap(
    OracleConnection conn,
    String typeNamespace,
    String typeName,
    String packageName) throws SQLException;
```

`conn` is an Oracle Database connection for a user that has been granted the DBA role.

`typeNS` is the URL of the namespace of the record type.

`typeName` is the name of the record type.

`packageName` is the name of the PL/SQL package object for the plugin (for example, `scott.my_plugin_pkg`).

16.4.14 revokeMDAccessFromUser method

The `revokeMDAccessFromUser` method revokes access to the CSW metadata from a database user. This method has the following format:

```
public static void revokeMDAccessFromUser(
    OracleConnection conn,
    String usrName) throws SQLException;
```

`conn` is an Oracle Database connection for a user that has been granted the DBA role.

`usrName` is the name of the database user.

16.4.15 revokeRecordTypeFromUser method

The `revokeRecordTypeFromUser` method revokes access to a record type from a database user. This method has the following format:

```
public static void revokeRecordTypeFromUser(
    OracleConnection conn,
    String typeNS,
    String typeName,
    String usrName) throws SQLException;
```

`conn` is an Oracle Database connection for a user that has been granted the DBA role.

`typeNS` is the URL of the namespace of the record type.

`typeName` is the name of the record type.

`usrName` is the name of the database user.

16.4.16 setCapabilitiesInfo method

The `setCapabilitiesInfo` method populates the capabilities related information. (For information about capabilities documents, see [Section 16.2.1](#).) This method has the following format:

```
public static void setCapabilitiesInfo(OracleConnection conn,
    XMLType capabilitiesTemplate) throws SQLException;
```

`conn` is an Oracle Database connection for a user that has been granted the DBA role.

`capabilitiesTemplate` is the Catalog services capabilities document.

16.4.17 setDomainInfo method

The `setDomainInfo` method sets domain information related to the record type. This method has the following format:

```
public static void setDomainInfo(OracleConnection conn,
    int recordTypeId,
    String propertyName,
    String parameterName,
    ArrayList<String> values) throws SQLException;
```

`conn` is an Oracle Database connection for a user that has been granted the DBA role.

`recordTypeId` is the ID of the record type.

`propertyName` is the name of a domain property.

`parameterName` is the name of a domain parameter.

`values` specifies values for the domain parameter.

16.4.18 setRecordViewMap method

The `setRecordViewMap` method populates information related to record view transformation (for example, from `BriefRecord` to `Record`). This method has the following format:

```
public static void setRecordViewMap(OracleConnection conn,
    String recordTypeNS,
    String viewSrcName,
    String targetTypeNS,
    oracle.xdb.XMLType mapInfo,
    String mapType) throws SQLException;
```

`conn` is an Oracle Database connection for a user that has been granted the DBA role.

`recordTypeNS` is the URL of the namespace of the record type.

`viewSrcName` is the name of the source of the record type.

`targetTypeName` is the name of the destination of the record type.

`mapInfo` is the XSLT definition of the mapping.

`mapType` is the map type (brief, summary, and so on).

16.4.19 setXMLTableIndexInfo method

The `setXMLTableIndexInfo` method updates the `XMLTableIndex` index information for a record type, with the option of creating the index. This method has the following format:

Note: If the `XMLTableIndex` index already exists, you must drop it (using the [dropRecordType](#) method) before you call the `setXMLTableIndexInfo` method.

```
public static void setXMLTableIndexInfo(OracleConnection conn,
    String typeNS,
    String ftName,
    ArrayList<PathInfo> idxPaths,
    ArrayList<String[]> idxPathTypes,
    boolean genXMLIndex) throws SQLException , CSWException;
```

`conn` is an Oracle Database connection for a user that has been granted the DBA role.

`typeNS` is the URL of the namespace of the record type.

`ftName` is the name of the record type.

`idxPaths` is the index path list. It is list of paths on which to create an index of type `XMLTABLEINDEX` when that index is created. It is an `ArrayList` of class `oracle.spatial.ws.PathInfo`, which is described in [Section 16.4.12.1](#).

`idxPathTypes` specifies information about each index path, where each element of `string[3]` contains the following: `string[0]` is the type name, `string[1]` is the type format (such as the type length), and `string[2]` specifies whether a Btree or unique index, or no index, should be created (`CSWAdmin.BTREE`, `CSWAdmin.UNIQUE`, or null).

`genXMLIndex` is a Boolean value: `TRUE` causes an index of type `XDB.XMLINDEX` to be created on the record type; `FALSE` does not cause an index of type `XDB.XMLINDEX` to be created on the record type. If you choose not to create the index now, you can create it later using the `createXMLTableIndex` method (described in [Section 16.4.1](#)).

Security Considerations for Spatial Web Services

For Spatial Web services, you will want to make the connection to the database as secure as possible. Security in this context includes the following considerations:

- Confidentiality: a guarantee that no third party can intercept and decrypt messages between a user and the server
- Authenticity: a guarantee that no third party can convincingly impersonate another user when connected to the server
- Integrity: a guarantee that no third party can alter a message between a user and the server without the alteration being detected

After authentication reliably determines each user's identity, users also expect flexible and fine-grained authorization, limiting their access to data and features based on their identity and any privileges associated with that identity. However, many current XML and SOAP interfaces do not adequately cover these aspects of security.

This chapter includes the following major sections:

- [Section 17.1, "User Management"](#)
- [Section 17.2, "Access Control and Versioning"](#)
- [Section 17.3, "Configuring Web Services for Security"](#)
- [Section 17.4, "Interfaces for Spatial Web Services"](#)

See also the `wscclient.jar` demo file (described in [Section 10.4](#)) for instructions and samples related to security with Spatial Web services.

17.1 User Management

For Spatial Web services, several forms of user management are available, affecting how administrators manage external users (that is, the users making SOAP/XML requests) and database users, as well as how users' credentials are controlled (and thus which data and Web service features these users can access).

In the database, a user can be either a database/enterprise user (managed by the system) or an application user (managed in a table). In addition, OC4J might share the user definition of an enterprise user, or it might define an LDAP-managed user separate from any database user (such as using the same name as an existing database user but not necessarily the same authentication as that database user).

Generally, a user will make SOAP requests, for example, by providing the user name John and the authentication `secret`. In this scenario, John must be an OC4J user.

(The administrator can use LDAP, LDAP/XML, and other methods for OC4J user management.)

User management in the database is linked to identity propagation, which is described in [Section 17.1.1](#).

17.1.1 Identity Propagation to the Database

The SpatialWS service in OC4J will propagate the user's identity to the database through one of several options, which are linked to user management in the database, and thus provide administrators with flexibility in controlling user authorization and auditing. The following identity propagation options are available:

- **Proxy authentication:** Uses a JDBC connection to the database user through a proxy user. For example, user John in the database and user John in OC4J might be set up independently, perhaps even with different passwords; or user John might be set up as an enterprise user shared by OC4J and the database; or database user John can be set up for use through proxy authentication but not through a direct SQL connection.
- **Application user management:** Manages users in a database table as opposed to through database users, providing more flexibility for administrators. With this approach, when using a virtual private database (see [Section 17.2.1](#)), you cannot determine the user's identity by entering `SELECT USER FROM DUAL`, but must instead query the system context, as follows:

```
SELECT SYS_CONTEXT('APP_CTX', 'APP_USER_ID') FROM DUAL;
```

For example, user John in the database and user John in OC4J might be set up independently, perhaps even with different passwords; or OC4J can be configured to share the application users in the database table.

- **Single application user:** Uses a single application user for connections to the database. This approach is acceptable if applications do not need to distinguish among specific users, as long as they are authorized to use Spatial Web services. In this case, the specific users use the same credentials of the single application user, and they are not separately audited.

To specify the identity propagation option, insert one of the following subelements in the `<Proxy_management>` element in the `WSConfig.xml` file (described in [Section 10.3](#)):

- `<Proxy_authentication/>` to specify proxy authentication
- `<Application_user_management/>` to specify application user management
- `<Fixed_app_user/>` to use a single application user

17.1.2 Caching and User Administration

Any handler in the Spatial Web services framework can choose to use caching in OC4J. For example, WFS caches feature tables. The OC4J cache must comply with any authorization restrictions set up in the database, such as the use of a virtual private database (VPD). It is not feasible to replicate the entire database authorization framework locally; therefore, you must verify the applicable authorization restrictions with the database for each query.

For WFS, this means that queries must be by ID values only rather than by actual data values in other columns. For example, a query might specify `SELECT id FROM...` instead of `SELECT col1, col2 FROM...` In such cases, the actual data is already

cached, and the query just verifies row-level authorization. This approach also usually results in a performance benefit, especially for large data records (as is often the case with spatial data).

However, this approach will not work for some forms of column-level VPDs. For example, column-level VPDs might be configured so that user John can see only generalized geometries, whereas user Jane can see the original detailed geometries. Both users access the same data records, but for John the geometry column level gets "obfuscated," which in this example might mean a geometry generalization. As another example, obfuscation might make Social Security numbers visible only to authorized users, but showing the obfuscated value `*****` to other users.

For the Spatial network data model, caching does not verify authorization restrictions (due to performance considerations related to network query patterns). Therefore, the network data model uses the single application user option for identity propagation (see [Section 17.1.1](#)), which limits an administrator's options for controlling the authorization of users.

17.2 Access Control and Versioning

Authorization and versioning are primarily performed in the database rather than in OC4J, although the administrator can configure OC4J to perform some authorization restrictions. Oracle Database enables common grants on select, insert, and update operations, as well as a virtual private database (VPD), to be configured. Workspace Manager operations are also supported.

As mentioned in [Section 17.1.2](#), any caching in OC4J should be consistent with the database configuration. However, if the caching is not consistent, you should use the single application user approach described in [Section 17.1.1](#), because then it will not be an issue that all human users of the application will be able to see the same data.

17.2.1 Virtual Private Databases

Note: OpenLS mapping and routing services cannot operate with virtual private databases (VPDs) or with other forms of user-specific authorization (such as granting SELECT privilege on a table to a specified user).

An administrator can restrict users' access by implementing virtual private databases (VPDs). When proxy authentication or application user management is used for identity propagation (see [Section 17.1.1](#)), SOAP requests are executed in the context of VPD policies for the current user, as specified in the WSS section of each SOAP request.

When a single application user is used for identity propagation, SOAP requests are executed in the context of the generic single user, making all SOAP requests fundamentally anonymous to the database. (OC4J will still recognize the user by the user name in the WSS section of the SOAP message, and thus OC4J could be configured for auditing; however, the database does not share that knowledge of the user name.)

17.2.2 Workspace Manager

You can execute any SOAP request in the context of a workspace by specifying the workspace ID in an `<SdoRequest>` element, as in the following example:

```

<mdsys:SdoRequest xmlns:mdsys="http://www.oracle.com/2006/mdsys"
  xmlns:xsi="http://www.w3.org/2001/XMLSchema-instance">
  <mdsys:SdoRequestHeader workspace_id="OlsWorkspace"/>
  <mdsys:SdoRequestBody>
    <XLS ...>
  </XLS>
  </mdsys:SdoRequestBody>
</mdsys:SdoRequest>

```

See also `oracle.spatial.ws.svrproxy.TestYPWithWorkspace.java` under `src/oracle/spatial/ws/svrproxy/` in the `wsclient.jar` demo file (described in [Section 10.4](#)).

17.3 Configuring Web Services for Security

After you deploy the `.ear` file, you must configure it. The general configuration includes the following files, but excludes any service-specific setup, such as the WFS-specific portions of the `WSConfig.xml` file:

- `data-sources.xml` contains the database connection for each service (Catalog, OpenLS, WFS, and so on). For example:

```

<?xml version = '1.0' encoding = 'windows-1252'?>
. . .
<native-data-source
  name="jdev-connection-NdmProxyConnection"
  jndi-name="jdbc/NdmProxyConnectionCoreDS"
  url="jdbc:oracle:thin:@server.com:port:sid"
  user="usr"
  password="password"
  data-source-class="oracle.jdbc.pool.OracleDataSource"/>
. . .
</data-sources>

```

- `WSConfig.xml` contains, beside WFS-specific parameters, the definition of handlers: name, implementation, and user management. For example:

```

<Handlers>
  <OpenLS>
    <JavaClass>oracle.spatial.ws.openls.OpenLsHandler</JavaClass>
    <Anonymous_xml_user>SpatialWsXmlUser</Anonymous_xml_user>
    <Proxy_management>
      <Proxy_authentication/>
    </Proxy_management>
  </OpenLS>
  . . .
  <Network>
    <JavaClass>oracle.spatial.network.xml.NetworkWSHandler</JavaClass>
    <Proxy_management>
      <Fixed_app_user/>
    </Proxy_management>
  </Network>
  . . .
</Handlers>

```

The `data-sources.xml` file contains a database connection for each services handler, such as WFS. There are three scenarios, based on the method of user identity propagation (described in [Section 17.1.1](#)):

- Proxy authentication: The connection specified refers to the proxy user, which is different from the actual SOAP user.
- Application user management: The connection specified refers to the proxy user, connected as the user to which the system context is set.
- Single application user: The connection specified refers to the final user (APP_USER). There is no proxying, no changing of the system context, and no reconnecting as a different user.

The `WSConfig.xml` file includes a part that declares handlers:

- `<JavaClass>`, the first parameter, specifies the implementation of the service handler. This Java class implements the interface `oracle.spatial.ws.SpatialWSHandler`. This implementing class can be made available to OC4J in a shared library, specified in the `server.xml` file. For example:

```
<shared-library name="sdows" version="1.0">
  <code-source path="*" />
  <import-shared-library name="oracle.xml" />
  <import-shared-library name="oracle.jdbc" />
</shared-library>
. . .
</application-server>
```

The administrator must give the `SpatialWS.ear` file access to that shared library. This can be done globally in `application.xml`, as in the following example:

```
<imported-shared-libraries>
. . .
  <import-shared-library name="sdows" />
</imported-shared-libraries>
</orion-application>
```

- `<Anonymous_xml_user>`, the second parameter, specifies the database identity of users connecting through the simple non-SOAP XML interface as opposed to the SOAP interface. (For more information, see [Section 17.4.2](#).)
- `<Proxy_management>`, the third parameter, specifies method of propagating the user's identity to the database. Possible values are `<Proxy_authentication>`, `<Application_user_management>`, and `<Fixed_app_user>`. The most typical selection will probably be `<Proxy_authentication>`.

In addition, when deploying and configuring the `.ear` file, be sure to check for any security-related information in the material about deploying a J2EE application (EAR) in *Oracle Containers for J2EE Configuration and Administration Guide*, as well as the information about configuring a secure website in OC4J.

17.3.1 Adding Spatial Service Handlers

By default, Spatial Web services include support for CSW, OpenLS, and WFS. However, you can add support for additional service handlers by implementing and deploying an interface for each desired handler.

To include support for a service handler, implement the interface `oracle.spatial.ws.SpatialWSHandler` and deploy it into a `.jar` file. The implementation contains the following function that determines whether the current request is meant for this service:

```
public boolean canHandle(Element request)
```

To deploy the interface, perform the following actions. (You can perform the steps in any order.)

1. Make the .jar file accessible to OC4J. The administrator might do so by creating a new shared library (see the information in [Section 17.3](#) about updating `server.xml` and `application.xml`), or by adding the .jar file to the existing shared `sdows` library (a quick approach).
2. Declare the service in a `<Handlers>` element in the `WSConfig.xml` file, which includes specifying the implementation class name. (See the example for the OpenLS and Network handlers in [Section 17.3](#).)
3. Declare the data source in a `<native-data-source>` element in the `data-sources.xml` file, which includes specifying the connection JNDI name. (See the example for `jdbc/NdmProxyConnectionCoreDS` in [Section 17.3](#).) The implementation contains the following function that determines the connection JNDI name:

```
public String getConnectionJndiName()
```

This name must match the JNDI name specified in the `data-sources.xml` file.

17.4 Interfaces for Spatial Web Services

Spatial Web services can be accessed through different interfaces, each having implications for security. For all services, a SOAP/WSS interface is available, as well as a simple XML (non-SOAP) interface. For OpenLS, there also is a PL/SQL interface, because the OpenLS implementation itself is in PL/SQL.

17.4.1 SOAP/WSS Interface

The SOAP/WSS interface is probably the best choice in most cases for accessing Spatial Web services. This interface offers the end-to-end security of WSS, and integration with other Web services. However, a simple XML interface is also available as an alternative, as explained in [Section 17.4.2](#).

The default URL for the SOAP/WSS interface has the following form:

```
http://hostname:port/SpatialWS-SpatialWS-context-root/SpatialWSSoapHttpPort
```

17.4.2 XML (Non-SOAP) Interface

Sometimes you might prefer the simple non-SOAP XML interface to Spatial Web services. Specifically, this XML interface:

- Integrates easily with existing software. For example, it is easier to make JMeter connect to an XML servlet than to SOAP, particularly when WSS is used.
- Provides better performance through lower overhead. SOAP adds overhead for parsing and for encryption/signing, due to WSS. (However, the overhead is reduced if the XML service is accessed through SSL.)

The default URL for the non-SOAP XML interface has the following form:

```
http://hostname:port/SpatialWS-SpatialWS-context-root/SpatialWSXMLServlet
```

This XML interface is set up to not expect a user identity or authentication. Consequently, for XML requests, the SpatialWS service will connect to the database

under a generic identity, common to all XML users. This identity is defined in the `WSConfig.xml` file as `<Anonymous_xml_user>`.

This approach is similar to using the `<fixed_app_user>` option in the `WSConfig.xml` file, which causes OC4J to keep the user anonymous as far as the database is concerned. That is, OC4J could still perform auditing or JAAS-based authorization restrictions, but database-side user authorization and auditing are limited. However, for the non-SOAP XML interface, the user is anonymous even to OC4J.

17.4.3 PL/SQL Interface (OpenLS Only)

OpenLS has a PL/SQL interface, in addition to SOAP and non-SOAP XML interfaces. If you connect through SQL and use the PL/SQL API directly, the following security considerations are different than for the apply differently than for the SOAP and non-SOAP XML APIs:

- Proxy authentication and application user management are not required, because the connection is directly between the user and the database.
- OC4J authentication, authorization, and caching are not required, because OC4J is not involved.

17.4.4 Level of Security, by Interface

The PL/SQL interface provides the same level of security as the SOAP interface, but in different environments. However, the non-SOAP XML provides a lower security (less secure) level, mainly because users remain anonymous to the database (except as the generic `APP_USER`). The non-SOAP XML interface could be used with SSL and user authentication and authorization, thus enabling identity propagation to the database; however, this would probably outweigh any perceived advantages to choosing the simple XML interface option.

If you do not need the non-SOAP XML interface and want to make it unavailable for use, you can deactivate the servlet at a URL in the following form:

```
http://hostname:port/SpatialWS-SpatialWS-context-root/SpatialWSXMLServlet
```

Part III

Reference Information

This document has the following parts:

- [Part I](#) provides conceptual and usage information about Oracle Spatial.
- [Part II](#) provides conceptual and usage information about Oracle Spatial Web services.
- Part III provides reference information about Oracle Spatial operators, functions, and procedures.
- [Part IV](#) provides supplementary information (appendixes and a glossary).

Part III contains the following chapters with reference information:

- [Chapter 18, "SQL Statements for Indexing Spatial Data"](#)
- [Chapter 19, "Spatial Operators"](#)
- [Chapter 20, "Spatial Aggregate Functions"](#)
- [Chapter 21, "SDO_CS Package \(Coordinate System Transformation\)"](#)
- [Chapter 22, "SDO_CSW_PROCESS Package \(CSW Processing\)"](#)
- [Chapter 23, "SDO_GCDR Package \(Geocoding\)"](#)
- [Chapter 24, "SDO_GEOM Package \(Geometry\)"](#)
- [Chapter 25, "SDO_LRS Package \(Linear Referencing System\)"](#)
- [Chapter 26, "SDO_MIGRATE Package \(Upgrading\)"](#)
- [Chapter 27, "SDO_OLS Package \(OpenLS\)"](#)
- [Chapter 28, "SDO_PC_PKG Package \(Point Clouds\)"](#)
- [Chapter 29, "SDO_SAM Package \(Spatial Analysis and Mining\)"](#)
- [Chapter 30, "SDO_TIN_PKG Package \(TINs\)"](#)
- [Chapter 31, "SDO_TUNE Package \(Tuning\)"](#)
- [Chapter 32, "SDO_UTIL Package \(Utility\)"](#)
- [Chapter 33, "SDO_WFS_LOCK Package \(WFS\)"](#)
- [Chapter 34, "SDO_WFS_PROCESS Package \(WFS Processing\)"](#)

To understand the examples in the reference chapters, you must understand the conceptual and data type information in [Chapter 2, "Spatial Data Types and Metadata"](#), especially [Section 2.2, "SDO_GEOMETRY Object Type"](#).

SQL Statements for Indexing Spatial Data

This chapter describes the SQL statements used when working with the spatial object data type. The statements are listed in [Table 18–1](#).

Table 18–1 *Spatial Index Creation and Usage Statements*

Statement	Description
ALTER INDEX	Alters specific parameters for a spatial index.
ALTER INDEX REBUILD	Rebuilds a spatial index or a specified partition of a partitioned index.
ALTER INDEX RENAME TO	Changes the name of a spatial index or a partition of a spatial index.
CREATE INDEX	Creates a spatial index on a column of type SDO_GEOMETRY.
DROP INDEX	Deletes a spatial index.

This chapter focuses on using these SQL statements with spatial indexes. For complete reference information about any statement, see *Oracle Database SQL Language Reference*.

Bold italic text is often used in the **Keywords and Parameters** sections in this chapter to identify a grouping of keywords, followed by specific keywords in the group. For example, *INDEX_PARAMS* identifies the start of a group of index-related keywords.

ALTER INDEX

Purpose

Alters specific parameters for a spatial index.

Syntax

```
ALTER INDEX [schema.]index PARAMETERS ('index_params [physical_storage_params]' )
    [{ NOPARALLEL | PARALLEL [ integer ] }];
```

Keywords and Parameters

Value	Description
<i>INDEX_PARAMS</i>	Changes the characteristics of the spatial index.
sdo_indx_dims	Specifies the number of dimensions to be indexed. For example, a value of 2 causes only the first two dimensions to be indexed. Must be less than or equal to the number of actual dimensions. For usage information related to three-dimensional geometries, see Section 1.11 . Data type is NUMBER. Default = 2.
sdo_rtr_pctfree	Specifies the minimum percentage of slots in each index tree node to be left empty when the index is created. Slots that are left empty can be filled later when new data is inserted into the table. The value can range from 0 to 50. The default value is best for most applications; however, a value of 0 is recommended if no updates will be performed to the geometry column. Data type is NUMBER. Default = 10.
<i>PHYSICAL_STORAGE_PARAMS</i>	Determines the storage parameters used for altering the spatial index data table. A spatial index data table is a standard Oracle table with a prescribed format. Not all physical storage parameters that are allowed in the STORAGE clause of a CREATE TABLE statement are supported. The following is a list of the supported subset.
tablespace	Specifies the tablespace in which the index data table is created. This parameter is the same as TABLESPACE in the STORAGE clause of a CREATE TABLE statement.
initial	Is the same as INITIAL in the STORAGE clause of a CREATE TABLE statement.
next	Is the same as NEXT in the STORAGE clause of a CREATE TABLE statement.
minextents	Is the same as MINEXTENTS in the STORAGE clause of a CREATE TABLE statement.
maxextents	Is the same as MAXEXTENTS in the STORAGE clause of a CREATE TABLE statement.
pctincrease	Is the same as PCTINCREASE in the STORAGE clause of a CREATE TABLE statement.

Value	Description
{ <i>NOPARALLEL</i> <i>PARALLEL</i> [<i>integer</i>] }	Controls whether serial (<i>NOPARALLEL</i>) execution or parallel (<i>PARALLEL</i>) execution is used for subsequent queries and DML operations that use the index. For parallel execution you can specify an integer value of degree of parallelism. See the Usage Notes for the CREATE INDEX statement for guidelines and restrictions that apply to the use of the <i>PARALLEL</i> keyword. Default = <i>NOPARALLEL</i> . (If <i>PARALLEL</i> is specified without an integer value, the Oracle database calculates the optimum degree of parallelism.)

Prerequisites

- You must have EXECUTE privileges on the index type and its implementation type.
- The spatial index to be altered is not marked in-progress.

Usage Notes

Use this statement to change the parameters of an existing index.

See the Usage Notes for the [CREATE INDEX](#) statement for usage information about many of the other available parameters.

Examples

The following example modifies the tablespace for partition IP2 of the spatial index named BGI.

```
ALTER INDEX bgi MODIFY PARTITION ip2
PARAMETERS ('tablespace=TBS_3');
```

Related Topics

- [ALTER INDEX REBUILD](#)
- [ALTER INDEX RENAME TO](#)
- [CREATE INDEX](#)
- ALTER TABLE (clauses for partition maintenance) in *Oracle Database SQL Language Reference*

ALTER INDEX REBUILD

Syntax

```
ALTER INDEX [schema.]index REBUILD
  [PARAMETERS ('rebuild_params [physical_storage_params]' ) ]
  [{ NOPARALLEL | PARALLEL [ integer ] }];
```

or

```
ALTER INDEX [schema.]index REBUILD ONLINE
  [PARAMETERS ('rebuild_params [physical_storage_params]' ) ]
  [{ NOPARALLEL | PARALLEL [ integer ] }];
```

or

```
ALTER INDEX [schema.]index REBUILD PARTITION partition
  [PARAMETERS ('rebuild_params [physical_storage_params]' )];
```

Purpose

Rebuilds a spatial index or a specified partition of a partitioned index.

Keywords and Parameters

Value	Description
<i>REBUILD_PARAMS</i>	Specifies in a command string the index parameters to use in rebuilding the spatial index.
index_status=cleanup	For an online rebuild operation (ALTER INDEX REBUILD ONLINE), performs cleanup operations on tables associated with the older version of the index.
layer_gtype	Checks to ensure that all geometries are of a specified geometry type. The value must be from the Geometry Type column of Table 2–1 in Section 2.2.1 (except that UNKNOWN_GEOMETRY is not allowed). In addition, specifying POINT allows for optimized processing of point data. Data type is VARCHAR2.
sdo_dml_batch_size	Specifies the number of index updates to be processed in each batch of updates after a commit operation. The default value is 1000. For example, if you insert 3500 rows into the spatial table and then perform a commit operation, the updates to the spatial index table are performed in four batches of insert operations (1000, 1000, 1000, and 500). See the Usage Notes for the CREATE INDEX statement for more information. Data type is NUMBER. Default = 1000.
sdo_indx_dims	Specifies the number of dimensions to be indexed. For example, a value of 2 causes only the first two dimensions to be indexed. Must be less than or equal to the number of actual dimensions. For usage information related to three-dimensional geometries, see Section 1.11 . Data type is NUMBER. Default = 2.

Value	Description
sdo_rtr_pctfree	Specifies the minimum percentage of slots in each index tree node to be left empty when the index is created. Slots that are left empty can be filled later when new data is inserted into the table. The value can range from 0 to 50. Data type is NUMBER. Default = 10.
PHYSICAL_STORAGE_PARAMS	Determines the storage parameters used for rebuilding the spatial index data table. A spatial index data table is a regular Oracle table with a prescribed format. Not all physical storage parameters that are allowed in the STORAGE clause of a CREATE TABLE statement are supported. The following is a list of the supported subset.
tablespace	Specifies the tablespace in which the index data table is created. Same as TABLESPACE in the STORAGE clause of a CREATE TABLE statement.
initial	Is the same as INITIAL in the STORAGE clause of a CREATE TABLE statement.
next	Is the same as NEXT in the STORAGE clause of a CREATE TABLE statement.
minextents	Is the same as MINEXTENTS in the STORAGE clause of a CREATE TABLE statement.
maxextents	Is the same as MAXEXTENTS in the STORAGE clause of a CREATE TABLE statement.
pctincrease	Is the same as PCTINCREASE in the STORAGE clause of a CREATE TABLE statement.
{ NOPARALLEL PARALLEL [<i>integer</i>] }	Controls whether serial (NOPARALLEL) execution or parallel (PARALLEL) execution is used for the rebuilding of the index and for subsequent queries and DML operations that use the index. For parallel execution you can specify an integer value of degree of parallelism. See the Usage Notes for the CREATE INDEX statement for guidelines and restrictions that apply to the use of the PARALLEL keyword. Default = NOPARALLEL. (If PARALLEL is specified without an integer value, the Oracle database calculates the optimum degree of parallelism.)

Prerequisites

- You must have EXECUTE privileges on the index type and its implementation type.
- The spatial index to be altered is not marked in-progress.

Usage Notes

An ALTER INDEX REBUILD 'rebuild_params' statement rebuilds the index using supplied parameters. Spatial index creation involves creating and inserting index data, for each row in the underlying table column being spatially indexed, into a table with a prescribed format. All rows in the underlying table are processed before the insertion of index data is committed, and this requires adequate rollback segment space.

The ONLINE keyword rebuilds the index without blocking the index; that is, queries can use the spatial index while it is being rebuilt. However, after all queries issued during the rebuild operation have completed, you must clean up the old index information (in the MDRT tables) by entering a SQL statement in the following form:

```
ALTER INDEX [schema.]index REBUILD ONLINE PARAMETERS ('index_status=cleanup');
```

The following limitations apply to the use of the ONLINE keyword:

- Only query operations are permitted while the index is being rebuilt. Insert, update, and delete operations that would affect the index are blocked while the index is being rebuilt; and an online rebuild is blocked while any insert, update, or delete operations that would affect the index are being performed.
- You cannot use the ONLINE keyword for a rebuild operation if the index was created using the 'sdo_non_leaf_tbl=TRUE' parameter.
- You cannot use the ONLINE keyword for a partitioned spatial index.

The ALTER INDEX REBUILD statement does not use any previous parameters from the index creation. All parameters should be specified for the index you want to rebuild.

For more information about using the `layer_gtype` keyword to constrain data in a layer to a geometry type, see [Section 5.1.1](#).

With a partitioned spatial index, you must use a separate ALTER INDEX REBUILD statement for each partition to be rebuilt.

If you want to use a *local* partitioned spatial index, follow the procedure in [Section 5.1.3.1](#).

See also the Usage Notes for the [CREATE INDEX](#) statement for usage information about many of the available parameters and about the use of the PARALLEL keyword.

Examples

The following example rebuilds OLDINDEX and specifies the tablespace in which to create the index data table.

```
ALTER INDEX oldindex REBUILD PARAMETERS('tablespace=TBS_3');
```

Related Topics

- [CREATE INDEX](#)
- [DROP INDEX](#)
- ALTER TABLE and ALTER INDEX (clauses for partition maintenance) in *Oracle Database SQL Language Reference*

ALTER INDEX RENAME TO

Syntax

```
ALTER INDEX [schema.]index RENAME TO <new_index_name>;
```

```
ALTER INDEX [schema.]index PARTITION partition RENAME TO <new_partition_name>;
```

Purpose

Changes the name of a spatial index or a partition of a spatial index.

Keywords and Parameters

Value	Description
new_index_name	Specifies the new name of the index.
new_partition_name	Specifies the new name of the partition.

Prerequisites

- You must have EXECUTE privileges on the index type and its implementation type.
- The spatial index to be altered is not marked in-progress.

Usage Notes

None.

Examples

The following example renames OLDINDEX to NEWINDEX.

```
ALTER INDEX oldindex RENAME TO newindex;
```

Related Topics

- [CREATE INDEX](#)
- [DROP INDEX](#)

CREATE INDEX

Syntax

```
CREATE INDEX [schema.]index ON [schema.]table (column)
  INDEXTYPE IS MDSYS.SPATIAL_INDEX
  [PARAMETERS ('index_params [physical_storage_params]' )]
  [{ NOPARALLEL | PARALLEL [ integer ] }];
```

Purpose

Creates a spatial index on a column of type SDO_GEOMETRY.

Keywords and Parameters

Value	Description
<i>INDEX_PARAMS</i>	Determines the characteristics of the spatial index.
layer_gtype	Checks to ensure that all geometries are of a specified geometry type. The value must be from the Geometry Type column of Table 2–1 in Section 2.2.1 (except that UNKNOWN_GEOMETRY is not allowed). In addition, specifying POINT allows for optimized processing of point data. Data type is VARCHAR2.
sdo_dml_batch_size	Specifies the number of index updates to be processed in each batch of updates after a commit operation. The default value is 1000. For example, if you insert 3500 rows into the spatial table and then perform a commit operation, the updates to the spatial index table are performed in four batches of insert operations (1000, 1000, 1000, and 500). See the Usage Notes for more information. Data type is NUMBER. Default = 1000.
sdo_indx_dims	Specifies the number of dimensions to be indexed. For example, a value of 2 causes only the first two dimensions to be indexed. Must be less than or equal to the number of actual dimensions. For usage information related to three-dimensional geometries, see Section 1.11 . Data type is NUMBER. Default = 2.
sdo_non_leaf_tbl	'sdo_non_leaf_tbl=TRUE' creates a separate index table (with a name in the form MDNT_...\$) for nonleaf nodes of the index, in addition to creating an index table (with a name in the form MDRT_...\$) for leaf nodes. 'sdo_non_leaf_tbl=FALSE' creates a single table (with a name in the form MDRT_...\$) for both leaf nodes and nonleaf nodes of the index. See the Usage Notes for more information. Data type is VARCHAR2. Default = FALSE
sdo_rtr_pctfree	Specifies the minimum percentage of slots in each index tree node to be left empty when the index is created. Slots that are left empty can be filled later when new data is inserted into the table. The value can range from 0 to 50. Data type is NUMBER. Default = 10.

Value	Description
<i>PHYSICAL_STORAGE_PARAMS</i>	Determines the storage parameters used for creating the spatial index data table. A spatial index data table is a regular Oracle table with a prescribed format. Not all physical storage parameters that are allowed in the STORAGE clause of a CREATE TABLE statement are supported. The following is a list of the supported subset.
tablespace	Specifies the tablespace in which the index data table is created. Same as TABLESPACE in the STORAGE clause of a CREATE TABLE statement.
initial	Is the same as INITIAL in the STORAGE clause of a CREATE TABLE statement.
next	Is the same as NEXT in the STORAGE clause of a CREATE TABLE statement.
minextents	Is the same as MINEXTENTS in the STORAGE clause of a CREATE TABLE statement.
maxextents	Is the same as MAXEXTENTS in the STORAGE clause of a CREATE TABLE statement.
pctincrease	Is the same as PCTINCREASE in the STORAGE clause of a CREATE TABLE statement.
work_tablespace	Specifies the tablespace for temporary tables used in creating the index. (Applies only to creating spatial R-tree indexes, and not to other types of indexes.) Specifying a work tablespace reduces fragmentation in the index tablespace, but it requires storage space of two times the size of the final index; however, after the index is created you can drop or reuse the work tablespace.
{ <i>NOPARALLEL</i> <i>PARALLEL</i> [<i>integer</i>] }	Controls whether serial (<i>NOPARALLEL</i>) execution or parallel (<i>PARALLEL</i>) execution is used for the creation of the index and for subsequent queries and DML operations that use the index. For parallel execution you can specify an integer value of degree of parallelism. See the Usage Notes for more information about parallel index creation. Default = <i>NOPARALLEL</i> . (If <i>PARALLEL</i> is specified without an integer value, the Oracle database calculates the optimum degree of parallelism.)

Prerequisites

- All current SQL CREATE INDEX prerequisites apply.
- You must have EXECUTE privilege on the index type and its implementation type.
- The USER_SDO_GEOM_METADATA view must contain an entry with the dimensions and coordinate boundary information for the table column to be spatially indexed.

Usage Notes

For information about spatial indexes, see [Section 1.7](#).

Before you create a spatial index, be sure that the rollback segment size and the SORT_AREA_SIZE parameter value are adequate, as described in [Section 5.1](#).

If an R-tree index is used on linear referencing system (LRS) data and if the LRS data has four dimensions (three plus the M dimension), the `sdo_indx_dims` parameter must be used and must specify 3 (the number of dimensions minus one), to avoid the default `sdo_indx_dims` value of 2, which would index only the X and Y dimensions. For example, if the dimensions are X, Y, Z, and M, specify `sdo_indx_dims=3` to

index the X, Y, and Z dimensions, but not the measure (M) dimension. (The LRS data model, including the measure dimension, is explained in [Section 7.2](#).)

A partitioned spatial index can be created on a partitioned table. See [Section 5.1.3](#) for more information about partitioned spatial indexes, including benefits and restrictions.

If you want to use a *local* partitioned spatial index, follow the procedure in [Section 5.1.3.1](#).

A spatial index cannot be created on an index-organized table.

You can specify the `PARALLEL` keyword to cause the index creation to be parallelized. For example:

```
CREATE INDEX cola_spatial_idx ON cola_markets(shape)
  INDEXTYPE IS MDSYS.SPATIAL_INDEX PARALLEL;
```

For information about using the `PARALLEL` keyword, see the description of the `parallel_clause` in the section on the `CREATE INDEX` statement in *Oracle Database SQL Language Reference*. In addition, the following notes apply to the use of the `PARALLEL` keyword for creating or rebuilding (using the [ALTER INDEX REBUILD](#) statement) spatial indexes:

- The performance cost and benefits from parallel execution for creating or rebuilding an index depend on system resources and load. If the CPUs or disk controllers are already heavily loaded, you should not specify the `PARALLEL` keyword.
- Specifying `PARALLEL` for creating or rebuilding an index on tables with simple geometries, such as point data, usually results in less performance improvement than on tables with complex geometries.

Other options available for regular indexes (such as `ASC` and `DESC`) are not applicable for spatial indexes.

Spatial index creation involves creating and inserting index data, for each row in the underlying table column being spatially indexed, into a table with a prescribed format. All rows in the underlying table are processed before the insertion of index data is committed, and this requires adequate rollback segment space.

If a tablespace name is provided in the parameters clause, the user (underlying table owner) must have appropriate privileges for that tablespace.

For more information about using the `layer_gtype` keyword to constrain data in a layer to a geometry type, see [Section 5.1.1](#).

The `sdo_dml_batch_size` parameter can improve application performance, because Spatial can preallocate system resources to perform multiple index updates more efficiently than successive single index updates; however, to gain the performance benefit, you must not perform commit operations after each insert operation or at intervals less than or equal to the `sdo_dml_batch_size` value. You should not specify a value greater than 10000 (ten thousand), because the cost of the additional memory and other resources required will probably outweigh any marginal performance increase resulting from such a value.

Specifying `'sdo_non_leaf_tbl=TRUE'` can help query performance with large data sets if the entire R-tree table may not fit in the `KEEP` buffer pool. In this case, you must also cause Oracle to buffer the `MDNT_...$` table in the `KEEP` buffer pool, for example, by using `ALTER TABLE` and specifying `STORAGE (BUFFER_POOL KEEP)`. For partitioned indexes, the same `sdo_non_leaf_tbl` value must be used for all partitions. Any physical storage parameters, except for tablespace, are applied only

to the MDRT_...\$ table. The MDNT_...\$ table uses only the `tablespace` parameter, if specified, and default values for all other physical storage parameters.

If you are creating a function-based spatial index, the number of parameters must not exceed 32. For information about using function-based spatial indexes, see [Section 9.2](#).

To determine if a [CREATE INDEX](#) statement for a spatial index has failed, check to see if the `DOMIDX_OPSTATUS` column in the `USER_INDEXES` view is set to `FAILED`. This is different from the case of regular indexes, where you check to see if the `STATUS` column in the `USER_INDEXES` view is set to `FAILED`.

If the [CREATE INDEX](#) statement fails because of an invalid geometry, the `ROWID` of the failed geometry is returned in an error message along with the reason for the failure.

If the [CREATE INDEX](#) statement fails for any reason, then the [DROP INDEX](#) statement must be used to clean up the partially built index and associated metadata. If [DROP INDEX](#) does not work, add the `FORCE` parameter and try again.

Examples

The following example creates a spatial R-tree index named `COLA_SPATIAL_IDX`.

```
CREATE INDEX cola_spatial_idx ON cola_markets(shape)
  INDEXTYPE IS MDSYS.SPATIAL_INDEX;
```

Related Topics

- [ALTER INDEX](#)
- [DROP INDEX](#)

DROP INDEX

Syntax

```
DROP INDEX [schema.]index [FORCE];
```

Purpose

Deletes a spatial index.

Keywords and Parameters

Value	Description
FORCE	Causes the spatial index to be deleted from the system tables even if the index is marked in-progress or some other error condition occurs.

Prerequisites

You must have EXECUTE privileges on the index type and its implementation type.

Usage Notes

Use [DROP INDEX](#) indexname FORCE to clean up after a failure in the [CREATE INDEX](#) statement.

Examples

The following example deletes a spatial index named OLDINDEX and forces the deletion to be performed even if the index is marked in-process or an error occurs.

```
DROP INDEX oldindex FORCE;
```

Related Topics

- [CREATE INDEX](#)

Spatial Operators

This chapter describes the operators that you can use when working with the spatial object data type. For an overview of spatial operators, including how they differ from spatial procedures and functions, see [Section 1.9](#). [Table 19–1](#) lists the main operators.

Table 19–1 *Main Spatial Operators*

Operator	Description
SDO_FILTER	Specifies which geometries may interact with a given geometry.
SDO_JOIN	Performs a spatial join based on one or more topological relationships.
SDO_NN	Determines the nearest neighbor geometries to a geometry.
SDO_NN_DISTANCE	Returns the distance of an object returned by the SDO_NN operator.
SDO_RELATE	Determines whether or not two geometries interact in a specified way. (See also Table 19–2 for convenient alternative operators for performing specific mask value operations.)
SDO_WITHIN_DISTANCE	Determines if two geometries are within a specified distance from one another.

[Table 19–2](#) lists operators, provided for convenience, that perform an [SDO_RELATE](#) operation of a specific mask type.

Table 19–2 *Convenience Operators for SDO_RELATE Operations*

Operator	Description
SDO_ANYINTERACT	Checks if any geometries in a table have the ANYINTERACT topological relationship with a specified geometry.
SDO_CONTAINS	Checks if any geometries in a table have the CONTAINS topological relationship with a specified geometry.
SDO_COVEREDBY	Checks if any geometries in a table have the COVEREDBY topological relationship with a specified geometry.
SDO_COVERS	Checks if any geometries in a table have the COVERS topological relationship with a specified geometry.
SDO_EQUAL	Checks if any geometries in a table have the EQUAL topological relationship with a specified geometry.
SDO_INSIDE	Checks if any geometries in a table have the INSIDE topological relationship with a specified geometry.

Table 19–2 (Cont.) Convenience Operators for SDO_RELATE Operations

Operator	Description
<code>SDO_ON</code>	Checks if any geometries in a table have the ON topological relationship with a specified geometry.
<code>SDO_OVERLAPBDYDISJOINT</code>	Checks if any geometries in a table have the OVERLAPBDYDISJOINT topological relationship with a specified geometry.
<code>SDO_OVERLAPBDYINTERSECT</code>	Checks if any geometries in a table have the OVERLAPBDYINTERSECT topological relationship with a specified geometry.
<code>SDO_OVERLAPS</code>	Checks if any geometries in a table overlap (that is, have the OVERLAPBDYDISJOINT or OVERLAPBDYINTERSECT topological relationship with) a specified geometry.
<code>SDO_TOUCH</code>	Checks if any geometries in a table have the TOUCH topological relationship with a specified geometry.

The rest of this chapter provides reference information on the operators, listed in alphabetical order.

For information about using operators with topologies, see *Oracle Spatial Topology and Network Data Models Developer's Guide*.

SDO_ANYINTERACT

Format

```
SDO_ANYINTERACT(geometry1, geometry2);
```

Description

Checks if any geometries in a table have the ANYINTERACT topological relationship with a specified geometry. Equivalent to specifying the [SDO_RELATE](#) operator with 'mask=ANYINTERACT'.

See the section on the [SDO_RELATE](#) operator in this chapter for information about the operations performed by this operator and for usage requirements.

Keywords and Parameters

Value	Description
geometry1	Specifies a geometry column in a table. The column must be spatially indexed. Data type is SDO_GEOMETRY.
geometry2	Specifies either a geometry from a table or a transient instance of a geometry. (Specified using a bind variable or SDO_GEOMETRY constructor.) Data type is SDO_GEOMETRY.

Returns

The expression `SDO_ANYINTERACT(geometry1,geometry2) = 'TRUE'` evaluates to TRUE for object pairs that have the ANYINTERACT topological relationship, and FALSE otherwise.

Usage Notes

See the Usage Notes for the [SDO_RELATE](#) operator in this chapter.

For an explanation of the topological relationships and the nine-intersection model used by Spatial, see [Section 1.8](#).

For information about 3D support with Spatial operators (which operators do and do not consider all three dimensions in their computations), see [Section 1.11](#).

Examples

The following example finds geometries that have the ANYINTERACT relationship with a query window (here, a rectangle with lower-left, upper-right coordinates 4,6, 8,8). (The example uses the definitions and data described in [Section 2.1](#) and illustrated in [Figure 2-1](#).)

```
SELECT c.mkt_id, c.name
FROM cola_markets c
WHERE SDO_ANYINTERACT(c.shape,
    SDO_GEOMETRY(2003, NULL, NULL,
        SDO_ELEM_INFO_ARRAY(1,1003,3),
        SDO_ORDINATE_ARRAY(4,6, 8,8))
    ) = 'TRUE';
```

```
MKT_ID NAME
-----
2 cola_b
1 cola_a
4 cola_d
```

SDO_CONTAINS

Format

```
SDO_CONTAINS(geometry1, geometry2);
```

Description

Checks if any geometries in a table have the CONTAINS topological relationship with a specified geometry. Equivalent to specifying the [SDO_RELATE](#) operator with 'mask=CONTAINS'.

See the section on the [SDO_RELATE](#) operator in this chapter for information about the operations performed by this operator and for usage requirements.

Keywords and Parameters

Value	Description
geometry1	Specifies a geometry column in a table. The column must be spatially indexed. Data type is SDO_GEOMETRY.
geometry2	Specifies either a geometry from a table or a transient instance of a geometry. (Specified using a bind variable or SDO_GEOMETRY constructor.) Data type is SDO_GEOMETRY.

Returns

The expression `SDO_CONTAINS(geometry1,geometry2) = 'TRUE'` evaluates to TRUE for object pairs that have the CONTAINS topological relationship, and FALSE otherwise.

Usage Notes

See the Usage Notes for the [SDO_RELATE](#) operator in this chapter.

For an explanation of the topological relationships and the nine-intersection model used by Spatial, see [Section 1.8](#).

For information about 3D support with Spatial operators (which operators do and do not consider all three dimensions in their computations), see [Section 1.11](#).

Examples

The following example finds geometries that have the CONTAINS relationship with a query window (here, a rectangle with lower-left, upper-right coordinates 2,2, 4,6). (The example uses the definitions and data described in [Section 2.1](#) and illustrated in [Figure 2-1](#).) In this example, only `cola_a` contains the query window geometry.

```
SELECT c.mkt_id, c.name
FROM cola_markets c
WHERE SDO_CONTAINS(c.shape,
    SDO_GEOMETRY(2003, NULL, NULL,
        SDO_ELEM_INFO_ARRAY(1,1003,3),
        SDO_ORDINATE_ARRAY(2,2, 4,6))
    ) = 'TRUE';
```

```
MKT_ID NAME
-----
1 cola_a
```

SDO_COVEREDBY

Format

```
SDO_COVEREDBY(geometry1, geometry2);
```

Description

Checks if any geometries in a table have the COVEREDBY topological relationship with a specified geometry. Equivalent to specifying the [SDO_RELATE](#) operator with 'mask=COVEREDBY'.

See the section on the [SDO_RELATE](#) operator in this chapter for information about the operations performed by this operator and for usage requirements.

Keywords and Parameters

Value	Description
geometry1	Specifies a geometry column in a table. The column must be spatially indexed. Data type is SDO_GEOMETRY.
geometry2	Specifies either a geometry from a table or a transient instance of a geometry. (Specified using a bind variable or SDO_GEOMETRY constructor.) Data type is SDO_GEOMETRY.

Returns

The expression `SDO_COVEREDBY(geometry1,geometry2) = 'TRUE'` evaluates to TRUE for object pairs that have the COVEREDBY topological relationship, and FALSE otherwise.

Usage Notes

See the Usage Notes for the [SDO_RELATE](#) operator in this chapter.

For an explanation of the topological relationships and the nine-intersection model used by Spatial, see [Section 1.8](#).

For information about 3D support with Spatial operators (which operators do and do not consider all three dimensions in their computations), see [Section 1.11](#).

Examples

The following example finds geometries that have the COVEREDBY relationship with a query window (here, a rectangle with lower-left, upper-right coordinates 1,1, 5,8). (The example uses the definitions and data described in [Section 2.1](#) and illustrated in [Figure 2-1](#).) In this example, only cola_a is covered by the query window geometry.

```
SELECT c.mkt_id, c.name
FROM cola_markets c
WHERE SDO_COVEREDBY(c.shape,
    SDO_GEOMETRY(2003, NULL, NULL,
        SDO_ELEM_INFO_ARRAY(1,1003,3),
        SDO_ORDINATE_ARRAY(1,1, 5,8))
) = 'TRUE';
```

```
MKT_ID NAME
-----
1 cola_a
```

SDO_COVERS

Format

```
SDO_COVERS(geometry1, geometry2);
```

Description

Checks if any geometries in a table have the COVERS topological relationship with a specified geometry. Equivalent to specifying the [SDO_RELATE](#) operator with 'mask=COVERS'.

See the section on the [SDO_RELATE](#) operator in this chapter for information about the operations performed by this operator and for usage requirements.

Keywords and Parameters

Value	Description
geometry1	Specifies a geometry column in a table. The column must be spatially indexed. Data type is SDO_GEOMETRY.
geometry2	Specifies either a geometry from a table or a transient instance of a geometry. (Specified using a bind variable or SDO_GEOMETRY constructor.) Data type is SDO_GEOMETRY.

Returns

The expression `SDO_COVERS(geometry1, geometry2) = 'TRUE'` evaluates to TRUE for object pairs that have the COVERS topological relationship, and FALSE otherwise.

Usage Notes

See the Usage Notes for the [SDO_RELATE](#) operator in this chapter.

For an explanation of the topological relationships and the nine-intersection model used by Spatial, see [Section 1.8](#).

For information about 3D support with Spatial operators (which operators do and do not consider all three dimensions in their computations), see [Section 1.11](#).

Examples

The following example finds geometries that have the COVERS relationship with a query window (here, a rectangle with lower-left, upper-right coordinates 1,1, 4,6). (The example uses the definitions and data described in [Section 2.1](#) and illustrated in [Figure 2-1](#).) In this example, only `cola_a` covers the query window geometry.

```
SELECT c.mkt_id, c.name
FROM cola_markets c
WHERE SDO_COVERS(c.shape,
                 SDO_GEOMETRY(2003, NULL, NULL,
                               SDO_ELEM_INFO_ARRAY(1,1003,3),
                               SDO_ORDINATE_ARRAY(1,1, 4,6))
                 ) = 'TRUE';
```

```
MKT_ID NAME
-----
```

1 cola_a

SDO_EQUAL

Format

```
SDO_EQUAL(geometry1, geometry2);
```

Description

Checks if any geometries in a table have the EQUAL topological relationship with a specified geometry. Equivalent to specifying the [SDO_RELATE](#) operator with 'mask=EQUAL'.

See the section on the [SDO_RELATE](#) operator in this chapter for information about the operations performed by this operator and for usage requirements.

Keywords and Parameters

Value	Description
geometry1	Specifies a geometry column in a table. The column must be spatially indexed. Data type is SDO_GEOMETRY.
geometry2	Specifies either a geometry from a table or a transient instance of a geometry. (Specified using a bind variable or SDO_GEOMETRY constructor.) Data type is SDO_GEOMETRY.

Returns

The expression `SDO_EQUAL(geometry1,geometry2) = 'TRUE'` evaluates to TRUE for object pairs that have the EQUAL topological relationship, and FALSE otherwise.

Usage Notes

See the Usage Notes for the [SDO_RELATE](#) operator in this chapter.

For an explanation of the topological relationships and the nine-intersection model used by Spatial, see [Section 1.8](#).

For information about 3D support with Spatial operators (which operators do and do not consider all three dimensions in their computations), see [Section 1.11](#).

Examples

The following example finds geometries that have the EQUAL relationship with a query window (here, a rectangle with lower-left, upper-right coordinates 1,1, 5,7). (The example uses the definitions and data described in [Section 2.1](#) and illustrated in [Figure 2-1](#).) In this example, `cola_a` (and only `cola_a`) has the same boundary and interior as the query window geometry.

```
SELECT c.mkt_id, c.name
FROM cola_markets c
WHERE SDO_EQUAL(c.shape,
    SDO_GEOMETRY(2003, NULL, NULL,
        SDO_ELEM_INFO_ARRAY(1,1003,3),
        SDO_ORDINATE_ARRAY(1,1, 5,7))
    ) = 'TRUE';
```

```
MKT_ID NAME
-----
1 cola_a
```

SDO_FILTER

Format

SDO_FILTER(geometry1, geometry2, param);

Description

Uses the spatial index to identify either the set of spatial objects that are likely to interact spatially with a given object (such as an area of interest), or pairs of spatial objects that are likely to interact spatially. Objects interact spatially if they are not disjoint.

This operator performs only a primary filter operation. The secondary filtering operation, performed by the [SDO_RELATE](#) operator, can be used to determine with certainty if objects interact spatially.

Keywords and Parameters

Value	Description
geometry1	Specifies a geometry column in a table. The column must be spatially indexed. Data type is SDO_GEOMETRY.
geometry2	Specifies either a geometry from a table or a transient instance of a geometry. (Specified using a bind variable or SDO_GEOMETRY constructor.) Data type is SDO_GEOMETRY.
param	Optionally specifies either or both of the <code>min_resolution</code> and <code>max_resolution</code> keywords. Data type is VARCHAR2. The <code>min_resolution</code> keyword includes only geometries for which at least one side of the geometry's MBR is equal to or greater than the specified value. For example, <code>min_resolution=10</code> includes only geometries for which the width or the height (or both) of the geometry's MBR is at least 10. (This keyword can be used to exclude geometries that are too small to be of interest.) The <code>max_resolution</code> keyword includes only geometries for which at least one side of the geometry's MBR is less than or equal to the specified value. For example, <code>max_resolution=10</code> includes only geometries for which the width or the height (or both) of the geometry's MBR is less than or equal to 10. (This keyword can be used to exclude geometries that are too large to be of interest.)

Returns

The expression `SDO_FILTER(geometry1,geometry2) = 'TRUE'` evaluates to TRUE for object pairs that are non-disjoint, and FALSE otherwise.

Usage Notes

The SDO_FILTER operator must always be used in a WHERE clause and the condition that includes the operator should be an expression of the form `SDO_FILTER(arg1, arg2) = 'TRUE'`.

`geometry2` can come from a table or be a transient SDO_GEOMETRY object, such as a bind variable or SDO_GEOMETRY constructor.

- If the `geometry2` column is not spatially indexed, the operator indexes the query window in memory and performance is very good.
- If two or more geometries from `geometry2` are passed to the operator, the `ORDERED` optimizer hint must be specified, and the table in `geometry2` must be specified first in the `FROM` clause.

If `geometry1` and `geometry2` are based on different coordinate systems, `geometry2` is temporarily transformed to the coordinate system of `geometry1` for the operation to be performed, as described in [Section 6.10.1](#).

RLS Restriction: If the `DBMS_RLS.ADD_POLICY` procedure has been used to add a fine-grained access control policy to a table or view, and if the specified policy function uses a spatial operator, the operator must be `SDO_FILTER`. No other spatial operators are supported in that context.

For information about 3D support with Spatial operators (which operators do and do not consider all three dimensions in their computations), see [Section 1.11](#).

Examples

The following example selects the geometries that are likely to interact with a query window (here, a rectangle with lower-left, upper-right coordinates 4,6, 8,8). (The example uses the definitions and data described in [Section 2.1](#) and illustrated in [Figure 2–1](#).)

```
SELECT c.mkt_id, c.name
FROM cola_markets c
WHERE SDO_FILTER(c.shape,
  SDO_GEOMETRY(2003, NULL, NULL,
    SDO_ELEM_INFO_ARRAY(1,1003,3),
    SDO_ORDINATE_ARRAY(4,6, 8,8))
) = 'TRUE';

MKT_ID NAME
-----
      2 cola_b
      1 cola_a
      4 cola_d
```

The following example is the same as the preceding example, except that it includes only geometries where at least one side of the geometry's MBR is equal to or greater than 4.1. In this case, only `cola_a` and `cola_b` are returned, because their MBRs have at least one side with a length greater than or equal to 4.1. The circle `cola_d` is excluded, because its MBR is a square whose sides have a length of 4.

```
SELECT c.mkt_id, c.name
FROM cola_markets c
WHERE SDO_FILTER(c.shape,
  SDO_GEOMETRY(2003, NULL, NULL,
    SDO_ELEM_INFO_ARRAY(1,1003,3),
    SDO_ORDINATE_ARRAY(4,6, 8,8)),
  'min_resolution=4.1'
) = 'TRUE';

MKT_ID NAME
-----
      2 cola_b
```

```
1 cola_a
```

The following example selects the GID values from the POLYGONS table where the GEOMETRY column objects are likely to interact spatially with the GEOMETRY column object in the QUERY_POLYS table that has a GID value of 1.

```
SELECT A.gid
   FROM Polygons A, query_polys B
  WHERE B.gid = 1
     AND SDO_FILTER(A.Geometry, B.Geometry) = 'TRUE';
```

The following example selects the GID values from the POLYGONS table where the GEOMETRY column object is likely to interact spatially with the geometry stored in the aGeom variable.

```
Select A.Gid
   FROM Polygons A
  WHERE SDO_FILTER(A.Geometry, :aGeom) = 'TRUE';
```

The following example selects the GID values from the POLYGONS table where the GEOMETRY column object is likely to interact spatially with the specified rectangle having the lower-left coordinates (x1,y1) and the upper-right coordinates (x2, y2).

```
Select A.Gid
   FROM Polygons A
  WHERE SDO_FILTER(A.Geometry, sdo_geometry(2003,NULL,NULL,
                                           sdo_elem_info_array(1,1003,3),
                                           sdo_ordinate_array(x1,y1,x2,y2))
        ) = 'TRUE';
```

The following example selects the GID values from the POLYGONS table where the GEOMETRY column object is likely to interact spatially with any GEOMETRY column object in the QUERY_POLYS table. In this example, the ORDERED optimizer hint is used and the QUERY_POLYS(geometry2) table is specified first in the FROM clause, because multiple geometries from geometry2 are involved (see the Usage Notes).

```
SELECT /*+ ORDERED */
   A.gid
   FROM query_polys B, polygons A
  WHERE SDO_FILTER(A.Geometry, B.Geometry) = 'TRUE';
```

Related Topics

- [SDO_RELATE](#)

SDO_INSIDE

Format

```
SDO_INSIDE(geometry1, geometry2);
```

Description

Checks if any geometries in a table have the **INSIDE** topological relationship with a specified geometry. Equivalent to specifying the [SDO_RELATE](#) operator with 'mask=INSIDE'.

See the section on the [SDO_RELATE](#) operator in this chapter for information about the operations performed by this operator and for usage requirements.

Keywords and Parameters

Value	Description
geometry1	Specifies a geometry column in a table. The column must be spatially indexed. Data type is SDO_GEOMETRY.
geometry2	Specifies either a geometry from a table or a transient instance of a geometry. (Specified using a bind variable or SDO_GEOMETRY constructor.) Data type is SDO_GEOMETRY.

Returns

The expression `SDO_INSIDE(geometry1,geometry2) = 'TRUE'` evaluates to **TRUE** for object pairs that have the **INSIDE** topological relationship, and **FALSE** otherwise.

Usage Notes

See the Usage Notes for the [SDO_RELATE](#) operator in this chapter.

For an explanation of the topological relationships and the nine-intersection model used by Spatial, see [Section 1.8](#).

For information about 3D support with Spatial operators (which operators do and do not consider all three dimensions in their computations), see [Section 1.11](#).

Examples

The following example finds geometries that have the **INSIDE** relationship with a query window (here, a rectangle with lower-left, upper-right coordinates 5,6, 12,12). (The example uses the definitions and data described in [Section 2.1](#) and illustrated in [Figure 2-1](#).) In this example, only `cola_d` (the circle) is inside the query window geometry.

```
SELECT c.mkt_id, c.name
FROM cola_markets c
WHERE SDO_INSIDE(c.shape,
                SDO_GEOMETRY(2003, NULL, NULL,
                SDO_ELEM_INFO_ARRAY(1,1003,3),
                SDO_ORDINATE_ARRAY(5,6, 12,12))
                ) = 'TRUE';
```

MKT_ID NAME

4 cola_d

SDO_JOIN

Format

```
SDO_JOIN(table_name1, column_name1, table_name2, column_name2, params,
         preserve_join_order, table1_partition, table2_partition) RETURN SDO_ROWIDSET;
```

Description

Performs a spatial join based on one or more topological relationships.

Keywords and Parameters

Value	Description
table_name1	Name of the first table to be used in the spatial join operation. The table must have a column of type SDO_GEOMETRY. Data type is VARCHAR2.
column_name1	Name of the spatial column of type SDO_GEOMETRY in table_name1. A spatial R-tree index must be defined on this column. Data type is VARCHAR2.
table_name2	Name of the second table to be used in the spatial join operation. (It can be the same as or different from table_name1. If table_name2 is the same as table_name1, see " Optimizing Self-Joins " in this section.) The table must have a column of type SDO_GEOMETRY. Data type is VARCHAR2.
column_name2	Name of the spatial column of type SDO_GEOMETRY in table_name2. A spatial R-tree index must be defined on this column. Data type is VARCHAR2.
params	Optional parameter string of keywords and values; available only if mask=ANYINTERACT. Determines the behavior of the operator. See Table 19-3 in the Usage Notes for information about the available keywords. Data type is VARCHAR2. Default is NULL.
preserve_join_order	Optional parameter to specify if the join order is guaranteed to be preserved during processing of the operator. If the value is 0 (the default), the order of the tables might be changed; if the value is 1, the order of the tables is not changed. Data type is NUMBER. Default is 0.
table1_partition	Name of the table partition in table_name1. Must be specified if the table has a partitioned spatial index; must be null if the table does not have a partitioned spatial index. (For information about using partitioned spatial indexes, see Section 5.1.3 .) Data type is VARCHAR2. Default is null.
table2_partition	Name of the table partition in table_name2. Must be specified if the table has a partitioned spatial index; must be null if the table does not have a partitioned spatial index. (For information about using partitioned spatial indexes, see Section 5.1.3 .) Data type is VARCHAR2. Default is null.

Returns

SDO_JOIN returns an object of SDO_ROWIDSET, which consists of a table of objects of SDO_ROWIDPAIR. Oracle Spatial defines the type SDO_ROWIDSET as:

```
CREATE TYPE sdo_rowidset as TABLE OF sdo_rowidpair;
```

Oracle Spatial defines the object type SDO_ROWIDPAIR as:

```
CREATE TYPE sdo_rowidpair AS OBJECT
  (rowid1 VARCHAR2(24),
   rowid2 VARCHAR2(24));
```

In the SDO_ROWIDPAIR definition, rowid1 refers to a rowid from table_name1, and rowid2 refers to a rowid from table_name2.

Usage Notes

SDO_JOIN is technically not an operator, but a table function. (For an explanation of table functions, see *Oracle Database PL/SQL Language Reference*.) However, it is presented in the chapter with Spatial operators because its usage is similar to that of the operators, and because it is not part of a package with other functions and procedures.

This table function is recommended when you need to perform full table joins.

The geometries in column_name1 and column_name2 must have the same SRID (coordinate system) value and the same number of dimensions.

For best performance, use the `/*+ ORDERED */` optimizer hint, and specify the SDO_JOIN table function first in the FROM clause.

If a table is version-enabled (using the Workspace Manager feature), you must specify the `<table_name>_LT` table created by Workspace Manager. For example, if the COLA_MARKETS table is version-enabled and you want to perform a spatial join operation on that table, specify COLA_MARKETS_LT (not COLA_MARKETS) with the SDO_JOIN table function. (However, for all other Spatial functions, procedures, and operators, do not use the `<table_name>_LT` name.)

Table 19–3 shows the keywords for the params parameter.

Table 19–3 params Keywords for the SDO_JOIN Operator

Keyword	Description
mask	<p>The topological relationship of interest. Valid values are 'mask=<value>' where <value> is one or more of the mask values valid for the SDO_RELATE operator (TOUCH, OVERLAPBDYDISJOINT, OVERLAPBDYINTERSECT, EQUAL, INSIDE, COVEREDBY, CONTAINS, COVERS, ANYINTERACT, ON), or FILTER, which checks if the MBRs (the filter-level approximations) intersect. Multiple masks are combined with the logical Boolean operator OR (for example, 'mask=inside+touch'); however, FILTER cannot be combined with any other mask.</p> <p>If this parameter is null or contains an empty string, mask=FILTER is assumed.</p>
distance	<p>Specifies a numeric distance value that is added to the tolerance value (explained in Section 1.5.5) before the relationship checks are performed. For example, if the tolerance is 10 meters and you specify 'distance=100 unit=meter', two objects are considered to have spatial interaction if they are within 110 meters of each other.</p> <p>If you specify distance but not unit, the unit of measurement associated with the data is assumed.</p>

Table 19–3 (Cont.) params Keywords for the SDO_JOIN Operator

Keyword	Description
unit	Specifies a unit of measurement to be associated with the distance value (for example, 'distance=100 unit=meter'). See Section 2.10 for more information about unit of measurement specification. If you specify unit, you must also specify distance. Data type is VARCHAR2. Default = unit of measurement associated with the data. For geodetic data, the default is meters.

Before you call SDO_JOIN, you must commit any previous DML statements in your session. Otherwise, the following error will be returned: `ORA-13236: internal error in R-tree processing: [SDO_Join in active txns not supported]`

For information about 3D support with Spatial operators (which operators do and do not consider all three dimensions in their computations), see [Section 1.11](#).

Optimizing Self-Joins

If you are performing a self-join (that is, if `table_name1` and `table_name2` specify the same table), you can improve the performance by optimizing the self-join.

If SDO_JOIN is called without a mask (for example, `ANYINTERACT`) or distance specification, it compares only the index structure of the two geometry columns being joined. This can quickly identify geometry pairs that are "likely" to interact. If SDO_JOIN is called with a mask or distance specification, after the index is used to identify geometry pairs that are likely to interact, geometry coordinates are also compared to see if the geometry pairs actually do interact. Coordinate comparison is the most expensive part of the SDO_JOIN operation.

In a self-join, where the same geometry column is compared to itself, each geometry pair is returned twice in the result set. For example:

- For the geometry pair with ID values (1,2), the pair (2,1) is also returned. The undesired effect in SDO_JOIN is that the coordinates of the same geometry pair are compared twice, instead of once.
- ID pairs that are equal are returned twice. For example, a table with 50,000 rows will return ID pair (1,1) twice, ID pair (2,2) twice, and so on. This is also an undesired effect.

When calling SDO_JOIN in a self-join scenario, you can eliminate the undesired effects by eliminating duplicate comparison of geometry pairs and all coordinate comparisons where the ID values of the pairs match. This optimization uses SDO_JOIN for the primary filter only, and calls the [SDO_GEOM.RELATE](#) function to compare geometry coordinates. The following statement accomplishes this optimization by adding "AND b.rowid < c.rowid" as a predicate to the WHERE clause.

```
SQL> set autotrace trace explain
SQL> SELECT /*+ ordered use_nl (a,b) use_nl (a,c) */ b.id, c.id
      FROM TABLE(sdo_join('GEOD_STATES', 'GEOM', 'GEOD_STATES', 'GEOM')) a,
      GEOD_STATES b,
      GEOD_STATES c
   WHERE a.rowid1 = b.rowid
      AND a.rowid2 = c.rowid
      AND b.rowid < c.rowid
```



```
AND SDO_GEOM.RELATE (b.geom, 'ANYINTERACT', c.geom, .05) = 'TRUE'
```

Execution Plan

Plan hash value: 1412731386

Id	Operation	Name	Rows	Bytes	Cost (%CPU)	Time
0	SELECT STATEMENT		1	1124	12787 (1)	00:02:34
1	NESTED LOOPS		1	1124	12787 (1)	00:02:34
2	NESTED LOOPS		4574	2514K	8206 (1)	00:01:39
3	COLLECTION ITERATOR PICKLER FETCH	SDO_JOIN				
* 4	TABLE ACCESS BY USER ROWID	GEOD_STATES	1	561	1 (0)	00:00:01
* 5	TABLE ACCESS BY USER ROWID	GEOD_STATES	1	561	1 (0)	00:00:01

Predicate Information (identified by operation id):

```

4 - access(CHARTOROWID(VALUE(KOKBF$)))
5 - access(CHARTOROWID(VALUE(KOKBF$)))
   filter("B".ROWID<"C".ROWID AND
          "SDO_GEOM".RELATE("B"."GEOM", 'ANYINTERACT', "C"."GEOM", .05)='TRUE')
```

SQL> set autotrace off

In the preceding example, It is very important that `AND b.rowid < c.rowid` be before the call to `SDO_GEOM.RELATE` in the `WHERE` clause. This will omit the undesired scenarios for the invocation of the `SDO_GEOM.RELATE` function. Also, note that the example uses the `ORDERED` and `USE_NL` hints, and that the execution plan does not contain `TABLE ACCESS FULL` or `HASH JOIN`.

Cross-Schema Invocation of SDO_JOIN

You can invoke the `SDO_JOIN` table function on an indexed table that is not in your schema, if you have been granted `SELECT` access to both the spatial table and to the index table for the spatial index that was created on the spatial table. To find the name of the index table for a spatial index, query the `SDO_INDEX_TABLE` column in the `USER_SDO_INDEX_METADATA` view. For example, the following statement returns the name of the index table for the `COLA_MARKETS_IDX` spatial index:

```
SELECT sdo_index_table FROM user_sdo_index_metadata
WHERE sdo_index_name = 'COLA_SPATIAL_IDX';
```

Assume that user A owns spatial table T1 (with index table `MDRT_F9AA$`), and that user B owns spatial table T2 and wants to join geometries from both T1 and T2. Assume also that the geometry column in both tables is named `GEOMETRY`.

User A or a suitably privileged user must connect as user A and execute the following statements:

```
GRANT select on T1 to B;
GRANT select on MDRT_F9AA$ to B;
```

User B can now connect and execute an `SDO_JOIN` query, such as the following:

```
SELECT COUNT(*) FROM
  (SELECT * FROM
    TABLE(SDO_JOIN('A.T1', 'GEOMETRY',
                   'B.T2', 'GEOMETRY',
                   'mask=anyinteract')) );
```

Examples

The following example joins the COLA_MARKETS table with itself to find, for each geometry, all other geometries that have any spatial interaction with it. (The example uses the definitions and data from [Section 2.1](#).) In this example, rowid1 and rowid2 correspond to the names of the attributes in the SDO_ROWIDPAIR type definition. Note that in the output, cola_d (the circle in [Figure 2-1](#)) interacts only with itself, and not with any of the other geometries.

```
SELECT /*+ ordered */ a.name, b.name
  FROM TABLE(SDO_JOIN('COLA_MARKETS', 'SHAPE',
                       'COLA_MARKETS', 'SHAPE',
                       'mask=ANYINTERACT')) c,
        cola_markets a,
        cola_markets b
 WHERE c.rowid1 = a.rowid AND c.rowid2 = b.rowid
 ORDER BY a.name;
```

NAME	NAME
cola_a	cola_c
cola_a	cola_b
cola_a	cola_a
cola_b	cola_c
cola_b	cola_b
cola_b	cola_a
cola_c	cola_c
cola_c	cola_b
cola_c	cola_a
cola_d	cola_d

10 rows selected.

Related Topics

- [SDO_RELATE](#)

SDO_NN

Format

SDO_NN(geometry1, geometry2, param [, number]);

Description

Uses the spatial index to identify the nearest neighbors for a geometry.

Keywords and Parameters

Value	Description
geometry1	Specifies a geometry column in a table. The column must be spatially indexed. Data type is SDO_GEOMETRY.
geometry2	Specifies either a geometry from a table or a transient instance of a geometry. The nearest neighbor or neighbors to <i>geometry2</i> will be returned from <i>geometry1</i> . (<i>geometry2</i> is specified using a bind variable or SDO_GEOMETRY constructor.) Data type is SDO_GEOMETRY.
param	Determines the behavior of the operator. The available keywords are listed in Table 19–4 . If you do not specify this parameter, the operator returns all rows in increasing distance order from <i>geometry2</i> . Data type is VARCHAR2.
number	If the SDO_NN_DISTANCE ancillary operator is included in the call to SDO_NN, specifies the same number used in the call to SDO_NN_DISTANCE . Data type is NUMBER.

[Table 19–4](#) lists the keywords for the *param* parameter.

Table 19–4 Keywords for the SDO_NN Param Parameter

Keyword	Description
distance	Specifies the number of distance units after which to stop searching for nearest neighbors. If you do not also specify the <i>unit</i> keyword, the default is the unit of measurement associated with the data. Data type is NUMBER. For example: 'distance=10 unit=mile'
sdo_batch_size	Specifies the number of rows to be evaluated at a time when the SDO_NN expression may need to be evaluated multiple times in order to return the desired number of results that satisfy the WHERE clause. Available only when an R-tree index is used. If you specify <i>sdo_batch_size=0</i> (or if you omit the <i>param</i> parameter completely), Spatial calculates a batch size suited to the result set size. See the Usage Notes and Examples for more information. Data type is NUMBER. For example: 'sdo_batch_size=10'

Table 19–4 (Cont.) Keywords for the SDO_NN Param Parameter

Keyword	Description
sdo_num_res	<p>If <code>sdo_batch_size</code> is not specified, specifies the number of results (nearest neighbors) to be returned. If <code>sdo_batch_size</code> is specified, this keyword is ignored; instead, use the ROWNUM pseudocolumn to limit the number of results. If neither <code>sdo_batch_size</code> nor <code>sdo_num_res</code> is specified, this is equivalent to specifying <code>sdo_batch_size=0</code>. See the Usage Notes and Examples for more information.</p> <p>Data type is NUMBER.</p> <p>For example: 'sdo_num_res=5'</p>
unit	<p>If the <code>distance</code> keyword or the SDO_NN_DISTANCE ancillary operator is included in the call to SDO_NN, specifies the unit of measurement: a quoted string with <code>unit=</code> and an SDO_UNIT value from the MDSYS.SDO_DIST_UNITS table. See Section 2.10 for more information about unit of measurement specification.</p> <p>Data type is VARCHAR2. Default = unit of measurement associated with the data. For geodetic data, the default is meters.</p> <p>For example: 'unit=KM'</p>

Returns

This operator returns the `sdo_num_res` number of objects from `geometry1` that are nearest to `geometry2` in the query. In determining how near two geometry objects are, the shortest possible distance between any two points on the surface of each object is used.

Usage Notes

The operator is disabled if the table does not have a spatial index or if the number of dimensions for the query window does not match the number of dimensions specified when the index was created.

The operator must always be used in a WHERE clause, and the condition that includes the operator should be an expression of the form `SDO_NN(arg1, arg2, '<some_parameter>') = 'TRUE'`.

The operator can be used in two ways:

- If all geometries in the layer are candidates, use the `sdo_num_res` keyword to specify the number of geometries returned.

The `sdo_num_res` keyword is especially useful when you are concerned only with proximity (for example, the three closest banks, regardless of bank name).

- If any geometries in the table might be nearer than the geometries specified in the WHERE clause, use the `sdo_batch_size` keyword and use the WHERE clause (including the ROWNUM pseudocolumn) to limit the number of geometries returned.

The `sdo_batch_size` keyword is especially useful when you need to consider one or more columns from the *same* table as the nearest neighbor search column in the WHERE clause (for example, the three closest banks whose name contains *MegaBank*).

As an example of the `sdo_batch_size` keyword, assume that a RESTAURANTS table contains different types of restaurants, and you want to find the two nearest Italian restaurants to your hotel but only if they are within two miles. The query might look like the following:

```
SELECT r.name FROM restaurants r WHERE
```

```
SDO_NN(r.geometry, :my_hotel,
'sdo_batch_size=10 distance=2 unit=mile') = 'TRUE'
AND r.cuisine = 'Italian' AND ROWNUM <=2;
```

In this example, the `ROWNUM <=2` clause is necessary to limit the number of results returned to no more than 2 where `CUISINE` is `Italian`. However, if the `sdo_batch_size` keyword is not specified in this example, and if `sdo_num_res=2` is specified instead of `ROWNUM <=2`, only the two nearest restaurants within two miles are considered, regardless of their `CUISINE` value; and if the `CUISINE` value of these two rows is not `Italian`, the query may return no rows.

The `sdo_batch_size` value can affect the performance of nearest neighbor queries. A good general guideline is to specify the number of candidate rows likely to satisfy the `WHERE` clause. Using the preceding example of a query for Italian restaurants, if approximately 20 percent of the restaurants nearest to the hotel are Italian and if you want 2 restaurants, an `sdo_batch_size` value of 10 will probably result in the best performance. On the other hand, if only approximately 5 percent of the restaurants nearest to the hotel are Italian and if you want 2 restaurants, an `sdo_batch_size` value of 40 would be better.

You can specify `sdo_batch_size=0`, which causes Spatial to calculate a batch size that is suitable for the result set size. However, the calculated batch size may not be optimal, and the calculation incurs some processing overhead; if you can determine a good `sdo_batch_size` value for a query, the performance will probably be better than if you specify `sdo_batch_size=0`.

If the `sdo_batch_size` keyword is specified, any `sdo_num_res` value is ignored. Do not specify both keywords.

Specify the `number` parameter only if you are using the [SDO_NN_DISTANCE](#) ancillary operator in the call to `SDO_NN`. See the information about the [SDO_NN_DISTANCE](#) operator in this chapter.

If two or more objects from `geometry1` are an equal distance from `geometry2`, any of the objects can be returned on any call to the function. For example, if `item_a`, `item_b`, and `item_c` are nearest to and equally distant from `geometry2`, and if `sdo_num_res=2`, two of those three objects are returned, but they can be any two of the three.

If the `SDO_NN` operator uses a partitioned spatial index (see [Section 5.1.3](#)), the requested number of geometries is returned for *each* partition that contains candidate rows based on the query criteria. For example, if you request the 5 nearest restaurants to a point and the spatial index has 4 partitions, the operator returns up to 20 (5*4) geometries. In this case, you must use the `ROWNUM` pseudocolumn (here, `WHERE ROWNUM <=5`) to return the 5 nearest restaurants.

If `geometry1` and `geometry2` are based on different coordinate systems, `geometry2` is temporarily transformed to the coordinate system of `geometry1` for the operation to be performed, as described in [Section 6.10.1](#).

`SDO_NN` is not supported for spatial joins.

In some situations the `SDO_NN` operator will not use the spatial index unless an optimizer hint forces the index to be used. This can occur when a query involves a join; and if the optimizer hint is not used in such situations, an internal error occurs. To prevent such errors, you should always specify an optimizer hint to use the spatial index with the `SDO_NN` operator, regardless of how simple or complex the query is. For example, the following excerpt from a query specifies to use the `COLA_SPATIAL_IDX` index that is defined on the `COLA_MARKETS` table:

```
SELECT /*+ INDEX(c cola_spatial_idx) */
```

```
c.mkt_id, c.name, ... FROM cola_markets c, ...;
```

However, if the column predicate in the WHERE clause specifies any nonspatial column in the table for `geometry1` that has an associated index, be sure that this index is not used by specifying the `NO_INDEX` hint for that index. For example, if there was an index named `COLA_NAME_IDX` defined on the `NAME` column, you would need to specify the hints in the preceding example as follows:

```
SELECT /*+ INDEX(c cola_spatial_idx) NO_INDEX(c cola_name_idx) */
       c.mkt_id, c.name, ... FROM cola_markets c, ...;
```

(Note, however, that there is no index named `COLA_NAME_IDX` in the example in [Section 2.1](#).)

If you join two or more tables with the `SDO_NN` operator and the `sdo_num_res` keyword, specify the `LEADING` hint for the outer table, `USE_NL` hint to have a nested loops join, and the `INDEX` hint for the inner table (the table with the spatial index). For example:

```
SELECT /*+ LEADING(b) USE_NL(b a) INDEX(a cola_spatial_idx) */ a.gid
       FROM cola_qry b, cola_markets a
       WHERE SDO_NN(a.shape, b.shape, 'sdo_num_res=1')='TRUE';
```

However, if you join two or more tables with the `SDO_NN` operator, the `sdo_batch_size` keyword, and the `ROWNUM` clause, the best way to implement the logic is to use a PL/SQL block. For example:

```
BEGIN
  FOR item IN ( SELECT b.shape FROM cola_qry b)
  LOOP
    SELECT /*+ INDEX(a cola_spatial_idx) */ a.gid INTO local_gid
    FROM cola_markets a
    WHERE SDO_NN(a.shape, item.shape, 'sdo_batch_size=10')='TRUE'
          and a.name like 'cola%' and ROWNUM <2;
  END LOOP;
END;
```

For detailed information about using optimizer hints, see *Oracle Database Performance Tuning Guide*.

For information about 3D support with Spatial operators (which operators do and do not consider all three dimensions in their computations), see [Section 1.11](#).

Examples

The following example finds the two objects from the `SHAPE` column in the `COLA_MARKETS` table that are nearest to a specified point (10,7). (The example uses the definitions and data described in [Section 2.1](#) and illustrated in [Figure 2-1](#).)

```
SELECT /*+ INDEX(c cola_spatial_idx) */
       c.mkt_id, c.name FROM cola_markets c WHERE SDO_NN(c.shape,
       sdo_geometry(2001, NULL, sdo_point_type(10,7,NULL), NULL,
       NULL), 'sdo_num_res=2') = 'TRUE';
```

```

MKT_ID NAME
-----
         2 cola_b
         4 cola_d
```

The following example uses the `sdo_batch_size` keyword to find the two objects (`ROWNUM <=2`), with a `NAME` value less than 'cola_d', from the `SHAPE` column in

the COLA_MARKETS table that are nearest to a specified point (10,7). The value of 3 for `sdo_batch_size` represents a best guess at the number of nearest geometries that need to be evaluated before the WHERE clause condition is satisfied. (The example uses the definitions and data from [Section 2.1](#).)

```
SELECT /*+ INDEX(c cola_spatial_idx) */ c.mkt_id, c.name
FROM cola_markets c
WHERE SDO_NN(c.shape, sdo_geometry(2001, NULL,
    sdo_point_type(10,7,NULL), NULL, NULL),
    'sdo_batch_size=3') = 'TRUE'
AND c.name < 'cola_d' AND ROWNUM <= 2;

MKT_ID NAME
-----
      2 cola_b
      3 cola_c
```

See also the more complex SDO_NN examples in [Section C.3](#).

Related Topics

- [SDO_NN_DISTANCE](#)

SDO_NN_DISTANCE

Format

SDO_NN_DISTANCE(number);

Description

Returns the distance of an object returned by the [SDO_NN](#) operator. Valid only within a call to the [SDO_NN](#) operator.

Keywords and Parameters

Value	Description
number	Specifies a number that must be the same as the last parameter passed to the SDO_NN operator. Data type is NUMBER.

Returns

This operator returns the distance of an object returned by the [SDO_NN](#) operator. In determining how near two geometry objects are, the shortest possible distance between any two points on the surface of each object is used.

Usage Notes

SDO_NN_DISTANCE is an ancillary operator to the [SDO_NN](#) operator. It returns the distance between the specified geometry and a nearest neighbor object. This distance is passed as ancillary data to the [SDO_NN](#) operator. (For an explanation of how operators can use ancillary data, see the section on ancillary data in the chapter on domain indexes in *Oracle Database Data Cartridge Developer's Guide*.)

You can choose any arbitrary number for the `number` parameter. The only requirement is that it must match the last parameter in the call to the [SDO_NN](#) operator.

Use a bind variable to store and operate on the distance value.

Examples

The following example finds the two objects from the SHAPE column in the COLA_MARKETS table that are nearest to a specified point (10,7), and it finds the distance between each object and the point. (The example uses the definitions and data described in [Section 2.1](#) and illustrated in [Figure 2-1](#).)

```
SELECT /*+ INDEX(c cola_spatial_idx) */
       c.mkt_id, c.name, SDO_NN_DISTANCE(1) dist
FROM   cola_markets c
WHERE  SDO_NN(c.shape, sdo_geometry(2001, NULL,
                                     sdo_point_type(10,7,NULL), NULL, NULL),
            'sdo_num_res=2', 1) = 'TRUE' ORDER BY dist;
```

MKT_ID	NAME	DIST
4	cola_d	.828427125
2	cola_b	2.23606798

Note the following about this example:

- 1 is used as the `number` parameter for `SDO_NN_DISTANCE`, and 1 is also specified as the last parameter to `SDO_NN` (after `'sdo_num_res=2'`).
- The column alias `dist` holds the distance between the object and the point. (For geodetic data, the distance unit is meters; for non-geodetic data, the distance unit is the unit associated with the data.)

The following example uses the `sdo_batch_size` keyword in selecting the two closest Italian restaurants to your hotel from a `YELLOW_PAGES` table that contains different types of businesses:

```
SELECT * FROM
  (SELECT /*+ FIRST_ROWS */ y.name FROM YELLOW_PAGES y
   WHERE SDO_NN(y.geometry, :my_hotel, 'sdo_batch_size=100', 1) = 'TRUE'
   AND y.business = 'Italian Restaurant'
   ORDER BY SDO_NN_DISTANCE(1))
 WHERE ROWNUM <=10;
```

In the preceding query, the `FIRST_ROWS` hint enables the optimizer to improve performance by pushing the `ORDER BY` operation into the spatial index. `:my_hotel` can be either a bind variable or a literal value.

The `FIRST_ROWS` hint is also available to a local partitioned spatial index. In the preceding example, if the `YELLOW_PAGES` table is partitioned by name, the query will be executed as follows:

1. For each partition, the `ORDER BY` operation is processed using the spatial index until 10 rows are found.
2. After all partitions are completed, all rows found in the preceding step are sorted, and the top 10 rows are returned.

Related Topics

- [SDO_NN](#)

SDO_ON

Format

```
SDO_ON(geometry1, geometry2);
```

Description

Checks if any geometries in a table have the ON topological relationship with a specified geometry. Equivalent to specifying the [SDO_RELATE](#) operator with 'mask=ON'.

See the section on the [SDO_RELATE](#) operator in this chapter for information about the operations performed by this operator and for usage requirements.

Keywords and Parameters

Value	Description
geometry1	Specifies a geometry column in a table. The column must be spatially indexed. Data type is SDO_GEOMETRY.
geometry2	Specifies either a geometry from a table or a transient instance of a geometry. (Specified using a bind variable or SDO_GEOMETRY constructor.) Data type is SDO_GEOMETRY.

Returns

The expression `SDO_ON(geometry1,geometry2) = 'TRUE'` evaluates to TRUE for object pairs that have the ON topological relationship, and FALSE otherwise.

Usage Notes

See the Usage Notes for the [SDO_RELATE](#) operator in this chapter.

For an explanation of the topological relationships and the nine-intersection model used by Spatial, see [Section 1.8](#).

For information about 3D support with Spatial operators (which operators do and do not consider all three dimensions in their computations), see [Section 1.11](#).

Examples

The following example finds geometries that have the ON relationship with a query window (here, a rectangle with lower-left, upper-right coordinates 4,6, 8,8). (The example uses the definitions and data described in [Section 2.1](#) and illustrated in [Figure 2-1](#).) This example returns no rows because there are no line string geometries in the SHAPE column.

```
SELECT c.mkt_id, c.name
FROM cola_markets c
WHERE SDO_ON(c.shape,
             SDO_GEOMETRY(2003, NULL, NULL,
                           SDO_ELEM_INFO_ARRAY(1,1003,3),
                           SDO_ORDINATE_ARRAY(4,6, 8,8))
             ) = 'TRUE';
```

no rows selected

SDO_OVERLAPBDYDISJOINT

Format

```
SDO_OVERLAPBDYDISJOINT(geometry1, geometry2);
```

Description

Checks if any geometries in a table have the OVERLAPBDYDISJOINT topological relationship with a specified geometry. Equivalent to specifying the [SDO_RELATE](#) operator with 'mask=OVERLAPBDYDISJOINT'.

See the section on the [SDO_RELATE](#) operator in this chapter for information about the operations performed by this operator and for usage requirements.

Keywords and Parameters

Value	Description
geometry1	Specifies a geometry column in a table. The column must be spatially indexed. Data type is SDO_GEOMETRY.
geometry2	Specifies either a geometry from a table or a transient instance of a geometry. (Specified using a bind variable or SDO_GEOMETRY constructor.) Data type is SDO_GEOMETRY.

Returns

The expression `SDO_OVERLAPBDYDISJOINT(geometry1,geometry2) = 'TRUE'` evaluates to TRUE for object pairs that have the OVERLAPBDYDISJOINT topological relationship, and FALSE otherwise.

Usage Notes

See the Usage Notes for the [SDO_RELATE](#) operator in this chapter.

For an explanation of the topological relationships and the nine-intersection model used by Spatial, see [Section 1.8](#).

For information about 3D support with Spatial operators (which operators do and do not consider all three dimensions in their computations), see [Section 1.11](#).

Examples

The following example finds geometries that have the OVERLAPBDYDISJOINT relationship with a line string geometry (here, a horizontal line from 0,6 to 2,6). (The example uses the definitions and data described in [Section 2.1](#) and illustrated in [Figure 2-1](#).) In this example, only cola_a has the OVERLAPBDYDISJOINT relationship with the line string geometry.

```
SELECT c.mkt_id, c.name
FROM cola_markets c
WHERE SDO_OVERLAPBDYDISJOINT(c.shape,
    SDO_GEOMETRY(2002, NULL, NULL,
        SDO_ELEM_INFO_ARRAY(1,2,1),
        SDO_ORDINATE_ARRAY(0,6, 2,6))
    ) = 'TRUE';
```

MKT_ID NAME

1 cola_a

SDO_OVERLAPBDYINTERSECT

Format

```
SDO_OVERLAPBDYINTERSECT(geometry1, geometry2);
```

Description

Checks if any geometries in a table have the OVERLAPBDYINTERSECT topological relationship with a specified geometry. Equivalent to specifying the [SDO_RELATE](#) operator with 'mask=OVERLAPBDYINTERSECT'.

See the section on the [SDO_RELATE](#) operator in this chapter for information about the operations performed by this operator and for usage requirements.

Keywords and Parameters

Value	Description
geometry1	Specifies a geometry column in a table. The column must be spatially indexed. Data type is SDO_GEOMETRY.
geometry2	Specifies either a geometry from a table or a transient instance of a geometry. (Specified using a bind variable or SDO_GEOMETRY constructor.) Data type is SDO_GEOMETRY.

Returns

The expression `SDO_OVERLAPBDYINTERSECT(geometry1, geometry2) = 'TRUE'` evaluates to TRUE for object pairs that have the OVERLAPBDYINTERSECT topological relationship, and FALSE otherwise.

Usage Notes

See the Usage Notes for the [SDO_RELATE](#) operator in this chapter.

For an explanation of the topological relationships and the nine-intersection model used by Spatial, see [Section 1.8](#).

For information about 3D support with Spatial operators (which operators do and do not consider all three dimensions in their computations), see [Section 1.11](#).

Examples

The following example finds geometries that have the OVERLAPBDYINTERSECT relationship with a query window (here, a rectangle with lower-left, upper-right coordinates 4,6, 8,8). (The example uses the definitions and data described in [Section 2.1](#) and illustrated in [Figure 2-1](#).) In this example, `cola_a`, `cola_b`, and `cola_d` have the OVERLAPBDYINTERSECT relationship with the query window geometry.

```
SELECT c.mkt_id, c.name
FROM cola_markets c
WHERE SDO_OVERLAPBDYINTERSECT(c.shape,
    SDO_GEOMETRY(2003, NULL, NULL,
        SDO_ELEM_INFO_ARRAY(1,1003,3),
        SDO_ORDINATE_ARRAY(4,6, 8,8))
```

```
) = 'TRUE';
```

```
MKT_ID NAME
```

```
-----  
2 cola_b  
1 cola_a  
4 cola_d
```

SDO_OVERLAPS

Format

```
SDO_OVERLAPS(geometry1, geometry2);
```

Description

Checks if any geometries in a table overlap (that is, have the OVERLAPBDYDISJOINT or OVERLAPBDYINTERSECT topological relationship with) a specified geometry.

Equivalent to specifying the [SDO_RELATE](#) operator with
'mask=OVERLAPBDYDISJOINT+OVERLAPBDYINTERSECT'.

See the section on the [SDO_RELATE](#) operator in this chapter for information about the operations performed by this operator and for usage requirements.

For information about 3D support with Spatial operators (which operators do and do not consider all three dimensions in their computations), see [Section 1.11](#).

Keywords and Parameters

Value	Description
geometry1	Specifies a geometry column in a table. The column must be spatially indexed. Data type is SDO_GEOMETRY.
geometry2	Specifies either a geometry from a table or a transient instance of a geometry. (Specified using a bind variable or SDO_GEOMETRY constructor.) Data type is SDO_GEOMETRY.

Returns

The expression `SDO_OVERLAPS(geometry1,geometry2) = 'TRUE'` evaluates to TRUE for object pairs that have the OVERLAPBDYDISJOINT or OVERLAPBDYINTERSECT topological relationship, and FALSE otherwise.

Usage Notes

See the Usage Notes for the [SDO_RELATE](#) operator in this chapter.

For an explanation of the topological relationships and the nine-intersection model used by Spatial, see [Section 1.8](#).

Examples

The following example finds geometries that overlap a query window (here, a rectangle with lower-left, upper-right coordinates 4,6, 8,8). (The example uses the definitions and data described in [Section 2.1](#) and illustrated in [Figure 2-1](#).) In this example, three of the geometries in the SHAPE column overlap the query window geometry.

```
SELECT c.mkt_id, c.name
FROM cola_markets c
WHERE SDO_OVERLAPS(c.shape,
    SDO_GEOMETRY(2003, NULL, NULL,
        SDO_ELEM_INFO_ARRAY(1,1003,3),
        SDO_ORDINATE_ARRAY(4,6, 8,8))
```

```
) = 'TRUE';
```

```
MKT_ID NAME
```

```
-----  
2 cola_b  
1 cola_a  
4 cola_d
```

SDO_RELATE

Format

```
SDO_RELATE(geometry1, geometry2, param);
```

Description

Uses the spatial index to identify either the spatial objects that have a particular spatial interaction with a given object such as an area of interest, or pairs of spatial objects that have a particular spatial interaction.

This operator performs both primary and secondary filter operations.

Keywords and Parameters

Value	Description
geometry1	Specifies a geometry column in a table. The column must be spatially indexed. Data type is SDO_GEOMETRY.
geometry2	Specifies either a geometry from a table or a transient instance of a geometry. (Specified using a bind variable or SDO_GEOMETRY constructor.) Data type is SDO_GEOMETRY.
param	<p>Specifies the <code>mask</code> keyword, and optionally either or both of the <code>min_resolution</code> and <code>max_resolution</code> keywords. The data type for this parameter is VARCHAR2.</p> <p>The <code>mask</code> keyword specifies the topological relationship of interest. This is a required parameter. Valid <code>mask</code> keyword values are one or more of the following in the nine-intersection pattern: TOUCH, OVERLAPBDYDISJOINT, OVERLAPBDYINTERSECT, EQUAL, INSIDE, COVEREDBY, CONTAINS, COVERS, ANYINTERACT, ON. Multiple masks are combined with the logical Boolean operator OR, for example, 'mask=inside+touch'; however, see the Usage Notes for an alternative syntax using UNION ALL that may result in better performance. See Section 1.8 for an explanation of the nine-intersection relationship pattern.</p> <p>The <code>min_resolution</code> keyword includes only geometries for which at least one side of the geometry's MBR is equal to or greater than the specified value. For example, <code>min_resolution=10</code> includes only geometries for which the width or the height (or both) of the geometry's MBR is at least 10. (This keyword can be used to exclude geometries that are too small to be of interest.)</p> <p>The <code>max_resolution</code> keyword includes only geometries for which at least one side of the geometry's MBR is less than or equal to the specified value. For example, <code>max_resolution=10</code> includes only geometries for which the width or the height (or both) of the geometry's MBR is less than or equal to 10. (This keyword can be used to exclude geometries that are too large to be of interest.)</p> <p>For backward compatibility, any additional keywords for the <code>param</code> parameter that were supported before release 10.1 will still work; however, the use of those keywords is discouraged and is not supported for new uses of the operator.</p>

Returns

The expression `SDO_RELATE(geometry1,geometry2, 'mask = <some_mask_val>') = 'TRUE'` evaluates to TRUE for object pairs that have the topological relationship specified by `<some_mask_val>`, and FALSE otherwise.

Usage Notes

The operator is disabled if the table does not have a spatial index or if the number of dimensions for the query window does not match the number of dimensions specified when the index was created.

The operator must always be used in a WHERE clause, and the condition that includes the operator should be an expression of the form `SDO_RELATE(arg1, arg2, 'mask = <some_mask_val>') = 'TRUE'`.

`geometry2` can come from a table or be a transient `SDO_GEOMETRY` object, such as a bind variable or `SDO_GEOMETRY` constructor.

- If the `geometry2` column is not spatially indexed, the operator indexes the query window in memory and performance is very good.
- If two or more geometries from `geometry2` are passed to the operator, the ORDERED optimizer hint must be specified, and the table in `geometry2` must be specified first in the FROM clause.

If `geometry1` and `geometry2` are based on different coordinate systems, `geometry2` is temporarily transformed to the coordinate system of `geometry1` for the operation to be performed, as described in [Section 6.10.1](#).

Unlike with the `SDO_GEOM.RELATE` function, DISJOINT and DETERMINE masks are not allowed in the relationship mask with the `SDO_RELATE` operator. This is because `SDO_RELATE` uses the spatial index to find candidates that may interact, and the information to satisfy DISJOINT or DETERMINE is not present in the index.

Although multiple masks can be combined using the logical Boolean operator OR, for example, `'mask=touch+coveredby'`, better performance may result if the spatial query specifies each mask individually and uses the UNION ALL syntax to combine the results. This is due to internal optimizations that Spatial can apply under certain conditions when masks are specified singly rather than grouped within the same `SDO_RELATE` operator call. (There are two exceptions, `inside+coveredby` and `contains+covers`, where the combination performs better than the UNION ALL alternative.) For example, consider the following query using the logical Boolean operator OR to group multiple masks:

```
SELECT a.gid
  FROM polygons a, query_polys B
 WHERE B.gid = 1
 AND SDO_RELATE(A.Geometry, B.Geometry,
                'mask=touch+coveredby') = 'TRUE';
```

The preceding query may result in better performance if it is expressed as follows, using UNION ALL to combine results of multiple `SDO_RELATE` operator calls, each with a single mask:

```
SELECT a.gid
  FROM polygons a, query_polys B
 WHERE B.gid = 1
 AND SDO_RELATE(A.Geometry, B.Geometry,
                'mask=touch') = 'TRUE'

UNION ALL
SELECT a.gid
```

```

FROM polygons a, query_polys B
WHERE B.gid = 1
AND SDO_RELATE(A.Geometry, B.Geometry,
               'mask=coveredby') = 'TRUE';

```

The following considerations apply to relationships between lines and a multipoint geometry (points in a point cluster). Assume the example of a line and a multipoint geometry (for example, SDO_GTYPE = 2005) consisting of three points.

- If none of the points has any interaction with the line, the relationship between the line and the point cluster is DISJOINT.
- If one of the points is on the interior of the line and the other two points are disjoint, the relationship between the line and the point cluster is OVERLAPBDYDISJOINT.
- If one of the points is on the boundary of the line (that is, if it is on the start point or end point of the line) and the other two points are disjoint, the relationship between the line and the point cluster is TOUCH.
- If one of the points is on the boundary of the line (that is, if it is on the start point or end point of the line), another point is on the interior of the line, and the third point is disjoint, the relationship between the line and the point cluster is OVERLAPBDYDISJOINT (not OVERLAPBDYINTERSECT).

For information about 3D support with Spatial operators (which operators do and do not consider all three dimensions in their computations), see [Section 1.11](#).

Examples

The following examples are similar to those for the [SDO_FILTER](#) operator; however, they identify a specific type of interaction (using the `mask` keyword), and they determine with certainty (not mere likelihood) if the spatial interaction occurs.

The following example selects the geometries that have any interaction with a query window (here, a rectangle with lower-left, upper-right coordinates 4,6, 8,8). (The example uses the definitions and data described in [Section 2.1](#) and illustrated in [Figure 2-1](#).)

```

SELECT c.mkt_id, c.name
FROM cola_markets c
WHERE SDO_RELATE(c.shape,
                SDO_GEOMETRY(2003, NULL, NULL,
                SDO_ELEM_INFO_ARRAY(1,1003,3),
                SDO_ORDINATE_ARRAY(4,6, 8,8)),
                'mask=anyinteract') = 'TRUE';

```

MKT_ID	NAME
2	cola_b
1	cola_a
4	cola_d

The following example is the same as the preceding example, except that it includes only geometries where at least one side of the geometry's MBR is equal to or greater than 4.1. In this case, only `cola_a` and `cola_b` are returned, because their MBRs have at least one side with a length greater than or equal to 4.1. The circle `cola_d` is excluded, because its MBR is a square whose sides have a length of 4.

```

SELECT c.mkt_id, c.name
FROM cola_markets c

```

```

WHERE SDO_RELATE(c.shape,
  SDO_GEOMETRY(2003, NULL, NULL,
    SDO_ELEM_INFO_ARRAY(1,1003,3),
    SDO_ORDINATE_ARRAY(4,6, 8,8)),
'mask=anyinteract min_resolution=4.1') = 'TRUE';

```

```

MKT_ID NAME
-----
      2 cola_b
      1 cola_a

```

The following example selects the GID values from the POLYGONS table where the GEOMETRY column objects have any spatial interaction with the GEOMETRY column object in the QUERY_POLYS table that has a GID value of 1.

```

SELECT A.gid
  FROM Polygons A, query_polys B
 WHERE B.gid = 1
 AND SDO_RELATE(A.Geometry, B.Geometry,
  'mask=ANYINTERACT') = 'TRUE';

```

The following example selects the GID values from the POLYGONS table where a GEOMETRY column object has any spatial interaction with the geometry stored in the aGeom variable.

```

SELECT A.Gid
  FROM Polygons A
 WHERE SDO_RELATE(A.Geometry, :aGeom, 'mask=ANYINTERACT') = 'TRUE';

```

The following example selects the GID values from the POLYGONS table where a GEOMETRY column object has any spatial interaction with the specified rectangle having the lower-left coordinates (x1,y1) and the upper-right coordinates (x2, y2).

```

SELECT A.Gid
  FROM Polygons A
 WHERE SDO_RELATE(A.Geometry, sdo_geometry(2003,NULL,NULL,
    sdo_elem_info_array(1,1003,3),
    sdo_ordinate_array(x1,y1,x2,y2)),
'mask=ANYINTERACT') = 'TRUE';

```

The following example selects the GID values from the POLYGONS table where the GEOMETRY column object has any spatial interaction with any GEOMETRY column object in the QUERY_POLYS table. In this example, the ORDERED optimizer hint is used and QUERY_POLYS (geometry2) table is specified first in the FROM clause, because multiple geometries from geometry2 are involved (see the Usage Notes).

```

SELECT /*+ ORDERED */
  A.gid
  FROM query_polys B, polygons A
 WHERE SDO_RELATE(A.Geometry, B.Geometry, 'mask=ANYINTERACT') = 'TRUE';

```

Related Topics

- [SDO_FILTER](#)
- [SDO_JOIN](#)
- [SDO_WITHIN_DISTANCE](#)
- [SDO_GEOM.RELATE](#) function

SDO_TOUCH

Format

```
SDO_TOUCH(geometry1, geometry2);
```

Description

Checks if any geometries in a table have the TOUCH topological relationship with a specified geometry. Equivalent to specifying the [SDO_RELATE](#) operator with 'mask=TOUCH'.

See the section on the [SDO_RELATE](#) operator in this chapter for information about the operations performed by this operator and for usage requirements.

Keywords and Parameters

Value	Description
geometry1	Specifies a geometry column in a table. The column must be spatially indexed. Data type is SDO_GEOMETRY.
geometry2	Specifies either a geometry from a table or a transient instance of a geometry. (Specified using a bind variable or SDO_GEOMETRY constructor.) Data type is SDO_GEOMETRY.

Returns

The expression `SDO_TOUCH(geometry1,geometry2) = 'TRUE'` evaluates to TRUE for object pairs that have the TOUCH topological relationship, and FALSE otherwise.

Usage Notes

See the Usage Notes for the [SDO_RELATE](#) operator in this chapter.

For an explanation of the topological relationships and the nine-intersection model used by Spatial, see [Section 1.8](#).

For information about 3D support with Spatial operators (which operators do and do not consider all three dimensions in their computations), see [Section 1.11](#).

Examples

The following example finds geometries that have the TOUCH relationship with a query window (here, a rectangle with lower-left, upper-right coordinates 1,1, 5,7). (The example uses the definitions and data in [Section 2.1](#) and illustrated in [Figure 2-1](#).) In this example, only `cola_b` has the TOUCH relationship with the query window geometry.

```
SELECT c.mkt_id, c.name
   FROM cola_markets c
  WHERE SDO_TOUCH(c.shape,
                 SDO_GEOMETRY(2003, NULL, NULL,
                               SDO_ELEM_INFO_ARRAY(1,1003,3),
                               SDO_ORDINATE_ARRAY(1,1, 5,7))
                 ) = 'TRUE';
   FROM cola_markets c
```

MKT_ID NAME

2 cola_b

SDO_WITHIN_DISTANCE

Format

```
SDO_WITHIN_DISTANCE(geometry1, aGeom, params);
```

Description

Uses the spatial index to identify the set of spatial objects that are within some specified distance of a given object, such as an area of interest or point of interest.

Keywords and Parameters

Value	Description
geometry1	Specifies a geometry column in a table. The column has the set of geometry objects that will be operated on to determine if they are within the specified distance of the given object (aGeom). The column must be spatially indexed. Data type is SDO_GEOMETRY.
aGeom	Specifies the object to be checked for distance against the geometry objects in geometry1. Specify either a geometry from a table (using a bind variable) or a transient instance of a geometry (using the SDO_GEOMETRY constructor). Data type is SDO_GEOMETRY.
params	A quoted string containing one or more keywords (with values) that determine the behavior of the operator. The remaining items (distance, max_resolution, min_resolution, querytype, and unit) are potential keywords for the params parameter. Data type is VARCHAR2.
distance	Specifies the distance value. If a coordinate system is associated with the geometry, the distance unit is assumed to be the unit associated with the coordinate system. This is a required keyword. Data type is NUMBER.
max_resolution	Includes only geometries for which at least one side of the geometry's MBR is less than or equal to the specified value. For example, max_resolution=10 includes only geometries for which the width or the height (or both) of the geometry's MBR is less than or equal to 10. (This keyword can be used to exclude geometries that are too large to be of interest.)
min_resolution	Includes only geometries for which at least one side of the geometry's MBR is equal to or greater than the specified value. For example, min_resolution=10 includes only geometries for which the width or the height (or both) of the geometry's MBR is at least 10. (This keyword can be used to exclude geometries that are too small to be of interest.)
querytype	Set 'querytype=FILTER' to perform only a primary filter operation. If querytype is not specified, both primary and secondary filter operations are performed (default). Data type is VARCHAR2.
unit	Specifies the unit of measurement: a quoted string with unit= and an SDO_UNIT value from the MDSYS.SDO_DIST_UNITS table (for example, 'unit=KM'). See Section 2.10 for more information about unit of measurement specification. Data type is NUMBER. Default = unit of measurement associated with the data. For geodetic data, the default is meters.

Returns

The expression `SDO_WITHIN_DISTANCE(arg1, arg2, arg3) = 'TRUE'` evaluates to `TRUE` for object pairs that are within the specified distance, and `FALSE` otherwise.

Usage Notes

The distance between two extended objects (nonpoint objects such as lines and polygons) is defined as the minimum distance between these two objects. The distance between two adjacent polygons is zero.

The operator is disabled if the table does not have a spatial index or if the number of dimensions for the query window does not match the number of dimensions specified when the index was created.

The operator must always be used in a `WHERE` clause and the condition that includes the operator should be an expression of the form:

```
SDO_WITHIN_DISTANCE(arg1, arg2, 'distance = <some_dist_val>') = 'TRUE'
```

The geometry column must have a spatial index built on it. If the data is geodetic, the spatial index must be an R-tree index.

`SDO_WITHIN_DISTANCE` is not supported for spatial joins. See [Section 5.2.1.3](#) for a discussion on how to perform a spatial join within-distance operation.

For information about 3D support with Spatial operators (which operators do and do not consider all three dimensions in their computations), see [Section 1.11](#).

Examples

The following example selects the geometries that are within a distance of 10 from a query window (here, a rectangle with lower-left, upper-right coordinates 4,6, 8,8). (The example uses the definitions and data described in [Section 2.1](#) and illustrated in [Figure 2–1](#). In this case, all geometries shown in that figure are returned.)

```
SELECT c.name FROM cola_markets c WHERE SDO_WITHIN_DISTANCE(c.shape,
  SDO_GEOMETRY(2003, NULL, NULL, SDO_ELEM_INFO_ARRAY(1,1003,3),
    SDO_ORDINATE_ARRAY(4,6, 8,8)),
  'distance=10') = 'TRUE';
```

```
NAME
-----
cola_b
cola_a
cola_c
cola_d
```

The following example is the same as the preceding example, except that it includes only geometries where at least one side of the geometry's MBR is equal to or greater than 4.1. In this case, only `cola_a` and `cola_b` are returned, because their MBRs have at least one side with a length greater than or equal to 4.1. The trapezoid `cola_c` is excluded, because its MBR has sides with lengths of 3 and 2; and the circle `cola_d` is excluded, because its MBR is a square whose sides have a length of 4.

```
SELECT c.name FROM cola_markets c WHERE SDO_WITHIN_DISTANCE(c.shape,
  SDO_GEOMETRY(2003, NULL, NULL, SDO_ELEM_INFO_ARRAY(1,1003,3),
    SDO_ORDINATE_ARRAY(4,6, 8,8)),
  'distance=10 min_resolution=4.1') = 'TRUE';
```

```
NAME
-----
```

```
cola_b  
cola_a
```

The following example selects the GID values from the POLYGONS table where the GEOMETRY column object is within 10 distance units of the geometry stored in the aGeom variable.

```
SELECT A.GID  
FROM POLYGONS A  
WHERE  
SDO_WITHIN_DISTANCE(A.Geometry, :aGeom, 'distance = 10') = 'TRUE';
```

The following example selects the GID values from the POLYGONS table where the GEOMETRY column object is within 10 distance units of the specified rectangle having the lower-left coordinates (x1,y1) and the upper-right coordinates (x2, y2).

```
SELECT A.GID  
FROM POLYGONS A  
WHERE  
SDO_WITHIN_DISTANCE(A.Geometry, sdo_geometry(2003,NULL,NULL,  
sdo_elem_info_array(1,1003,3),  
sdo_ordinate_array(x1,y1,x2,y2)),  
'distance = 10') = 'TRUE';
```

The following example selects the GID values from the POLYGONS table where the GID value in the QUERY_POINTS table is 1 and a POLYGONS.GEOMETRY object is within 10 distance units of the QUERY_POINTS.GEOMETRY object.

```
SELECT A.GID  
FROM POLYGONS A, Query_Points B  
WHERE B.GID = 1 AND  
SDO_WITHIN_DISTANCE(A.Geometry, B.Geometry, 'distance = 10') = 'TRUE';
```

See also the more complex SDO_WITHIN_DISTANCE examples in [Section C.2](#).

Related Topics

- [SDO_FILTER](#)
- [SDO_RELATE](#)

Spatial Aggregate Functions

This chapter contains reference and usage information for the spatial aggregate functions, which are listed in [Table 20-1](#).

Table 20-1 *Spatial Aggregate Functions*

Method	Description
SDO_AGGR_CENTROID	Returns a geometry object that is the centroid ("center of gravity") of the specified geometry objects.
SDO_AGGR_CONCAT_LINES	Returns a geometry that concatenates the specified line or multiline geometries.
SDO_AGGR_CONVEXHULL	Returns a geometry object that is the convex hull of the specified geometry objects.
SDO_AGGR_LRS_CONCAT	Returns an LRS geometry object that concatenates specified LRS geometry objects.
SDO_AGGR_MBR	Returns the minimum bounding rectangle of the specified geometries.
SDO_AGGR_SET_UNION	Takes a VARRAY of SDO_GEOMETRY objects as input, and returns the aggregate union of all geometry objects in the array.
SDO_AGGR_UNION	Returns a geometry object that is the topological union (<i>OR</i> operation) of the specified geometry objects.

See the usage information about spatial aggregate functions in [Section 1.10](#).

Most of these aggregate functions accept a parameter of type SDOAGGRTYPE, which is described in [Section 1.10.1](#).

Note: Spatial aggregate functions are supported for two-dimensional geometries only, except for [SDO_AGGR_MBR](#), which is supported for both two-dimensional and three-dimensional geometries.

SDO_AGGR_CENTROID

Format

```
SDO_AGGR_CENTROID(  
    AggregateGeometry SDOAGGRTYPE  
    ) RETURN SDO_GEOMETRY;
```

Description

Returns a geometry object that is the centroid ("center of gravity") of the specified geometry objects.

Parameters

AggregateGeometry

An object of type SDOAGGRTYPE (see [Section 1.10.1](#)) that specifies the geometry column and dimensional array.

Usage Notes

The behavior of the function depends on whether the geometry objects are all polygons, all points, or a mixture of polygons and points:

- If the geometry objects are all polygons, the centroid of all the objects is returned.
- If the geometry objects are all points, the centroid of all the objects is returned.
- If the geometry objects are a mixture of polygons and points (specifically, if they include at least one polygon and at least one point), any points are ignored, and the centroid of all the polygons is returned.

The result is weighted by the area of each polygon in the geometry objects. If the geometry objects are a mixture of polygons and points, the points are not used in the calculation of the centroid. If the geometry objects are all points, the points have equal weight.

See also the information about the [SDO_GEOM.SDO_CENTROID](#) function in [Chapter 24](#).

Examples

The following example returns the centroid of the geometry objects in the COLA_MARKETS table. (The example uses the definitions and data from [Section 2.1](#).)

```
SELECT SDO_AGGR_CENTROID(SDOAGGRTYPE(shape, 0.005))  
    FROM cola_markets;  
  
SDO_AGGR_CENTROID(SDOAGGRTYPE(SHAPE,0.005))(SDO_GTYPE, SDO_SRID, SDO_POINT  
-----  
SDO_GEOMETRY(2001, NULL, SDO_POINT_TYPE(5.21295938, 5.00744233, NULL), NULL, NUL  
L)
```

SDO_AGGR_CONCAT_LINES

Format

```
SDO_AGGR_CONCAT_LINES(
    geom SDO_GEOMETRY
) RETURN SDO_GEOMETRY;
```

Description

Returns a geometry that concatenates the specified line or multiline geometries.

Parameters

geom
Geometry objects.

Usage Notes

Each input geometry must be a two-dimensional line or multiline geometry (that is, the SDO_GTYPE value must be 2002 or 2006). This function is not supported for LRS geometries. To perform an aggregate concatenation of LRS geometric segments, use the [SDO_AGGR_LRS_CONCAT](#) spatial aggregate function.

The input geometries must be line strings whose vertices are connected by straight line segments. Circular arcs and compound line strings are not supported.

If any input geometry is a multiline geometry, the elements of the geometry must be disjoint. If they are not disjoint, this function may return incorrect results.

The topological relationship between the geometries in each pair of geometries to be concatenated must be DISJOINT or TOUCH; and if the relationship is TOUCH, the geometries must intersect only at two end points.

You can use the [SDO_UTIL.CONCAT_LINES](#) function (described in [Chapter 32](#)) to concatenate two line or multiline geometries.

An exception is raised if any input geometries are not line or multiline geometries, or if not all input geometries are based on the same coordinate system.

Examples

The following example inserts two line geometries in the COLA_MARKETS table, and then returns the aggregate concatenation of these geometries. (The example uses the data definitions from [Section 2.1](#).)

```
-- First, insert two line geometries.
INSERT INTO cola_markets VALUES(1001, 'line_1', SDO_GEOMETRY(2002, NULL, NULL,
    SDO_ELEM_INFO_ARRAY(1,2,1), SDO_ORDINATE_ARRAY(1,1, 5,1)));
INSERT INTO cola_markets VALUES(1002, 'line_2', SDO_GEOMETRY(2002, NULL, NULL,
    SDO_ELEM_INFO_ARRAY(1,2,1), SDO_ORDINATE_ARRAY(5,1, 8,1)));
-- Perform aggregate concatenation of all line geometries in layer.
SELECT SDO_AGGR_CONCAT_LINES(c.shape) FROM cola_markets c
    WHERE c.mkt_id > 1000;

SDO_AGGR_CONCAT_LINES(C.SHAPE)(SDO_GTYPE, SDO_SRID, SDO_POINT(X, Y, Z), SDO_ELEM
-----
SDO_GEOMETRY(2002, NULL, NULL, SDO_ELEM_INFO_ARRAY(1, 2, 1), SDO_ORDINATE_ARRAY(
```

1, 1, 5, 1, 8, 1))

SDO_AGGR_CONVEXHULL

Format

```
SDO_AGGR_CONVEXHULL(
  AggregateGeometry SDOAGGRTYPE
) RETURN SDO_GEOMETRY;
```

Description

Returns a geometry object that is the convex hull of the specified geometry objects.

Parameters

AggregateGeometry

An object of type SDOAGGRTYPE (see [Section 1.10.1](#)) that specifies the geometry column and dimensional array.

Usage Notes

See also the information about the [SDO_GEOM.SDO_CONVEXHULL](#) function in [Chapter 24](#).

Examples

The following example returns the convex hull of the geometry objects in the COLA_MARKETS table. (The example uses the definitions and data from [Section 2.1](#).)

```
SELECT SDO_AGGR_CONVEXHULL(SDOAGGRTYPE(shape, 0.005))
FROM cola_markets;
```

```
SDO_AGGR_CONVEXHULL(SDOAGGRTYPE(SHAPE,0.005))(SDO_GTYPE, SDO_SRID, SDO_POI
-----
SDO_GEOMETRY(2003, NULL, NULL, SDO_ELEM_INFO_ARRAY(1, 1003, 1), SDO_ORDINATE_ARR
AY(8, 1, 10, 7, 10, 11, 8, 11, 6, 11, 1, 7, 1, 1, 8, 1))
```

SDO_AGGR_LRS_CONCAT

Format

```
SDO_AGGR_LRS_CONCAT(
    AggregateGeometry SDOAGGRTYPE
) RETURN SDO_GEOMETRY;
```

Description

Returns an LRS geometry that concatenates specified LRS geometries.

Parameters

AggregateGeometry

An object of type SDOAGGRTYPE (see [Section 1.10.1](#)) that specifies the geometry column and dimensional array.

Usage Notes

This function performs an aggregate concatenation of any number of LRS geometries. If you want to control the order in which the geometries are concatenated, you must use a subquery with the NO_MERGE optimizer hint and the ORDER BY clause. (See the examples.)

The direction of the resulting segment is the same as the direction of the first geometry in the concatenation.

A 3D format of this function (SDO_AGGR_LRS_CONCAT_3D) is available. For information about 3D formats of LRS functions, see [Section 7.4](#).)

For information about the Spatial linear referencing system, see [Chapter 7](#).

Examples

The following example adds an LRS geometry to the LRS_ROUTES table, and then performs two queries that concatenate the LRS geometries in the table. The first query does not control the order of concatenation, and the second query controls the order of concatenation. Notice the difference in direction of the two segments: the segment resulting from the second query has decreasing measure values because the first segment in the concatenation (Route0) has decreasing measure values. (This example uses the definitions from the example in [Section 7.7](#).)

```
-- Add a segment with route_id less than 1 (here, zero).
INSERT INTO lrs_routes VALUES(
    0,
    'Route0',
    SDO_GEOMETRY(
        3302, -- Line string; 3 dimensions (X,Y,M); 3rd is measure dimension.
        NULL,
        NULL,
        SDO_ELEM_INFO_ARRAY(1,2,1), -- One line string, straight segments
        SDO_ORDINATE_ARRAY(
            5,14,5, -- Starting point - 5 is measure from start.
            10,14,0) -- Ending point - 0 measure (decreasing measure)
        )
);
```

1 row created.

-- Concatenate all routes (no ordering specified).

```
SELECT SDO_AGGR_LRS_CONCAT(SDOAGGRTYPE(route_geometry, 0.005))
      FROM lrs_routes;
```

```
SDO_AGGR_LRS_CONCAT(SDOAGGRTYPE(ROUTE_GEOMETRY,0.005))(SDO_GTYPE, SDO_SRID
```

```
-----
SDO_GEOMETRY(3302, NULL, NULL, SDO_ELEM_INFO_ARRAY(1, 2, 1), SDO_ORDINATE_ARRAY(
2, 2, 0, 2, 4, 2, 8, 4, 8, 12, 4, 12, 12, 10, 18, 8, 10, 22, 5, 14, 27, 10, 14,
32))
```

-- Aggregate concatenation using subquery for ordering.

```
SELECT
SDO_AGGR_LRS_CONCAT(SDOAGGRTYPE(route_geometry, 0.005))
FROM (
      SELECT /*+ NO_MERGE */ route_geometry
      FROM lrs_routes
      ORDER BY route_id);
```

```
SDO_AGGR_LRS_CONCAT(SDOAGGRTYPE(ROUTE_GEOMETRY,0.005))(SDO_GTYPE, SDO_SRID
```

```
-----
SDO_GEOMETRY(3302, NULL, NULL, SDO_ELEM_INFO_ARRAY(1, 2, 1), SDO_ORDINATE_ARRAY(
2, 2, 32, 2, 4, 30, 8, 4, 24, 12, 4, 20, 12, 10, 14, 8, 10, 10, 5, 14, 5, 10, 14
, 0))
```

SDO_AGGR_MBR

Format

```
SDO_AGGR_MBR(  
    geom SDO_GEOMETRY  
    ) RETURN SDO_GEOMETRY;
```

Description

Returns the minimum bounding rectangle (MBR) of the specified geometries, that is, a single rectangle that minimally encloses the geometries.

Parameters

geom
Geometry objects.

Usage Notes

This function does not return an MBR geometry if a proper MBR cannot be constructed. Specifically:

- If the input geometries are all null, the function returns a null geometry.
- If all data in the input geometries is on a single point, the function returns the point.
- If all data in the input geometries consists of points on a straight line, the function returns a two-point line.

The [SDO_TUNE.EXTENT_OF](#) function, documented in [Chapter 31](#), also returns the MBR of geometries. The [SDO_TUNE.EXTENT_OF](#) function has better performance than the [SDO_AGGR_MBR](#) function if the data is non-geodetic and if a spatial index is defined on the geometry column; however, the [SDO_TUNE.EXTENT_OF](#) function is limited to two-dimensional geometries, whereas the [SDO_AGGR_MBR](#) function is not. In addition, the [SDO_TUNE.EXTENT_OF](#) function computes the extent for all geometries in a table; by contrast, the [SDO_AGGR_MBR](#) function can operate on subsets of rows.

Examples

The following example returns the minimum bounding rectangle of the geometry objects in the COLA_MARKETS table. (The example uses the definitions and data from [Section 2.1](#).)

```
SELECT SDO_AGGR_MBR(shape) FROM cola_markets;  
  
SDO_AGGR_MBR(C.SHAPE) (SDO_GTYPE, SDO_SRID, SDO_POINT(X, Y, Z), SDO_ELEM_INFO, SD  
-----  
SDO_GEOMETRY(2003, NULL, NULL, SDO_ELEM_INFO_ARRAY(1, 1003, 3), SDO_ORDINATE_ARR  
AY(1, 1, 10, 11))
```

SDO_AGGR_SET_UNION

Format

```
SDO_AGGR_SET_UNION(
    geometry SDO_GEOMETRY_ARRAY
    tol NUMBER
) RETURN SDO_GEOMETRY;
```

Description

Takes a VARRAY of SDO_GEOMETRY objects as input, and returns the aggregate union of all geometry objects in the array.

Parameters

geometry

An array of geometry objects of object type SDO_GEOMETRY_ARRAY, which is defined as VARRAY OF SDO_GEOMETRY.

tol

Tolerance value (see [Section 1.5.5](#)).

Usage Notes

SDO_AGGR_SET_UNION provides faster performance than SDO_AGG_UNION but less flexibility, and SDO_AGGR_SET_UNION should be considered when performance is especially important and when it satisfies your functional needs.

SDO_AGG_UNION is a SQL aggregate function, and therefore it very flexible and can be used with complex SQL GROUP BY clauses. However, SDO_AGGR_SET_UNION can be much faster than SDO_AGG_UNION. SDO_AGGR_SET_UNION is useful when the geometries to be grouped can easily be gathered into a collection (that is, a VARRAY of SDO_GEOMETRY objects).

SDO_AGGR_SET_UNION:

- *Cannot* aggregate a set of *overlapping* polygons. For overlapping polygons, use SDO_AGG_UNION.
- *Can* effectively aggregate a set of *non-overlapping* polygons, including polygons that touch.
- Can aggregate sets of lines and points, even if they overlap.

Examples

The following example creates a generic routine to build a geometry set to pass to SDO_AGGR_SET_UNION. It takes as input a table name, column name, and optional predicate to apply, and returns an SDO_GEOMETRY_ARRAY ready to use with SDO_AGGR_SET_UNION. (The example uses the definitions and data from [Section 2.1](#).)

```
CREATE OR REPLACE FUNCTION get_geom_set (table_name VARCHAR2,
                                         column_name VARCHAR2,
                                         predicate VARCHAR2 := NULL)
RETURN SDO_GEOMETRY_ARRAY DETERMINISTIC AS
```

```

type          cursor_type is REF CURSOR;
query_crs     cursor_type ;
g             SDO_GEOMETRY;
GeometryArr   SDO_GEOMETRY_ARRAY;
where_clause  VARCHAR2(2000);
BEGIN
  IF predicate IS NULL
  THEN
    where_clause := NULL;
  ELSE
    where_clause := ' WHERE ';
  END IF;

  GeometryArr := SDO_GEOMETRY_ARRAY();
  OPEN query_crs FOR ' SELECT ' || column_name ||
                    ' FROM ' || table_name ||
                    where_clause || predicate;

  LOOP
    FETCH query_crs into g;
    EXIT when query_crs%NOTFOUND ;
    GeometryArr.extend;
    GeometryArr(GeometryArr.count) := g;
  END LOOP;
  RETURN GeometryArr;
END;
/

SELECT sdo_aggr_set_union (get_geom_set ('COLA_MARKETS', 'SHAPE',
    'name <> ''cola_c'''), .0005 ) FROM dual;

SDO_AGGR_SET_UNION(GET_GEOM_SET('COLA_MARKETS', 'SHAPE', 'NAME<>' 'COLA_C'), .0005
-----
SDO_GEOMETRY(2007, NULL, NULL, SDO_ELEM_INFO_ARRAY(1, 1003, 2, 11, 1003, 1), SDO
_ORDINATE_ARRAY(8, 11, 6, 9, 8, 7, 10, 9, 8, 11, 1, 7, 1, 1, 5, 1, 8, 1, 8, 6, 5
, 7, 1, 7))

```

SDO_AGGR_UNION

Format

```
SDO_AGGR_UNION(
    AggregateGeometry SDOAGGRTYPE
) RETURN SDO_GEOMETRY;
```

Description

Returns a geometry object that is the topological union (OR operation) of the specified geometry objects.

Parameters

AggregateGeometry

An object of type SDOAGGRTYPE (see [Section 1.10.1](#)) that specifies the geometry column and dimensional array.

Usage Notes

Do not use SDO_AGGR_UNION to merge line string or multiline string geometries; instead, use the [SDO_AGGR_CONCAT_LINES](#) spatial aggregate function.

See also the information about the [SDO_GEOM.SDO_UNION](#) function in [Chapter 24](#).

Examples

The following example returns the union of all geometries except cola_d (in this case, cola_a, cola_b, and cola_c). (The example uses the definitions and data from [Section 2.1](#).)

```
SELECT SDO_AGGR_UNION(
    SDOAGGRTYPE(c.shape, 0.005))
FROM cola_markets c
WHERE c.name <> 'cola_d';

SDO_AGGR_UNION(SDOAGGRTYPE(C.SHAPE,0.005))(SDO_GTYPE, SDO_SRID, SDO_POINT(
-----
SDO_GEOMETRY(2007, NULL, NULL, SDO_ELEM_INFO_ARRAY(1, 1003, 2, 11, 1003, 1), SDO
_ORDINATE_ARRAY(8, 11, 6, 9, 8, 7, 10, 9, 8, 11, 1, 7, 1, 1, 5, 1, 8, 1, 8, 6, 5
, 7, 1, 7))
```

See also the more complex SDO_AGGR_UNION example in [Section C.4](#).

SDO_CS Package (Coordinate System Transformation)

The MDSYS.SDO_CS package contains subprograms for working with coordinate systems. You can perform explicit coordinate transformations on a single geometry or an entire layer of geometries (that is, all geometries in a specified column in a table).

To use the subprograms in this chapter, you must understand the conceptual information about coordinate systems in [Section 1.5.4](#) and [Chapter 6](#).

[Table 21-1](#) lists the coordinate system transformation subprograms.

Table 21-1 Subprograms for Coordinate System Transformation

Subprogram	Description
SDO_CS.ADD_PREFERENCE_FOR_OP	Adds a preference for an operation between a source coordinate system and a target coordinate system.
SDO_CS.CONVERT_NADCON_TO_XML	Converts a NADCON (North American Datum Conversion) grid in ASCII format to an Oracle Spatial XML representation.
SDO_CS.CONVERT_NTV2_TO_XML	Converts an NTv2 (National Transformation Version 2) grid in ASCII format to an Oracle Spatial XML representation.
SDO_CS.CONVERT_XML_TO_NADCON	Converts an Oracle Spatial XML representation of a NADCON (North American Datum Conversion) grid to NADCON ASCII format.
SDO_CS.CONVERT_XML_TO_NTV2	Converts an Oracle Spatial XML representation of an NTv2 (National Transformation Version 2) grid to NTv2 ASCII format.
SDO_CS.CREATE_CONCATENATED_OP	Creates a concatenated operation.
SDO_CS.CREATE_OBVIOUS_EPSG_RULES	Creates a basic set of EPSG rules to be applied in certain transformations.
SDO_CS.CREATE_PREF_CONCATENATED_OP	Creates a concatenated operation, associating it with a transformation plan and making it preferred either systemwide or for a specified use case.
SDO_CS.DELETE_ALL_EPSG_RULES	Deletes the basic set of EPSG rules to be applied in certain transformations.
SDO_CS.DELETE_OP	Deletes a concatenated operation.

Table 21–1 (Cont.) Subprograms for Coordinate System Transformation

Subprogram	Description
SDO_CS.DETERMINE_CHAIN	Returns the query chain, based on the system rule set, to be used in transformations from one coordinate reference system to another coordinate reference system.
SDO_CS.DETERMINE_DEFAULT_CHAIN	Returns the default chain of SRID values in transformations from one coordinate reference system to another coordinate reference system.
SDO_CS.FIND_GEOG_CRS	Returns the SRID values of geodetic (geographic) coordinate reference systems that have the same well-known text (WKT) numeric values as the coordinate reference system with the specified reference SRID value.
SDO_CS.FIND_PROJ_CRS	Returns the SRID values of projected coordinate reference systems that have the same well-known text (WKT) numeric values as the coordinate reference system with the specified reference SRID value.
SDO_CS.FIND_SRID	Finds an SRID value for a coordinate system that matches information that you specify.
SDO_CS.FROM_OGC_SIMPLEFEATURE_SRS	Converts a well-known text string from the Open Geospatial Consortium simple feature format without the TOWGS84 keyword to the format that includes the TOWGS84 keyword.
SDO_CS.FROM_USNG	Converts a point represented in U.S. National Grid format to a spatial point geometry object.
SDO_CS.GET_EPSG_DATA_VERSION	Gets the version number of the EPSG dataset used by Spatial.
SDO_CS.MAKE_2D	Converts a three-dimensional geometry into a two-dimensional geometry.
SDO_CS.MAKE_3D	Converts a two-dimensional geometry into a three-dimensional geometry.
SDO_CS.MAP_EPSG_SRID_TO_ORACLE	Returns the Oracle Spatial SRID values corresponding to the specified EPSG SRID value.
SDO_CS.MAP_ORACLE_SRID_TO_EPSG	Returns the EPSG SRID value corresponding to the specified Oracle Spatial SRID value.
SDO_CS.REVOKE_PREFERENCE_FOR_OP	Revokes a preference for an operation between a source coordinate system and a target coordinate system.
SDO_CS.TO_OGC_SIMPLEFEATURE_SRS	Converts a well-known text string from the Open Geospatial Consortium simple feature format that includes the TOWGS84 keyword to the format without the TOWGS84 keyword.
SDO_CS.TRANSFORM	Transforms a geometry representation using a coordinate system (specified by SRID or name).
SDO_CS.TRANSFORM_LAYER	Transforms an entire layer of geometries (that is, all geometries in a specified column in a table).
SDO_CS.UPDATE_WKTS_FOR_ALL_EPSG_CRS	Updates the well-known text (WKT) description for all EPSG coordinate reference systems.
SDO_CS.UPDATE_WKTS_FOR_EPSG_CRS	Updates the well-known text (WKT) description for the EPSG coordinate reference system associated with a specified SRID.

Table 21–1 (Cont.) Subprograms for Coordinate System Transformation

Subprogram	Description
<code>SDO_CS.UPDATE_WKTS_FOR_EPSG_DATUM</code>	Updates the well-known text (WKT) description for all EPSG coordinate reference systems associated with a specified datum.
<code>SDO_CS.UPDATE_WKTS_FOR_EPSG_ELLIPS</code>	Updates the well-known text (WKT) description for all EPSG coordinate reference systems associated with a specified ellipsoid.
<code>SDO_CS.UPDATE_WKTS_FOR_EPSG_OP</code>	Updates the well-known text (WKT) description for all EPSG coordinate reference systems associated with a specified coordinate transformation operation.
<code>SDO_CS.UPDATE_WKTS_FOR_EPSG_PARAM</code>	Updates the well-known text (WKT) description for all EPSG coordinate reference systems associated with a specified coordinate transformation operation and parameter for transformation operations.
<code>SDO_CS.UPDATE_WKTS_FOR_EPSG_PM</code>	Updates the well-known text (WKT) description for all EPSG coordinate reference systems associated with a specified prime meridian.
<code>SDO_CS.VALIDATE_WKT</code>	Validates the well-known text (WKT) description associated with a specified SRID.

The rest of this chapter provides reference information on the subprograms, listed in alphabetical order.

SDO_CS.ADD_PREFERENCE_FOR_OP

Format

```
SDO_CS.ADD_PREFERENCE_FOR_OP(  
    op_id      IN NUMBER,  
    source_crs IN NUMBER DEFAULT NULL,  
    target_crs IN NUMBER DEFAULT NULL,  
    use_case   IN VARCHAR2 DEFAULT NULL);
```

Description

Adds a preference for an operation between a source coordinate system and a target coordinate system.

Parameters

op_id

ID number of the operation. Must be a value in the COORD_OP_ID column of the SDO_COORD_OPS table (described in [Section 6.7.8](#)).

source_crs

The SRID of the source coordinate reference system. Must be null or a value in the SRID column of the SDO_COORD_REF_SYS table (described in [Section 6.7.9](#)).

target_crs

The SRID of the target coordinate reference system. Must be null or a value in the SRID column of the SDO_COORD_REF_SYS table (described in [Section 6.7.9](#)).

use_case

Name of the use case to be associated with this preference. Must be null or a value from the USE_CASE column of the SDO_PREFERRED_OPS_USER table (described in [Section 6.7.25](#)).

Usage Notes

If `use_case` is null, the transformation plan associated with the operation is a systemwide preference, and a row is added (or two rows are added if a reverse operation exists) to the SDO_PREFERRED_OPS_SYSTEM table (described in [Section 6.7.24](#)). If `use_case` is not null, the transformation plan associated with the operation is a preference associated with the specified use case, and a row is added (or two rows are added if a reverse operation exists) to the SDO_PREFERRED_OPS_USER table (described in [Section 6.7.25](#)).

To create a concatenated operation and make it preferred either systemwide or for a specified use case, you can use the [SDO_CS.CREATE_PREF_CONCATENATED_OP](#) convenience procedure.

To revoke a preference for an operation between a source coordinate system and a target coordinate system, use the [SDO_CS.REVOKE_PREFERENCE_FOR_OP](#) procedure.

Examples

The following example adds a preference for operation 19977 to be used in transformations from SRID 4301 to SRID 4326 when use case use_case_B is specified for the transformation.

```
EXECUTE SDO_CS.ADD_PREFERENCE_FOR_OP(19977, 4301, 4326, 'use_case_B');
```

SDO_CS.CONVERT_NADCON_TO_XML

Format

```
SDO_CS.CONVERT_NADCON_TO_XML(  
    laa_clob IN CLOB,  
    loa_clob IN CLOB,  
    xml_grid OUT XMLTYPE );
```

Description

Converts a NADCON (North American Datum Conversion) grid in ASCII format to an Oracle Spatial XML representation.

Parameters

laa_clob

Latitude values of the NADCON grid in a CLOB object.

loa_clob

Longitude values of the NADCON grid in a CLOB object.

xml_grid

Output XML document containing the Oracle Spatial XML representation of the NADCON grid.

Usage Notes

To convert an Oracle Spatial XML representation to a NADCON grid, use the [SDO_CS.CONVERT_XML_TO_NADCON](#) procedure.

Examples

The following example converts a NADCON grid in ASCII format to an Oracle Spatial XML representation, converts the resulting XML representation back to a NADCON ASCII representation, and displays the resulting ASCII representation. (Only part of the output is shown.)

```
set lines 32000  
set long 2000000000  
  
DECLARE  
    laa      CLOB;  
    loa      CLOB;  
    xml      XMLTYPE;  
    laa_file BFILE;  
    loa_file BFILE;  
BEGIN  
    laa_file := BFILENAME('MY_WORK_DIR', 'samplenadcon.laa');  
    loa_file := BFILENAME('MY_WORK_DIR', 'samplenadcon.loa');  
    DBMS_LOB.OPEN(laa_file, DBMS_LOB.LOB_READONLY);  
    DBMS_LOB.OPEN(loa_file, DBMS_LOB.LOB_READONLY);  
  
    DBMS_LOB.CREATETEMPORARY(laa, TRUE, DBMS_LOB.SESION);  
    DBMS_LOB.CREATETEMPORARY(loa, TRUE, DBMS_LOB.SESION);  
    DBMS_LOB.OPEN(laa, DBMS_LOB.LOB_READWRITE);
```

```

DBMS_LOB.OPEN(lob, DBMS_LOB.LOB_READWRITE);
DBMS_LOB.LOADFROMFILE(lob, lob_file, DBMS_LOB.LOBMAXSIZE);
DBMS_LOB.LOADFROMFILE(lob, lob_file, DBMS_LOB.LOBMAXSIZE);
DBMS_LOB.CLOSE(lob);
DBMS_LOB.CLOSE(lob);
DBMS_LOB.CLOSE(lob_file);
DBMS_LOB.CLOSE(lob_file);

SDO_CS.convert_NADCON_to_XML(lob, lob, xml);
SDO_CS.convert_XML_to_NADCON(xml, lob, lob);
DBMS_OUTPUT.PUT_LINE(SUBSTR(lob, 1, 32000));
DBMS_OUTPUT.PUT_LINE(SUBSTR(lob, 1, 32000));
END;
/
NADCON EXTRACTED REGION                                NADGRD
33 49 1 -107.00000      .25000    25.00000      .25000      .00000
      .006731      .006444      .006208      .006036      .005935      .005904
      .005932      .006002      .006092      .006174      .006218      .006198
      .006087      .005867      .005522      .005045      .004432      .003688
      .002818      .001836      .000759      -.000385      -.001559      -.002704
. . .
NADCON EXTRACTED REGION                                NADGRD
33 49 1 -107.00000      .25000    25.00000      .25000      .00000
      .008509      .007147      .005756      .004331      .002879      .001410
      -.000060      -.001507      -.002904      -.004222      -.005431      -.006498
      -.007395      -.008095      -.008579      -.008832      -.008848      -.008632
      -.008200      -.007577      -.006800      -.005911      -.004957      -.003974
. . .

```

SDO_CS.CONVERT_NTV2_TO_XML

Format

```
SDO_CS.CONVERT_NTV2_TO_XML(  
    ntv2_clob IN CLOB,  
    xml_grid OUT XMLTYPE );
```

Description

Converts an NTv2 (National Transformation Version 2) grid in ASCII format to an Oracle Spatial XML representation.

Parameters

ntv2_clob

NTv2 grid values in a CLOB object.

xml_grid

Output XML document containing the Oracle Spatial XML representation of the NTv2 grid.

Usage Notes

To convert an Oracle Spatial XML representation to an NTv2 grid, use the [SDO_CS.CONVERT_XML_TO_NTV2](#) procedure.

Examples

The following example converts an NTv2 grid in ASCII format to an Oracle Spatial XML representation, converts the resulting XML representation back to an NTv2 ASCII representation, and displays the resulting ASCII representation. (Only part of the output is shown.)

```
set lines 32000  
set long 2000000000  
  
DECLARE  
    ntv2          CLOB;  
    xml           XMLTYPE;  
    ntv2_file     BFILE;  
BEGIN  
    ntv2_file := BFILENAME('MY_WORK_DIR', 'samplentv2.gsa');  
    DBMS_LOB.OPEN(ntv2_file, DBMS_LOB.LOB_READONLY);  
  
    DBMS_LOB.CREATETEMPORARY(ntv2, TRUE, DBMS_LOB.SESSION);  
    DBMS_LOB.OPEN(ntv2, DBMS_LOB.LOB_READWRITE);  
    DBMS_LOB.LOADFROMFILE(ntv2, ntv2_file, DBMS_LOB.LOBMAXSIZE);  
    DBMS_LOB.CLOSE(ntv2);  
    DBMS_LOB.CLOSE(ntv2_file);  
  
    SDO_CS.convert_NTV2_to_XML(ntv2, xml);  
    SDO_CS.convert_XML_to_NTV2(xml, ntv2);  
    DBMS_OUTPUT.PUT_LINE(SUBSTR(ntv2, 1, 32000));  
END;  
/  
NUM_OREC 11
```

```
NUM_SREC 11
NUM_FILE 2
GS_TYPE SECONDS
VERSION NTv2.0
DATUM_F NAD27
DATUM_T NAD83
MAJOR_F 6378206.400
MINOR_F 6356583.800
MAJOR_T 6378137.000
MINOR_T 6356752.314
SUB_NAMEALbanff
PARENT NONE
CREATED 95-06-29
UPDATED 95-07-04
S_LAT 183900.000000
N_LAT 184500.000000
E_LONG 415800.000000
W_LONG 416100.000000
LAT_INC 30.000000
LONG_INC 30.000000
GS_COUNT 231
0.084020 3.737300 0.005000 0.008000
0.083029 3.738740 0.017000 0.011000
0.082038 3.740180 0.029000 0.015000
. . .
```

SDO_CS.CONVERT_XML_TO_NADCON

Format

```
SDO_CS.CONVERT_XML_TO_NADCON(  
    xml_grid IN XMLTYPE,  
    laa_clob OUT CLOB,  
    loa_clob OUT CLOB);
```

Description

Converts an Oracle Spatial XML representation of a NADCON (North American Datum Conversion) grid to NADCON ASCII format.

Parameters

xml_grid

XML document containing the Oracle Spatial XML representation of the NADCON grid.

laa_clob

Output CLOB object containing the latitude values of the NADCON grid.

loa_clob

Output CLOB object containing the longitude values of the NADCON grid.

Usage Notes

To convert a NADCON grid in ASCII format to an Oracle Spatial XML representation, use the [SDO_CS.CONVERT_NADCON_TO_XML](#) procedure.

Examples

The following example converts a NADCON grid in ASCII format to an Oracle Spatial XML representation, converts the resulting XML representation back to a NADCON ASCII representation, and displays the resulting ASCII representation. (Only part of the output is shown.)

```
set lines 32000  
set long 2000000000  
  
DECLARE  
    laa      CLOB;  
    loa      CLOB;  
    xml      XMLTYPE;  
    laa_file BFILE;  
    loa_file BFILE;  
BEGIN  
    laa_file := BFILENAME('MY_WORK_DIR', 'samplenadcon.laa');  
    loa_file := BFILENAME('MY_WORK_DIR', 'samplenadcon.loa');  
    DBMS_LOB.OPEN(laa_file, DBMS_LOB.LOB_READONLY);  
    DBMS_LOB.OPEN(loa_file, DBMS_LOB.LOB_READONLY);  
  
    DBMS_LOB.CREATETEMPORARY(laa, TRUE, DBMS_LOB.SESSTION);  
    DBMS_LOB.CREATETEMPORARY(loa, TRUE, DBMS_LOB.SESSTION);  
    DBMS_LOB.OPEN(laa, DBMS_LOB.LOB_READWRITE);
```



```

DBMS_LOB.OPEN(lob, DBMS_LOB.LOB_READWRITE);
DBMS_LOB.LOADFROMFILE(lob, lob_file, DBMS_LOB.LOBMAXSIZE);
DBMS_LOB.LOADFROMFILE(lob, lob_file, DBMS_LOB.LOBMAXSIZE);
DBMS_LOB.CLOSE(lob);
DBMS_LOB.CLOSE(lob);
DBMS_LOB.CLOSE(lob_file);
DBMS_LOB.CLOSE(lob_file);

SDO_CS.convert_NADCON_to_XML(lob, lob, xml);
SDO_CS.convert_XML_to_NADCON(xml, lob, lob);
DBMS_OUTPUT.PUT_LINE(SUBSTR(lob, 1, 32000));
DBMS_OUTPUT.PUT_LINE(SUBSTR(lob, 1, 32000));
END;
/
NADCON EXTRACTED REGION                                NADGRD
33 49 1 -107.00000      .25000    25.00000      .25000      .00000
      .006731      .006444      .006208      .006036      .005935      .005904
      .005932      .006002      .006092      .006174      .006218      .006198
      .006087      .005867      .005522      .005045      .004432      .003688
      .002818      .001836      .000759      -.000385      -.001559      -.002704
. . .
NADCON EXTRACTED REGION                                NADGRD
33 49 1 -107.00000      .25000    25.00000      .25000      .00000
      .008509      .007147      .005756      .004331      .002879      .001410
      -.000060      -.001507      -.002904      -.004222      -.005431      -.006498
      -.007395      -.008095      -.008579      -.008832      -.008848      -.008632
      -.008200      -.007577      -.006800      -.005911      -.004957      -.003974
. . .

```

SDO_CS.CONVERT_XML_TO_NTV2

Format

```
SDO_CS.CONVERT_XML_TO_NTV2(  
    xml_grid IN XMLTYPE,  
    ntv2_clob OUT CLOB);
```

Description

Converts an Oracle Spatial XML representation of an NTV2 (National Transformation Version 2) grid to NTV2 ASCII format.

Parameters

xml_grid

XML document containing the Oracle Spatial XML representation of the NTV2 grid.

ntv2_clob

Output CLOB object containing the values for the NTV2 grid.

Usage Notes

To convert an NTV2 grid in ASCII format to an Oracle Spatial XML representation, use the [SDO_CS.CONVERT_NTV2_TO_XML](#) procedure.

Examples

The following example converts an NTV2 grid in ASCII format to an Oracle Spatial XML representation, converts the resulting XML representation back to an NTV2 ASCII representation, and displays the resulting ASCII representation. (Only part of the output is shown.)

```
set lines 32000  
set long 2000000000  
  
DECLARE  
    ntv2          CLOB;  
    xml           XMLTYPE;  
    ntv2_file     BFILE;  
BEGIN  
    ntv2_file := BFILENAME('MY_WORK_DIR', 'samplentv2.gsa');  
    DBMS_LOB.OPEN(ntv2_file, DBMS_LOB.LOB_READONLY);  
  
    DBMS_LOB.CREATETEMPORARY(ntv2, TRUE, DBMS_LOB.SESSION);  
    DBMS_LOB.OPEN(ntv2, DBMS_LOB.LOB_READWRITE);  
    DBMS_LOB.LOADFROMFILE(ntv2, ntv2_file, DBMS_LOB.LOBMAXSIZE);  
    DBMS_LOB.CLOSE(ntv2);  
    DBMS_LOB.CLOSE(ntv2_file);  
  
    SDO_CS.convert_NTV2_to_XML(ntv2, xml);  
    SDO_CS.convert_XML_to_NTV2(xml, ntv2);  
    DBMS_OUTPUT.PUT_LINE(SUBSTR(ntv2, 1, 32000));  
END;  
/  
NUM_OREC 11  
NUM_SREC 11
```

```
NUM_FILE 2
GS_TYPE SECONDS
VERSION NTv2.0
DATUM_F NAD27
DATUM_T NAD83
MAJOR_F 6378206.400
MINOR_F 6356583.800
MAJOR_T 6378137.000
MINOR_T 6356752.314
SUB_NAMEALbanff
PARENT NONE
CREATED 95-06-29
UPDATED 95-07-04
S_LAT 183900.000000
N_LAT 184500.000000
E_LONG 415800.000000
W_LONG 416100.000000
LAT_INC 30.000000
LONG_INC 30.000000
GS_COUNT 231
  0.084020 3.737300 0.005000 0.008000
  0.083029 3.738740 0.017000 0.011000
  0.082038 3.740180 0.029000 0.015000
. . .
```

SDO_CS.CREATE_CONCATENATED_OP

Format

```
SDO_CS.CREATE_CONCATENATED_OP(  
    op_id    IN NUMBER,  
    op_name  IN VARCHAR2,  
    use_plan IN TFM_PLAN);
```

Description

Creates a concatenated operation.

Parameters

op_id

ID number of the concatenated operation.

op_name

Name to be associated with the concatenated operation.

use_plan

Transformation plan. The TFM_PLAN object type is explained in [Section 6.6](#).

Usage Notes

A concatenated operation is the concatenation (chaining) of two or more atomic operations.

To create a concatenated operation and make it preferred either systemwide or for a specified use case, you can use the [SDO_CS.CREATE_PREF_CONCATENATED_OP](#) convenience procedure.

Examples

The following example creates a concatenation operation with the operation ID 2999 and the name `CONCATENATED_OPERATION_2999`.

```
DECLARE  
BEGIN  
SDO_CS.CREATE_CONCATENATED_OP(  
    2999,  
    'CONCATENATED_OPERATION_2999',  
    TFM_PLAN(SDO_TFM_CHAIN(4242, 19910, 24200, 1000000000, 24200)));  
END;  
/
```

SDO_CS.CREATE_OBVIOUS_EPSG_RULES

Format

```
SDO_CS.CREATE_OBVIOUS_EPSG_RULES(  
    use_case IN VARCHAR2 DEFAULT NULL);
```

Description

Creates a basic set of EPSG rules to be applied in certain transformations.

Parameters

use_case

Name of the use case to be associated with the application of the EPSG rules that are created. Must be a value from the USE_CASE column of the SDO_PREFERRED_OPS_USER table (described in [Section 6.7.25](#)).

Usage Notes

This procedure creates rules to implement the main EPSG-defined transformations between specific coordinate reference systems. For transformations between some coordinate reference systems, EPSG has specified rules that should be applied. For any given transformation from one coordinate reference system to another, the EPSG rule might be different from the default Oracle Spatial rule. If you execute this procedure, the EPSG rules are applied in any such cases. If you do not execute this procedure, the default Spatial rules are used in such cases.

This procedure inserts many rows into the SDO_PREFERRED_OPS_SYSTEM table (see [Section 6.7.24](#)).

To delete the EPSG rules created by this procedure, and thus cause the default Spatial rules to be used in all cases, use the [SDO_CS.DELETE_ALL_EPSG_RULES](#) procedure.

Examples

The following example creates a basic set of EPSG rules to be applied in certain transformations.

```
EXECUTE SDO_CS.CREATE_OBVIOUS_EPSG_RULES;
```

SDO_CS.CREATE_PREF_CONCATENATED_OP

Format

```
SDO_CS.CREATE_PREF_CONCATENATED_OP(  
    op_id    IN NUMBER,  
    op_name  IN VARCHAR2,  
    use_plan IN TFM_PLAN,  
    use_case IN VARCHAR2 DEFAULT NULL);
```

Description

Creates a concatenated operation, associating it with a transformation plan and making it preferred either systemwide or for a specified use case.

Parameters

op_id

ID number of the concatenated operation to be created.

op_name

Name to be associated with the concatenated operation.

use_plan

Transformation plan. The TFM_PLAN object type is explained in [Section 6.6](#).

use_case

Use case to which this preferred concatenated operation applies. Must be a null or a value from the USE_CASE column of the SDO_PREFERRED_OPS_USER table (described in [Section 6.7.25](#)).

Usage Notes

This convenience procedure combines the operations of the [SDO_CS.CREATE_CONCATENATED_OP](#) and [SDO_CS.ADD_PREFERENCE_FOR_OP](#) procedures.

A concatenated operation is the concatenation (chaining) of two or more atomic operations.

If `use_case` is null, the transformation plan associated with the operation is a systemwide preference, and a row is added (or two rows are added if a reverse operation exists) to the SDO_PREFERRED_OPS_SYSTEM table (described in [Section 6.7.24](#)). If `use_case` is not null, the transformation plan associated with the operation is a preference associated with the specified use case, and a row is added (or two rows are added if a reverse operation exists) to the SDO_PREFERRED_OPS_USER table (described in [Section 6.7.25](#)).

To create a concatenation without making it preferred either systemwide or for a specified use case, use the [SDO_CS.CREATE_CONCATENATED_OP](#) procedure

To delete a concatenated operation, use the [SDO_CS.DELETE_OP](#) procedure.

Examples

The following example creates a concatenation operation with the operation ID 300 and the name MY_CONCATENATION_OPERATION, and causes Spatial to use the

specified transformation plan in all cases (because use_case is null) when this operation is used.

```
DECLARE
BEGIN
SDO_CS.CREATE_PREF_CONCATENATED_OP(
  300,
  'MY_CONCATENATED_OPERATION',
  TFM_PLAN(SDO_TFM_CHAIN(4242, 19910, 24200, 1000000000, 24200)),
  NULL);
END;
/
```

SDO_CS.DELETE_ALL_EPSG_RULES

Format

```
SDO_CS.DELETE_ALL_EPSG_RULES(  
    use_case IN VARCHAR2 DEFAULT NULL);
```

Description

Deletes the basic set of EPSG rules to be applied in certain transformations.

Parameters

use_case

Name of the use case to be associated with the application of the EPSG rules that are created. Must match the value that was used for the `use_case` parameter value (either null or a specified value) when the [SDO_CS.CREATE_OBVIOUS_EPSG_RULES](#) procedure was called.

Usage Notes

This procedure deletes the EPSG rules that were previously created by the [SDO_CS.CREATE_OBVIOUS_EPSG_RULES](#) procedure, and thus causes the default Spatial rules to be used in all cases. (See the Usage Notes for the [SDO_CS.CREATE_OBVIOUS_EPSG_RULES](#) procedure for more information.)

If `use_case` is null, this procedure deletes all rows from the `SDO_PREFERRED_OPS_SYSTEM` table (see [Section 6.7.24](#)). If `use_case` is not null, this procedure deletes the rows associated with the specified use case from the `SDO_PREFERRED_OPS_USER` table (see [Section 6.7.25](#)).

Examples

The following example deletes the basic set of EPSG rules to be applied in certain transformations.

```
EXECUTE SDO_CS.DELETE_ALL_EPSG_RULES;
```

SDO_CS.DELETE_OP

Format

```
SDO_CS.DELETE_OP(  
    op_id IN NUMBER);
```

Description

Deletes a concatenated operation.

Parameters

op_id
ID number of the operation to be deleted.

Usage Notes

To create a concatenated operation and make it preferred systemwide or only for a specified use case, use the [SDO_CS.CREATE_CONCATENATED_OP](#) procedure.

Examples

The following example deletes the operation with the ID number 300.

```
EXECUTE SDO_CS.DELETE_OP(300);
```

SDO_CS.DETERMINE_CHAIN

Format

```
SDO_CS.DETERMINE_CHAIN(
    transient_rule_set IN SDO_TRANSIENT_RULE_SET,
    use_case           IN VARCHAR2,
    source_srid       IN NUMBER,
    target_srid       IN NUMBER) RETURN TFM_PLAN;
```

Description

Returns the query chain, based on the system rule set, to be used in transformations from one coordinate reference system to another coordinate reference system.

Parameters

transient_rule_set

Rule set to be used for the transformation. If you specify a null value, the Oracle system rule set is used.

use_case

Use case for which to determine the query chain. Must be a null value or a value from the USE_CASE column of the SDO_PREFERRED_OPS_USER table (described in [Section 6.7.25](#)).

source_srid

The SRID of the source coordinate reference system. Must be a value in the SRID column of the SDO_COORD_REF_SYS table (described in [Section 6.7.9](#)).

target_srid

The SRID of the target coordinate reference system. Must be a value in the SRID column of the SDO_COORD_REF_SYS table (described in [Section 6.7.9](#)).

Usage Notes

This function returns an object of type TFM_PLAN, which is explained in [Section 6.6](#).

The transient_rule_set parameter is of type SDO_TRANSIENT_RULE_SET, which has the following definition:

```
CREATE TYPE sdo_transient_rule_set AS OBJECT (
    source_srid NUMBER,
    target_srid NUMBER,
    tfm          NUMBER);
```

Examples

The following example returns the query chain based on the system rule set.

```
SELECT MDSYS.SDO_CS.DETERMINE_CHAIN(NULL, NULL, 4804, 4257) FROM DUAL;
```

```
MDSYS.SDO_CS.DETERMINE_CHAIN(NULL, NULL, 4804, 4257) (THE_PLAN)
```

```
-----
TFM_PLAN(SDO_TFM_CHAIN(4804, -2, 4257))
```

The next example creates a preferred concatenated operation (with operation ID 300) with a specified chain for transformations from SRID 4804 to SRID 4257, and then calls the DETERMINE_CHAIN function, returning a different result. (The operation created in this example is not meaningful or useful, and it was created only for illustration.)

```
CALL SDO_CS.CREATE_PREF_CONCATENATED_OP(
  300,
  'CONCATENATED OPERATION',
  TFM_PLAN(
    SDO_TFM_CHAIN(
      4804,
      1000000001, 4804,
      1000000002, 4804,
      1000000001, 4804,
      1000000001, 4804,
      1000000002, 4804,
      1000000002, 4804,
      1000000002, 4804,
      1000000001, 4804,
      1000000001, 4804,
      1000000001, 4804,
      1000000002, 4804,
      1000000002, 4804,
      1000000002, 4257)),
  NULL);

SELECT MDSYS.SDO_CS.DETERMINE_CHAIN(NULL, NULL, 4804, 4257) FROM DUAL;

MDSYS.SDO_CS.DETERMINE_CHAIN(NULL, NULL, 4804, 4257) (THE_PLAN)
-----
TFM_PLAN(SDO_TFM_CHAIN(4804, 300, 4257))
```

SDO_CS.DETERMINE_DEFAULT_CHAIN

Format

```
SDO_CS.DETERMINE_DEFAULT_CHAIN(  
    source_srid IN NUMBER,  
    target_srid IN NUMBER) RETURN SDO_SRID_CHAIN;
```

Description

Returns the default chain of SRID values in transformations from one coordinate reference system to another coordinate reference system.

Parameters

source_srid

The SRID of the source coordinate reference system. Must be a value in the SRID column of the SDO_COORD_REF_SYS table (described in [Section 6.7.9](#)).

target_srid

The SRID of the target coordinate reference system. Must be a value in the SRID column of the SDO_COORD_REF_SYS table (described in [Section 6.7.9](#)).

Usage Notes

This function returns an object of type SDO_SRID_CHAIN, which is defined as VARRAY(1048576) OF NUMBER.

Examples

The following example returns the default chain of SRID values in transformations from SRID 4804 to SRID 4257.

```
SELECT MDSYS.SDO_CS.DETERMINE_DEFAULT_CHAIN(4804, 4257) FROM DUAL;
```

```
MDSYS.SDO_CS.DETERMINE_DEFAULT_CHAIN(4804, 4257)
```

```
-----  
SDO_SRID_CHAIN(NULL, 4804, 4257, NULL)
```

SDO_CS.FIND_GEOG_CRSS

Format

```
SDO_CS.FIND_GEOG_CRSS(
    reference_srid      IN NUMBER,
    is_legacy           IN VARCHAR2,
    max_rel_num_difference IN NUMBER DEFAULT 0.000001) RETURN SDO_SRID_LIST;
```

Description

Returns the SRID values of geodetic (geographic) coordinate reference systems that have the same well-known text (WKT) numeric values as the coordinate reference system with the specified reference SRID value.

Parameters

reference_srid

The SRID of the coordinate reference system for which to find all other geodetic coordinate reference systems that have the same WKT numeric values. Must be a value in the SRID column of the SDO_COORD_REF_SYS table (described in [Section 6.7.9](#)).

is_legacy

TRUE limits the results to geodetic coordinate reference systems for which the IS_LEGACY column value is TRUE in the SDO_COORD_REF_SYS table (described in [Section 6.7.9](#)); FALSE limits the results to geodetic coordinate reference systems for which the IS_LEGACY column value is FALSE in the SDO_COORD_REF_SYS table. If you specify a null value for this parameter, the IS_LEGACY column value in the SDO_COORD_REF_SYS table is ignored in determining the results.

max_rel_num_difference

A numeric value indicating how closely WKT values must match in order for a projected coordinate reference system to be considered a match. The default value is 0.000001. The value for each numeric WKT item is compared with its corresponding value in the WKT for the reference SRID or in the specified list of parameters to this function; and if the difference in all cases is less than or equal to the max_rel_num_difference value, the SRID for that coordinate reference system is included in the results.

Usage Notes

This function returns an object of type SDO_SRID_LIST, which is defined as VARRAY(1048576) OF NUMBER.

The well-known text (WKT) format is described in [Section 6.8.1.1](#).

Examples

The following examples show the effect of the is_legacy parameter value on the results. The first example returns the SRID values of all geodetic legacy coordinate reference systems that have the same WKT numeric values as the coordinate reference system with the SRID value of 8307.

```
SELECT SDO_CS.FIND_GEOG_CRSS(
```

```
8307,
'TRUE') FROM DUAL;
```

```
SDO_CS.FIND_GEOG_CRS(8307, 'TRUE')
```

```
-----
SDO_SRID_LIST(8192, 8265, 8307, 8311, 8320, 524288, 2000002, 2000006, 2000012, 2000015, 2000023, 2000028)
```

The next example returns the SRID values of all geodetic non-legacy coordinate reference systems that have the same WKT numeric values as the coordinate reference system with the SRID value of 8307.

```
SELECT SDO_CS.FIND_GEOG_CRS(
8307,
'FALSE') FROM DUAL;
```

```
SDO_CS.FIND_GEOG_CRS(8307, 'FALSE')
```

```
-----
SDO_SRID_LIST(4019, 4030, 4031, 4032, 4033, 4041, 4121, 4122, 4126, 4130, 4133, 4140, 4141, 4148, 4151, 4152, 4163, 4166, 4167, 4170, 4171, 4172, 4173, 4176, 4180, 4189, 4190, 4258, 4269, 4283, 4318, 4319, 4326, 4610, 4612, 4617, 4619, 4624, 4627, 4640, 4659, 4661, 4667, 4669, 4670)
```

The next example returns the SRID values of all geodetic coordinate reference systems (legacy and non-legacy) that have the same WKT numeric values as the coordinate reference system with the SRID value of 8307.

```
SELECT SDO_CS.FIND_GEOG_CRS(
8307,
NULL) FROM DUAL;
```

```
SDO_CS.FIND_GEOG_CRS(8307, NULL)
```

```
-----
SDO_SRID_LIST(4019, 4030, 4031, 4032, 4033, 4041, 4121, 4122, 4126, 4130, 4133, 4140, 4141, 4148, 4151, 4152, 4163, 4166, 4167, 4170, 4171, 4172, 4173, 4176, 4180, 4189, 4190, 4258, 4269, 4283, 4318, 4319, 4326, 4610, 4612, 4617, 4619, 4624, 4627, 4640, 4659, 4661, 4667, 4669, 4670, 8192, 8265, 8307, 8311, 8320, 524288, 2000002, 2000006, 2000012, 2000015, 2000023, 2000028)
```

SDO_CS.FIND_PROJ_CR

Format

```
SDO_CS.FIND_PROJ_CR(  
    reference_srid      IN NUMBER,  
    is_legacy           IN VARCHAR2,  
    max_rel_num_difference IN NUMBER DEFAULT 0.000001) RETURN SDO_SRID_LIST;
```

Description

Returns the SRID values of projected coordinate reference systems that have the same well-known text (WKT) numeric values as the coordinate reference system with the specified reference SRID value.

Parameters

reference_srid

The SRID of the coordinate reference system for which to find all other projected coordinate reference systems that have the same WKT numeric values. Must be a value in the SRID column of the SDO_COORD_REF_SYS table (described in [Section 6.7.9](#)).

is_legacy

TRUE limits the results to projected coordinate reference systems for which the IS_LEGACY column value is TRUE in the SDO_COORD_REF_SYS table (described in [Section 6.7.9](#)); FALSE limits the results to projected coordinate reference systems for which the IS_LEGACY column value is FALSE in the SDO_COORD_REF_SYS table. If you specify a null value for this parameter, the IS_LEGACY column value in the SDO_COORD_REF_SYS table is ignored in determining the results.

max_rel_num_difference

A numeric value indicating how closely WKT values must match in order for a coordinate reference system to be considered a match. The default value is 0.000001. The value for each numeric WKT item is compared with its corresponding value in the WKT for the reference SRID or in the specified list of parameters to this function; and if the difference in all cases is less than or equal to the max_rel_num_difference value, the SRID for that coordinate reference system is included in the results.

Usage Notes

This function returns an object of type SDO_SRID_LIST, which is defined as VARRAY(1048576) OF NUMBER.

The well-known text (WKT) format is described in [Section 6.8.1.1](#).

Examples

The following examples show the effect of the is_legacy parameter value on the results. The first example returns the SRID values of all projected legacy coordinate reference systems that have the same WKT numeric values as the coordinate reference system with the SRID value of 2007. The returned result list is empty, because there are no legacy projected legacy coordinate reference systems that meet the search criteria.

```
SELECT SDO_CS.FIND_PROJ_CRS(  
    2007,  
    'TRUE') FROM DUAL;
```

```
SDO_CS.FIND_PROJ_CRS(2007, 'TRUE')
```

```
-----  
SDO_SRID_LIST()
```

The next example returns the SRID values of all projected non-legacy coordinate reference systems that have the same WKT numeric values as the coordinate reference system with the SRID value of 2007.

```
SELECT SDO_CS.FIND_PROJ_CRS(  
    2007,  
    'FALSE') FROM DUAL;
```

```
SDO_CS.FIND_PROJ_CRS(2007, 'FALSE')
```

```
-----  
SDO_SRID_LIST(2000, 2001, 2002, 2003, 2004, 2005, 2006, 2007, 21291)
```

The next example returns the SRID values of all projected coordinate reference systems (legacy and non-legacy) that have the same WKT numeric values as the coordinate reference system with the SRID value of 2007. The returned result list is the same as for the preceding example.

```
SELECT SDO_CS.FIND_PROJ_CRS(  
    2007,  
    NULL) FROM DUAL;
```

```
SDO_CS.FIND_PROJ_CRS(2007, NULL)
```

```
-----  
SDO_SRID_LIST(2000, 2001, 2002, 2003, 2004, 2005, 2006, 2007, 21291)
```

SDO_CS.FIND_SRID

Format

```
SDO_CS.FIND_SRID(
    srid          OUT NUMBER,
    epsg_srid_geog IN NUMBER DEFAULT NULL,
    epsg_srid_proj IN NUMBER DEFAULT NULL,
    datum_id     IN NUMBER DEFAULT NULL,
    pm_id        IN NUMBER DEFAULT NULL,
    proj_method_id IN NUMBER DEFAULT NULL,
    coord_ref_sys_kind IN VARCHAR2 DEFAULT NULL,
    semi_major_axis IN NUMBER DEFAULT NULL,
    semi_minor_axis IN NUMBER DEFAULT NULL,
    inv_flattening IN NUMBER DEFAULT NULL,
    params       IN EPSG_PARAMS DEFAULT NULL);
```

or

```
SDO_CS.FIND_SRID(
    srid          OUT NUMBER,
    epsg_srid_geog IN NUMBER DEFAULT NULL,
    epsg_srid_proj IN NUMBER DEFAULT NULL,
    datum_id     IN NUMBER DEFAULT NULL,
    pm_id        IN NUMBER DEFAULT NULL,
    proj_method_id IN NUMBER DEFAULT NULL,
    proj_op_id    IN NUMBER DEFAULT NULL,
    coord_ref_sys_kind IN VARCHAR2 DEFAULT NULL,
    semi_major_axis IN NUMBER DEFAULT NULL,
    semi_minor_axis IN NUMBER DEFAULT NULL,
    inv_flattening IN NUMBER DEFAULT NULL,
    params       IN EPSG_PARAMS DEFAULT NULL,
    max_rel_num_difference IN NUMBER DEFAULT 0.000001);
```

Description

Finds an SRID value for a coordinate system that matches information that you specify.

Parameters

srid

Output parameter; will contain either a numeric SRID value or a null value, as explained in the Usage Notes.

epsg_srid_geog

EPSG SRID value of a geographic coordinate system. Depending on the value of the `coord_ref_sys_kind` parameter, this procedure will either verify the existence of a coordinate system with this geographic SRID value, or will find an SRID value of a projected coordinate system based on a coordinate system with this SRID value.

epsg_srid_proj

EPSG SRID value of a projected coordinate system.

datum_id

Datum ID value. Depending on the value of the `coord_ref_sys_kind` parameter, this procedure will look for the SRID of a geographic or projected coordinate system based on this datum.

ellipsoid_id

Ellipsoid ID value. Depending on the value of the `coord_ref_sys_kind` parameter, this procedure will look for the SRID of a geographic or projected coordinate system based on this ellipsoid.

pm_id

Prime meridian ID value. Depending on the value of the `coord_ref_sys_kind` parameter, this procedure will look for the SRID of a geographic or projected coordinate system based on this prime meridian.

proj_method_id

Projection method ID value. This procedure will look for the SRID of a projected coordinate system based on this projection method.

proj_op_id

Projection operation ID value. This procedure will look for the SRID of a projected coordinate system based on this projection operation. A projection operation is a projection method combined with specific projection parameters.

coord_ref_sys_kind

The kind or category of coordinate system. Must be a string value in the `COORD_REF_SYS_KIND` column of the `SDO_COORD_REF_SYS` table (described in [Section 6.7.9](#)). Examples: `GEOGRAPHIC2D` and `PROJECTED`

semi_major_axis

Semi-major axis ID value. Depending on the value of the `coord_ref_sys_kind` parameter, this procedure will look for the SRID of a geographic or projected coordinate system based on this semi-major axis.

semi_minor_axis

Semi-minor axis ID value. Depending on the value of the `coord_ref_sys_kind` parameter, this procedure will look for the SRID of a geographic or projected coordinate system based on this semi-minor axis.

inv_flattening

Inverse flattening (unit "unity"). Depending on the value of the `coord_ref_sys_kind` parameter, this procedure will look for the SRID of a geographic or projected coordinate system based on this inverse flattening.

params

Projection parameters. The parameters depend on the projection method. The `EPSG_PARAMS` type is defined as `VARRAY(1048576) OF EPSG_PARAM`, and the `EPSG_PARAM` type is defined as `(id NUMBER, val NUMBER, uom NUMBER)`. The format includes attributes for the parameter ID, value, and unit of measure ID, as shown in the following example:

```
epsg_params (
  epsg_param(8801,      0.0,    9102),
  epsg_param(8802,      9.0,    9102),
  epsg_param(8805,      0.9996, 9201),
  epsg_param(8806, 500000.0,  9001),
  epsg_param(8807,      0.0,    9001));
```

max_rel_num_difference

A numeric value indicating how closely WKT values must match in order for a coordinate reference system to be considered a match. The default value is 0.000001. The value for each numeric WKT item is compared with its corresponding value in the WKT for the reference SRID or in the specified list of parameters to this procedure; and if the difference in all cases is less than or equal to the `max_rel_num_difference` value, the SRID for that coordinate reference system is included in the results.

Usage Notes

This procedure places the result of its operation in the `srid` output parameter. The result is either a numeric SRID value or a null value.

This procedure has the following major uses:

- To check if a coordinate system with a specific SRID value exists. In this case, you specify a value for `epsg_srid_geog` or `epsg_srid_proj` (depending on whether the coordinate system is geographic or projected) and enough parameters for a valid PL/SQL statement. If the resulting `srid` parameter value is the same number as the value that you specified, the coordinate system with that SRID value exists; however, if the resulting `srid` parameter value is null, no coordinate system with that SRID value exists.
- To find the SRID value of a coordinate system based on information that you specify about it.

If multiple coordinate systems match the criteria specified in the input parameters, only one SRID value is returned in the `srid` parameter. This could be any one of the potential matching SRID values, and it is not guaranteed to be the same value in subsequent executions of this procedure with the same input parameters.

Examples

The following example finds an SRID value for a projected coordinate system that uses datum ID 6267 in its definition.

```
DECLARE
  returned_srid NUMBER;
BEGIN
  SDO_CS.FIND_SRID (
```

```
    srid                => returned_srid,  
    epsg_srid_geog     => null,  
    epsg_srid_proj     => null,  
    datum_id          => 6267,  
    ellips_id          => null,  
    pm_id              => null,  
    proj_method_id    => null,  
    proj_op_id        => null,  
    coord_ref_sys_kind => 'PROJECTED');  
DBMS_OUTPUT.PUT_LINE('SRID = ' || returned_srid);  
END;  
/  
SRID = 4267
```

SDO_CS.FROM_OGC_SIMPLEFEATURE_SRS

Format

```
SDO_CS.FROM_OGC_SIMPLEFEATURE_SRS(
    wkt IN VARCHAR2) RETURN VARCHAR2;
```

Description

Converts a well-known text string from the Open Geospatial Consortium simple feature format without the TOWGS84 keyword to the format that includes the TOWGS84 keyword.

Parameters

wkt
Well-known text string.

Usage Notes

To convert a well-known text string from the Open Geospatial Consortium simple feature format that includes the TOWGS84 keyword to the format without the TOWGS84 keyword, use the [SDO_CS.TO_OGC_SIMPLEFEATURE_SRS](#) function.

Examples

The following example converts a well-known text string from the Open Geospatial Consortium simple feature format without the TOWGS84 keyword to the format that includes the TOWGS84 keyword.

```
SELECT sdo_cs.from_OGC_SimpleFeature_SRS('GEOGCS [ "Longitude / Latitude (DHDN)",
    DATUM [ "", SPHEROID ["Bessel 1841", 6377397.155, 299.1528128],
    582.000000, 105.000000, 414.000000, -1.040000, -0.350000, 3.080000, 8.300000 ],
    PRIMEM [ "Greenwich", 0.000000 ], UNIT ["Decimal Degree",
0.01745329251994330]')
FROM DUAL;
```

```
MDSYS.SDO_CS.FROM_OGC_SIMPLEFEATURE_SRS('GEOGCS["LONGITUDE/LATITUDE(DHDN) ", DATUM
-----
GEOGCS [ "Longitude / Latitude (DHDN)", DATUM [ "", SPHEROID ["Bessel 1841", 6377
397.155, 299.1528128], TOWGS84[ 582.000000, 105.000000, 414.000000, -1.040000, -
0.350000, 3.080000, 8.300000]], PRIMEM [ "Greenwich", 0.000000 ], UNIT ["Decimal
Degree", 0.01745329251994330])
```

SDO_CS.FROM_USNG

Format

```
SDO_CS.FROM_USNG(  
    usng IN VARCHAR2,  
    srid IN NUMBER,  
    datum IN VARCHAR2 DEFAULT 'NAD83') RETURN SDO_GEOMETRY;
```

Description

Converts a point represented in U.S. National Grid format to a spatial point geometry object.

Parameters

usng

Well-known text string.

srid

The SRID of the coordinate system to be used for the conversion (that is, the SRID to be used in the returned geometry). Must be a value in the SRID column of the SDO_COORD_REF_SYS table (described in [Section 6.7.9](#)).

datum

The name of the datum on which the U.S. National Grid coordinate for the point is based. Must be either a value in the DATUM_NAME column of the SDO_DATUMS table (described in [Section 6.7.22](#)) or null. The default value is NAD83.

Usage Notes

For information about Oracle Spatial support for the U.S. National Grid, see [Section 6.11](#).

To convert a spatial point geometry to a point represented in U.S. National Grid format, use the [SDO_CS.TO_USNG](#) function.

Examples

The following example converts a point represented in U.S. National Grid format to a spatial geometry point object with longitude/latitude coordinates.

```
-- Convert US National Grid point to SDO_GEMETRY point using SRID 4326  
-- (WGS 84, longitude/latitude).  
SELECT SDO_CS.FROM_USNG(  
    '18SUJ2348316806479498',  
    4326) FROM DUAL;  
  
WGS84(SDO_GTYPE, SDO_SRID, SDO_POINT(X, Y, Z), SDO_ELEM_INFO, SDO_ORDINATES)  
-----  
SDO_GEOMETRY(2001, 4326, SDO_POINT_TYPE(-77.03524, 38.8894673, NULL), NULL, NULL)
```

SDO_CS.GET_EPSG_DATA_VERSION

Format

SDO_CS.GET_EPSG_DATA_VERSION() RETURN VARCHAR2;

Description

Gets the version number of the EPSG dataset used by Spatial.

Parameters

None.

Usage Notes

The EPSG dataset is available from the European Petroleum Survey Group, and is distributed in a Microsoft Access 97 database and as SQL scripts.

Examples

The following example gets the version number of the EPSG dataset used by Spatial.

```
SELECT SDO_CS.GET_EPSG_DATA_VERSION FROM DUAL;
```

```
GET_EPSG_DATA_VERSION
```

```
-----6.  
5
```

SDO_CS.MAKE_2D

Format

```
SDO_CS.MAKE_2D(  
    geom3d    IN SDO_GEOMETRY,  
    target_srid IN NUMBER DEFAULT NULL) RETURN SDO_GEOMETRY;
```

Description

Converts a three-dimensional geometry into a two-dimensional geometry.

Parameters

geom3d

Three-dimensional geometry object.

target_srid

The SRID of the target coordinate reference system. Must be null or a value in the SRID column of the SDO_COORD_REF_SYS table (described in [Section 6.7.9](#)).

Usage Notes

This function returns a two-dimensional geometry object that removes the third (height) dimension value from each vertex in the input geometry.

For information about three-dimensional coordinate reference system support, see [Section 6.5](#).

Examples

The following example converts a three-dimensional geometry to a two-dimensional geometry by removing all the third (height) dimension values. (It uses as its input geometry the output geometry from the example for the [SDO_CS.MAKE_3D](#) function.)

```
SELECT SDO_CS.MAKE_2D(SDO_GEOMETRY(3003, 8307, NULL,  
    SDO_ELEM_INFO_ARRAY(1, 1003, 1),  
    SDO_ORDINATE_ARRAY(1, 1, 10, 5, 1, 10, 5, 7, 10, 1, 7, 10, 1, 1, 10)))  
FROM DUAL;
```

```
SDO_CS.MAKE_2D(SDO_GEOMETRY(3003, 8307, NULL, SDO_ELEM_INFO_ARRAY(1, 1003, 1), SDO_ORD  
-----  
SDO_GEOMETRY(2003, 8307, NULL, SDO_ELEM_INFO_ARRAY(1, 1003, 1), SDO_ORDINATE_ARR  
AY(1, 1, 5, 1, 5, 7, 1, 7, 1, 1))
```

SDO_CS.MAKE_3D

Format

```
SDO_CS.MAKE_3D(
    geom2d    IN SDO_GEOMETRY,
    height    IN NUMBER DEFAULT 0,
    target_srid IN NUMBER DEFAULT NULL) RETURN SDO_GEOMETRY;
```

Description

Converts a two-dimensional geometry into a three-dimensional geometry.

Parameters

geom2d

Two-dimensional geometry object.

height

Height value to be used in the third dimension for all vertices in the returned geometry. If this parameter is null or not specified, a height of 0 (zero) is used for all vertices.

target_srid

The SRID of the target coordinate reference system. Must be null or a value in the SRID column of the SDO_COORD_REF_SYS table (described in [Section 6.7.9](#)).

Usage Notes

For information about using this function to simulate a cross-dimensionality transformation, see [Section 6.5.4](#).

For information about three-dimensional coordinate reference system support, see [Section 6.5](#).

Examples

The following example converts the `cola_a` two-dimensional geometry to a three-dimensional geometry. (This example uses the definitions from the example in [Section 6.13](#)).

```
SELECT SDO_CS.MAKE_3D(c.shape, 10, 8307) FROM cola_markets_cs c
       WHERE c.name = 'cola_a';
```

```
SDO_CS.MAKE_3D(C.SHAPE,10,8307)(SDO_GTYPE, SDO_SRID, SDO_POINT(X, Y, Z), SDO_ELE
-----
SDO_GEOMETRY(3003, 8307, NULL, SDO_ELEM_INFO_ARRAY(1, 1003, 1), SDO_ORDINATE_ARR
AY(1, 1, 10, 5, 1, 10, 5, 7, 10, 1, 7, 10, 1, 1, 10))
```

SDO_CS.MAP_EPSG_SRID_TO_ORACLE

Format

```
SDO_CS.MAP_EPSG_SRID_TO_ORACLE(  
    epsg_srid IN NUMBER) RETURN NUMBER;
```

Description

Returns the Oracle Spatial SRID value corresponding to the specified EPSG SRID value.

Parameters

epsg_srid

The SRID of the EPSG coordinate reference system, as indicated in the COORD_REF_SYS_CODE field in the EPSG Coordinate Reference System table.

Usage Notes

This function returns a value that matches a value in the SRID column of the SDO_COORD_REF_SYS table (see [Section 6.7.9](#)).

To return the EPSG SRID value corresponding to the specified Oracle Spatial SRID value, use the [SDO_CS.MAP_ORACLE_SRID_TO_EPSG](#) function.

Examples

The following example returns the Oracle Spatial SRID value corresponding to EPSG SRID 23038.

```
SELECT SDO_CS.MAP_EPSG_SRID_TO_ORACLE(23038) FROM DUAL;
```

```
SDO_CS.MAP_EPSG_SRID_TO_ORACLE(23038)  
-----  
                                82361
```

SDO_CS.MAP_ORACLE_SRID_TO_EPSG

Format

```
SDO_CS.MAP_ORACLE_SRID_TO_EPSG(  
    legacy_srid IN NUMBER) RETURN NUMBER;
```

Description

Returns the EPSG SRID value corresponding to the specified Oracle Spatial SRID value.

Parameters

legacy_srid

Oracle Spatial SRID value. Must match a value in the LEGACY_CODE column of the SDO_COORD_REF_SYS table (see [Section 6.7.9](#)).

Usage Notes

This function returns the SRID of an EPSG coordinate reference system. The EPSG SRID value for a coordinate reference system is indicated in the COORD_REF_SYS_CODE field in the EPSG Coordinate Reference System table.

To return the Oracle Spatial SRID value corresponding to a specified EPSG SRID value, use the [SDO_CS.MAP_EPSG_SRID_TO_ORACLE](#) function.

Examples

The following example returns the EPSG SRID value corresponding to Oracle Spatial SRID 82361.

```
SELECT SDO_CS.MAP_ORACLE_SRID_TO_EPSG(82361) FROM DUAL;
```

```
SDO_CS.MAP_ORACLE_SRID_TO_EPSG(82361)  
-----  
                                23038
```

SDO_CS.REVOKE_PREFERENCE_FOR_OP

Format

```
SDO_CS.REVOKE_PREFERENCE_FOR_OP(  
    op_id      IN NUMBER,  
    source_crs IN NUMBER DEFAULT NULL,  
    target_crs IN NUMBER DEFAULT NULL,  
    use_case   IN VARCHAR2 DEFAULT NULL);
```

Description

Revokes a preference for an operation between a source coordinate system and a target coordinate system.

Parameters

op_id

ID number of the operation. Must match an `op_id` value that was specified in a call to the [SDO_CS.ADD_PREFERENCE_FOR_OP](#) procedure.

source_crs

The SRID of the source coordinate reference system. Must match the `source_crs` value in a `source_crs`, `target_crs`, and `use_case` combination that was specified in a call to the [SDO_CS.ADD_PREFERENCE_FOR_OP](#) procedure.

target_crs

The SRID of the target coordinate reference system. Must match the `target_crs` value in a `source_crs`, `target_crs`, and `use_case` combination that was specified in a call to the [SDO_CS.ADD_PREFERENCE_FOR_OP](#) procedure.

use_case

Name of the use case associated with the preference. Must match the `use_case` value in a `source_crs`, `target_crs`, and `use_case` combination that was specified in a call to the [SDO_CS.ADD_PREFERENCE_FOR_OP](#) procedure.

Usage Notes

This procedure reverses the effect of the [SDO_CS.ADD_PREFERENCE_FOR_OP](#) procedure.

If `use_case` is null, this procedure deletes one or more rows from the `SDO_PREFERRED_OPS_SYSTEM` table (described in [Section 6.7.24](#)). If `use_case` is not null, this procedure deletes one or more rows from the `SDO_PREFERRED_OPS_USER` table (described in [Section 6.7.25](#)).

Examples

The following example revokes a preference for operation ID 19777 to be used in transformations from SRID 4301 to SRID 4326 when use case `use_case_B` is specified for the transformation.

```
EXECUTE SDO_CS.REVOKE_PREFERENCE_FOR_OP(19777, 4301, 4326, 'use_case_B');
```

SDO_CS.TO_OGC_SIMPLEFEATURE_SRS

Format

```
SDO_CS.TO_OGC_SIMPLEFEATURE_SRS(
    wkt IN VARCHAR2) RETURN VARCHAR2;
```

Description

Converts a well-known text string from the Open Geospatial Consortium simple feature format that includes the TOWGS84 keyword to the format without the TOWGS84 keyword.

Parameters

wkt
Well-known text string.

Usage Notes

To convert a well-known text string from the Open Geospatial Consortium simple feature format without the TOWGS84 keyword to the format that includes the TOWGS84 keyword, use the [SDO_CS.FROM_OGC_SIMPLEFEATURE_SRS](#) procedure.

Examples

The following example converts a well-known text string from the Open Geospatial Consortium simple feature format that includes the TOWGS84 keyword to the format without the TOWGS84 keyword.

```
SELECT sdo_cs.to_ogc_simplefeature_srs('GEOGCS [ "Longitude / Latitude (DHDN)",
    DATUM [ "", SPHEROID ["Bessel 1841", 6377397.155, 299.1528128],
    TOWGS84 [582.000000, 105.000000, 414.000000, -1.040000, -0.350000, 3.080000,
    8.300000] ],
    PRIMEM [ "Greenwich", 0.000000 ], UNIT ["Decimal Degree",
0.01745329251994330]')
FROM DUAL;
```

```
MDSYS.SDO_CS.TO_OGC_SIMPLEFEATURE_SRS('GEOGCS["LONGITUDE/LATITUDE (DHDN)", DATUM["
-----
GEOGCS [ "Longitude / Latitude (DHDN)", DATUM [ "", SPHEROID ["Bessel 1841", 6377
397.155, 299.1528128], 582.000000, 105.000000, 414.000000, -1.040000, -0.350000,
3.080000, 8.300000 ], PRIMEM [ "Greenwich", 0.000000 ], UNIT ["Decimal Degree",
0.01745329251994330] ]
```

SDO_CS.TO_USNG

Format

```
SDO_CS.TO_USNG(  
    geom          IN SDO_GEOMETRY,  
    accuracy_in_meters IN NUMBER,  
    datum        IN VARCHAR2 DEFAULT 'NAD83') RETURN VARCHAR2;
```

Description

Converts a spatial point geometry object to a point represented in U.S. National Grid format.

Parameters

geom

Point geometry whose representation is to be converted to a point represented in U.S. National Grid format. The input geometry must have a valid non-null SRID, that is, a value in the SRID column of the SDO_COORD_REF_SYS table (described in [Section 6.7.9](#)).

accuracy_in_meters

Accuracy of the point location in meters. Should be 1 raised to a negative or positive power of 10 (for example, 0.001, 0.01, 0.1, 1, 10, 100, or 1000). Any other specified values are adjusted internally by Spatial, and the result might not be what you expect.

datum

The name of the datum on which the U.S. National Grid coordinate for the point is to be based. Must be either NAD83 or NAD27. The default value is NAD83.

Usage Notes

For information about Oracle Spatial support for the U.S. National Grid, see [Section 6.11](#).

The `accuracy_in_meters` value affects the number of digits used to represent the accuracy in the returned U.S. National Grid string. For example, if you specify 0.000001, the string will contain many digits; however, depending on the source of the data, the digits might not accurately reflect geographical reality. Consider the following scenarios. If you create a U.S. National Grid string from a UTM geometry, you can get perfect accuracy, because no inherently inaccurate transformation is involved. However, transforming from a Lambert projection to the U.S. National Grid format involves an inverse Lambert projection and a forward UTM projection, each of which has some inherent inaccuracy. If you request the resulting U.S. National Grid string with 1 millimeter (0.001) accuracy, the string will contain all the digits, but the millimeter-level digit will probably be geographically inaccurate.

To convert a point represented in U.S. National Grid format to a spatial point geometry, use the [SDO_CS.FROM_USNG](#) function.

Examples

The following example converts a spatial geometry point object with longitude/latitude coordinates to a point represented in U.S. National Grid format using an accuracy of 0.001 meter (1 millimeter).

```
-- Convert longitude/latitude (WGS 84) point to US National Grid.
SELECT SDO_CS.TO_USNG(
  SDO_GEOMETRY(2001, 4326,
    SDO_POINT_TYPE(-77.0352402158258, 38.8894673086544, NULL),
    NULL, NULL),
  0.001) FROM DUAL;

SDO_CS.TO_USNG(SDO_GEOMETRY(2001,4326,SDO_POINT_TYPE(-77.0352402158258,38.889467
-----
18SUJ2348316806479498
```

SDO_CS.TRANSFORM

Format

```
SDO_CS.TRANSFORM(  
    geom IN SDO_GEOMETRY,  
    to_srid IN NUMBER  
    ) RETURN SDO_GEOMETRY;  
  
or  
  
SDO_CS.TRANSFORM(  
    geom IN SDO_GEOMETRY,  
    to_sname IN VARCHAR2  
    ) RETURN SDO_GEOMETRY;  
  
or  
  
SDO_CS.TRANSFORM(  
    geom IN SDO_GEOMETRY,  
    use_case IN VARCHAR2,  
    to_srid IN NUMBER  
    ) RETURN SDO_GEOMETRY;  
  
or  
  
SDO_CS.TRANSFORM(  
    geom IN SDO_GEOMETRY,  
    use_plan IN TFM_PLAN  
    ) RETURN SDO_GEOMETRY;
```

Description

Transforms a geometry representation using a coordinate system (specified by SRID or name).

You can also associate a use case or a transformation plan with the transformation.

Parameters

geom

Geometry whose representation is to be transformed using another coordinate system. The input geometry must have a valid non-null SRID, that is, a value in the SRID column of the SDO_COORD_REF_SYS table (described in [Section 6.7.9](#)).

to_srid

The SRID of the coordinate system to be used for the transformation. It must be a value in the SRID column of the SDO_COORD_REF_SYS table (described in [Section 6.7.9](#)).

to_sname

The name of the coordinate system to be used for the transformation. It must be a value (specified exactly) in the COORD_REF_SYS_NAME column of the SDO_COORD_REF_SYS table (described in [Section 6.7.9](#)).

use_case

The name of the use case to be associated with the transformation. If you specify the string USE_SPHERICAL, the transformation uses spherical math instead of ellipsoidal math, thereby accommodating Google Maps and some other third-party tools that use projections based on spherical math. Use cases are explained in [Section 6.4](#). For considerations related to Google Maps, see [Section 6.12](#).

use_plan

Transformation plan. The TFM_PLAN object type is explained in [Section 6.6](#).

Usage Notes

Transformation can be done only between two different georeferenced coordinate systems or between two different local coordinate systems.

Transformation of circles and arcs is not supported, regardless of the type of coordinate systems involved.

An exception is raised if geom, to_srid, or to_sname is invalid. For geom to be valid for this function, its definition must include an SRID value matching a value in the SRID column of the SDO_COORD_REF_SYS table (described in [Section 6.7.9](#)).

Examples

The following example transforms the cola_c geometry to a representation that uses SRID value 8199. (This example uses the definitions from the example in [Section 6.13](#).)

```
-- Return the transformation of cola_c using to_srid 8199
-- ('Longitude / Latitude (Arc 1950)')
SELECT c.name, SDO_CS.TRANSFORM(c.shape, 8199)
       FROM cola_markets_cs c WHERE c.name = 'cola_c';
```

NAME

```
-----
SDO_CS.TRANSFORM(C.SHAPE,8199)(SDO_GTYPE, SDO_SRID, SDO_POINT(X, Y, Z), SDO_ELEM
```

cola_c

```
SDO_GEOMETRY(2003, 8199, NULL, SDO_ELEM_INFO_ARRAY(1, 1003, 1), SDO_ORDINATE_ARRAY(3.00074114, 3.00291482, 6.00067068, 3.00291287, 6.0006723, 5.00307625, 4.00071961, 5.00307838, 3.00074114, 3.00291482))
```

```
-- Same as preceding, but using to_sname parameter.
```

```
SELECT c.name, SDO_CS.TRANSFORM(c.shape, 'Longitude / Latitude (Arc 1950)')
       FROM cola_markets_cs c WHERE c.name = 'cola_c';
```

NAME

```
-----
SDO_CS.TRANSFORM(C.SHAPE,'LONGITUDE/LATITUDE(ARC1950)')(SDO_GTYPE, SDO_SRID, SDO
```

cola_c

```
SDO_GEOMETRY(2003, 8199, NULL, SDO_ELEM_INFO_ARRAY(1, 1003, 1), SDO_ORDINATE_ARRAY(3.00074114, 3.00291482, 6.00067068, 3.00291287, 6.0006723, 5.00307625, 4.00071961, 5.00307838, 3.00074114, 3.00291482))
```

SDO_CS.TRANSFORM_LAYER

Format

```
SDO_CS.TRANSFORM_LAYER(  
    table_in   IN VARCHAR2,  
    column_in  IN VARCHAR2,  
    table_out  IN VARCHAR2,  
    to_srid    IN NUMBER);
```

or

```
SDO_CS.TRANSFORM_LAYER(  
    table_in   IN VARCHAR2,  
    column_in  IN VARCHAR2,  
    table_out  IN VARCHAR2,  
    use_plan   IN TFM_PLAN);
```

or

```
SDO_CS.TRANSFORM_LAYER(  
    table_in   IN VARCHAR2,  
    column_in  IN VARCHAR2,  
    table_out  IN VARCHAR2,  
    use_case   IN VARCHAR2,  
    to_srid    IN NUMBER);
```

Description

Transforms an entire layer of geometries (that is, all geometries in a specified column in a table).

Parameters

table_in

Table containing the layer (`column_in`) whose geometries are to be transformed.

column_in

Column in `table_in` that contains the geometries to be transformed.

table_out

Table that will be created and that will contain the results of the transformation. See the Usage Notes for information about the format of this table.

to_srid

The SRID of the coordinate system to be used for the transformation. `to_srid` must be a value in the SRID column of the `SDO_COORD_REF_SYS` table (described in [Section 6.7.9](#)).

use_plan

Transformation plan. The TFM_PLAN object type is explained in [Section 6.6](#).

use_case

Name of the use case whose transformation rules are to be applied in performing the transformation. Use cases are explained in [Section 6.4](#).

Usage Notes

Transformation can be done only between two different georeferenced coordinate systems or between two different local coordinate systems.

An exception is raised if any of the following occurs:

- `table_in` does not exist, or `column_in` does not exist in the table.
- The geometries in `column_in` have a null or invalid SDO_SRID value.
- `table_out` already exists.
- `to_srid` is invalid.

The `table_out` table is created by the procedure and is filled with one row for each transformed geometry. This table has the columns shown in [Table 21–2](#).

Table 21–2 Table to Hold Transformed Layer

Column Name	Data Type	Description
SDO_ROWID	ROWID	Oracle ROWID (row address identifier). For more information about the ROWID data type, see <i>Oracle Database SQL Language Reference</i> .
GEOMETRY	SDO_GEOMETRY	Geometry object with coordinate values in the specified (<code>to_srid</code> parameter) coordinate system.

Examples

The following example transforms the geometries in the `shape` column in the `COLA_MARKETS_CS` table to a representation that uses SRID value 8199. The transformed geometries are stored in the newly created table named `COLA_MARKETS_CS_8199`. (This example uses the definitions from the example in [Section 6.13](#).)

```
-- Transform the entire SHAPE layer and put results in the table
-- named cola_markets_cs_8199, which the procedure will create.
CALL SDO_CS.TRANSFORM_LAYER('COLA_MARKETS_CS','SHAPE','COLA_MARKETS_CS_8199',8199);
```

[Example 6–18](#) in [Section 6.13](#) includes a display of the geometry object coordinates in both tables (`COLA_MARKETS_CS` and `COLA_MARKETS_CS_8199`).

SDO_CS.UPDATE_WKTS_FOR_ALL_EPSG_CRS

Format

```
SDO_CS.UPDATE_WKTS_FOR_ALL_EPSG_CRS();
```

Description

Updates the well-known text (WKT) description for all EPSG coordinate reference systems.

Parameters

None.

Usage Notes

For information about using procedures to update well-known text (WKT) description, see [Section 6.8.1.3](#).

Examples

The following example updates the WKT description for all EPSG coordinate reference systems.

```
EXECUTE SDO_CS.UPDATE_WKTS_FOR_ALL_EPSG_CRS;  
Updating SRID 4001...  
Updating SRID 4002...  
Updating SRID 4003...  
...  
Updating SRID 69036405...  
Updating SRID 69046405...
```

SDO_CS.UPDATE_WKTS_FOR_EPSG_CRS

Format

```
SDO_CS.UPDATE_WKTS_FOR_EPSG_CRS(  
    srid IN NUMBER);
```

Description

Updates the well-known text (WKT) description for the EPSG coordinate reference system associated with a specified SRID.

Parameters

srid

The SRID of the coordinate system whose well-known text (WKT) description is to be updated. An entry for the specified value must exist in the SDO_COORD_REF_SYS table (described in [Section 6.7.9](#)).

Usage Notes

This procedure updates the WKT descriptions for the specified SRID and all dependent SRIDs. For example, for SRID 4326 (WGS84 geodetic system), all EPSG coordinate systems that use this geodetic system will also be updated.

For information about using procedures to update well-known text (WKT) descriptions, see [Section 6.8.1.3](#).

Examples

The following example updates the WKT description for the EPSG coordinate reference system associated with SRID 4326.

```
EXECUTE SDO_CS.UPDATE_WKTS_FOR_EPSG_CRS(4326);
```

SDO_CS.UPDATE_WKTS_FOR_EPSG_DATUM

Format

```
SDO_CS.UPDATE_WKTS_FOR_EPSG_DATUM(  
    datum_id IN NUMBER);
```

Description

Updates the well-known text (WKT) description for all EPSG coordinate reference systems associated with a specified datum.

Parameters

datum_id

The ID of the datum. Must match a value in the DATUM_ID column of the SDO_DATUMS table (described in [Section 6.7.22](#)).

Usage Notes

For information about using procedures to update well-known text (WKT) description, see [Section 6.8.1.3](#).

Examples

The following example updates the WKT description for all EPSG coordinate reference systems associated with datum 5100.

```
EXECUTE SDO_CS.UPDATE_WKTS_FOR_EPSG_DATUM(5100);  
Updating SRID 5714...  
Updating SRID 5715...
```

SDO_CS.UPDATE_WKTS_FOR_EPSG_ELLIPS

Format

```
SDO_CS.UPDATE_WKTS_FOR_EPSG_ELLIPS(  
    ellipsoid_id IN NUMBER);
```

Description

Updates the well-known text (WKT) description for all EPSG coordinate reference systems associated with a specified ellipsoid.

Parameters

ellipsoid_id

The ID of the ellipsoid. Must match a value in the ELLIPSOID_ID column of the SDO_ELLIPSOIDS table (described in [Section 6.7.23](#)).

Usage Notes

For information about using procedures to update well-known text (WKT) description, see [Section 6.8.1.3](#).

Examples

The following example updates the WKT description for all EPSG coordinate reference systems associated with ellipsoid 7100.

```
EXECUTE SDO_CS.UPDATE_WKTS_FOR_EPSG_ELLIPS(7001);  
Updating SRID 4001...  
Updating SRID 4188...  
Updating SRID 29901...  
Updating SRID 61886405...  
Updating SRID 4277...  
Updating SRID 27700...  
Updating SRID 62776405...  
Updating SRID 4278...  
Updating SRID 62786405...  
Updating SRID 4279...  
Updating SRID 62796405...
```

SDO_CS.UPDATE_WKTS_FOR_EPSG_OP

Format

```
SDO_CS.UPDATE_WKTS_FOR_EPSG_OP(  
    coord_op_id IN NUMBER);
```

Description

Updates the well-known text (WKT) description for all EPSG coordinate reference systems associated with a specified coordinate transformation operation.

Parameters

coord_op_id

The ID of the SRID of the coordinate transformation operation. Must match a value in the COORD_OP_ID column of the SDO_COORD_OP_PARAM_VALS table (described in [Section 6.7.5](#)).

Usage Notes

For information about using procedures to update well-known text (WKT) description, see [Section 6.8.1.3](#).

Examples

The following example updates the WKT description for all EPSG coordinate reference systems associated with coordinate transformation operation 2000067.

```
EXECUTE SDO_CS.UPDATE_WKTS_FOR_EPSG_OP(2000067);  
Updating SRID 20000671...
```

SDO_CS.UPDATE_WKTS_FOR_EPSG_PARAM

Format

```
SDO_CS.UPDATE_WKTS_FOR_EPSG_PARAM(  
    coord_op_id IN NUMBER,  
    parameter_id IN NUMBER);
```

Description

Updates the well-known text (WKT) description for all EPSG coordinate reference systems associated with a specified coordinate transformation operation and parameter for transformation operations.

Parameters

coord_op_id

The ID of the SRID of the coordinate transformation operation. Must match a value in the COORD_OP_ID column of the SDO_COORD_OP_PARAM_VALS table (described in [Section 6.7.5](#)).

parameter_id

The ID of the SRID of the parameter for transformation operations. Must match a value in the PARAMETER_ID column of the SDO_COORD_OP_PARAM_VALS table (described in [Section 6.7.5](#)) where the COORD_OP_ID column value is equal to the coord_op_id parameter value.

Usage Notes

For information about using procedures to update well-known text (WKT) description, see [Section 6.8.1.3](#).

Examples

The following example updates the WKT description for all EPSG coordinate reference systems associated with coordinate transformation operation 9601 and parameter 8602.

```
EXECUTE SDO_CS.UPDATE_WKTS_FOR_EPSG_PARAM(9601, 8602);
```

SDO_CS.UPDATE_WKTS_FOR_EPSG_PM

Format

```
SDO_CS.UPDATE_WKTS_FOR_EPSG_PM(  
    prime_meridian_id IN NUMBER);
```

Description

Updates the well-known text (WKT) description for all EPSG coordinate reference systems associated with a specified prime meridian.

Parameters

prime_meridian_id

The ID of the prime meridian. Must match a value in the PRIME_MERIDIAN_ID column in the SDO_PRIME_MERIDIANS table (described in [Section 6.7.26](#)).

Usage Notes

For information about using procedures to update well-known text (WKT) description, see [Section 6.8.1.3](#).

Examples

The following example updates the WKT description for all EPSG coordinate reference systems associated with prime meridian 8902.

```
EXECUTE SDO_CS.UPDATE_WKTS_FOR_EPSG_PM(8902);  
Updating SRID 4803...  
Updating SRID 20790...  
Updating SRID 20791...  
Updating SRID 68036405...  
Updating SRID 4904...  
Updating SRID 2963...  
Updating SRID 69046405...
```

SDO_CS.VALIDATE_WKT

Format

```
SDO_CS.VALIDATE_WKT(
    srid IN NUMBER
) RETURN VARCHAR2;
```

Description

Validates the well-known text (WKT) description associated with a specified SRID.

Parameters

srid

The SRID of the coordinate system whose well-known text (WKT) description is to be validated. An entry for the specified value must exist in the SDO_COORD_REF_SYS table (described in [Section 6.7.9](#)).

Usage Notes

This function returns the string 'TRUE' if the WKT description is valid. If the WKT description is invalid, this function returns a string in the format 'FALSE (<position-number>)', where <position-number> is the number of the character position in the WKT description where the first error occurs.

The WKT description is checked to see if it satisfies the requirements described in [Section 6.8.1.1](#).

Examples

The following example validates the WKT description of the coordinate system associated with SRID 81989000. The results show that the cause of the invalidity (or the first cause of the invalidity) starts at character position 181 in the WKT description. (SRID 81989000 is not associated with any established coordinate system. Rather, it is for a deliberately invalid coordinate system that was inserted into a test version of the MDSYS.CS_SRS table, and it is not included in the MDSYS.CS_SRS table that is shipped with Oracle Spatial.)

```
SELECT SDO_CS.VALIDATE_WKT(81989000) FROM DUAL;
```

```
SDO_CS.VALIDATE_WKT(81989000)
```

```
-----
FALSE (181)
```

SDO_CSW_PROCESS Package (CSW Processing)

The MDSYS.SDO_CSW_PROCESS package contains subprograms for various processing operations related to support for Catalog Services for the Web (CSW).

To use the subprograms in this chapter, you must understand the conceptual and usage information about Catalog Services for the Web in [Chapter 16](#).

[Table 22-1](#) lists the CSW processing subprograms.

Table 22-1 Subprograms for CSW Processing Operations

Subprogram	Description
SDO_CSW_PROCESS.DeleteCapabilitiesInfo	Deletes the capabilities information that had been set by the SDO_CSW_PROCESS.InsertCapabilitiesInfo procedure.
SDO_CSW_PROCESS.DeleteDomainInfo	Deletes domain information related to a record type.
SDO_CSW_PROCESS.DeletePluginMap	Unregisters a plugin for processing and extracting spatial content for a record type.
SDO_CSW_PROCESS.DeleteRecordViewMap	Deletes information related to record view transformation.
SDO_CSW_PROCESS.GetRecordTypeId	Gets the record type ID for a type (specified by namespace and type name).
SDO_CSW_PROCESS.InsertCapabilitiesInfo	Inserts the capabilities template information.
SDO_CSW_PROCESS.InsertDomainInfo	Inserts domain information related to a record type.
SDO_CSW_PROCESS.InsertPluginMap	Registers a plugin for processing and extracting spatial content for a record type.
SDO_CSW_PROCESS.InsertRecordViewMap	Inserts information related to record view transformation.
SDO_CSW_PROCESS.InsertRtDataUpdated	Inserts a notification that the data for a record type was updated in the database.
SDO_CSW_PROCESS.InsertRtMDUpdated	Inserts a notification that the metadata for a record type was updated in the database.

The rest of this chapter provides reference information on the subprograms, listed in alphabetical order.

SDO_CSW_PROCESS.DeleteCapabilitiesInfo

Format

```
SDO_CSW_PROCESS.DeleteCapabilitiesInfo();
```

Description

Deletes the capabilities information that had been set by the [SDO_CSW_PROCESS.InsertCapabilitiesInfo](#) procedure.

Parameters

None.

Usage Notes

For information about support for Catalog Services for the Web, see [Chapter 16](#).

Examples

The following example deletes the capabilities information that had been set by the [SDO_CSW_PROCESS.InsertCapabilitiesInfo](#) procedure.

```
BEGIN
  SDO_CSW_PROCESS.DeleteCapabilitiesInfo;
END;
/
```

SDO_CSW_PROCESS.DeleteDomainInfo

Format

```
SDO_CSW_PROCESS.DeleteDomainInfo(  
    recordTypeId IN NUMBER,  
    propertyName IN VARCHAR2,  
    parameterName IN VARCHAR2);
```

Description

Deletes domain information related to a record type.

Parameters

recordTypeId

ID of the record type.

propertyName

Name of the property.

parameterName

Name of domain parameter to be deleted.

Usage Notes

For information about support for Catalog Services for the Web, see [Chapter 16](#).

Examples

The following example deletes domain information about the `resultType` parameter for a specified record type.

```
DECLARE  
    rtId NUMBER;  
BEGIN  
    rtId :=  
        sdo_csw_process.getRecordTypeId('http://www.opengis.net/cat/csw', 'Record');  
    sdo_csw_process.deleteDomainInfo(rtId, null, 'GetRecords.resultType');  
END;  
/
```

SDO_CSW_PROCESS.DeletePluginMap

Format

```
SDO_CSW_PROCESS.DeletePluginMap(  
    rtnsUrl IN VARCHAR2,  
    rtName IN VARCHAR2);
```

Description

Unregisters a plugin for processing and extracting non-GML spatial content for a record type.

Parameters

rtnsUrl

Uniform resource locator of namespace of the record type.

rtName

Name of the record type.

Usage Notes

To register a plugin, which is a user-defined implementation of the `extractSDO` function, use the [SDO_CSW_PROCESS.InsertPluginMap](#) procedure.

For information about creating and using the `extractSDO` function, see [Section 16.2.2](#).

For information about support for Catalog Services for the Web, see [Chapter 16](#).

Examples

The following example unregisters a plugin.

```
BEGIN  
    SDO_CSW_PROCESS.deletePluginMap('http://www.opengis.net/cat/csw',  
    'Record');  
END;  
/
```

SDO_CSW_PROCESS.DeleteRecordViewMap

Format

```
SDO_CSW_PROCESS.DeleteRecordViewMap(  
    recordTypeNs IN VARCHAR2,  
    viewSrcName  IN VARCHAR2,  
    targetTypeNs IN VARCHAR2);
```

Description

Deletes information related to record view transformation.

Parameters

recordTypeNs

URL of the namespace of the record type.

viewSrcName

Name of the source record type (for example, *BriefRecord*, *DCMIRecord*, *Record*, or *SummaryRecord*).

targetTypeName

Name of the destination record type (for example, *BriefRecord*, *DCMIRecord*, *Record*, or *SummaryRecord*).

Usage Notes

For information about support for Catalog Services for the Web, see [Chapter 16](#).

Examples

The following example deletes information related to record view transformation from source record type *BriefRecord* and destination record type *Record*.

```
BEGIN  
    SDO_CSW_PROCESS.deleteRecordViewMap('http://www.opengis.net/cat/csw',  
        'BriefRecord',  
        'Record');  
END;  
/
```

SDO_CSW_PROCESS.GetRecordTypeId

Format

```
SDO_CSW_PROCESS.GetRecordTypeId(  
    rtnsUrl IN VARCHAR2,  
    rtName IN VARCHAR2) RETURN NUMBER;
```

Description

Gets the record type ID for a type (specified by namespace and type name).

Parameters

rtnsUrl

Uniform resource locator (URL) of the namespace of the record type.

rtName

Name of the record type.

Usage Notes

For information about support for Catalog Services for the Web, see [Chapter 16](#).

Examples

The following example gets the record type ID of a record type named Record.

```
DECLARE  
    rtId NUMBER;  
BEGIN  
    rtId := SDO_CSW_PROCESS.getRecordTypeId('http://www.opengis.net/cat/csw',  
        'Record');  
END;  
/
```

SDO_CSW_PROCESS.InsertCapabilitiesInfo

Format

```
SDO_CSW_PROCESS.InsertCapabilitiesInfo(  
    capabilitiesInfo IN XMLTYPE);
```

Description

Inserts the capabilities template information.

Parameters

capabilitiesInfo

XML document for the capabilities template, which is used at runtime to generate capabilities documents.

Usage Notes

At runtime, the capabilities document is dynamically generated by binding feature type information from the CSW metadata with the capabilities template. For information about capabilities documents, see [Section 16.2.1](#).

For information about support for Catalog Services for the Web, see [Chapter 16](#).

Examples

The following example inserts the capabilities template information.

```
BEGIN  
    SDO_CSW_PROCESS.insertCapabilitiesInfo(  
        xmltype(bfilename('CSWUSERDIR', 'cswloadcapabilities.xml'),  
            nls_charset_id('AL32UTF8')));  
END;  
/
```

SDO_CSW_PROCESS.InsertDomainInfo

Format

```
SDO_CSW_PROCESS.InsertDomainInfo(  
    recordTypeId IN NUMBER,  
    propertyName IN VARCHAR2,  
    parameterName IN VARCHAR2,  
    pValue       IN MDSYS.STRINGLIST);
```

Description

Inserts domain information related to a record type.

Parameters

recordTypeId

ID of the record type

propertyName

Name of a domain property.

parameterName

Name of a domain parameter

pValue

An array of strings containing parameter values for `parameterName`. The `MDSYS.STRINGLIST` type is defined as `VARRAY(1000000) OF VARCHAR2(4000)`.

Usage Notes

For information about support for Catalog Services for the Web, see [Chapter 16](#).

Examples

The following example inserts domain information for the record type named Record.

```
DECLARE  
    rtId NUMBER;  
BEGIN  
    rtId := SDO_CSW_PROCESS.getRecordTypeId(  
        'http://www.opengis.net/cat/csw', 'Record');  
    SDO_CSW_PROCESS.insertDomainInfo(rtId,  
        null,  
        'GetRecords.resultType',  
        MDSYS.STRINGLIST('hits', 'results', 'validate'));  
END;  
/
```

SDO_CSW_PROCESS.InsertPluginMap

Format

```
SDO_CSW_PROCESS.InsertPluginMap(  
    rtnsUrl          IN VARCHAR2,  
    rtName           IN VARCHAR2,  
    pluginPackageName IN VARCHAR2);
```

Description

Registers a plugin for processing and extracting non-GML spatial content for a record type.

Parameters

rtnsUrl

Uniform resource locator of the namespace of the record type.

rtName

Name of the record type.

pluginPackageName

Name of the PL/SQL package object for the plugin.

Usage Notes

The plugin must contain the user-defined implementation of the `extractSDO` function. A plugin is needed if the records are not in GML format. For detailed information about creating and using the `extractSDO` function, see [Section 16.2.2](#).

You must grant EXECUTE access on the plugin package (`pluginPackageName` parameter) to user MDSYS and to the CSW administrative user.

For information about support for Catalog Services for the Web, see [Chapter 16](#).

Examples

The following example registers a plugin.

```
BEGIN  
    SDO_CSW_PROCESS.insertPluginMap('http://www.opengis.net/cat/csw',  
        'Record', 'csw_admin_usr.csw_RT_1_package');  
END;  
/
```

SDO_CSW_PROCESS.InsertRecordViewMap

Format

```
SDO_CSW_PROCESS.InsertRecordViewMap(  
    recordTypeNs IN VARCHAR2,  
    viewSrcName  IN VARCHAR2,  
    targetTypeNs IN VARCHAR2,  
    mapInfo      IN XMLTYPE,  
    mapType      IN VARCHAR2);
```

Description

Inserts information related to record view transformation.

Parameters

recordTypeNs

URL of the namespace of the record type.

viewSrcName

Name of the source record type (for example, *BriefRecord*, *DCMIRecord*, *Record*, or *SummaryRecord*).

targetTypeNs

Name of the destination of the record type (for example, *BriefRecord*, *DCMIRecord*, *Record*, or *SummaryRecord*).

mapInfo

XSLT definition of the mapping. (See the comments in the example at the end of this section for a transformation from *BriefRecord* type to *Record* type.)

mapType

Map type (brief, summary, and so on)

Usage Notes

For information about support for Catalog Services for the Web, see [Chapter 16](#).

Examples

The following example inserts information related to transformation from *BriefRecord* type to *Record* type.

```
create or replace directory CSWUSERDIR as 'dir_path_where_mapinfo.xml_file_is_  
located' ;  
  
/*  
// Content of mapinfo.xml could be that which transforms  
// all <csw:BriefRecord> node to <csw:Record> node, where csw is  
// the namespace alias for "http://www.opengis.net/cat/csw"  
  
<?xml version="1.0" encoding="UTF-8"?>  
<xsl:stylesheet version="1.0" xmlns:xsl="http://www.w3.org/1999/XSL/Transform"  
xmlns:csw="http://www.opengis.net/cat/csw">
```

```

<xsl:output method="xml" version="1.0" encoding="UTF-8" indent="yes" />

<xsl:template match="/">
  <csw:Record xmlns:csw="http://www.opengis.net/cat/csw"
xmlns:dc="http://www.purl.org/dc/elements/1.1/"
xmlns:ows="http://www.opengis.net/ows" xmlns:dct="http://www.purl.org/dc/terms/">
    <xsl:apply-templates select="@*|node()" />
  </csw:Record>
</xsl:template>

<xsl:template match="csw:BriefRecord">
  <xsl:apply-templates select="@*|node()" />
</xsl:template>

<xsl:template match="@*|node()">
  <xsl:copy>
    <xsl:apply-templates select="@*|node()" />
  </xsl:copy>
</xsl:template>

</xsl:stylesheet>
*/

DECLARE
  rtId NUMBER;
BEGIN
  SDO_CSW_PROCESS.insertRecordViewMap('http://www.opengis.net/cat/csw',
    'BriefRecord',
    'Record',
    xmltype(bfilename('CSWUSERDIR', 'mapinfo.xml'), nls_charset_id('AL32UTF8')),
    'brief');
END;
/

```

SDO_CSW_PROCESS.InsertRtDataUpdated

Format

```
SDO_CSW_PROCESS.InsertRtDataUpdated(  
    ns          IN VARCHAR2,  
    name        IN VARCHAR2,  
    updatedRowList IN ROWPOINTERLIST,  
    updateTs     IN TIMESTAMP);
```

Description

Inserts a notification that the data for a record type was updated in the database.

Parameters

ns

Namespace of the record type.

name

Name of the record type.

updatedRowList

List of rowids of rows that have been updated.

updateTS

Timestamp value indicating when the data was updated.

Usage Notes

This procedure is used for CSW cache data synchronization. It queries the MDSYS.CSW_RECORD_TYPES\$ system table.

For information about support for Catalog Services for the Web, see [Chapter 16](#).

Examples

The following example inserts a notification for a specified record type that the data was updated for the rows associated with specific rowids.

```
BEGIN  
updatedRowIdList:= . . . -- list of rowIds that have been updated  
-- in the table referred to by the dataPointer column of the  
-- mdsys.CSW_Record_Types$ table for the row whose  
-- typeNameNS column value is 'http://www.opengis.net/cat/csw' and  
-- typeName column value is 'Record'  
. . .  
    SDO_CSW_PROCESS.insertRtDataUpdated('http://www.opengis.net/cat/csw',  
        'Record', updatedRowIdList, sysdate);  
. . .  
END;  
/
```

SDO_CSW_PROCESS.InsertRtMDUpdated

Format

```
SDO_CSW_PROCESS.InsertRtMDUpdated(  
    ns      IN VARCHAR2,  
    name    IN VARCHAR2,  
    updateTs IN TIMESTAMP);
```

Description

Inserts a notification that the metadata for a record type was updated in the database.

Parameters

ns

Namespace of the record type.

name

Name of the record type.

updateTS

Date and time when the metadata was updated.

Usage Notes

This procedure is used for WFS cache metadata synchronization.

For information about support for Catalog Services for the Web, see [Chapter 16](#).

Examples

The following example inserts a notification that the metadata for the Record record type was updated in the database.

```
BEGIN  
    SDO_CSW_PROCESS.insertRtMDUpdated('http://www.opengis.net/cat/csw',  
        'Record', sysdate);  
END;
```

SDO_GCDR Package (Geocoding)

The MDSYS.SDO_GCDR package contains subprograms for geocoding address data.

To use the subprograms in this chapter, you must understand the conceptual and usage information about geocoding in [Chapter 11](#).

[Table 23–1](#) lists the geocoding subprograms.

Table 23–1 Subprograms for Geocoding Address Data

Subprogram	Description
SDO_GCDR.CREATE_PROFILE_TABLES	Creates the CG_COUNTRY_PROFILE, GC_PARSER_PROFILES, and GC_PARSER_PROFILEAFS tables in the caller's schema.
SDO_GCDR.GEOCODE	Geocodes an unformatted address and returns an SDO_GEO_ADDR object.
SDO_GCDR.GEOCODE_ADDR	Geocodes an input address using attributes in an SDO_GEO_ADDR object, and returns the first matched address as an SDO_GEO_ADDR object.
SDO_GCDR.GEOCODE_ADDR_ALL	Geocodes an input address using attributes in an SDO_GEO_ADDR object, and returns matching addresses as an SDO_ADDR_ARRAY object.
SDO_GCDR.GEOCODE_ALL	Geocodes all addresses associated with an unformatted address and returns the result as an SDO_ADDR_ARRAY object.
SDO_GCDR.GEOCODE_AS_GEOMETRY	Geocodes an unformatted address and returns an SDO_GEOMETRY object.
SDO_GCDR.REVERSE_GEOCODE	Reverse geocodes a location, specified by its spatial geometry object and country, and returns an SDO_GEO_ADDR object.

The rest of this chapter provides reference information on the subprograms, listed in alphabetical order.

SDO_GCDR.CREATE_PROFILE_TABLES

Format

```
SDO_GCDR.CREATE_PROFILE_TABLES;
```

Description

Creates the CG_COUNTRY_PROFILE, GC_PARSER_PROFILES, and GC_PARSER_PROFILEAFS tables in the caller's schema.

Parameters

None.

Usage Notes

Use this procedure only if your geocoding data provider does not supply the GC_PARSER_PROFILES and GC_PARSER_PROFILEAFS tables. See [Section 11.6](#) for more information.

Examples

The following example creates the GC_PARSER_PROFILES and GC_PARSER_PROFILEAFS tables in the caller's schema.

```
EXECUTE SDO_GCDR.CREATE_PROFILE_TABLES;
```

SDO_GCDR.GEOCODE

Format

```
SDO_GCDR.GEOCODE(
    username    IN VARCHAR2,
    addr_lines  IN SDO_KEYWORDARRAY,
    country     IN VARCHAR2,
    match_mode  IN VARCHAR2
) RETURN SDO_GEO_ADDR;
```

Description

Geocodes an unformatted address and returns the result as an SDO_GEO_ADDR object.

Parameters

username

Name of the user that owns the tables containing the geocoding data.

addr_lines

An array of quoted strings representing the unformatted address to be geocoded. The SDO_KEYWORDARRAY type is described in [Section 11.2.3](#).

country

Country name or ISO country code.

match_mode

Match mode for the geocoding operation. Match modes are explained in [Section 11.1.2](#).

Usage Notes

This function returns an object of type SDO_GEO_ADDR, which is described in [Section 11.2.1](#). It performs the same operation as the [SDO_GCDR.GEOCODE_AS_GEOMETRY](#) function; however, that function returns an SDO_GEOMETRY object.

Examples

The following example geocodes the address of City Hall in San Francisco, California, using the RELAX_BASE_NAME match mode. It returns the longitude and latitude coordinates of this address as -122.41815 and 37.7784183, respectively.

```
SELECT SDO_GCDR.GEOCODE('SCOTT', SDO_KEYWORDARRAY('1 Carlton B Goodlett Pl',
    'San Francisco, CA 94102'), 'US', 'RELAX_BASE_NAME') FROM DUAL;
```

```
SDO_GCDR.GEOCODE('SCOTT', SDO_KEYWORDARRAY('1CARLTONBGOODLETTPL', 'SANFRANCISCO
```

```
-----
SDO_GEO_ADDR(0, SDO_KEYWORDARRAY(), NULL, 'CARLTON B GOODLETT PL', NULL, NULL, '
SAN FRANCISCO', NULL, 'CA', 'US', '94102', NULL, '94102', NULL, '1', 'CARLTON B
GOODLETT', 'PL', 'F', 'F', NULL, NULL, 'L', .01, 23614360, '???#ENUT?B281CP?',
1, 'RELAX_BASE_NAME', -122.41815, 37.7784183, '???0101010??000?')
```

SDO_GCDR.GEOCODE_ADDR

Format

```
SDO_GCDR.GEOCODE_ADDR(  
    gc_username IN VARCHAR2,  
    address     IN SDO_GEO_ADDR  
    ) RETURN SDO_GEO_ADDR;
```

Description

Geocodes an input address using attributes in an SDO_GEO_ADDR object, and returns the first matched address as an SDO_GEO_ADDR object.

Parameters

gc_username

Name of the user that owns the tables containing the geocoding data.

address

An SDO_GEO_ADDR object with one or more attributes set. The SDO_GEO_ADDR type is described in [Section 11.2.1](#).

Usage Notes

This function enables you to specify as many attributes in the input SDO_GEO_ADDR object as you can or want to set. It finds the first matching address, and returns an SDO_GEO_ADDR object with all possible attributes set.

Unlike the [SDO_GCDR.GEOCODE](#) function, which geocodes input addresses specified by unformatted address lines, the SDO_GCDR.GEOCODE_ADDR function input addresses specified by individual addressing fields defined in SDO_GEO_ADDR objects. When you use unformatted address lines, you rely on the geocoding software to parse the input address and decompose it into individual address fields. This process usually works well, but it can produce undesirable results if the input addresses are not well formatted. By contrast, when you specify parts of the input address as SDO_GEO_ADDR object attributes, you can reduce the chance of geocoding errors and produce more desirable results.

For examples of the SDO_GCDR.GEOCODE_ADDR function, see [Example 11–2](#) and [Example 11–3](#) in [Section 11.4](#).

See also the [SDO_GCDR.GEOCODE_ADDR_ALL](#) function, which performs the same operation as this function, but which can return more than one address.

Examples

The following example returns the geocoded result for a point of interest named CALIFORNIA PACIFIC MEDICAL CTR. The example uses a user-defined function named `create_addr_from_placename` (as defined in [Example 11–2](#) in [Section 11.4](#)) to construct the input SDO_GEO_ADDR object.

```
SELECT sdo_gcdr.geocode_addr('SCOTT',  
    create_addr_from_placename('CALIFORNIA PACIFIC MEDICAL CTR', 'US'))  
FROM DUAL;
```

```
SDO_GCDR.GEOCODE_ADDR('SCOTT',CREATE_ADDR_FROM_PLACENAME('CALIFORNIA PACIFIC ME
-----
SDO_GEO_ADDR(0, SDO_KEYWORDARRAY(), 'CALIFORNIA PACIFIC MEDICAL CTR-SF', 'BUCHAN
AN ST', NULL, NULL, 'SAN FRANCISCO', NULL, 'CA', 'US', '94115', NULL, '94115', N
ULL, '2333', NULL, NULL, 'F', 'F', NULL, NULL, 'L', 0, 23599031, '?????????B281
CP?', 4, 'DEFAULT', -122.43097, 37.79138, '???4141114??404?')
```

SDO_GCDR.GEOCODE_ADDR_ALL

Format

```
SDO_GCDR.GEOCODE_ADDR_ALL(
  gc_username IN VARCHAR2,
  address      IN SDO_GEO_ADDR,
  max_res_num IN NUMBER DEFAULT 4000
) RETURN SDO_ADDR_ARRAY;
```

Description

Geocodes an input address using attributes in an SDO_GEO_ADDR object, and returns matching addresses as an SDO_ADDR_ARRAY object (described in [Section 11.2.2](#)).

Parameters

gc_username

Name of the user that owns the tables containing the geocoding data.

address

An SDO_GEO_ADDR object with one or more attributes set. The SDO_GEO_ADDR type is described in [Section 11.2.1](#).

max_res_num

Maximum number of results to return in the SDO_ADDR_ARRAY object. The default value is 4000.

Usage Notes

This function enables you to specify as many attributes in the input SDO_GEO_ADDR object as you can or want to set. It finds matching addresses (up to 4000 or the limit specified in the max_res_num parameter), and returns an SDO_ADDR_ARRAY object in which each geocoded result has all possible attributes set.

This function performs the same operation as the [SDO_GCDR.GEOCODE_ADDR](#) function, except that it can return more than one address. See the Usage Notes for the [SDO_GCDR.GEOCODE_ADDR](#) function for more information.

Examples

The following example returns up to three geocoded results for a point of interest named CALIFORNIA PACIFIC MEDICAL CTR. (In this case only one result is returned, because the geocoding data contains only one address matching that point of interest.) The example uses a user-defined function named create_addr_from_placename (as defined in [Example 11-2](#) in [Section 11.4](#)) to construct the input SDO_GEO_ADDR object.

```
SELECT sdo_gcdr.geocode_addr_all('SCOTT',
  create_addr_from_placename('CALIFORNIA PACIFIC MEDICAL CTR', 'US'), 3)
FROM DUAL;

SDO_GCDR.GEOCODE_ADDR_ALL('SCOTT',CREATE_ADDR_FROM_PLACENAME('CALIFORNIAPACIF
-----
```

```
SDO_ADDR_ARRAY(SDO_GEO_ADDR(0, SDO_KEYWORDARRAY(), 'CALIFORNIA PACIFIC MEDICAL C  
TR-SF', 'BUCHANAN ST', NULL, NULL, 'SAN FRANCISCO', NULL, 'CA', 'US', '94115', N  
ULL, '94115', NULL, '2333', NULL, NULL, 'F', 'F', NULL, NULL, 'L', 0, 23599031,  
'?????????B281CP?', 4, 'DEFAULT', -122.43097, 37.79138, '????4141114??404?'))
```

SDO_GCDR.GEOCODE_ALL

Format

```
SDO_GCDR.GEOCODE_ALL(  
    gc_username IN VARCHAR2,  
    addr_lines   IN SDO_KEYWORDARRAY,  
    country      IN VARCHAR2,  
    match_mode   IN VARCHAR2  
    ) RETURN SDO_ADDR_ARRAY;
```

Description

Geocodes all addresses associated with an unformatted address and returns the result as an SDO_ADDR_ARRAY object.

Parameters

gc_username

Name of the user that owns the tables containing the geocoding data.

addr_lines

An array of quoted strings representing the unformatted address to be geocoded. The SDO_KEYWORDARRAY type is described in [Section 11.2.3](#).

country

Country name or ISO country code.

match_mode

Match mode for the geocoding operation. Match modes are explained in [Section 11.1.2](#).

Usage Notes

This function returns an object of type SDO_ADDR_ARRAY, which is described in [Section 11.2.2](#). It performs the same operation as the SDO_GCDR.GEOCODE function; however, it can return results for multiple addresses, in which case the returned SDO_ADDR_ARRAY object contains multiple SDO_GEO_ADDR objects. If your application needs to select one of the addresses for some further operations, you can use the information about each returned address to help you make that selection.

Each SDO_GEO_ADDR object in the returned SDO_ADDR_ARRAY array represents the center point of each street segment that matches the criteria in the addr_lines parameter. For example, if Main Street extends into two postal codes, or if there are two separate streets named Main Street in two separate postal codes, and if you specify Main Street and a city and state for this function, the returned SDO_ADDR_ARRAY array contains two SDO_GEO_ADDR objects, each reflecting the center point of Main Street in a particular postal code. The house or building number in each SDO_GEO_ADDR object is the house or building number located at the center point of the street segment, even if the input address contains no house or building number or a nonexistent number.

Examples

The following example returns an array of geocoded results, each result reflecting the center point of Clay Street in all postal codes in San Francisco, California, in which the street extends. The resulting array includes four SDO_GEO_ADDR objects, each reflecting the house at the center point of the Clay Street segment in each of the four postal codes (94108, 94115, 94118, and 94109) into which Clay Street extends.

```
SELECT SDO_GCDR.GEOCODE_ALL('SCOTT',
  SDO_KEYWORDARRAY('Clay St', 'San Francisco, CA'),
  'US', 'DEFAULT') FROM DUAL;

SDO_GCDR.GEOCODE_ALL('SCOTT',SDO_KEYWORDARRAY('CLAYST','SANFRANCISCO,CA'),'US
-----
SDO_ADDR_ARRAY(SDO_GEO_ADDR(1, SDO_KEYWORDARRAY(), NULL, 'CLAY ST', NULL, NULL,
'SAN FRANCISCO', NULL, 'CA', 'US', '94109', NULL, '94109', NULL, '1698', 'CLAY',
'ST', 'F', 'F', NULL, NULL, 'L', 0, 23600700, '????#ENUT?B281CP?', 1, 'DEFAULT'
, -122.42093, 37.79236, '????4101010??004?'), SDO_GEO_ADDR(1, SDO_KEYWORDARRAY()
, NULL, 'CLAY ST', NULL, NULL, 'SAN FRANCISCO', NULL, 'CA', 'US', '94111', NULL,
'94111', NULL, '398', 'CLAY', 'ST', 'F', 'F', NULL, NULL, 'L', 0, 23600678, '??
??#ENUT?B281CP?', 1, 'DEFAULT', -122.40027, 37.79499, '????4101010??004?'), SDO_
GEO_ADDR(1, SDO_KEYWORDARRAY(), NULL, 'CLAY ST', NULL, NULL, 'SAN FRANCISCO', NU
LL, 'CA', 'US', '94108', NULL, '94108', NULL, '978', 'CLAY', 'ST', 'F', 'F', NUL
L, NULL, 'L', 0, 23600689, '????#ENUT?B281CP?', 1, 'DEFAULT', -122.40904, 37.793
85, '????4101010??004?'), SDO_GEO_ADDR(1, SDO_KEYWORDARRAY(), NULL, 'CLAY ST', N
ULL, NULL, 'SAN FRANCISCO', NULL, 'CA', 'US', '94115', NULL, '94115', NULL, '279
8', 'CLAY', 'ST', 'F', 'F', NULL, NULL, 'L', 0, 23600709, '????#ENUT?B281CP?', 1
, 'DEFAULT', -122.43909, 37.79007, '????4101010??004?'), SDO_GEO_ADDR(1, SDO_KEY
WORDARRAY(), NULL, 'CLAY ST', NULL, NULL, 'SAN FRANCISCO', NULL, 'CA', 'US', '94
118', NULL, '94118', NULL, '3698', 'CLAY', 'ST', 'F', 'F', NULL, NULL, 'L', 0, 2
3600718, '????#ENUT?B281CP?', 1, 'DEFAULT', -122.45372, 37.78822, '????4101010??
004?'))
```

SDO_GCDR.GEOCODE_AS_GEOMETRY

Format

```
SDO_GCDR.GEOCODE_AS_GEOMETRY(  
    username    IN VARCHAR2,  
    addr_lines  IN SDO_KEYWORDARRAY,  
    country     IN VARCHAR2  
    ) RETURN SDO_GEOMETRY;
```

Description

Geocodes an unformatted address and returns the result as an SDO_GEOMETRY object.

Parameters

username

Name of the user that owns the tables containing the geocoding data.

addr_lines

An array of quoted strings representing the unformatted address to be geocoded. The SDO_KEYWORDARRAY type is described in [Section 11.2.3](#).

country

Country name or ISO country code.

Usage Notes

This function returns an object of type SDO_GEOMETRY. It performs the same operation as the [SDO_GCDR.GEOCODE](#) function; however, that function returns an SDO_GEOADDR object.

This function uses a match mode of 'DEFAULT' for the geocoding operation. Match modes are explained in [Section 11.1.2](#).

Examples

The following example geocodes the address of City Hall in San Francisco, California. It returns an SDO_GEOMETRY object in which the longitude and latitude coordinates of this address are -122.41815 and 37.7784183, respectively.

```
SELECT SDO_GCDR.GEOCODE_AS_GEOMETRY('SCOTT',  
    SDO_KEYWORDARRAY('1 Carlton B Goodlett Pl', 'San Francisco, CA 94102'),  
    'US') FROM DUAL;  
  
SDO_GCDR.GEOCODE_AS_GEOMETRY('SCOTT', SDO_KEYWORDARRAY('1CARLTONBGODLETTPL', '  
-----  
SDO_GEOMETRY(2001, 8307, SDO_POINT_TYPE(-122.41815, 37.7784183, NULL), NULL, NUL  
L)
```

SDO_GCDR.REVERSE_GEOCODE

Format

```
SDO_GCDR.REVERSE_GEOCODE(
    username IN VARCHAR2,
    location  IN SDO_GEOMETRY,
    country   IN VARCHAR2
) RETURN SDO_GEO_ADDR;
```

Description

Reverse geocodes a location, specified by its spatial geometry object and country, and returns the result as an SDO_GEO_ADDR object.

Parameters

username

Name of the user that owns the tables containing the geocoding data.

location

An SDO_GEOMETRY object that specifies the point location to be reverse geocoded.

country

Country name or ISO country code.

Usage Notes

This function returns an object of type SDO_GEO_ADDR, which is described in [Section 11.2.1](#).

A spatial index must be created on the table GC_ROAD_SEGMENT_<table-suffix>.

Examples

The following example reverse geocodes a point with the longitude and latitude values (-122.41815, 37.7784183). For this example, a spatial index was created on the GEOMETRY column in the GC_ROAD_SEGMENT_US table.

```
SELECT SDO_GCDR.REVERSE_GEOCODE('SCOTT',
    SDO_GEOMETRY(2001, 8307,
        SDO_POINT_TYPE(-122.41815, 37.7784183, NULL), NULL, NULL),
    'US') FROM DUAL;
```

```
SDO_GCDR.REVERSE_GEOCODE('SCOTT', SDO_GEOMETRY(2001, 8307, SDO_POINT_TYPE(-122.4
-----
SDO_GEO_ADDR(0, SDO_KEYWORDARRAY(), NULL, 'POLK ST', NULL, NULL, 'SAN FRANCISCO'
, NULL, 'CA', 'US', '94102', NULL, '94102', NULL, '200', 'POLK', 'ST', 'F', 'F',
NULL, NULL, 'R', .00966633, 23614360, '', 1, 'DEFAULT', -122.41815, 37.7784177,
'????4141414??404?')
```

SDO_GEOM Package (Geometry)

This chapter contains descriptions of the geometry-related PL/SQL subprograms in the SDO_GEOM package, which can be grouped into the following categories:

- Relationship (True/False) between two objects: RELATE, WITHIN_DISTANCE
- Validation: VALIDATE_GEOMETRY_WITH_CONTEXT, VALIDATE_LAYER_WITH_CONTEXT
- Single-object operations: SDO_ALPHA_SHAPE, SDO_ARC_DENSIFY, SDO_AREA, SDO_BUFFER, SDO_CENTROID, SDO_CONVEXHULL, SDO_CONCAVEHULL, SDO_CONCAVEHULL_BOUNDARY, SDO_LENGTH, SDO_MAX_MBR_ORDINATE, SDO_MIN_MBR_ORDINATE, SDO_MBR, SDO_POINTONSURFACE, SDO_TRIANGULATE, SDO_VOLUME
- Two-object operations: SDO_CLOSEST_POINTS, SDO_DISTANCE, SDO_DIFFERENCE, SDO_INTERSECTION, SDO_UNION, SDO_XOR

The geometry subprograms are listed [Table 24–1](#), and some usage information follows the table.

Table 24–1 *Geometry Subprograms*

Subprogram	Description
SDO_GEOM.RELATE	Determines how two objects interact.
SDO_GEOM.SDO_ALPHA_SHAPE	Returns the alpha shape geometry of the input geometry, based on a specified radius value.
SDO_GEOM.SDO_ARC_DENSIFY	Changes each circular arc into an approximation consisting of straight lines, and each circle into a polygon consisting of a series of straight lines that approximate the circle.
SDO_GEOM.SDO_AREA	Computes the area of a two-dimensional polygon.
SDO_GEOM.SDO_BUFFER	Generates a buffer polygon around or inside a geometry.
SDO_GEOM.SDO_CENTROID	Returns the centroid of a polygon.
SDO_GEOM.SDO_CLOSEST_POINTS	Computes the minimum distance between two geometries and the points (one on each geometry) that are the minimum distance apart.
SDO_GEOM.SDO_CONCAVEHULL	Returns a polygon-type object that represents the concave hull of a geometry object.
SDO_GEOM.SDO_CONCAVEHULL_BOUNDARY	Returns a polygon-type object that represents the concave hull of a geometry object, based on boundary points rather than the alpha shape.

Table 24–1 (Cont.) Geometry Subprograms

Subprogram	Description
SDO_GEOM.SDO_CONVEXHULL	Returns a polygon-type object that represents the convex hull of a geometry object.
SDO_GEOM.SDO_DIFFERENCE	Returns a geometry object that is the topological difference (MINUS operation) of two geometry objects.
SDO_GEOM.SDO_DISTANCE	Computes the distance between two geometry objects.
SDO_GEOM.SDO_INTERSECTION	Returns a geometry object that is the topological intersection (AND operation) of two geometry objects.
SDO_GEOM.SDO_LENGTH	Computes the length or perimeter of a geometry.
SDO_GEOM.SDO_MAX_MBR_ORDINATE	Returns the maximum value for the specified ordinate (dimension) of the minimum bounding rectangle of a geometry object.
SDO_GEOM.SDO_MBR	Returns the minimum bounding rectangle of a geometry.
SDO_GEOM.SDO_MIN_MBR_ORDINATE	Returns the minimum value for the specified ordinate (dimension) of the minimum bounding rectangle of a geometry object.
SDO_GEOM.SDO_POINTONSURFACE	Returns a point that is guaranteed to be on the surface of a polygon.
SDO_GEOM.SDO_TRIANGULATE	Returns a collection of triangles resulting from Delaunay triangulation of the input geometry.
SDO_GEOM.SDO_UNION	Returns a geometry object that is the topological union (OR operation) of two geometry objects.
SDO_GEOM.SDO_VOLUME	Computes the volume of a three-dimensional solid geometry.
SDO_GEOM.SDO_XOR	Returns a geometry object that is the topological symmetric difference (XOR operation) of two geometry objects.
SDO_GEOM.VALIDATE_GEOMETRY_WITH_CONTEXT	Determines if a geometry is valid, and returns context information if the geometry is invalid.
SDO_GEOM.VALIDATE_LAYER_WITH_CONTEXT	Determines if all geometries stored in a column are valid, and returns context information about any invalid geometries.
SDO_GEOM.WITHIN_DISTANCE	Determines if two geometries are within a specified distance from one another.

The following usage information applies to the geometry subprograms. (See also the Usage Notes under the reference information for each subprogram.)

- Certain combinations of input parameters and operations can return a null value, that is, an empty geometry. For example, requesting the intersection of two disjoint geometry objects returns a null value.
- A null value (empty geometry) as an input parameter to a geometry function (for example, [SDO_GEOM.RELATE](#)) produces an error.
- Certain operations can return a geometry of a different type than one or both input geometries. For example, the intersection of a line and an overlapping polygon

returns a line; the intersection of two lines returns a point; and the intersection of two tangent polygons returns a line.

- SDO_GEOM subprograms are supported for two-dimensional geometries only, except for the following, which are supported for both two-dimensional and three-dimensional geometries:
 - SDO_GEOM.RELATE with (A) the ANYINTERACT mask, or (B) the INSIDE mask (3D support for solid geometries only)
 - SDO_GEOM.SDO_AREA
 - SDO_GEOM.SDO_DISTANCE
 - SDO_GEOM.SDO_LENGTH
 - SDO_GEOM.SDO_MAX_MBR_ORDINATE
 - SDO_GEOM.SDO_MBR
 - SDO_GEOM.SDO_MIN_MBR_ORDINATE
 - SDO_GEOM.SDO_VOLUME
 - SDO_GEOM.VALIDATE_GEOMETRY_WITH_CONTEXT
 - SDO_GEOM.VALIDATE_LAYER_WITH_CONTEXT
 - SDO_GEOM.WITHIN_DISTANCE

SDO_GEOM.RELATE

Format

```
SDO_GEOM.RELATE(  
    geom1 IN SDO_GEOMETRY,  
    dim1  IN SDO_DIM_ARRAY,  
    mask  IN VARCHAR2,  
    geom2 IN SDO_GEOMETRY,  
    dim2  IN SDO_DIM_ARRAY  
    ) RETURN VARCHAR2;
```

or

```
SDO_GEOM.RELATE(  
    geom1 IN SDO_GEOMETRY,  
    mask  IN VARCHAR2,  
    geom2 IN SDO_GEOMETRY,  
    tol   IN NUMBER  
    ) RETURN VARCHAR2;
```

Description

Examines two geometry objects to determine their spatial relationship.

Parameters

geom1

Geometry object.

dim1

Dimensional information array corresponding to `geom1`, usually selected from one of the `xxx_SDO_GEOM_METADATA` views (described in [Section 2.8](#)).

mask

Specifies a list of relationships to check. See the list of keywords in the Usage Notes.

geom2

Geometry object.

dim2

Dimensional information array corresponding to `geom2`, usually selected from one of the `xxx_SDO_GEOM_METADATA` views (described in [Section 2.8](#)).

tol

Tolerance value (see [Section 1.5.5](#)).

Usage Notes

For better performance, use the [SDO_RELATE](#) operator or one of its convenience operator formats (all described in [Chapter 19](#)) instead of the `SDO_GEOM.RELATE`

function, unless you need to use the function. For example, the DETERMINE mask keyword does not apply with the [SDO_RELATE](#) operator. For more information about performance considerations with operators and functions, see [Section 1.9](#).

The `SDO_GEOM.RELATE` function can return the following types of answers:

- If you pass a `mask` listing one or more relationships, the function returns the specified `mask` value if one or more of the relationships are true for the pair of geometries. If all relationships are false, the procedure returns `FALSE`.
- If you pass the DETERMINE keyword in `mask`, the function returns the one relationship keyword that best matches the geometries.
- If you pass the ANYINTERACT keyword in `mask`, the function returns `TRUE` if the two geometries are not disjoint.

The following `mask` relationships can be tested:

- ANYINTERACT: Returns `TRUE` if the objects are not disjoint.
- CONTAINS: Returns `CONTAINS` if the second object is entirely within the first object and the object boundaries do not touch; otherwise, returns `FALSE`.
- COVEREDBY: Returns `COVEREDBY` if the first object is entirely within the second object and the object boundaries touch at one or more points; otherwise, returns `FALSE`.
- COVERS: Returns `COVERS` if the second object is entirely within the first object and the boundaries touch in one or more places; otherwise, returns `FALSE`.
- DISJOINT: Returns `DISJOINT` if the objects have no common boundary or interior points; otherwise, returns `FALSE`.
- EQUAL: Returns `EQUAL` if the objects share every point of their boundaries and interior, including any holes in the objects; otherwise, returns `FALSE`.
- INSIDE: Returns `INSIDE` if the first object is entirely within the second object and the object boundaries do not touch; otherwise, returns `FALSE`.
- ON: Returns `ON` if the boundary and interior of a line (the first object) is completely on the boundary of a polygon (the second object); otherwise, returns `FALSE`.
- OVERLAPBDYDISJOINT: Returns `OVERLAPBDYDISJOINT` if the objects overlap, but their boundaries do not interact; otherwise, returns `FALSE`.
- OVERLAPBDYINTERSECT: Returns `OVERLAPBDYINTERSECT` if the objects overlap, and their boundaries intersect in one or more places; otherwise, returns `FALSE`.
- TOUCH: Returns `TOUCH` if the two objects share a common boundary point, but no interior points; otherwise, returns `FALSE`.

Values for `mask` can be combined using the logical Boolean operator `OR`. For example, `'INSIDE + TOUCH'` returns `INSIDE+TOUCH` if the relationship between the geometries is `INSIDE` or `TOUCH` or both `INSIDE` and `TOUCH`; it returns `FALSE` if the relationship between the geometries is neither `INSIDE` nor `TOUCH`.

An exception is raised if `geom1` and `geom2` are based on different coordinate systems.

Examples

The following example finds the relationship between each geometry in the `SHAPE` column and the `col_a_b` geometry. (The example uses the definitions and data from [Section 2.1](#). The output is reformatted for readability.)

```
SELECT c.name,  
       SDO_GEOM.RELATE(c.shape, 'determine', c_b.shape, 0.005) relationship  
FROM cola_markets c, cola_markets c_b WHERE c_b.name = 'cola_b';
```

```
NAME      RELATIONSHIP  
-----  
cola_a    TOUCH  
cola_b    EQUAL  
cola_c    OVERLAPBDYINTERSECT  
cola_d    DISJOINT
```

Related Topics

- [SDO_RELATE](#) operator

SDO_GEOM.SDO_ALPHA_SHAPE

Format

```
SDO_GEOM.SDO_ALPHA_SHAPE(
  geom IN SDO_GEOMETRY,
  tol   IN NUMBER,
  radius IN NUMBER DEFAULT NULL,
  flag  IN BINARY_INTEGER DEFAULT 0
) RETURN SDO_GEOMETRY;
```

Description

Returns the alpha shape geometry of the input geometry, based on a specified radius value.

Parameters

geom

Geometry object.

tol

Tolerance value (see [Section 1.5.5](#)).

radius

Radius to be used in calculating the alpha shape. If this parameter is null, the alpha shape is the convex hull of the input geometry.

flag

Determines whether isolated points and edges are included: 0 (the default) includes isolated points and edges, so that the alpha shape is returned; 1 does not include isolated points and edges, so that only the polygon portion of the alpha shape is returned.

Usage Notes

The **alpha shape** is a generalization of the convex hull (see <http://biogeometry.duke.edu/software/alphashapes/>). This function takes all coordinates from the input geometry, uses them to compute Delaunay triangulations and the alpha shape.

If you specify a value for the `radius` parameter, you may first want to call the [SDO_GEOM.SDO_CONCAVEHULL](#) function using the format with the `radius` output parameter.

An exception is raised if `geom` is of point type, has fewer than three points or vertices, or consists of multiple points all in a straight line, or if `radius` is less than 0.

With geodetic data, this function is supported by approximations, as explained in [Section 6.10.3](#).

Examples

The following example returns a geometry object that is the alpha shape of `cola_c`, which is also the convex hull of `cola_c` because the default value for the `radius`

parameter (null) is used. (This simplified example uses a polygon as the input geometry; this function is normally used with a large set of point data. The example uses the definitions and data from [Section 2.1](#).)

```
SELECT c.name, SDO_GEOM.SDO_ALPHA_SHAPE(c.shape, 0.005)
   FROM cola_markets c WHERE c.name = 'cola_c';

SDO_GEOM.SDO_ALPHA_SHAPE(C.SHAPE,0.005)(SDO_GTYPE, SDO_SRID, SDO_POINT(X, Y, Z),
-----
cola_c
SDO_GEOMETRY(2003, NULL, NULL, SDO_ELEM_INFO_ARRAY(1, 1003, 1), SDO_ORDINATE_ARR
AY(4, 5, 3, 3, 6, 3, 6, 5, 4, 5))
```

Related Topics

[SDO_GEOM.SDO_CONCAVEHULL](#)

[SDO_GEOM.SDO_CONVEXHULL](#)

SDO_GEOM.SDO_ARC_DENSIFY

Format

```
SDO_GEOM.SDO_ARC_DENSIFY(
    geom IN SDO_GEOMETRY,
    dim  IN SDO_DIM_ARRAY
    params IN VARCHAR2
) RETURN SDO_GEOMETRY;
```

or

```
SDO_GEOM.SDO_ARC_DENSIFY(
    geom IN SDO_GEOMETRY,
    tol  IN NUMBER
    params IN VARCHAR2
) RETURN SDO_GEOMETRY;
```

Description

Returns a geometry in which each circular arc in the input geometry is changed into an approximation of the circular arc consisting of straight lines, and each circle is changed into a polygon consisting of a series of straight lines that approximate the circle.

Parameters

geom

Geometry object.

dim

Dimensional information array corresponding to `geom`, usually selected from one of the `xxx_SDO_GEOM_METADATA` views (described in [Section 2.8](#)).

tol

Tolerance value (see [Section 1.5.5](#)).

params

A quoted string containing an arc tolerance value and optionally a unit value. See the Usage Notes for an explanation of the format and meaning.

Usage Notes

If you have geometries in a projected coordinate system that contain circles or circular arcs, you can use this function to densify them into regular polygons. You can then use the resulting straight-line polygon geometries for any Spatial operations, or you can transform them to any projected or geodetic coordinate system.

The `params` parameter is a quoted string that can contain the `arc_tolerance` keyword, as well as the `unit` keyword to identify the unit of measurement associated with the `arc_tolerance` value. For example:

```
'arc_tolerance=0.05 unit=km'
```

The `arc_tolerance` keyword specifies, for each arc in the geometry, the maximum length of the perpendicular line between the surface of the arc and the straight line between the start and end points of the arc. [Figure 24–1](#) shows a line whose length is the `arc_tolerance` value for the arc between points A and B.

Figure 24–1 Arc Tolerance

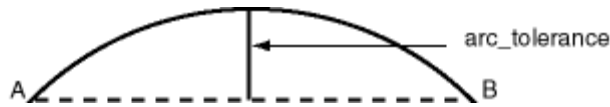

The `arc_tolerance` keyword value must be greater than the tolerance value associated with the geometry. (The default value for `arc_tolerance` is 20 times the tolerance value.) As you increase the `arc_tolerance` keyword value, the resulting polygon has fewer sides and a smaller area; as you decrease the `arc_tolerance` keyword value, the resulting polygon has more sides and a larger area (but never larger than the original geometry).

If the `unit` keyword is specified, the value must be an `SDO_UNIT` value from the `MDSYS.SDO_DIST_UNITS` table (for example, `'unit=KM'`). If the `unit` keyword is not specified, the unit of measurement associated with the geometry is used. See [Section 2.10](#) for more information about unit of measurement specification.

Examples

The following example returns the geometry that results from the arc densification of `cola_d`, which is a circle. (The example uses the definitions and data from [Section 2.1](#).)

```
-- Arc densification of the circle cola_d
SELECT c.name, SDO_GEOM.SDO_ARC_DENSIFY(c.shape, m.diminfo,
                                         'arc_tolerance=0.05')
FROM cola_markets c, user_sdo_geom_metadata m
WHERE m.table_name = 'COLA_MARKETS' AND m.column_name = 'SHAPE'
AND c.name = 'cola_d';

NAME
-----
SDO_GEOM.SDO_ARC_DENSIFY(C.SHAPE,M.DIMINFO,'ARC_TOLERANCE=0.05')(SDO_GTYPE, SDO_
-----
cola_d
SDO_GEOMETRY(2003, NULL, NULL, SDO_ELEM_INFO_ARRAY(1, 1003, 1), SDO_ORDINATE_ARR
AY(8, 7, 8.76536686, 7.15224093, 9.41421356, 7.58578644, 9.84775907, 8.23463314,
 10, 9, 9.84775907, 9.76536686, 9.41421356, 10.4142136, 8.76536686, 10.8477591,
8, 11, 7.23463314, 10.8477591, 6.58578644, 10.4142136, 6.15224093, 9.76536686, 6
, 9, 6.15224093, 8.23463314, 6.58578644, 7.58578644, 7.23463314, 7.15224093, 8,
7))
```

Related Topics

- [Section 6.2.5, "Other Considerations and Requirements with Geodetic Data"](#)

SDO_GEOM.SDO_AREA

Format

```
SDO_GEOM.SDO_AREA(
    geom IN SDO_GEOMETRY,
    dim  IN SDO_DIM_ARRAY
    [, unit IN VARCHAR2]
) RETURN NUMBER;
```

or

```
SDO_GEOM.SDO_AREA(
    geom IN SDO_GEOMETRY,
    tol  IN NUMBER
    [, unit IN VARCHAR2]
) RETURN NUMBER;
```

Description

Returns the area of a two-dimensional polygon.

Parameters

geom

Geometry object.

dim

Dimensional information array corresponding to `geom`, usually selected from one of the `xxx_SDO_GEOM_METADATA` views (described in [Section 2.8](#)).

unit

Unit of measurement: a quoted string with `unit=` and an `SDO_UNIT` value from the `MDSYS.SDO_AREA_UNITS` table (for example, 'unit=SQ_KM'). See [Section 2.10](#) for more information about unit of measurement specification.

If this parameter is not specified, the unit of measurement associated with the data is assumed. For geodetic data, the default unit of measurement is square meters.

tol

Tolerance value (see [Section 1.5.5](#)).

Usage Notes

This function works with any polygon, including polygons with holes.

Lines that close to form a ring have no area.

Examples

The following example returns the areas of geometry objects stored in the `COLA_MARKETS` table. The first statement returns the areas of all objects; the second returns just the area of `cola_a`. (The example uses the definitions and data from [Section 2.1](#).)

```
-- Return the areas of all cola markets.
SELECT name, SDO_GEOM.SDO_AREA(shape, 0.005) FROM cola_markets;

NAME                                SDO_GEOM.SDO_AREA(SHAPE,0.005)
-----
cola_a                                24
cola_b                                16.5
cola_c                                5
cola_d                                12.5663706

-- Return the area of just cola_a.
SELECT c.name, SDO_GEOM.SDO_AREA(c.shape, 0.005) FROM cola_markets c
       WHERE c.name = 'cola_a';

NAME                                SDO_GEOM.SDO_AREA(C.SHAPE,0.005)
-----
cola_a                                24
```

Related Topics

None.

SDO_GEOM.SDO_BUFFER

Format

```
SDO_GEOM.SDO_BUFFER(
    geom    IN SDO_GEOMETRY,
    dim     IN SDO_DIM_ARRAY,
    dist    IN NUMBER
    [, params IN VARCHAR2]
) RETURN SDO_GEOMETRY;
```

or

```
SDO_GEOM.SDO_BUFFER(
    geom    IN SDO_GEOMETRY,
    dist    IN NUMBER,
    tol     IN NUMBER
    [, params IN VARCHAR2]
) RETURN SDO_GEOMETRY;
```

Description

Generates a buffer polygon around or inside a geometry object.

Parameters

geom

Geometry object.

dim

Dimensional information array corresponding to `geom`, usually selected from one of the `xxx_SDO_GEOM_METADATA` views (described in [Section 2.8](#)).

dist

Distance value. If the value is positive, the buffer is generated around the geometry; if the value is negative (valid only for polygons), the buffer is generated inside the geometry. The absolute value of this parameter must be greater than the tolerance value, as specified in the dimensional array (`dim` parameter) or in the `tol` parameter.

tol

Tolerance value (see [Section 1.5.5](#)).

params

A quoted string that can contain one or both of the following keywords:

- `unit` and an `SDO_UNIT` value from the `MDSYS.SDO_DIST_UNITS` table. It identifies the unit of measurement associated with the `dist` parameter value, and also with the arc tolerance value if the `arc_tolerance` keyword is specified. See [Section 2.10](#) for more information about unit of measurement specification.

- `arc_tolerance` and an arc tolerance value. See the Usage Notes for the [SDO_GEOM.SDO_ARC_DENSIFY](#) function in this chapter for more information about the `arc_tolerance` keyword.

For example: `'unit=km arc_tolerance=0.05'`

If the input geometry is geodetic data and if `arc_tolerance` is not specified, the default value is the tolerance value multiplied by 20. Spatial uses the `arc_tolerance` value to perform arc densification in computing the result. If the input geometry is Cartesian or projected data, `arc_tolerance` has no effect and should not be specified.

If this parameter is not specified for a Cartesian or projected geometry, or if the `arc_tolerance` keyword is specified for a geodetic geometry but the `unit` keyword is not specified, the unit of measurement associated with the data is assumed.

Usage Notes

This function returns a geometry object representing the buffer polygon.

This function creates a rounded buffer around a point, line, or polygon, or inside a polygon. The buffer within a void is also rounded, and is the same distance from the inner boundary as the outer buffer is from the outer boundary. See [Figure 1-7](#) for an illustration.

If the buffer polygon geometry is in a projected coordinate system, it will contain arcs; and if you want to transform that geometry to a geodetic coordinate system, you must first densify it using the [SDO_GEOM.SDO_ARC_DENSIFY](#) function, and then transform the densified geometry.

With geodetic data, this function is supported by approximations, as explained in [Section 6.10.3](#).

With geodetic data, this function should be used only for relatively small geometries: geometries for which the local tangent plane projection that is used for internal computations does not introduce significant distortions or errors. This limits the applicable domain of source geometries, whether line strings or polygons, to approximately the area of Texas (United States), France, or Manchuria province (China).

Examples

The following example returns a polygon representing a buffer of 1 around `cola_a`. Note the rounded corners (for example, at `.292893219,.292893219`) in the returned polygon. (The example uses the non-geodetic definitions and data from [Section 2.1](#).)

```
-- Generate a buffer of 1 unit around a geometry.
SELECT c.name, SDO_GEOM.SDO_BUFFER(c.shape, m.diminfo, 1)
   FROM cola_markets c, user_sdo_geom_metadata m
   WHERE m.table_name = 'COLA_MARKETS' AND m.column_name = 'SHAPE'
   AND c.name = 'cola_a';

NAME
-----
SDO_GEOM.SDO_BUFFER(C.SHAPE,M.DIMINFO,1) (SDO_GTYPE, SDO_SRID, SDO_POINT(X, Y, Z))
-----
cola_a
SDO_GEOMETRY(2003, NULL, NULL, SDO_ELEM_INFO_ARRAY(1, 1005, 8, 1, 2, 2, 5, 2, 1,
7, 2, 2, 11, 2, 1, 13, 2, 2, 17, 2, 1, 19, 2, 2, 23, 2, 1), SDO_ORDINATE_ARRAY(
0, 1, .292893219, .292893219, 1, 0, 5, 0, 5.70710678, .292893219, 6, 1, 6, 7, 5.
70710678, 7.70710678, 5, 8, 1, 8, .292893219, 7.70710678, 0, 7, 0, 1))
```

The following example returns a polygon representing a buffer of 1 around cola_a using the geodetic definitions and data from [Section 6.13](#).

```
-- Generate a buffer of 1 kilometer around a geometry.
SELECT c.name, SDO_GEOM.SDO_BUFFER(c.shape, m.diminfo, 1,
                                   'unit=km arc_tolerance=0.05')
FROM cola_markets c, user_sdo_geom_metadata m
WHERE m.table_name = 'COLA_MARKETS'
AND m.column_name = 'SHAPE' AND c.name = 'cola_a';

NAME
-----
SDO_GEOM.SDO_BUFFER(C.SHAPE,M.DIMINFO,1,'UNIT=KMARC_TOLERANCE=0.05')(SDO_GTYPE,
-----
cola_a
SDO_GEOMETRY(2003, 8307, NULL, SDO_ELEM_INFO_ARRAY(1, 1003, 1), SDO_ORDINATE_ARR
AY(.991023822, 1.00002073, .992223711, .995486419, .99551726, .99217077, 1.00001
929, .990964898, 4.99998067, .990964929, 5.00448268, .9921708, 5.00777624, .9954
86449, 5.00897618, 1.00002076, 5.00904194, 6.99997941, 5.00784065, 7.00450033, 5
.00454112, 7.00781357, 5.00002479, 7.009034, .999975166, 7.00903403, .995458814,
7.00781359, .992159303, 7.00450036, .990958058, 6.99997944, .991023822, 1.00002
073))
```

Related Topics

- [SDO_GEOM.SDO_UNION](#)
- [SDO_GEOM.SDO_INTERSECTION](#)
- [SDO_GEOM.SDO_XOR](#)

SDO_GEOM.SDO_CENTROID

Format

```
SDO_GEOM.SDO_CENTROID(  
    geom1 IN SDO_GEOMETRY,  
    dim1  IN SDO_DIM_ARRAY  
    ) RETURN SDO_GEOMETRY;
```

or

```
SDO_GEOM.SDO_CENTROID(  
    geom1 IN SDO_GEOMETRY,  
    tol   IN NUMBER  
    ) RETURN SDO_GEOMETRY;
```

Description

Returns a point geometry that is the centroid of a polygon, multipolygon, point, or point cluster. (The centroid is also known as the "center of gravity.")

For an input geometry consisting of multiple objects, the result is weighted by the area of each polygon in the geometry objects. If the geometry objects are a mixture of polygons and points, the points are not used in the calculation of the centroid. If the geometry objects are all points, the points have equal weight.

Parameters

geom1

Geometry object.

dim1

Dimensional information array corresponding to `geom`, usually selected from one of the `xxx_SDO_GEOM_METADATA` views (described in [Section 2.8](#)).

tol

Tolerance value (see [Section 1.5.5](#)).

Usage Notes

The function returns a null value if `geom1` is not a polygon, multipolygon, point, or point cluster, as identified by the `SDO_GTYPE` value in the `SDO_GEOMETRY` object.

If `geom1` is a point, the function returns the point (the input geometry).

With geodetic data, this function is supported by approximations, as explained in [Section 6.10.3](#).

Depending on the shape and complexity of the input geometry, the returned point might not be on the surface of the input geometry.

Examples

The following example returns a geometry object that is the centroid of `cola_c`. (The example uses the definitions and data from [Section 2.1](#).)

```
-- Return the centroid of a geometry.
SELECT c.name, SDO_GEOM.SDO_CENTROID(c.shape, m.diminfo)
   FROM cola_markets c, user_sdo_geom_metadata m
   WHERE m.table_name = 'COLA_MARKETS' AND m.column_name = 'SHAPE'
   AND c.name = 'cola_c';

NAME
-----
SDO_GEOM.SDO_CENTROID(C.SHAPE,M.DIMINFO)(SDO_GTYPE, SDO_SRID, SDO_POINT(X, Y, Z)
-----
cola_c
SDO_GEOMETRY(2001, NULL, NULL, SDO_ELEM_INFO_ARRAY(1, 1, 1), SDO_ORDINATE_ARRAY(
4.73333333, 3.93333333))
```

Related Topics

None.

SDO_GEOM.SDO_CLOSEST_POINTS

Format

```
SDO_GEOM.SDO_CLOSEST_POINTS(  
    geom1    IN SDO_GEOMETRY,  
    geom2    IN SDO_GEOMETRY,  
    tolerance IN NUMBER,  
    unit     IN VARCHAR2,  
    dist     OUT NUMBER,  
    geoma    OUT SDO_GEOMETRY,  
    geomb    OUT SDO_GEOMETRY);
```

Description

Computes the minimum distance between two geometries and the points (one on each geometry) that are the minimum distance apart.

Parameters

geom1

Geometry object.

geom2

Geometry object.

tolerance

Tolerance value (see [Section 1.5.5](#)).

unit

Unit of measurement: a quoted string with `unit=` and an `SDO_UNIT` value from the `MDSYS.SDO_DIST_UNITS` table (for example, `'unit=KM'`). See [Section 2.10](#) for more information about unit of measurement specification.

If this parameter is not specified, the unit of measurement associated with the data is assumed.

dist

Output parameter containing the minimum distance between `geom1` and `geom2`. Specifically, the distance between `geoma` and `geomb`.

geoma

Output parameter containing the point geometry object on the boundary of `geom1` that is closest to the closest point on the boundary of `geom2`.

geomb

Output parameter containing the point geometry object on the boundary of `geom2` that is closest to the closest point on the boundary of `geom1`.

Usage Notes

This procedure uses output parameters to store the computed minimum distance and the point on each input geometry associated with the minimum distance.

Examples

The following example computes the minimum distance between geometries `cola_c` and `cola_d`, as well as the one point on each input geometry associated with the minimum distance. It also inserts the two output point geometries into the table and then selects these point geometries. The minimum distance between the two input geometries is 2.47213595499958, the closest point on `cola_c` is at (6,5), and the closest point on `cola_d` is at (7.10557281, 7.21114562). (The example uses the definitions and data from [Section 2.1](#).)

```

DECLARE
  cola_c_geom SDO_GEOMETRY;
  cola_d_geom SDO_GEOMETRY;
  dist NUMBER;
  geoma SDO_GEOMETRY;
  geomb SDO_GEOMETRY;

BEGIN

  -- Populate geometry variables with cola market shapes.
  SELECT c.shape into cola_c_geom FROM cola_markets c
     WHERE c.name = 'cola_c';
  SELECT c.shape into cola_d_geom FROM cola_markets c
     WHERE c.name = 'cola_d';

  SDO_GEOM.SDO_CLOSEST_POINTS(cola_c_geom, cola_d_geom, 0.005, NULL,
    dist, geoma, geomb);

  INSERT INTO cola_markets VALUES(9901, 'geoma', geoma);
  INSERT INTO cola_markets VALUES(9902, 'geomb', geomb);

  DBMS_OUTPUT.PUT_LINE('dist output parameter value = ' || dist);
END;
/
dist output parameter value = 2.47213595499958

PL/SQL procedure successfully completed.

SELECT c.shape FROM cola_markets c WHERE c.name = 'geoma';

SHAPE(SDO_GTYPE, SDO_SRID, SDO_POINT(X, Y, Z), SDO_ELEM_INFO, SDO_ORDINATES)
-----
SDO_GEOMETRY(2001, NULL, NULL, SDO_ELEM_INFO_ARRAY(1, 1, 1), SDO_ORDINATE_ARRAY(
6, 5))

SELECT c.shape FROM cola_markets c WHERE c.name = 'geomb';

SHAPE(SDO_GTYPE, SDO_SRID, SDO_POINT(X, Y, Z), SDO_ELEM_INFO, SDO_ORDINATES)
-----
SDO_GEOMETRY(2001, NULL, NULL, SDO_ELEM_INFO_ARRAY(1, 1, 1), SDO_ORDINATE_ARRAY(
7.10557281, 7.21114562))

```

Related Topics

None.

SDO_GEOM.SDO_CONCAVEHULL

Format

```
SDO_GEOM.SDO_CONCAVEHULL(  
    geom IN SDO_GEOMETRY,  
    tol   IN NUMBER  
    ) RETURN SDO_GEOMETRY;
```

or

```
SDO_GEOM.SDO_CONCAVEHULL(  
    geom IN SDO_GEOMETRY,  
    tol   IN NUMBER,  
    radius OUT NUMBER  
    ) RETURN SDO_GEOMETRY;
```

Description

Returns a polygon-type object that represents the concave hull of a geometry object.

Parameters

geom

Geometry object.

tol

Tolerance value (see [Section 1.5.5](#)).

radius

Output parameter to hold the radius of the circumcircle of the triangles created internally (using Delaunay triangulations) in computing the concave hull.

Usage Notes

The **concave hull** is a polygon that represents the area of the input geometry, such as a collection of points. With complex input geometries, the concave hull is typically significantly smaller in area than the convex hull.

This function takes all coordinates from the input geometry, uses them to compute Delaunay triangulations, and computes a concave hull. It returns only an exterior ring; any interior rings are discarded.

This function uses the alpha shape in computing the concave hull. By contrast, the [SDO_GEOM.SDO_CONCAVEHULL_BOUNDARY](#) function uses exterior boundary points.

The format with the `radius` parameter returns a radius value that can be useful if you plan to call the [SDO_GEOM.SDO_ALPHA_SHAPE](#) function.

An exception is raised if `geom` has fewer than three points or vertices, or consists of multiple points all in a straight line.

With geodetic data, this function is supported by approximations, as explained in [Section 6.10.3](#).

Examples

The following example returns a geometry object that is the concave hull of cola_c. (The example uses the definitions and data from [Section 2.1](#).)

```
-- Return the concave hull of a polygon.
SELECT c.name, SDO_GEOM.SDO_CONCAVEHULL(c.shape, 0.005)
   FROM cola_markets c WHERE c.name = 'cola_c';

NAME
-----
SDO_GEOM.SDO_CONCAVEHULL(C.SHAPE,0.005)(SDO_GTYPE, SDO_SRID, SDO_POINT(X, Y, Z),
-----
cola_c
SDO_GEOMETRY(2003, NULL, NULL, SDO_ELEM_INFO_ARRAY(1, 1003, 1), SDO_ORDINATE_ARR
AY(6, 3, 6, 5, 4, 5, 3, 3, 6, 3))
```

Related Topics

[SDO_GEOM.SDO_ALPHA_SHAPE](#)

[SDO_GEOM.SDO_CONCAVEHULL_BOUNDARY](#)

[SDO_GEOM.SDO_CONVEXHULL](#)

SDO_GEOM.SDO_CONCAVEHULL_BOUNDARY

Format

```
SDO_GEOM.SDO_CONCAVEHULL_BOUNDARY(  
    geom IN SDO_GEOMETRY,  
    tol   IN NUMBER,  
    length IN NUMBER DEFAULT NULL  
    ) RETURN SDO_GEOMETRY;
```

Description

Returns a polygon-type object that represents the concave hull of a geometry object, based on boundary points rather than the alpha shape.

Parameters

geom

Geometry object.

tol

Tolerance value (see [Section 1.5.5](#)).

length

A value to control the size of the concave hull: specifically, computation of the concave hull is stopped when the longest edge in the concave hull is shorter than the `length` value. Thus, the larger the `length` value, the larger the concave hull will probably be. If you do not specify this parameter, computation continues as described in the Usage Notes.

Usage Notes

The **concave hull** is a polygon that represents the area of the input geometry, such as a collection of points. With complex input geometries, the concave hull is typically significantly smaller in area than the convex hull.

Like the [SDO_GEOM.SDO_CONCAVEHULL](#) function, this function takes all coordinates from the input geometry, and uses them to compute Delaunay triangulations. But after that, it computes a convex hull, puts all boundary edges into a priority queue based on the lengths of these edges, and then removes edges one by one as long as the shape is still a single connected polygon (unless stopped by a specified `length` parameter value). If an edge is removed during the computation, the other two edges of its triangle will be on the boundary.

An exception is raised if `geom` has fewer than three points or vertices, or consists of multiple points all in a straight line.

With geodetic data, this function is supported by approximations, as explained in [Section 6.10.3](#).

Examples

The following example returns a geometry object that is the concave hull of `cola_c`. (The example uses the definitions and data from [Section 2.1](#).)

```
-- Return the concave hull of a polygon.
SELECT c.name, SDO_GEOM.SDO_CONCAVEHULL_BOUNDARY(c.shape, 0.005)
   FROM cola_markets c WHERE c.name = 'cola_c';

NAME
-----
SDO_GEOM.SDO_CONCAVEHULL_BOUNDARY(C.SHAPE,0.005)(SDO_GTYPE, SDO_SRID, SDO_POINT(
-----
cola_c
SDO_GEOMETRY(2003, NULL, NULL, SDO_ELEM_INFO_ARRAY(1, 1003, 1), SDO_ORDINATE_ARR
AY(6, 3, 6, 5, 4, 5, 3, 3, 6, 3))
```

Related Topics

[SDO_GEOM.SDO_ALPHA_SHAPE](#)
[SDO_GEOM.SDO_CONCAVEHULL](#)
[SDO_GEOM.SDO_CONVEXHULL](#)

SDO_GEOM.SDO_CONVEXHULL

Format

```
SDO_GEOM.SDO_CONVEXHULL(  
    geom1 IN SDO_GEOMETRY,  
    dim1  IN SDO_DIM_ARRAY  
    ) RETURN SDO_GEOMETRY;
```

or

```
SDO_GEOM.SDO_CONVEXHULL(  
    geom1 IN SDO_GEOMETRY,  
    tol   IN NUMBER  
    ) RETURN SDO_GEOMETRY;
```

Description

Returns a polygon-type object that represents the convex hull of a geometry object.

Parameters

geom1

Geometry object.

dim1

Dimensional information array corresponding to `geom1`, usually selected from one of the `xxx_SDO_GEOM_METADATA` views (described in [Section 2.8](#)).

tol

Tolerance value (see [Section 1.5.5](#)).

Usage Notes

The **convex hull** is a simple convex polygon that completely encloses the geometry object. Spatial uses as few straight-line sides as possible to create the smallest polygon that completely encloses the specified object. A convex hull is a convenient way to get an approximation of a complex geometry object.

If the geometry (`geom1`) contains any arc elements, the function calculates the minimum bounding rectangle (MBR) for each arc element and uses these MBRs in calculating the convex hull of the geometry. If the geometry object (`geom1`) is a circle, the function returns a square that minimally encloses the circle.

The function returns a null value if `geom1` is of point type, has fewer than three points or vertices, or consists of multiple points all in a straight line.

With geodetic data, this function is supported by approximations, as explained in [Section 6.10.3](#).

Examples

The following example returns a geometry object that is the convex hull of `cola_c`. (The example uses the definitions and data from [Section 2.1](#). This specific example,

however, does not produce useful output—the returned polygon has the same vertices as the input polygon—because the input polygon is already a simple convex polygon.)

```
-- Return the convex hull of a polygon.
SELECT c.name, SDO_GEOM.SDO_CONVEXHULL(c.shape, m.diminfo)
   FROM cola_markets c, user_sdo_geom_metadata m
   WHERE m.table_name = 'COLA_MARKETS' AND m.column_name = 'SHAPE'
   AND c.name = 'cola_c';

NAME
-----
SDO_GEOM.SDO_CONVEXHULL(C.SHAPE,M.DIMINFO) (SDO_GTYPE, SDO_SRID, SDO_POINT(X, Y,
-----
cola_c
SDO_GEOMETRY(2003, NULL, NULL, SDO_ELEM_INFO_ARRAY(1, 1003, 1), SDO_ORDINATE_ARR
AY(6, 3, 6, 5, 4, 5, 3, 3, 6, 3))
```

Related Topics

[SDO_GEOM.SDO_CONCAVEHULL](#)

SDO_GEOM.SDO_DIFFERENCE

Format

```
SDO_GEOM.SDO_DIFFERENCE(  
    geom1 IN SDO_GEOMETRY,  
    dim1  IN SDO_DIM_ARRAY,  
    geom2 IN SDO_GEOMETRY,  
    dim2  IN SDO_DIM_ARRAY  
    ) RETURN SDO_GEOMETRY;
```

or

```
SDO_GEOM.SDO_DIFFERENCE(  
    geom1 IN SDO_GEOMETRY,  
    geom2 IN SDO_GEOMETRY,  
    tol   IN NUMBER  
    ) RETURN SDO_GEOMETRY;
```

Description

Returns a geometry object that is the topological difference (MINUS operation) of two geometry objects.

Parameters

geom1

Geometry object.

dim1

Dimensional information array corresponding to `geom1`, usually selected from one of the `xxx_SDO_GEOM_METADATA` views (described in [Section 2.8](#)).

geom2

Geometry object.

dim2

Dimensional information array corresponding to `geom2`, usually selected from one of the `xxx_SDO_GEOM_METADATA` views (described in [Section 2.8](#)).

tol

Tolerance value (see [Section 1.5.5](#)).

Usage Notes

In [Figure 24-2](#), the shaded area represents the polygon returned when `SDO_DIFFERENCE` is used with a square (`geom1`) and another polygon (`geom2`).

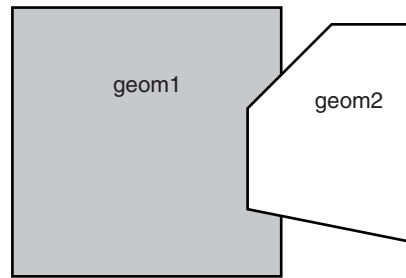
Figure 24–2 SDO_GEOM.SDO_DIFFERENCE

An exception is raised if geom1 and geom2 are based on different coordinate systems.

Examples

The following example returns a geometry object that is the topological difference (MINUS operation) of cola_a and cola_c. (The example uses the definitions and data from [Section 2.1](#).)

```
-- Return the topological difference of two geometries.
SELECT SDO_GEOM.SDO_DIFFERENCE(c_a.shape, m.diminfo, c_c.shape, m.diminfo)
  FROM cola_markets c_a, cola_markets c_c, user_sdo_geom_metadata m
  WHERE m.table_name = 'COLA_MARKETS' AND m.column_name = 'SHAPE'
  AND c_a.name = 'cola_a' AND c_c.name = 'cola_c';

SDO_GEOM.SDO_DIFFERENCE(C_A.SHAPE,M.DIMINFO,C_C.SHAPE,M.DIMINFO) (SDO_GTYPE, SDO_
-----
SDO_GEOMETRY(2003, NULL, NULL, SDO_ELEM_INFO_ARRAY(1, 1003, 1), SDO_ORDINATE_ARR
AY(1, 7, 1, 1, 5, 1, 5, 3, 3, 3, 4, 5, 5, 5, 5, 7, 1, 7))
```

Note that in the returned polygon, the SDO_ORDINATE_ARRAY starts and ends at the same point (1, 7).

Related Topics

- [SDO_GEOM.SDO_INTERSECTION](#)
- [SDO_GEOM.SDO_UNION](#)
- [SDO_GEOM.SDO_XOR](#)

SDO_GEOM.SDO_DISTANCE

Format

```
SDO_GEOM.SDO_DISTANCE(  
    geom1 IN SDO_GEOMETRY,  
    dim1  IN SDO_DIM_ARRAY,  
    geom2 IN SDO_GEOMETRY,  
    dim2  IN SDO_DIM_ARRAY  
    [, unit IN VARCHAR2]  
    ) RETURN NUMBER;
```

or

```
SDO_GEOM.SDO_DISTANCE(  
    geom1 IN SDO_GEOMETRY,  
    geom2 IN SDO_GEOMETRY,  
    tol   IN NUMBER  
    [, unit IN VARCHAR2]  
    ) RETURN NUMBER;
```

Description

Computes the distance between two geometry objects. The distance between two geometry objects is the distance between the closest pair of points or segments of the two objects.

Parameters

geom1

Geometry object whose distance from `geom2` is to be computed.

dim1

Dimensional information array corresponding to `geom1`, usually selected from one of the `xxx_SDO_GEOM_METADATA` views (described in [Section 2.8](#)).

geom2

Geometry object whose distance from `geom1` is to be computed.

dim2

Dimensional information array corresponding to `geom2`, usually selected from one of the `xxx_SDO_GEOM_METADATA` views (described in [Section 2.8](#)).

unit

Unit of measurement: a quoted string with `unit=` and an `SDO_UNIT` value from the `MDSYS.SDO_DIST_UNITS` table (for example, 'unit=KM'). See [Section 2.10](#) for more information about unit of measurement specification.

If this parameter is not specified, the unit of measurement associated with the data is assumed.

tol

Tolerance value (see [Section 1.5.5](#)).

Usage Notes

An exception is raised if geom1 and geom2 are based on different coordinate systems.

Examples

The following example returns the shortest distance between cola_b and cola_d. (The example uses the definitions and data from [Section 2.1](#).)

```
-- Return the distance between two geometries.  
SELECT SDO_GEOM.SDO_DISTANCE(c_b.shape, c_d.shape, 0.005)  
       FROM cola_markets c_b, cola_markets c_d  
       WHERE c_b.name = 'cola_b' AND c_d.name = 'cola_d';
```

```
SDO_GEOM.SDO_DISTANCE(C_B.SHAPE,C_D.SHAPE,0.005)  
-----  
                                         .846049894
```

Related Topics

- [SDO_GEOM.WITHIN_DISTANCE](#)

SDO_GEOM.SDO_INTERSECTION

Format

```
SDO_GEOM.SDO_INTERSECTION(  
    geom1 IN SDO_GEOMETRY,  
    dim1  IN SDO_DIM_ARRAY,  
    geom2 IN SDO_GEOMETRY,  
    dim2  IN SDO_DIM_ARRAY  
    ) RETURN SDO_GEOMETRY;
```

or

```
SDO_GEOM.SDO_INTERSECTION(  
    geom1 IN SDO_GEOMETRY,  
    geom2 IN SDO_GEOMETRY,  
    tol   IN NUMBER  
    ) RETURN SDO_GEOMETRY;
```

Description

Returns a geometry object that is the topological intersection (AND operation) of two geometry objects.

Parameters

geom1

Geometry object.

dim1

Dimensional information array corresponding to `geom1`, usually selected from one of the `xxx_SDO_GEOM_METADATA` views (described in [Section 2.8](#)).

geom2

Geometry object.

dim2

Dimensional information array corresponding to `geom2`, usually selected from one of the `xxx_SDO_GEOM_METADATA` views (described in [Section 2.8](#)).

tol

Tolerance value (see [Section 1.5.5](#)).

Usage Notes

In [Figure 24-3](#), the shaded area represents the polygon returned when `SDO_INTERSECTION` is used with a square (`geom1`) and another polygon (`geom2`).

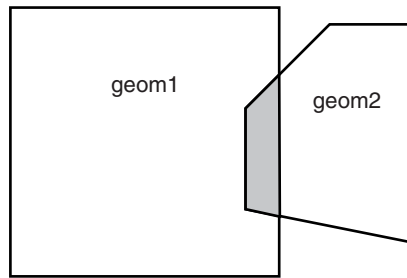
Figure 24–3 SDO_GEOM.SDO_INTERSECTION

An exception is raised if geom1 and geom2 are based on different coordinate systems.

Examples

The following example returns a geometry object that is the topological intersection (AND operation) of cola_a and cola_c. (The example uses the definitions and data from [Section 2.1](#).)

```
-- Return the topological intersection of two geometries.
SELECT SDO_GEOM.SDO_INTERSECTION(c_a.shape, c_c.shape, 0.005)
       FROM cola_markets c_a, cola_markets c_c
       WHERE c_a.name = 'cola_a' AND c_c.name = 'cola_c';

SDO_GEOM.SDO_INTERSECTION(C_A.SHAPE,C_C.SHAPE,0.005) (SDO_GTYPE, SDO_SRID, SDO_PO
-----
SDO_GEOMETRY(2003, NULL, NULL, SDO_ELEM_INFO_ARRAY(1, 1003, 1), SDO_ORDINATE_ARR
AY(4, 5, 3, 3, 5, 3, 5, 5, 4, 5))
```

Note that in the returned polygon, the SDO_ORDINATE_ARRAY starts and ends at the same point (4, 5).

Related Topics

- [SDO_GEOM.SDO_DIFFERENCE](#)
- [SDO_GEOM.SDO_UNION](#)
- [SDO_GEOM.SDO_XOR](#)

SDO_GEOM.SDO_LENGTH

Format

```
SDO_GEOM.SDO_LENGTH(  
    geom IN SDO_GEOMETRY,  
    dim  IN SDO_DIM_ARRAY  
    [, unit IN VARCHAR2]  
    [, count_shared_edges IN NUMBER]  
    ) RETURN NUMBER;
```

or

```
SDO_GEOM.SDO_LENGTH(  
    geom IN SDO_GEOMETRY,  
    tol  IN NUMBER  
    [, unit IN VARCHAR2]  
    [, count_shared_edges IN NUMBER]  
    ) RETURN NUMBER;
```

Description

Returns the length or perimeter of a geometry object.

Parameters

geom

Geometry object.

dim

Dimensional information array corresponding to `geom`, usually selected from one of the `xxx_SDO_GEOM_METADATA` views (described in [Section 2.8](#)).

tol

Tolerance value (see [Section 1.5.5](#)).

unit

Unit of measurement: a quoted string with `unit=` and an `SDO_UNIT` value from the `MDSYS.SDO_DIST_UNITS` table (for example, `'unit=KM'`). See [Section 2.10](#) for more information about unit of measurement specification.

If this parameter is not specified, the unit of measurement associated with the data is assumed. For geodetic data, the default unit of measurement is meters.

count_shared_edges

For three-dimensional geometries only: the number of times to count the length of shared parts of edges if the input geometry contains any edges that are fully or partially shared. If specified, must be 1 (count each once) or 2 (count each twice). The default is 1.

This parameter is ignored for two-dimensional input geometries.

Usage Notes

If the input polygon contains one or more holes, this function calculates the perimeters of the exterior boundary and all holes. It returns the sum of all perimeters.

Examples

The following example returns the perimeters of geometry objects stored in the COLA_MARKETS table. The first statement returns the perimeters of all objects; the second returns just the perimeter of cola_a. (The example uses the definitions and data from [Section 2.1](#).)

```
-- Return the perimeters of all cola markets.
SELECT c.name, SDO_GEOM.SDO_LENGTH(c.shape, m.diminfo)
   FROM cola_markets c, user_sdo_geom_metadata m
   WHERE m.table_name = 'COLA_MARKETS' AND m.column_name = 'SHAPE';
```

NAME	SDO_GEOM.SDO_LENGTH(C.SHAPE,M.DIMINFO)
cola_a	20
cola_b	17.1622777
cola_c	9.23606798
cola_d	12.5663706

```
-- Return the perimeter of just cola_a.
SELECT c.name, SDO_GEOM.SDO_LENGTH(c.shape, m.diminfo)
   FROM cola_markets c, user_sdo_geom_metadata m
   WHERE m.table_name = 'COLA_MARKETS' AND m.column_name = 'SHAPE'
   AND c.name = 'cola_a';
```

NAME	SDO_GEOM.SDO_LENGTH(C.SHAPE,M.DIMINFO)
cola_a	20

Related Topics

None.

SDO_GEOM.SDO_MAX_MBR_ORDINATE

Format

```
SDO_GEOM.SDO_MAX_MBR_ORDINATE(  
    geom          IN SDO_GEOMETRY,  
    ordinate_pos  IN NUMBER  
    ) RETURN NUMBER;
```

or

```
SDO_GEOM.SDO_MAX_MBR_ORDINATE(  
    geom          IN SDO_GEOMETRY,  
    dim           IN SDO_DIM_ARRAY,  
    ordinate_pos  IN NUMBER  
    ) RETURN NUMBER;
```

Description

Returns the maximum value for the specified ordinate (dimension) of the minimum bounding rectangle of a geometry object.

Parameters

geom

Geometry object.

dim

Dimensional information array corresponding to *geom*, usually selected from one of the *xxx_SDO_GEOM_METADATA* views (described in [Section 2.8](#)).

ordinate_pos

Position of the ordinate (dimension) in the definition of the geometry object: 1 for the first ordinate, 2 for the second ordinate, and so on. For example, if *geom* has X, Y ordinates, 1 identifies the X ordinate and 2 identifies the Y ordinate.

Usage Notes

None.

Examples

The following example returns the maximum X (first) ordinate value of the minimum bounding rectangle of the *cola_d* geometry in the *COLA_MARKETS* table. (The example uses the definitions and data from [Section 2.1](#). The minimum bounding rectangle of *cola_d* is returned in the example for the [SDO_GEOM.SDO_MBR](#) function.)

```
SELECT SDO_GEOM.SDO_MAX_MBR_ORDINATE(c.shape, m.diminfo, 1)  
FROM cola_markets c, user_sdo_geom_metadata m  
WHERE m.table_name = 'COLA_MARKETS' AND m.column_name = 'SHAPE'  
AND c.name = 'cola_d';
```

```
SDO_GEOM.SDO_MAX_MBR_ORDINATE(C.SHAPE,M.DIMINFO,1)
```

10**Related Topics**

- [SDO_GEOM.SDO_MBR](#)
- [SDO_GEOM.SDO_MIN_MBR_ORDINATE](#)

SDO_GEOM.SDO_MBR

Format

```
SDO_GEOM.SDO_MBR(
  geom IN SDO_GEOMETRY
  [, dim IN SDO_DIM_ARRAY]
) RETURN SDO_GEOMETRY;
```

Description

Returns the minimum bounding rectangle of a geometry object, that is, a single rectangle that minimally encloses the geometry.

Parameters

geom

Geometry object.

dim

Dimensional information array corresponding to `geom`, usually selected from one of the `xxx_SDO_GEOM_METADATA` views (described in [Section 2.8](#)).

Usage Notes

This function does not return an MBR geometry if a proper MBR cannot be constructed. Specifically:

- If the input geometry is null, the function returns a null geometry.
- If the input geometry is a point, the function returns the point.
- If the input geometry consists of points all on a straight line, the function returns a two-point line.
- If the input geometry has three dimensions but all Z dimension values are the same, the function returns a three-dimensional line.

Examples

The following example returns the minimum bounding rectangle of the `cola_d` geometry in the `COLA_MARKETS` table. (The example uses the definitions and data from [Section 2.1](#). Because `cola_d` is a circle, the minimum bounding rectangle in this case is a square.)

```
-- Return the minimum bounding rectangle of cola_d (a circle).
SELECT SDO_GEOM.SDO_MBR(c.shape, m.diminfo)
  FROM cola_markets c, user_sdo_geom_metadata m
  WHERE m.table_name = 'COLA_MARKETS' AND m.column_name = 'SHAPE'
  AND c.name = 'cola_d';

SDO_GEOM.SDO_MBR(C.SHAPE,M.DIMINFO)(SDO_GTYPE, SDO_SRID, SDO_POINT(X, Y, Z), SDO
-----
SDO_GEOMETRY(2003, NULL, NULL, SDO_ELEM_INFO_ARRAY(1, 1003, 3), SDO_ORDINATE_ARR
AY(6, 7, 10, 11))
```

Related Topics

- [SDO_GEOM.SDO_MAX_MBR_ORDINATE](#)
- [SDO_GEOM.SDO_MIN_MBR_ORDINATE](#)

SDO_GEOM.SDO_MIN_MBR_ORDINATE

Format

```
SDO_GEOM.SDO_MIN_MBR_ORDINATE(  
    geom          IN SDO_GEOMETRY,  
    ordinate_pos  IN NUMBER  
    ) RETURN NUMBER;
```

or

```
SDO_GEOM.SDO_MIN_MBR_ORDINATE(  
    geom          IN SDO_GEOMETRY,  
    dim           IN SDO_DIM_ARRAY,  
    ordinate_pos  IN NUMBER  
    ) RETURN NUMBER;
```

Description

Returns the minimum value for the specified ordinate (dimension) of the minimum bounding rectangle of a geometry object.

Parameters

geom

Geometry object.

dim

Dimensional information array corresponding to `geom`, usually selected from one of the `xxx_SDO_GEOM_METADATA` views (described in [Section 2.8](#)).

ordinate_pos

Position of the ordinate (dimension) in the definition of the geometry object: 1 for the first ordinate, 2 for the second ordinate, and so on. For example, if `geom` has X, Y ordinates, 1 identifies the X ordinate and 2 identifies the Y ordinate.

Usage Notes

None.

Examples

The following example returns the minimum X (first) ordinate value of the minimum bounding rectangle of the `cola_d` geometry in the `COLA_MARKETS` table. (The example uses the definitions and data from [Section 2.1](#). The minimum bounding rectangle of `cola_d` is returned in the example for the [SDO_GEOM.SDO_MBR](#) function.)

```
SELECT SDO_GEOM.SDO_MIN_MBR_ORDINATE(c.shape, m.diminfo, 1)  
FROM cola_markets c, user_sdo_geom_metadata m  
WHERE m.table_name = 'COLA_MARKETS' AND m.column_name = 'SHAPE'  
AND c.name = 'cola_d';
```

```
SDO_GEOM.SDO_MIN_MBR_ORDINATE(C.SHAPE,M.DIMINFO,1)
```

6**Related Topics**

- [SDO_GEOM.SDO_MAX_MBR_ORDINATE](#)
- [SDO_GEOM.SDO_MBR](#)

SDO_GEOM.SDO_POINTONSURFACE

Format

```
SDO_GEOM.SDO_POINTONSURFACE(  
    geom1 IN SDO_GEOMETRY,  
    dim1  IN SDO_DIM_ARRAY  
    ) RETURN SDO_GEOMETRY;
```

or

```
SDO_GEOM.SDO_POINTONSURFACE(  
    geom1 IN SDO_GEOMETRY,  
    tol   IN NUMBER  
    ) RETURN SDO_GEOMETRY;
```

Description

Returns a point that is guaranteed to be on the surface of a polygon geometry object.

Parameters

geom1

Polygon geometry object.

dim1

Dimensional information array corresponding to `geom1`, usually selected from one of the `xxx_SDO_GEOM_METADATA` views (described in [Section 2.8](#)).

tol

Tolerance value (see [Section 1.5.5](#)).

Usage Notes

This function returns a point geometry object representing a point that is guaranteed to be on the surface of `geom1`; however, it is not guaranteed to be an interior point. (That is, it can be on the boundary or edge of `geom1`.)

The returned point can be any point on the surface. You should not make any assumptions about where on the surface the returned point is, or about whether the point is the same or different when the function is called multiple times with the same input parameter values.

In most cases this function is less useful than the [SDO_UTIL.INTERIOR_POINT](#) function, which returns a point that is guaranteed to be an interior point.

Examples

The following example returns a geometry object that is a point on the surface of `cola_a`. (The example uses the definitions and data from [Section 2.1](#).)

```
-- Return a point on the surface of a geometry.  
SELECT SDO_GEOM.SDO_POINTONSURFACE(c.shape, m.diminfo)  
FROM cola_markets c, user_sdo_geom_metadata m  
WHERE m.table_name = 'COLA_MARKETS' AND m.column_name = 'SHAPE'
```

```
AND c.name = 'cola_a';

SDO_GEOM.SDO_POINTONSURFACE(C.SHAPE,M.DIMINFO) (SDO_GTYPE, SDO_SRID, SDO_POINT(X,
-----
SDO_GEOMETRY(2001, NULL, NULL, SDO_ELEM_INFO_ARRAY(1, 1, 1), SDO_ORDINATE_ARRAY(
1, 1))
```

Related Topics

None.

SDO_GEOM.SDO_TRIANGULATE

Format

```
SDO_GEOM.SDO_TRIANGULATE(
  geom IN SDO_GEOMETRY,
  tol   IN NUMBER
) RETURN SDO_GEOMETRY;
```

Description

Returns a geometry with triangular elements that result from Delaunay triangulation of the input geometry.

Parameters

geom

Geometry object.

tol

Tolerance value (see [Section 1.5.5](#)).

Usage Notes

This function takes all coordinates from the input geometry, uses them to compute Delaunay triangulations, and returns a geometry object, each element of which is a triangle.

An exception is raised if `geom` has fewer than three points or vertices, or consists of multiple points all in a straight line.

With geodetic data, this function is supported by approximations, as explained in [Section 6.10.3](#).

Examples

The following example returns a geometry object that consists of triangular elements (two in this case) comprising the `cola_c` polygon geometry. (The example uses the definitions and data from [Section 2.1](#).)

```
-- Return triangles comprising a specified polygon.
SELECT c.name, SDO_GEOM.SDO_TRIANGULATE(c.shape, 0.005)
  FROM cola_markets c WHERE c.name = 'cola_c';

NAME
-----
SDO_GEOM.SDO_TRIANGULATE(C.SHAPE,0.005)(SDO_GTYPE, SDO_SRID, SDO_POINT(X, Y, Z),
-----
cola_c
SDO_GEOMETRY(2007, NULL, NULL, SDO_ELEM_INFO_ARRAY(1, 1003, 1, 9, 1003, 1), SDO_
ORDINATE_ARRAY(3, 3, 6, 3, 4, 5, 3, 3, 4, 5, 6, 3, 6, 5, 4, 5))
```

Related Topics

[SDO_GEOM.SDO_ALPHA_SHAPE](#)

SDO_GEOM.SDO_UNION

Format

```
SDO_GEOM.SDO_UNION(  
    geom1 IN SDO_GEOMETRY,  
    dim1  IN SDO_DIM_ARRAY,  
    geom2 IN SDO_GEOMETRY,  
    dim2  IN SDO_DIM_ARRAY  
    ) RETURN SDO_GEOMETRY;
```

or

```
SDO_GEOM.SDO_UNION(  
    geom1 IN SDO_GEOMETRY,  
    geom2 IN SDO_GEOMETRY,  
    tol   IN NUMBER  
    ) RETURN SDO_GEOMETRY;
```

Description

Returns a geometry object that is the topological union (OR operation) of two geometry objects.

Parameters

geom1

Geometry object.

dim1

Dimensional information array corresponding to `geom1`, usually selected from one of the `xxx_SDO_GEOM_METADATA` views (described in [Section 2.8](#)).

geom2

Geometry object.

dim2

Dimensional information array corresponding to `geom2`, usually selected from one of the `xxx_SDO_GEOM_METADATA` views (described in [Section 2.8](#)).

tol

Tolerance value (see [Section 1.5.5](#)).

Usage Notes

In [Figure 24-4](#), the shaded area represents the polygon returned when `SDO_UNION` is used with a square (`geom1`) and another polygon (`geom2`).

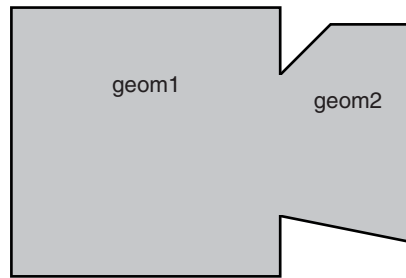
Figure 24–4 SDO_GEOM.SDO_UNION

If it is sufficient to append one geometry to another geometry without performing a topological union operation, and if both geometries are disjoint, using the [SDO_UTIL.APPEND](#) function (described in [Chapter 32](#)) is faster than using the SDO_UNION function.

An exception is raised if `geom1` and `geom2` are based on different coordinate systems.

Examples

The following example returns a geometry object that is the topological union (OR operation) of `cola_a` and `cola_c`. (The example uses the definitions and data from [Section 2.1](#).)

```
-- Return the topological union of two geometries.
SELECT SDO_GEOM.SDO_UNION(c_a.shape, m.diminfo, c_c.shape, m.diminfo)
  FROM cola_markets c_a, cola_markets c_c, user_sdo_geom_metadata m
 WHERE m.table_name = 'COLA_MARKETS' AND m.column_name = 'SHAPE'
 AND c_a.name = 'cola_a' AND c_c.name = 'cola_c';

SDO_GEOM.SDO_UNION(C_A.SHAPE,M.DIMINFO,C_C.SHAPE,M.DIMINFO) (SDO_GTYPE, SDO_SRID,
-----
SDO_GEOMETRY(2003, NULL, NULL, SDO_ELEM_INFO_ARRAY(1, 1003, 1), SDO_ORDINATE_ARR
AY(5, 5, 5, 7, 1, 7, 1, 1, 5, 1, 5, 3, 6, 3, 6, 5, 5, 5))
```

Note that in the returned polygon, the SDO_ORDINATE_ARRAY starts and ends at the same point (5, 5).

Related Topics

- [SDO_GEOM.SDO_DIFFERENCE](#)
- [SDO_GEOM.SDO_INTERSECTION](#)
- [SDO_GEOM.SDO_XOR](#)

SDO_GEOM.SDO_VOLUME

Format

```
SDO_GEOM.SDO_VOLUME(
  geom IN SDO_GEOMETRY,
  tol   IN NUMBER
  [, unit IN VARCHAR2]
) RETURN NUMBER;
```

Description

Returns the volume of a three-dimensional solid.

Parameters

geom

Geometry object.

tol

Tolerance value (see [Section 1.5.5](#)).

unit

Unit of measurement: a quoted string with `unit=` and volume unit (for example, `'unit=CUBIC_FOOT'` or `'unit=CUBIC_METER'`). For a list of volume units, enter the following query:

```
SELECT short_name FROM mdsys.sdo_units_of_measure WHERE unit_of_meas_type =
'volume';
```

See [Section 2.10](#) for more information about unit of measurement specification.

If this parameter is not specified, the unit of measurement associated with the data is assumed.

Usage Notes

This function works with any solid, including solids with holes.

This function is not supported with geodetic data.

For information about support for three-dimensional geometries, see [Section 1.11](#).

Examples

The following example returns the volume of a solid geometry object.

```
-- Return the volume of a solid geometry.
SELECT p.id, SDO_GEOM.SDO_VOLUME(p.geometry, 0.005) FROM polygons3d p
WHERE p.id = 12;
```

```

          ID SDO_GEOM.SDO_VOLUME(P.GEOMETRY,0.005)
-----
          12                                6
```

Related Topics

None.

SDO_GEOM.SDO_XOR

Format

```
SDO_GEOM.SDO_XOR(  
    geom1 IN SDO_XOR,  
    dim1  IN SDO_DIM_ARRAY,  
    geom2 IN SDO_GEOMETRY,  
    dim2  IN SDO_DIM_ARRAY  
    ) RETURN SDO_GEOMETRY;
```

or

```
SDO_GEOM.SDO_XOR(  
    geom1 IN SDO_GEOMETRY,  
    geom2 IN SDO_GEOMETRY,  
    tol   IN NUMBER  
    ) RETURN SDO_GEOMETRY;
```

Description

Returns a geometry object that is the topological symmetric difference (XOR operation) of two geometry objects.

Parameters

geom1

Geometry object.

dim1

Dimensional information array corresponding to `geom1`, usually selected from one of the `xxx_SDO_GEOM_METADATA` views (described in [Section 2.8](#)).

geom2

Geometry object.

dim2

Dimensional information array corresponding to `geom2`, usually selected from one of the `xxx_SDO_GEOM_METADATA` views (described in [Section 2.8](#)).

tol

Tolerance value (see [Section 1.5.5](#)).

Usage Notes

In [Figure 24-5](#), the shaded area represents the polygon returned when `SDO_XOR` is used with a square (`geom1`) and another polygon (`geom2`).

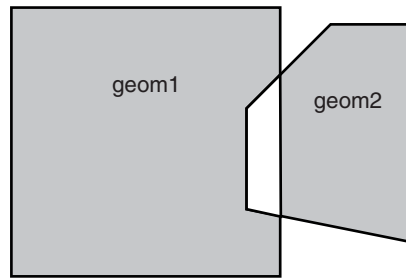
Figure 24–5 SDO_GEOM.SDO_XOR

An exception is raised if `geom1` and `geom2` are based on different coordinate systems.

Examples

The following example returns a geometry object that is the topological symmetric difference (XOR operation) of `cola_a` and `cola_c`. (The example uses the definitions and data from [Section 2.1](#).)

```
-- Return the topological symmetric difference of two geometries.
SELECT SDO_GEOM.SDO_XOR(c_a.shape, m.diminfo, c_c.shape, m.diminfo)
  FROM cola_markets c_a, cola_markets c_c, user_sdo_geom_metadata m
 WHERE m.table_name = 'COLA_MARKETS' AND m.column_name = 'SHAPE'
 AND c_a.name = 'cola_a' AND c_c.name = 'cola_c';

SDO_GEOM.SDO_XOR(C_A.SHAPE,M.DIMINFO,C_C.SHAPE,M.DIMINFO) (SDO_GTYPE, SDO_SRID, S
-----
SDO_GEOMETRY(2007, NULL, NULL, SDO_ELEM_INFO_ARRAY(1, 1003, 1, 19, 1003, 1), SDO
_ORDINATE_ARRAY(1, 7, 1, 1, 5, 1, 5, 3, 3, 3, 4, 5, 5, 5, 5, 7, 1, 7, 5, 5, 5, 3
, 6, 3, 6, 5, 5, 5))
```

Note that the returned polygon is a multipolygon (`SDO_GTYPE = 2007`), and the `SDO_ORDINATE_ARRAY` describes two polygons: one starting and ending at (1, 7) and the other starting and ending at (5, 5).

Related Topics

- [SDO_GEOM.SDO_DIFFERENCE](#)
- [SDO_GEOM.SDO_INTERSECTION](#)
- [SDO_GEOM.SDO_UNION](#)

SDO_GEOM.VALIDATE_GEOMETRY_WITH_CONTEXT

Format

```
SDO_GEOM.VALIDATE_GEOMETRY_WITH_CONTEXT(
    theGeometry IN SDO_GEOMETRY,
    theDimInfo  IN SDO_DIM_ARRAY,
    conditional  IN VARCHAR2 DEFAULT 'TRUE' ,
    flag10g     IN VARCHAR2 DEFAULT 'FALSE'
) RETURN VARCHAR2;
```

or

```
SDO_GEOM.VALIDATE_GEOMETRY_WITH_CONTEXT(
    theGeometry IN SDO_GEOMETRY,
    tolerance   IN NUMBER,
    conditional  IN VARCHAR2 DEFAULT 'TRUE' ,
    flag10g     IN VARCHAR2 DEFAULT 'FALSE'
) RETURN VARCHAR2;
```

Description

Performs a consistency check for valid geometry types and returns context information if the geometry is invalid. The function checks the representation of the geometry from the tables against the element definitions.

Parameters

theGeometry

Geometry object.

theDimInfo

Dimensional information array corresponding to *theGeometry*, usually selected from one of the xxx_SDO_GEOM_METADATA views (described in [Section 2.8](#)).

tolerance

Tolerance value (see [Section 1.5.5](#)).

conditional

Conditional flag; relevant only for a three-dimensional composite surface or composite solid. A string value of `TRUE` (the default) causes validation to fail if two outer rings are on the same plane and share an edge; a string value of `FALSE` does not cause validation to fail if two outer rings are on the same plane and share an edge.

flag10g

Oracle Database 10g compatibility flag. A string value of `TRUE` causes only validation checks specific to two-dimensional geometries to be performed, and no 3D-specific validation checks to be performed. A string value of `FALSE` (the default) performs all validation checks that are relevant for the geometry. (See the Usage Notes for more information about the `flag10g` parameter.)

Usage Notes

If the geometry is valid, this function returns TRUE. (For a user-defined geometry, that is, a geometry with an SDO_GTYPE value of 2000, this function returns the string NULL.)

If the geometry is not valid, this function returns the following:

- An Oracle error message number based on the specific reason the geometry is invalid, or FALSE if the geometry fails for some other reason
- The context of the error (the coordinate, edge, or ring that causes the geometry to be invalid). (See "[Context of Errors: Details](#)" in this section.)

This function checks for type consistency and geometry consistency.

For type consistency, the function checks for the following:

- The SDO_GTYPE is valid.
- The SDO_ETYPE values are consistent with the SDO_GTYPE value. For example, if the SDO_GTYPE is 2003, there should be at least one element of type POLYGON in the geometry.
- The SDO_ELEM_INFO_ARRAY has valid triplet values.

For geometry consistency, the function checks for the following, as appropriate for the specific geometry type:

- Polygons have at least four points, which includes the point that closes the polygon. (The last point is the same as the first.)
- Polygons are not self-crossing.
- No two vertices on a line or polygon are the same.
- Polygons are oriented correctly. (Exterior ring boundaries must be oriented counterclockwise, and interior ring boundaries must be oriented clockwise.)
- An interior polygon ring touches the exterior polygon ring at no more than one point.
- If two or more interior polygon rings are in an exterior polygon ring, the interior polygon rings touch at no more than one point.
- Line strings have at least two points.
- SDO_ETYPE 1-digit and 4-digit values are not mixed (that is, both used) in defining polygon ring elements.
- Points on an arc are not colinear (that is, are not on a straight line) and are not the same point.
- Geometries are within the specified bounds of the applicable DIMINFO column value (from the USER_SDO_GEOM_METADATA view).
- LRS geometries (see [Chapter 7](#)) have three or four dimensions and a valid measure dimension position (3 or 4, depending on the number of dimensions).

For COLLECTION type geometries, some of the preceding checks mentioned above are not performed. Specifically, interior ring checks and polygon-polygon overlap checks are not performed for polygon elements of the COLLECTION type geometry.

For multipoint geometries, this function checks for duplicate vertices with three-dimensional geometries, but not with two-dimensional geometries.

For three-dimensional geometries, this function also performs the checks described in [Section 1.11.5](#).

In checking for geometry consistency, the function considers the geometry's tolerance value in determining if lines touch or if points are the same.

If the function format with `tolerance` is used, no checking is done to validate that the geometry is within the coordinate system bounds as stored in the `DIMINFO` field of the `USER_SDO_GEOM_METADATA` view. If this check is required for your usage, use the function format with `theDimInfo`.

Setting the `flag10g` parameter value to `TRUE` causes the validation logic for Oracle Spatial Release 10.2 to be used, irrespective of the dimensionality of the geometry. This can be useful for allowing three-dimensional geometries that contain geometries in pre-Release 11.1 format to pass the validation check when they would otherwise fail. For example, a three-dimensional line is not valid if it contains circular arcs; and setting `flag10g` to `TRUE` will allow such geometries to avoid being considered invalid solely because of the circular arcs. (You should later make these geometries valid according to the criteria for the current release, such as by densifying the circular arcs.)

You can use this function in a PL/SQL procedure as an alternative to using the [SDO_GEOM.VALIDATE_LAYER_WITH_CONTEXT](#) procedure. See the Usage Notes for [SDO_GEOM.VALIDATE_LAYER_WITH_CONTEXT](#) for more information.

Context of Errors: Details

If a geometry is invalid, the result can include information about a combination of the following: coordinates, elements, rings, and edges.

- Coordinates:** A coordinate refers to a vertex in a geometry. In a two-dimensional geometry, a vertex is two numbers (X and Y, or Longitude and Latitude). In a three-dimensional geometry, a vertex is defined using three numbers; and in a four-dimensional geometry, a vertex is defined using four numbers. (You can use the [SDO_UTIL.GETVERTICES](#) function to return the coordinates in a geometry.)

If you receive a geometry validation error such as 13356 (adjacent points in a geometry are redundant), you can call the [SDO_UTIL.GETVERTICES](#) function, specifying a `rownum` stopping condition to include the coordinate one greater than the coordinate indicated with the error. The last two coordinates shown in the output are the redundant coordinates. These coordinates may be exactly the same, or they may be within the user-specified tolerance and thus are considered the same point. You can remove redundant coordinates by using the [SDO_UTIL.REMOVE_DUPLICATE_VERTICES](#) function.

- Elements:** An element is a point, a line string, or an exterior polygon with zero or more corresponding interior polygons. (That is, a polygon element includes the exterior ring and all interior rings associated with that exterior ring.) If a geometry is a multi-element geometry (for example, multiple points, lines, or polygons), the first element is element 1, the second element is element 2, and so on.
- Rings:** A ring is only used with polygon elements. Exterior rings in a polygon are considered polygon elements, and an exterior ring can include zero or more interior rings (or holes). Each interior ring has its own ring designation, but Ring 1 is associated with the exterior polygon itself. For example, Element 1, Ring 1 refers to the first exterior polygon in a geometry; Element 1, Ring 2 refers to the first interior polygon of the first exterior polygon; and Element 1, Ring 3 refers to the second interior polygon. If the geometry is a multipolygon, Element 2, Ring 1 is used to refer to the second exterior polygon. If there are interior polygons associated with it, Element 2, Ring 2 refers to the first interior polygon of the second exterior polygon.

- Edges:** An edge refers to a line segment between two coordinates. Edge 1 refers to the segment between coordinate 1 and coordinate 2, Edge 2 refers to the line segment between coordinates 2 and 3, and so on. The most common place to see edge errors when validating geometries is with self-intersecting polygons. (The Open Geospatial Consortium simple features specification does not allow a polygon to self-intersect.) In such cases, Oracle reports error 13349 (polygon boundary crosses itself), including the Element, Ring, and Edge numbers where self-intersection occurs.

If error 13351 (shared edge) is returned for an optimized rectangle that spans more than 119 degrees in longitude, some queries on this rectangle will return correct results, as explained in [Section 6.2.4](#).

Examples

The following example validates a geometry (deliberately created as invalid) named `cola_invalid_geom`.

```
-- Validate; provide context if invalid
SELECT c.name, SDO_GEOM.VALIDATE_GEOMETRY_WITH_CONTEXT(c.shape, 0.005)
       FROM cola_markets c WHERE c.name = 'cola_invalid_geom';
```

NAME

```
-----
SDO_GEOM.VALIDATE_GEOMETRY_WITH_CONTEXT(C.SHAPE,0.005)
-----
```

cola_invalid_geom

```
13349 [Element <1>] [Ring <1>][Edge <1>][Edge <3>]
```

In the output for this example, 13349 indicates the error `ORA-13349: polygon boundary crosses itself`. The first ring of the first element has edges that intersect. The edges that intersect are edge 1 (the first and second vertices) and edge 3 (the third and fourth vertices).

Related Topics

- [SDO_GEOM.VALIDATE_LAYER_WITH_CONTEXT](#)

SDO_GEOM.VALIDATE_LAYER_WITH_CONTEXT

Format

```
SDO_GEOM.VALIDATE_LAYER_WITH_CONTEXT(
    geom_table    IN VARCHAR2,
    geom_column   IN VARCHAR2,
    result_table   IN VARCHAR2
    commit_interval IN NUMBER DEFAULT -1,
    conditional    IN VARCHAR2 DEFAULT 'TRUE' ,
    flag10g       IN VARCHAR2 DEFAULT 'FALSE');
```

Description

Examines a geometry column to determine if the stored geometries follow the defined rules for geometry objects, and returns context information about any invalid geometries.

Parameters

geom_table

Spatial geometry table.

geom_column

Geometry object column to be examined.

result_table

Result table to hold the validation results. A row is added to `result_table` for each invalid geometry. If there are no invalid geometries, one or more (depending on the `commit_interval` value) rows with a result of `DONE` are added.

commit_interval

Number of geometries to validate before Spatial performs an internal commit operation and writes a row with a result of `DONE` to `result_table` (if no rows for invalid geometries have been written since the last commit operation). If `commit_interval` is not specified, no internal commit operations are performed during the validation.

The `commit_interval` option is helpful if you want to look at the contents of `result_table` while the validation is in progress.

conditional

Conditional flag; relevant only for a three-dimensional composite surface or composite solid. A string value of `TRUE` (the default) causes validation to fail if two outer rings are on the same plane and share an edge; a string value of `FALSE` does not cause validation to fail if two outer rings are on the same plane and share an edge.

flag10g

Oracle Database 10g compatibility flag. A string value of `TRUE` causes only validation checks specific to two-dimensional geometries to be performed, and no 3D-specific validation checks to be performed. A string value of `FALSE` (the default) performs all validation checks that are relevant for the geometries. (See the Usage Notes for the

[SDO_GEOM.VALIDATE_GEOMETRY_WITH_CONTEXT](#) function for more information about the `flag10g` parameter.)

Usage Notes

This procedure loads the result table with validation results.

An empty result table (`result_table` parameter) must be created before calling this procedure. The format of the result table is: (`sdo_rowid` ROWID, `result` VARCHAR2(2000)). If `result_table` is not empty, you should truncate the table before calling the procedure; otherwise, the procedure appends rows to the existing data in the table.

The result table contains one row for each invalid geometry. A row is not written if a geometry is valid, except as follows:

- If `commit_interval` is not specified (or if the `commit_interval` value is greater than the number of geometries in the layer) and no invalid geometries are found, a single row with a `RESULT` value of `DONE` is written.
- If `commit_interval` is specified and if no invalid geometries are found between an internal commit and the previous internal commit (or start of validation for the first internal commit), a single row with the primary key of the last geometry validated and a `RESULT` value of `DONE` is written. (If there have been no invalid geometries since the last internal commit operation, this row replaces the previous row that had a result of `DONE`.)

In each row for an invalid geometry, the `SDO_ROWID` column contains the ROWID value of the row containing the invalid geometry, and the `RESULT` column contains an Oracle error message number and the context of the error (the coordinate, edge, or ring that causes the geometry to be invalid). You can then look up the error message for more information about the cause of the failure.

This procedure performs the following checks on each geometry in the layer (`geom_column`):

- All type consistency and geometry consistency checks that are performed by the [SDO_GEOM.VALIDATE_GEOMETRY_WITH_CONTEXT](#) function (see the Usage Notes for that function).
- The geometry's SRID value (coordinate system) is the same as the one specified in the applicable `DIMINFO` column value (from the `USER_SDO_GEOM_METADATA` view, which is described in [Section 2.8](#)).

Examples

The following example validates the geometry objects stored in the `SHAPE` column of the `COLA_MARKETS` table. The example includes the creation of the result table. For this example, a deliberately invalid geometry was inserted into the table before the validation was performed.

```
-- Is a layer valid? (First, create the result table.)
CREATE TABLE val_results (sdo_rowid ROWID, result varchar2(1000));
-- (Next statement must be on one command line.)
CALL SDO_GEOM.VALIDATE_LAYER_WITH_CONTEXT('COLA_MARKETS', 'SHAPE', 'VAL_RESULTS');
```

Call completed.

```
SQL> SELECT * from val_results;
```

```
SDO_ROWID
```

RESULT

Rows Processed <12>

AAABXNAABAAK+YAAC

13349 [Element <1>] [Ring <1>][Edge <1>][Edge <3>]

Related Topics

- [SDO_GEOM.VALIDATE_GEOMETRY_WITH_CONTEXT](#)

SDO_GEOM.WITHIN_DISTANCE

Format

```
SDO_GEOM.WITHIN_DISTANCE(  
    geom1 IN SDO_GEOMETRY,  
    dim1  IN SDO_DIM_ARRAY,  
    dist  IN NUMBER,  
    geom2 IN SDO_GEOMETRY,  
    dim2  IN SDO_DIM_ARRAY  
    [, units IN VARCHAR2]  
    ) RETURN VARCHAR2;
```

or

```
SDO_GEOM.WITHIN_DISTANCE(  
    geom1 IN SDO_GEOMETRY,  
    dist  IN NUMBER,  
    geom2 IN SDO_GEOMETRY,  
    tol   IN NUMBER  
    [, units IN VARCHAR2]  
    ) RETURN VARCHAR2;
```

Description

Determines if two spatial objects are within some specified distance from each other.

Parameters

geom1

Geometry object.

dim1

Dimensional information array corresponding to `geom1`, usually selected from one of the `xxx_SDO_GEOM_METADATA` views (described in [Section 2.8](#)).

dist

Distance value.

geom2

Geometry object.

dim2

Dimensional information array corresponding to `geom2`, usually selected from one of the `xxx_SDO_GEOM_METADATA` views (described in [Section 2.8](#)).

tol

Tolerance value (see [Section 1.5.5](#)).

units

Unit of measurement: a quoted string with `unit=` and an `SDO_UNIT` value from the `MDSYS.SDO_AREA_UNITS` table (for example, `'unit=KM'`). See [Section 2.10](#) for more information about unit of measurement specification.

If this parameter is not specified, the unit of measurement associated with the data is assumed. For geodetic data, the default unit of measurement is meters.

Usage Notes

For better performance, use the [SDO_WITHIN_DISTANCE](#) operator (described in [Chapter 19](#)) instead of the `SDO_GEOM.WITHIN_DISTANCE` function. For more information about performance considerations with operators and functions, see [Section 1.9](#).

This function returns `TRUE` for object pairs that are within the specified distance, and `FALSE` otherwise.

The distance between two extended objects (for example, nonpoint objects such as lines and polygons) is defined as the minimum distance between these two objects. Thus the distance between two adjacent polygons is zero.

An exception is raised if `geom1` and `geom2` are based on different coordinate systems.

Examples

The following example checks if `cola_b` and `cola_d` are within 1 unit apart at the shortest distance between them. (The example uses the definitions and data from [Section 2.1](#).)

```
-- Are two geometries within 1 unit of distance apart?
SELECT SDO_GEOM.WITHIN_DISTANCE(c_b.shape, m.diminfo, 1,
    c_d.shape, m.diminfo)
    FROM cola_markets c_b, cola_markets c_d, user_sdo_geom_metadata m
    WHERE m.table_name = 'COLA_MARKETS' AND m.column_name = 'SHAPE'
    AND c_b.name = 'cola_b' AND c_d.name = 'cola_d';
```

```
SDO_GEOM.WITHIN_DISTANCE(C_B.SHAPE,M.DIMINFO,1,C_D.SHAPE,M.DIMINFO)
```

```
-----
TRUE
```

Related Topics

- [SDO_GEOM.SDO_DISTANCE](#)

SDO_LRS Package (Linear Referencing System)

The MDSYS.SDO_LRS package contains subprograms that create, modify, query, and convert linear referencing elements. These subprograms do not change the state of the database. Most LRS subprograms are functions.

To use the subprograms in this chapter, you must understand the linear referencing system (LRS) concepts and techniques described in [Chapter 7](#).

[Table 25–1](#) lists subprograms related to creating and editing geometric segments.

Table 25–1 Subprograms for Creating and Editing Geometric Segments

Subprogram	Description
SDO_LRS.DEFINE_GEOM_SEGMENT	Defines a geometric segment.
SDO_LRS.REDEFINE_GEOM_SEGMENT	Populates the measures of all shape points of a geometric segment based on the start and end measures, overriding any previously assigned measures between the start point and end point.
SDO_LRS.CLIP_GEOM_SEGMENT	Clips a geometric segment (synonym of SDO_LRS.DYNAMIC_SEGMENT).
SDO_LRS.DYNAMIC_SEGMENT	Clips a geometric segment (synonym of SDO_LRS.CLIP_GEOM_SEGMENT).
SDO_LRS.CONCATENATE_GEOM_SEGMENTS	Concatenates two geometric segments into one segment.
SDO_LRS.LRS_INTERSECTION	Returns an LRS geometry object that is the topological intersection (AND operation) of two geometry objects where one or both are LRS geometries.
SDO_LRS.OFFSET_GEOM_SEGMENT	Returns the geometric segment at a specified offset from a geometric segment.
SDO_LRS.SPLIT_GEOM_SEGMENT	Splits a geometric segment into two segments.
SDO_LRS.RESET_MEASURE	Sets all measures of a geometric segment, including the start and end measures, to null values, overriding any previously assigned measures.
SDO_LRS.SCALE_GEOM_SEGMENT	Returns the geometry object resulting from a measure scaling operation on a geometric segment.
SDO_LRS.SET_PT_MEASURE	Sets the measure value of a specified point.

Table 25–1 (Cont.) Subprograms for Creating and Editing Geometric Segments

Subprogram	Description
SDO_LRS.REVERSE_MEASURE	Returns a new geometric segment by reversing the measure values, but not the direction, of the original geometric segment.
SDO_LRS.TRANSLATE_MEASURE	Returns a new geometric segment by translating the original geometric segment (that is, shifting the start and end measures by a specified value).
SDO_LRS.REVERSE_GEOMETRY	Returns a new geometric segment by reversing the measure values and the direction of the original geometric segment.

Table 25–2 lists subprograms related to querying geometric segments.

Table 25–2 Subprograms for Querying and Validating Geometric Segments

Subprogram	Description
SDO_LRS.VALID_GEOM_SEGMENT	Checks if a geometric segment is valid.
SDO_LRS.VALID_LRS_PT	Checks if an LRS point is valid.
SDO_LRS.VALID_MEASURE	Checks if a measure falls within the measure range of a geometric segment.
SDO_LRS.CONNECTED_GEOM_SEGMENTS	Checks if two geometric segments are spatially connected.
SDO_LRS.GEOM_SEGMENT_LENGTH	Returns the length of a geometric segment.
SDO_LRS.GEOM_SEGMENT_START_PT	Returns the start point of a geometric segment.
SDO_LRS.GEOM_SEGMENT_END_PT	Returns the end point of a geometric segment.
SDO_LRS.GEOM_SEGMENT_START_MEASURE	Returns the start measure of a geometric segment.
SDO_LRS.GEOM_SEGMENT_END_MEASURE	Returns the end measure of a geometric segment.
SDO_LRS.GET_MEASURE	Returns the measure of an LRS point.
SDO_LRS.GET_NEXT_SHAPE_PT	Returns the next shape point on a geometric segment after a specified measure value or LRS point.
SDO_LRS.GET_NEXT_SHAPE_PT_MEASURE	Returns the measure value of the next shape point on a geometric segment after a specified measure value or LRS point.
SDO_LRS.GET_PREV_SHAPE_PT	Returns the previous shape point on a geometric segment before a specified measure value or LRS point.
SDO_LRS.GET_PREV_SHAPE_PT_MEASURE	Returns the measure value of the previous shape point on a geometric segment before a specified measure value or LRS point.
SDO_LRS.IS_GEOM_SEGMENT_DEFINED	Checks if an LRS segment is defined correctly.
SDO_LRS.IS_MEASURE DECREASING	Checks if the measure values along an LRS segment are decreasing (that is, descending in numerical value).

Table 25–2 (Cont.) Subprograms for Querying and Validating Geometric Segments

Subprogram	Description
SDO_LRS.IS_MEASURE_INCREASING	Checks if the measure values along an LRS segment are increasing (that is, ascending in numerical value).
SDO_LRS.IS_SHAPE_PT_MEASURE	Checks if a specified measure value is associated with a shape point on a geometric segment.
SDO_LRS.MEASURE_RANGE	Returns the measure range of a geometric segment, that is, the difference between the start measure and end measure.
SDO_LRS.MEASURE_TO_PERCENTAGE	Returns the percentage (0 to 100) that a specified measure is of the measure range of a geometric segment.
SDO_LRS.PERCENTAGE_TO_MEASURE	Returns the measure value of a specified percentage (0 to 100) of the measure range of a geometric segment.
SDO_LRS.LOCATE_PT	Returns the point located at a specified distance from the start of a geometric segment.
SDO_LRS.PROJECT_PT	Returns the projection point of a specified point. The projection point is on the geometric segment.
SDO_LRS.FIND_LRS_DIM_POS	Returns the position of the measure dimension within the SDO_DIM_ARRAY structure for a specified SDO_GEOMETRY column.
SDO_LRS.FIND_MEASURE	Returns the measure of the closest point on a segment to a specified projection point.
SDO_LRS.FIND_OFFSET	Returns the signed offset (shortest distance) from a point to a geometric segment.
SDO_LRS.VALIDATE_LRS_GEOMETRY	Checks if an LRS geometry is valid.

Table 25–3 lists subprograms related to converting geometric segments.

Table 25–3 Subprograms for Converting Geometric Segments

Subprogram	Description
SDO_LRS.CONVERT_TO_LRS_DIM_ARRAY	Converts a standard dimensional array to an LRS dimensional array by creating a measure dimension.
SDO_LRS.CONVERT_TO_LRS_GEOM	Converts a standard SDO_GEOMETRY line string to an LRS geometric segment by adding measure information.
SDO_LRS.CONVERT_TO_LRS_LAYER	Converts all geometry objects in a column of type SDO_GEOMETRY from standard line string geometries without measure information to LRS geometric segments with measure information, and updates the metadata.
SDO_LRS.CONVERT_TO_STD_DIM_ARRAY	Converts an LRS dimensional array to a standard dimensional array by removing the measure dimension.
SDO_LRS.CONVERT_TO_STD_GEOM	Converts an LRS geometric segment to a standard SDO_GEOMETRY line string by removing measure information.

Table 25–3 (Cont.) Subprograms for Converting Geometric Segments

Subprogram	Description
SDO_LRS.CONVERT_TO_STD_LAYER	Converts all geometry objects in a column of type SDO_GEOMETRY from LRS geometric segments with measure information to standard line string geometries without measure information, and updates the metadata.

For more information about conversion subprograms, see [Section 7.5.10](#).

The rest of this chapter provides reference information on the subprograms, listed in alphabetical order.

SDO_LRS.CLIP_GEOM_SEGMENT

Format

```
SDO_LRS.CLIP_GEOM_SEGMENT(
    geom_segment IN SDO_GEOMETRY,
    start_measure IN NUMBER,
    end_measure   IN NUMBER,
    tolerance     IN NUMBER DEFAULT 1.0e-8
) RETURN SDO_GEOMETRY;
```

or

```
SDO_LRS.CLIP_GEOM_SEGMENT(
    geom_segment IN SDO_GEOMETRY,
    dim_array    IN SDO_DIM_ARRAY,
    start_measure IN NUMBER,
    end_measure   IN NUMBER
) RETURN SDO_GEOMETRY;
```

Description

Returns the geometry object resulting from a clip operation on a geometric segment.

Note: `SDO_LRS.CLIP_GEOM_SEGMENT` and `SDO_LRS.DYNAMIC_SEGMENT` are synonyms: both functions have the same parameters, behavior, and return value.

Parameters

geom_segment

Cartographic representation of a linear feature.

dim_array

Dimensional information array corresponding to `geom_segment`, usually selected from one of the `xxx_SDO_GEOM_METADATA` views (described in [Section 2.8](#)).

start_measure

Start measure of the geometric segment.

end_measure

End measure of the geometric segment.

tolerance

Tolerance value (see [Section 1.5.5](#) and [Section 7.6](#)). The default value is 0.00000001.

Usage Notes

An exception is raised if `geom_segment`, `start_measure`, or `end_measure` is invalid.

`start_measure` and `end_measure` can be any points on the geometric segment. They do not have to be in any specific order. For example, `start_measure` and `end_measure` can be 5 and 10, respectively, or 10 and 5, respectively.

The direction and measures of the resulting geometric segment are preserved (that is, they reflect the original segment).

The `_3D` format of this function (`SDO_LRS.CLIP_GEOM_SEGMENT_3D`) is available. For information about `_3D` formats of LRS functions, see [Section 7.4](#).

For more information about clipping geometric segments, see [Section 7.5.3](#).

Examples

The following example clips the geometric segment representing Route 1, returning the segment from measures 5 through 10. This segment might represent a construction zone. (This example uses the definitions from the example in [Section 7.7](#).)

```
SELECT SDO_LRS.CLIP_GEOM_SEGMENT(route_geometry, 5, 10)
       FROM lrs_routes WHERE route_id = 1;
```

```
SDO_LRS.CLIP_GEOM_SEGMENT(ROUTE_GEOMETRY,5,10) (SDO_GTYPE, SDO_SRID, SDO_POINT(X,
-----
SDO_GEOMETRY(3302, NULL, NULL, SDO_ELEM_INFO_ARRAY(1, 2, 1), SDO_ORDINATE_ARRAY(
5, 4, 5, 8, 4, 8, 10, 4, 10))
```

SDO_LRS.CONCATENATE_GEOM_SEGMENTS

Format

```
SDO_LRS.CONCATENATE_GEOM_SEGMENTS(
    geom_segment_1 IN SDO_GEOMETRY,
    geom_segment_2 IN SDO_GEOMETRY,
    tolerance      IN NUMBER DEFAULT 1.0e-8
) RETURN SDO_GEOMETRY;
```

or

```
SDO_LRS.CONCATENATE_GEOM_SEGMENTS(
    geom_segment_1 IN SDO_GEOMETRY,
    dim_array_1    IN SDO_DIM_ARRAY,
    geom_segment_2 IN SDO_GEOMETRY,
    dim_array_2    IN SDO_DIM_ARRAY
) RETURN SDO_GEOMETRY;
```

Description

Returns the geometry object resulting from the concatenation of two geometric segments.

Parameters

geom_segment_1

First geometric segment to be concatenated.

dim_array_1

Dimensional information array corresponding to `geom_segment_1`, usually selected from one of the `xxx_SDO_GEOM_METADATA` views (described in [Section 2.8](#)).

geom_segment_2

Second geometric segment to be concatenated.

dim_array_2

Dimensional information array corresponding to `geom_segment_2`, usually selected from one of the `xxx_SDO_GEOM_METADATA` views (described in [Section 2.8](#)).

tolerance

Tolerance value (see [Section 1.5.5](#) and [Section 7.6](#)). The default value is 0.00000001.

Usage Notes

An exception is raised if `geom_segment_1` or `geom_segment_2` has an invalid geometry type or dimensionality, or if `geom_segment_1` and `geom_segment_2` are based on different coordinate systems.

The direction of the first geometric segment is preserved, and all measures of the second segment are shifted so that its start measure is the same as the end measure of the first segment.

The geometry type of `geom_segment_1` and `geom_segment_2` must be line or multiline. Neither can be a polygon.

The `_3D` format of this function (`SDO_LRS.CONCATENATE_GEOM_SEGMENTS_3D`) is available. For information about `_3D` formats of LRS functions, see [Section 7.4](#).

For more information about concatenating geometric segments, see [Section 7.5.5](#).

Examples

The following example defines the geometric segment, splits it into two segments, then concatenates those segments. (This example uses the definitions from the example in [Section 7.7](#). The definitions of `result_geom_1`, `result_geom_2`, and `result_geom_3` are displayed in [Example 7-3](#).)

```
DECLARE
geom_segment SDO_GEOMETRY;
line_string SDO_GEOMETRY;
dim_array SDO_DIM_ARRAY;
result_geom_1 SDO_GEOMETRY;
result_geom_2 SDO_GEOMETRY;
result_geom_3 SDO_GEOMETRY;

BEGIN

SELECT a.route_geometry into geom_segment FROM lrs_routes a
  WHERE a.route_name = 'Route1';
SELECT m.diminfo into dim_array from
  user_sdo_geom_metadata m
  WHERE m.table_name = 'LRS_ROUTES' AND m.column_name = 'ROUTE_GEOMETRY';

-- Define the LRS segment for Route1.
SDO_LRS.DEFINE_GEOM_SEGMENT (geom_segment,
  dim_array,
  0,    -- Zero starting measure: LRS segment starts at start of route.
  27); -- End of LRS segment is at measure 27.

SELECT a.route_geometry INTO line_string FROM lrs_routes a
  WHERE a.route_name = 'Route1';

-- Split Route1 into two segments.
SDO_LRS.SPLIT_GEOM_SEGMENT(line_string,dim_array,5,result_geom_1,result_geom_2);

-- Concatenate the segments that were just split.
result_geom_3 := SDO_LRS.CONCATENATE_GEOM_SEGMENTS(result_geom_1, dim_array,
result_geom_2, dim_array);

-- Insert geometries into table, to display later.
INSERT INTO lrs_routes VALUES(
  11,
  'result_geom_1',
  result_geom_1
);
INSERT INTO lrs_routes VALUES(
  12,
  'result_geom_2',
  result_geom_2
);
INSERT INTO lrs_routes VALUES(
  13,
  'result_geom_3',
```



```
    result_geom_3  
);  
  
END;  
/
```

SDO_LRS.CONNECTED_GEOM_SEGMENTS

Format

```
SDO_LRS.CONNECTED_GEOM_SEGMENTS(  
  geom_segment_1 IN SDO_GEOMETRY,  
  geom_segment_2 IN SDO_GEOMETRY,  
  tolerance      IN NUMBER DEFAULT 1.0e-8  
) RETURN VARCHAR2;
```

or

```
SDO_LRS.CONNECTED_GEOM_SEGMENTS(  
  geom_segment_1 IN SDO_GEOMETRY,  
  dim_array_1    IN SDO_DIM_ARRAY,  
  geom_segment_2 IN SDO_GEOMETRY,  
  dim_array_2    IN SDO_DIM_ARRAY  
) RETURN VARCHAR2;
```

Description

Checks if two geometric segments are spatially connected.

Parameters

geom_segment_1

First of two geometric segments to be checked.

dim_array_1

Dimensional information array corresponding to `geom_segment_1`, usually selected from one of the `xxx_SDO_GEOM_METADATA` views (described in [Section 2.8](#)).

geom_segment_2

Second of two geometric segments to be checked.

dim_array_2

Dimensional information array corresponding to `geom_segment_2`, usually selected from one of the `xxx_SDO_GEOM_METADATA` views (described in [Section 2.8](#)).

tolerance

Tolerance value (see [Section 1.5.5](#) and [Section 7.6](#)). The default value is 0.00000001.

Usage Notes

This function returns TRUE if the geometric segments are spatially connected and FALSE if the geometric segments are not spatially connected.

An exception is raised if `geom_segment_1` or `geom_segment_2` has an invalid geometry type or dimensionality, or if `geom_segment_1` and `geom_segment_2` are based on different coordinate systems.

The `_3D` format of this function (`SDO_LRS.CONNECTED_GEOM_SEGMENTS_3D`) is available. For information about `_3D` formats of LRS functions, see [Section 7.4](#).

Examples

The following example checks if two geometric segments (results of a previous split operation) are spatially connected.

```
-- Are result_geom_1 and result_geom2 connected?
SELECT  SDO_LRS.CONNECTED_GEOM_SEGMENTS(a.route_geometry,
      b.route_geometry, 0.005)
  FROM lrs_routes a, lrs_routes b
  WHERE a.route_id = 11 AND b.route_id = 12;

SDO_LRS.CONNECTED_GEOM_SEGMENTS(A.ROUTE_GEOMETRY,B.ROUTE_GEOMETRY,0.005)
-----
TRUE
```

SDO_LRS.CONVERT_TO_LRS_DIM_ARRAY

Format

```
SDO_LRS.CONVERT_TO_LRS_DIM_ARRAY(  
    dim_array      IN SDO_DIM_ARRAY  
    [, lower_bound IN NUMBER,  
    upper_bound   IN NUMBER,  
    tolerance      IN NUMBER]  
    ) RETURN SDO_DIM_ARRAY;
```

or

```
SDO_LRS.CONVERT_TO_LRS_DIM_ARRAY(  
    dim_array      IN SDO_DIM_ARRAY,  
    dim_name       IN VARCHAR2  
    [, lower_bound IN NUMBER,  
    upper_bound   IN NUMBER,  
    tolerance      IN NUMBER]  
    ) RETURN SDO_DIM_ARRAY;
```

or

```
SDO_LRS.CONVERT_TO_LRS_DIM_ARRAY(  
    dim_array      IN SDO_DIM_ARRAY,  
    dim_name       IN VARCHAR2,  
    dim_pos        IN INTEGER  
    [, lower_bound IN NUMBER,  
    upper_bound   IN NUMBER,  
    tolerance      IN NUMBER]  
    ) RETURN SDO_DIM_ARRAY;
```

Description

Converts a standard dimensional array to an LRS dimensional array by creating a measure dimension.

Parameters

dim_array

Dimensional information array corresponding to the layer (column of geometries) to be converted, usually selected from one of the xxx_SDO_GEOM_METADATA views (described in [Section 2.8](#)).

dim_name

Name of the measure dimension (M, if not otherwise specified).

dim_pos

Position of the measure dimension (the last SDO_DIM_ELEMENT object position in the SDO_DIM_ARRAY, if not otherwise specified).

lower_bound

Lower bound (SDO_LB value in the SDO_DIM_ELEMENT definition) of the ordinate in the measure dimension.

upper_bound

Upper bound (SDO_UB value in the SDO_DIM_ELEMENT definition) of the ordinate in the measure dimension.

tolerance

Tolerance value (see [Section 1.5.5](#) and [Section 7.6](#)). The default value is 0.00000001.

Usage Notes

This function converts a standard dimensional array to an LRS dimensional array by creating a measure dimension. Specifically, it adds an SDO_DIM_ELEMENT object at the end of the current SDO_DIM_ELEMENT objects in the SDO_DIM_ARRAY for the dimensional array (unless another `dim_pos` is specified), and sets the SDO_DIMNAME value in this added SDO_DIM_ELEMENT to M (unless another `dim_name` is specified). It sets the other values in the added SDO_DIM_ELEMENT according to the values of the `upper_bound`, `lower_bound`, and `tolerance` parameter values.

If `dim_array` already contains dimensional information, the `dim_array` is returned.

The `_3D` format of this function (`SDO_LRS.CONVERT_TO_LRS_DIM_ARRAY_3D`) is available. For information about `_3D` formats of LRS functions, see [Section 7.4](#).

For more information about conversion functions, see [Section 7.5.10](#).

Examples

The following example converts the dimensional array for the LRS_ROUTES table to LRS format. (This example uses the definitions from the example in [Section 7.7](#).)

```
SELECT SDO_LRS.CONVERT_TO_LRS_DIM_ARRAY(m.diminfo)
   FROM user_sdo_geom_metadata m
   WHERE m.table_name = 'LRS_ROUTES' AND m.column_name = 'ROUTE_GEOMETRY';

SDO_LRS.CONVERT_TO_LRS_DIM_ARRAY(M.DIMINFO) (SDO_DIMNAME, SDO_LB, SDO_UB, SDO_TOL
-----
SDO_DIM_ARRAY(SDO_DIM_ELEMENT('X', 0, 20, .005), SDO_DIM_ELEMENT('Y', 0, 20, .00
5), SDO_DIM_ELEMENT('M', 0, 20, .005))
```

SDO_LRS.CONVERT_TO_LRS_GEOM

Format

```
SDO_LRS.CONVERT_TO_LRS_GEOM(  
    standard_geom IN SDO_GEOMETRY  
    [, start_measure IN NUMBER,  
    end_measure IN NUMBER]  
    ) RETURN SDO_GEOMETRY;
```

or

```
SDO_LRS.CONVERT_TO_LRS_GEOM(  
    standard_geom IN SDO_GEOMETRY,  
    dim_array IN SDO_DIM_ARRAY  
    [, start_measure IN NUMBER,  
    end_measure IN NUMBER]  
    ) RETURN SDO_GEOMETRY;
```

or

```
SDO_LRS.CONVERT_TO_LRS_GEOM(  
    standard_geom IN SDO_GEOMETRY,  
    m_pos IN INTEGER  
    [, start_measure IN NUMBER,  
    end_measure IN NUMBER]  
    ) RETURN SDO_GEOMETRY;
```

Description

Converts a standard SDO_GEOMETRY line string to an LRS geometric segment by adding measure information.

Parameters

standard_geom

Line string geometry that does not contain measure information.

dim_array

Dimensional information array corresponding to `standard_geom`, usually selected from one of the `xxx_SDO_GEOM_METADATA` views (described in [Section 2.8](#)).

m_pos

Position of the measure dimension. If specified, must be 3 or 4. By default, the measure dimension is the last dimension in the SDO_DIM_ARRAY.

start_measure

Distance measured from the start point of a geometric segment to the start point of the linear feature. The default is 0.

end_measure

Distance measured from the end point of a geometric segment to the start point of the linear feature. The default is the cartographic length (for example, 75 if the cartographic length is 75 and the unit of measure is miles).

Usage Notes

This function returns an LRS geometric segment with measure information, with measure information provided for all shape points.

An exception is raised if `standard_geom` has an invalid geometry type or dimensionality, if `m_pos` is less than 3 or greater than 4, or if `start_measure` or `end_measure` is out of range.

The `_3D` format of this function (`SDO_LRS.CONVERT_TO_LRS_GEOM_3D`) is available; however, the `m_pos` parameter is not available for `SDO_LRS.CONVERT_TO_LRS_GEOM_3D`. For information about `_3D` formats of LRS functions, see [Section 7.4](#).

For more information about conversion functions, see [Section 7.5.10](#).

Examples

The following example converts the geometric segment representing Route 1 to LRS format. (This example uses the definitions from the example in [Section 7.7](#).)

```
SELECT SDO_LRS.CONVERT_TO_LRS_GEOM(a.route_geometry, m.diminfo)
   FROM lrs_routes a, user_sdo_geom_metadata m
   WHERE m.table_name = 'LRS_ROUTES' AND m.column_name = 'ROUTE_GEOMETRY'
      AND a.route_id = 1;

SDO_LRS.CONVERT_TO_LRS_GEOM(A.ROUTE_GEOMETRY,M.DIMINFO) (SDO_GTYPE, SDO_SRID, SDO
-----
SDO_GEOMETRY(3002, NULL, NULL, SDO_ELEM_INFO_ARRAY(1, 2, 1), SDO_ORDINATE_ARRAY(
2, 2, 0, 2, 4, 2, 8, 4, 8, 12, 4, 12, 12, 10, NULL, 8, 10, 22, 5, 14, 27))
```

SDO_LRS.CONVERT_TO_LRS_LAYER

Format

```
SDO_LRS.CONVERT_TO_LRS_LAYER(  
    table_name    IN VARCHAR2,  
    column_name   IN VARCHAR2  
    [, lower_bound IN NUMBER,  
    upper_bound   IN NUMBER,  
    tolerance     IN NUMBER]  
    ) RETURN VARCHAR2;
```

or

```
SDO_LRS.CONVERT_TO_LRS_LAYER(  
    table_name    IN VARCHAR2,  
    column_name   IN VARCHAR2,  
    dim_name      IN VARCHAR2,  
    dim_pos       IN INTEGER  
    [, lower_bound IN NUMBER,  
    upper_bound   IN NUMBER,  
    tolerance     IN NUMBER]  
    ) RETURN VARCHAR2;
```

Description

Converts all geometry objects in a column of type SDO_GEOMETRY (that is, converts a layer) from standard line string geometries without measure information to LRS geometric segments with measure information, and updates the metadata in the USER_SDO_GEOM_METADATA view.

Parameters

table_name

Table containing the column with the SDO_GEOMETRY objects.

column_name

Column in `table_name` containing the SDO_GEOMETRY objects.

dim_name

Name of the measure dimension. If this parameter is null, M is assumed.

dim_pos

Position of the measure dimension within the SDO_DIM_ARRAY structure for the specified SDO_GEOMETRY column. If this parameter is null, the number corresponding to the last position is assumed.

lower_bound

Lower bound (SDO_LB value in the SDO_DIM_ELEMENT definition) of the ordinate in the measure dimension.

upper_bound

Upper bound (SDO_UB value in the SDO_DIM_ELEMENT definition) of the ordinate in the measure dimension.

tolerance

Tolerance value (see [Section 1.5.5](#) and [Section 7.6](#)). The default value is 0.00000001.

Usage Notes

This function returns TRUE if the conversion was successful or if the layer already contains measure information, and the function returns an exception if the conversion was not successful.

An exception is raised if the existing dimensional information for the table is invalid.

The measure values are assigned based on a start measure of zero and an end measure of the cartographic length.

If a spatial index already exists on `column_name`, you must delete (drop) the index before converting the layer and create a new index after converting the layer. For information about deleting and creating indexes, see the [DROP INDEX](#) and [CREATE INDEX](#) statements in [Chapter 18](#).

The `_3D` format of this function (SDO_LRS.CONVERT_TO_LRS_LAYER_3D) is available. For information about `_3D` formats of LRS functions, see [Section 7.4](#).

For more information about conversion functions, see [Section 7.5.10](#).

Examples

The following example converts the geometric segments in the ROUTE_GEOMETRY column of the LRS_ROUTES table to LRS format. (This example uses the definitions from the example in [Section 7.7](#).) The SELECT statement shows that dimensional information has been added (that is, SDO_DIM_ELEMENT('M', NULL, NULL, NULL) is included in the definition).

```
BEGIN
  IF (SDO_LRS.CONVERT_TO_LRS_LAYER('LRS_ROUTES', 'ROUTE_GEOMETRY') = 'TRUE')
    THEN
      DBMS_OUTPUT.PUT_LINE('Conversion from STD_LAYER to LRS_LAYER succeeded.');
```

```
    ELSE
      DBMS_OUTPUT.PUT_LINE('Conversion from STD_LAYER to LRS_LAYER failed.');
```

```
  END IF;
END;
```

```
.
```

```
/
```

```
Conversion from STD_LAYER to LRS_LAYER succeeded.
```

PL/SQL procedure successfully completed.

```
SQL> SELECT diminfo FROM user_sdo_geom_metadata WHERE table_name = 'LRS_ROUTES'
AND column_name = 'ROUTE_GEOMETRY';
```

```
DIMINFO(SDO_DIMNAME, SDO_LB, SDO_UB, SDO_TOLERANCE)
```

```
-----
SDO_DIM_ARRAY(SDO_DIM_ELEMENT('X', 0, 20, .005), SDO_DIM_ELEMENT('Y', 0, 20, .005), SDO_DIM_ELEMENT('M', NULL, NULL, NULL))
```

SDO_LRS.CONVERT_TO_STD_DIM_ARRAY

Format

```
SDO_LRS.CONVERT_TO_STD_DIM_ARRAY(
    dim_array IN SDO_DIM_ARRAY
    [, m_pos   IN INTEGER]
    ) RETURN SDO_DIM_ARRAY;
```

Description

Converts an LRS dimensional array to a standard dimensional array by removing the measure dimension.

Parameters

dim_array

Dimensional information array corresponding to the layer (column of geometries) to be converted, usually selected from one of the xxx_SDO_GEOM_METADATA views (described in [Section 2.8](#)).

m_pos

Position of the measure dimension. If specified, must be 3 or 4. By default, the measure dimension is the last dimension in the SDO_DIM_ARRAY.

Usage Notes

This function converts an LRS dimensional array to a standard dimensional array by removing the measure dimension. Specifically, it removes the SDO_DIM_ELEMENT object at the end of the current SDO_DIM_ELEMENT objects in the SDO_DIM_ARRAY for the dim_array.

An exception is raised if m_pos is invalid (less than 3 or greater than 4).

If dim_array is already a standard dimensional array (that is, does not contain dimensional information), the dim_array is returned.

The *_3D* format of this function (SDO_LRS.CONVERT_TO_STD_DIM_ARRAY_3D) is available. For information about *_3D* formats of LRS functions, see [Section 7.4](#).

For more information about conversion functions, see [Section 7.5.10](#).

Examples

The following example converts the dimensional array for the LRS_ROUTES table to standard format. (This example uses the definitions from the example in [Section 7.7](#).)

```
SELECT SDO_LRS.CONVERT_TO_STD_DIM_ARRAY(m.diminfo)
       FROM user_sdo_geom_metadata m
       WHERE m.table_name = 'LRS_ROUTES' AND m.column_name = 'ROUTE_GEOMETRY';

SDO_LRS.CONVERT_TO_STD_DIM_ARRAY(M.DIMINFO) (SDO_DIMNAME, SDO_LB, SDO_UB, SDO_TOL
-----
SDO_DIM_ARRAY(SDO_DIM_ELEMENT('X', 0, 20, .005), SDO_DIM_ELEMENT('Y', 0, 20, .00
5))
```

SDO_LRS.CONVERT_TO_STD_GEOM

Format

```
SDO_LRS.CONVERT_TO_STD_GEOM(
  lrs_geom IN SDO_GEOMETRY
  [, dim_array IN SDO_DIM_ARRAY]
) RETURN SDO_GEOMETRY;
```

Description

Converts an LRS geometric segment to a standard SDO_GEOMETRY line string by removing measure information.

Parameters

lrs_geom

LRS geometry that contains measure information.

dim_array

Dimensional information array corresponding to `lrs_geom`, usually selected from one of the `xxx_SDO_GEOM_METADATA` views (described in [Section 2.8](#)).

Usage Notes

This function returns an SDO_GEOMETRY object in which all measure information is removed.

The `_3D` format of this function (`SDO_LRS.CONVERT_TO_STD_GEOM_3D`) is available. For information about `_3D` formats of LRS functions, see [Section 7.4](#).

For more information about conversion functions, see [Section 7.5.10](#).

Examples

The following example converts the geometric segment representing Route 1 to standard format. (This example uses the definitions from the example in [Section 7.7](#).)

```
SELECT SDO_LRS.CONVERT_TO_STD_GEOM(a.route_geometry, m.diminfo)
  FROM lrs_routes a, user_sdo_geom_metadata m
  WHERE m.table_name = 'LRS_ROUTES' AND m.column_name = 'ROUTE_GEOMETRY'
        AND a.route_id = 1;

SDO_LRS.CONVERT_TO_STD_GEOM(A.ROUTE_GEOMETRY,M.DIMINFO) (SDO_GTYPE, SDO_SRID, SDO
-----
SDO_GEOMETRY(2002, NULL, NULL, SDO_ELEM_INFO_ARRAY(1, 2, 1), SDO_ORDINATE_ARRAY(
2, 2, 2, 4, 8, 4, 12, 4, 12, 10, 8, 10, 5, 14))
```

SDO_LRS.CONVERT_TO_STD_LAYER

Format

```
SDO_LRS.CONVERT_TO_STD_LAYER(  
    table_name    IN VARCHAR2,  
    column_name   IN VARCHAR2  
    ) RETURN VARCHAR2;
```

Description

Converts all geometry objects in a column of type SDO_GEOMETRY (that is, converts a layer) from LRS geometric segments with measure information to standard line string geometries without measure information, and updates the metadata in the USER_SDO_GEOM_METADATA view.

Parameters

table_name

Table containing the column with the SDO_GEOMETRY objects.

column_name

Column in `table_name` containing the SDO_GEOMETRY objects.

Usage Notes

This function returns TRUE if the conversion was successful or if the layer already is a standard layer (that is, contains geometries without measure information), and the function returns an exception if the conversion was not successful.

If a spatial index already exists on `column_name`, you must delete (drop) the index before converting the layer and create a new index after converting the layer. For information about deleting and creating indexes, see the [DROP INDEX](#) and [CREATE INDEX](#) statements in [Chapter 18](#).

The `_3D` format of this function (`SDO_LRS.CONVERT_TO_STD_LAYER_3D`) is available. For information about `_3D` formats of LRS functions, see [Section 7.4](#).

For more information about conversion functions, see [Section 7.5.10](#).

Examples

The following example converts the geometric segments in the ROUTE_GEOMETRY column of the LRS_ROUTES table to standard format. (This example uses the definitions from the example in [Section 7.7](#).) The SELECT statement shows that dimensional information has been removed (that is, no SDO_DIM_ELEMENT('M', NULL, NULL, NULL) is included in the definition).

```
BEGIN  
    IF (SDO_LRS.CONVERT_TO_STD_LAYER('LRS_ROUTES', 'ROUTE_GEOMETRY') = 'TRUE')  
    THEN  
        DBMS_OUTPUT.PUT_LINE('Conversion from LRS_LAYER to STD_LAYER succeeded.');    ELSE  
        DBMS_OUTPUT.PUT_LINE('Conversion from LRS_LAYER to STD_LAYER failed.');    END IF;  
END;
```

```
.  
/  
Conversion from LRS_LAYER to STD_LAYER succeeded.  
  
PL/SQL procedure successfully completed.  
  
SELECT diminfo FROM user_sdo_geom_metadata  
  WHERE table_name = 'LRS_ROUTES' AND column_name = 'ROUTE_GEOMETRY';  
  
DIMINFO(SDO_DIMNAME, SDO_LB, SDO_UB, SDO_TOLERANCE)  
-----  
SDO_DIM_ARRAY(SDO_DIM_ELEMENT('X', 0, 20, .005), SDO_DIM_ELEMENT('Y', 0, 20, .00  
5))
```

SDO_LRS.DEFINE_GEOM_SEGMENT

Format

```
SDO_LRS.DEFINE_GEOM_SEGMENT(  
    geom_segment IN OUT SDO_GEOMETRY  
    [, start_measure IN NUMBER,  
    end_measure IN NUMBER]);
```

or

```
SDO_LRS.DEFINE_GEOM_SEGMENT(  
    geom_segment IN OUT SDO_GEOMETRY,  
    dim_array IN SDO_DIM_ARRAY  
    [, start_measure IN NUMBER,  
    end_measure IN NUMBER]);
```

Description

Defines a geometric segment by assigning start and end measures to a geometric segment, and assigns values to any null measures.

Parameters

geom_segment

Cartographic representation of a linear feature.

dim_array

Dimensional information array corresponding to `geom_segment`, usually selected from one of the `xxx_SDO_GEOM_METADATA` views (described in [Section 2.8](#)).

start_measure

Distance measured from the start point of a geometric segment to the start point of the linear feature. The default is the existing value (if any) in the measure dimension; otherwise, the default is 0.

end_measure

Distance measured from the end point of a geometric segment to the start point of the linear feature. The default is the existing value (if any) in the measure dimension; otherwise, the default is the cartographic length of the segment.

Usage Notes

An exception is raised if `geom_segment` has an invalid geometry type or dimensionality, or if `start_measure` or `end_measure` is out of range.

All unassigned measures of the geometric segment will be populated automatically.

To store the resulting geometric segment (`geom_segment`) in the database, you must execute an UPDATE or INSERT statement, as appropriate.

The `_3D` format of this procedure (`SDO_LRS.DEFINE_GEOM_SEGMENT_3D`) is available. For information about `_3D` formats of LRS functions and procedures, see [Section 7.4](#).

For more information about defining a geometric segment, see [Section 7.5.1](#).

Examples

The following example defines the geometric segment, splits it into two segments, then concatenates those segments. (This example uses the definitions from the example in [Section 7.7](#). The definitions of `result_geom_1`, `result_geom_2`, and `result_geom_3` are displayed in [Example 7-3](#).)

```

DECLARE
geom_segment SDO_GEOMETRY;
line_string SDO_GEOMETRY;
dim_array SDO_DIM_ARRAY;
result_geom_1 SDO_GEOMETRY;
result_geom_2 SDO_GEOMETRY;
result_geom_3 SDO_GEOMETRY;

BEGIN

SELECT a.route_geometry into geom_segment FROM lrs_routes a
  WHERE a.route_name = 'Route1';
SELECT m.diminfo into dim_array from
  user_sdo_geom_metadata m
  WHERE m.table_name = 'LRS_ROUTES' AND m.column_name = 'ROUTE_GEOMETRY';

-- Define the LRS segment for Route1. This will populate any null measures.
SDO_LRS.DEFINE_GEOM_SEGMENT (geom_segment,
  dim_array,
  0,    -- Zero starting measure: LRS segment starts at start of route.
  27); -- End of LRS segment is at measure 27.

SELECT a.route_geometry INTO line_string FROM lrs_routes a
  WHERE a.route_name = 'Route1';

-- Split Route1 into two segments.
SDO_LRS.SPLIT_GEOM_SEGMENT(line_string,dim_array,5,result_geom_1,result_geom_2);

-- Concatenate the segments that were just split.
result_geom_3 := SDO_LRS.CONCATENATE_GEOM_SEGMENTS(result_geom_1, dim_array,
result_geom_2, dim_array);

-- Update and insert geometries into table, to display later.
UPDATE lrs_routes a SET a.route_geometry = geom_segment
  WHERE a.route_id = 1;

INSERT INTO lrs_routes VALUES(
  11,
  'result_geom_1',
  result_geom_1
);
INSERT INTO lrs_routes VALUES(
  12,
  'result_geom_2',
  result_geom_2
);
INSERT INTO lrs_routes VALUES(
  13,
  'result_geom_3',
  result_geom_3
);

```

```
END;  
/
```

SDO_LRS.DYNAMIC_SEGMENT

Format

```
SDO_LRS.DYNAMIC_SEGMENT(
    geom_segment IN SDO_GEOMETRY,
    start_measure IN NUMBER,
    end_measure   IN NUMBER,
    tolerance     IN NUMBER DEFAULT 1.0e-8
) RETURN SDO_GEOMETRY;
```

or

```
SDO_LRS.DYNAMIC_SEGMENT(
    geom_segment IN SDO_GEOMETRY,
    dim_array    IN SDO_DIM_ARRAY,
    start_measure IN NUMBER,
    end_measure   IN NUMBER
) RETURN SDO_GEOMETRY;
```

Description

Returns the geometry object resulting from a clip operation on a geometric segment.

Note: [SDO_LRS.CLIP_GEOM_SEGMENT](#) and [SDO_LRS.DYNAMIC_SEGMENT](#) are synonyms: both functions have the same parameters, behavior, and return value.

Parameters

geom_segment

Cartographic representation of a linear feature.

dim_array

Dimensional information array corresponding to `geom_segment`, usually selected from one of the `xxx_SDO_GEOM_METADATA` views (described in [Section 2.8](#)).

start_measure

Start measure of the geometric segment.

end_measure

End measure of the geometric segment.

tolerance

Tolerance value (see [Section 1.5.5](#) and [Section 7.6](#)). The default value is 0.00000001.

Usage Notes

An exception is raised if `geom_segment`, `start_measure`, or `end_measure` is invalid.

The direction and measures of the resulting geometric segment are preserved.

For more information about clipping a geometric segment, see [Section 7.5.3](#).

Examples

The following example clips the geometric segment representing Route 1, returning the segment from measures 5 through 10. This segment might represent a construction zone. (This example uses the definitions from the example in [Section 7.7](#).)

```
SELECT SDO_LRS.DYNAMIC_SEGMENT(route_geometry, 5, 10)
       FROM lrs_routes WHERE route_id = 1;
```

```
SDO_LRS.DYNAMIC_SEGMENT(ROUTE_GEOMETRY,5,10) (SDO_GTYPE, SDO_SRID, SDO_POINT(X, Y
-----
SDO_GEOMETRY(3302, NULL, NULL, SDO_ELEM_INFO_ARRAY(1, 2, 1), SDO_ORDINATE_ARRAY(
5, 4, 5, 8, 4, 8, 10, 4, 10))
```

SDO_LRS.FIND_LRS_DIM_POS

Format

```
SDO_LRS.FIND_LRS_DIM_POS(  
    table_name IN VARCHAR2,  
    column_name IN VARCHAR2  
) RETURN INTEGER;
```

Description

Returns the position of the measure dimension within the SDO_DIM_ARRAY structure for a specified SDO_GEOMETRY column.

Parameters

table_name

Table containing the column with the SDO_GEOMETRY objects.

column_name

Column in table_name containing the SDO_GEOMETRY objects.

Usage Notes

None.

Examples

The following example returns the position of the measure dimension within the SDO_DIM_ARRAY structure for geometries in the ROUTE_GEOMETRY column of the LRS_ROUTES table. (This example uses the definitions from the example in [Section 7.7](#).)

```
SELECT SDO_LRS.FIND_LRS_DIM_POS('LRS_ROUTES', 'ROUTE_GEOMETRY') FROM DUAL;
```

```
SDO_LRS.FIND_LRS_DIM_POS('LRS_ROUTES', 'ROUTE_GEOMETRY')
```

```
-----
```

3

SDO_LRS.FIND_MEASURE

Format

```
SDO_LRS.FIND_MEASURE(  
    geom_segment IN SDO_GEOMETRY,  
    point        IN SDO_GEOMETRY  
    ) RETURN NUMBER;
```

or

```
SDO_LRS.FIND_MEASURE(  
    geom_segment IN SDO_GEOMETRY,  
    dim_array    IN SDO_DIM_ARRAY,  
    point        IN SDO_GEOMETRY  
    ) RETURN NUMBER;
```

Description

Returns the measure of the closest point on a segment to a specified projection point.

Parameters

geom_segment

Cartographic representation of a linear feature. This function returns the measure of the point on this segment that is closest to the projection point.

dim_array

Dimensional information array corresponding to `geom_segment`, usually selected from one of the `xxx_SDO_GEOM_METADATA` views (described in [Section 2.8](#)).

point

Projection point. This function returns the measure of the point on `geom_segment` that is closest to the projection point.

Usage Notes

This function returns the measure of the point on `geom_segment` that is closest to the projection point. For example, if the projection point represents a shopping mall, the function could be used to find how far from the start of the highway is the point on the highway that is closest to the shopping mall.

An exception is raised if `geom_segment` has an invalid geometry type or dimensionality, or if `geom_segment` and `point` are based on different coordinate systems.

The `_3D` format of this function (`SDO_LRS.FIND_MEASURE_3D`) is available. For information about `_3D` formats of LRS functions, see [Section 7.4](#).

Examples

The following example finds the measure for the point on the geometric segment representing Route 1 that is closest to the point (10, 7). (This example uses the definitions from the example in [Section 7.7](#).)

```
-- Find measure for point on segment closest to 10,7.
-- Should return 15 (for point 12,7).
SELECT SDO_LRS.FIND_MEASURE(a.route_geometry, m.diminfo,
    SDO_GEOMETRY(3001, NULL, NULL,
        SDO_ELEM_INFO_ARRAY(1, 1, 1),
        SDO_ORDINATE_ARRAY(10, 7, NULL)) )
FROM lrs_routes a, user_sdo_geom_metadata m
WHERE m.table_name = 'LRS_ROUTES' AND m.column_name = 'ROUTE_GEOMETRY'
    AND a.route_id = 1;

SDO_LRS.FIND_MEASURE(A.ROUTE_GEOMETRY,M.DIMINFO,SDO_GEOMETRY(3001,NULL,NUL
```

15

SDO_LRS.FIND_OFFSET

Format

```
SDO_LRS.FIND_OFFSET(  
    geom_segment IN SDO_GEOMETRY,  
    point        IN SDO_GEOMETRY,  
    tolerance    IN NUMBER DEFAULT 1.0e-8  
    ) RETURN NUMBER;
```

or

```
SDO_LRS.FIND_OFFSET(  
    geom_segment IN SDO_GEOMETRY,  
    dim_array    IN SDO_DIM_ARRAY,  
    point        IN SDO_GEOMETRY  
    [, point_dim_array IN SDO_GEOMETRY]  
    ) RETURN NUMBER;
```

Description

Returns the signed offset (shortest distance) from a point to a geometric segment.

Parameters

geom_segment

Geometric segment to be checked for distance from `point`.

point

Point whose shortest distance from `geom_segment` is to be returned.

tolerance

Tolerance value (see [Section 1.5.5](#) and [Section 7.6](#)). The default value is 0.00000001.

dim_array

Dimensional information array corresponding to `geom_segment`, usually selected from one of the `xxx_SDO_GEOM_METADATA` views (described in [Section 2.8](#)).

point_dim_array

Dimensional information array corresponding to `point`, usually selected from one of the `xxx_SDO_GEOM_METADATA` views (described in [Section 2.8](#)).

Usage Notes

This function calls the [SDO_LRS.PROJECT_PT](#) function format that includes the `offset` output parameter: it passes in the geometric segment and point information, and it returns the [SDO_LRS.PROJECT_PT](#) `offset` parameter value. Thus, to find the offset of a point from a geometric segment, you can use either this function or the [SDO_LRS.PROJECT_PT](#) function with the `offset` parameter.

An exception is raised if `geom_segment` or `point` has an invalid geometry type or dimensionality, or if `geom_segment` and `point` are based on different coordinate systems.

For more information about offsets to a geometric segment, see [Section 7.1.5](#).

Examples

The following example returns the offset of point (9,3,NULL) from the geometric segment representing Route 1. (This example uses the definitions from the example in [Section 7.7](#).) As you can see from [Figure 7-20](#) in [Section 7.7](#), the point at (9,3,NULL) is on the right side along the segment, and therefore the offset has a negative value, as explained in [Section 7.1.5](#). The point at (9,3,NULL) is one distance unit away from the point at (9,4,NULL), which is on the segment.

```
-- Find the offset of point (9,3,NULL) from the road; should return -1.
SELECT  SDO_LRS.FIND_OFFSET(route_geometry,
        SDO_GEOMETRY(3301, NULL, NULL,
                    SDO_ELEM_INFO_ARRAY(1, 1, 1),
                    SDO_ORDINATE_ARRAY(9, 3, NULL)) )
FROM    lrs_routes WHERE route_id = 1;

SDO_LRS.FIND_OFFSET(ROUTE_GEOMETRY,SDO_GEOMETRY(3301,NULL,NULL,SDO_ELEM_INFO_ARR
-----
```

-1

SDO_LRS.GEOM_SEGMENT_END_MEASURE

Format

```
SDO_LRS.GEOM_SEGMENT_END_MEASURE(
  geom_segment IN SDO_GEOMETRY
  [, dim_array  IN SDO_DIM_ARRAY]
) RETURN NUMBER;
```

Description

Returns the end measure of a geometric segment.

Parameters

geom_segment

Geometric segment whose end measure is to be returned.

dim_array

Dimensional information array corresponding to `geom_segment`, usually selected from one of the `xxx_SDO_GEOM_METADATA` views (described in [Section 2.8](#)).

Usage Notes

This function returns the end measure of `geom_segment`.

An exception is raised if `geom_segment` has an invalid geometry type or dimensionality.

The *_3D* format of this function (`SDO_LRS.GEOM_SEGMENT_END_MEASURE_3D`) is available. For information about *_3D* formats of LRS functions, see [Section 7.4](#).

Examples

The following example returns the end measure of the geometric segment representing Route 1. (This example uses the definitions from the example in [Section 7.7](#).)

```
SELECT SDO_LRS.GEOM_SEGMENT_END_MEASURE(route_geometry)
       FROM lrs_routes WHERE route_id = 1;
```

```
SDO_LRS.GEOM_SEGMENT_END_MEASURE (ROUTE_GEOMETRY)
-----
```

27

SDO_LRS.GEOM_SEGMENT_END_PT

Format

```
SDO_LRS.GEOM_SEGMENT_END_PT(
    geom_segment IN SDO_GEOMETRY
    [, dim_array  IN SDO_DIM_ARRAY]
) RETURN SDO_GEOMETRY;
```

Description

Returns the end point of a geometric segment.

Parameters

geom_segment

Geometric segment whose end point is to be returned.

dim_array

Dimensional information array corresponding to `geom_segment`, usually selected from one of the `xxx_SDO_GEOM_METADATA` views (described in [Section 2.8](#)).

Usage Notes

This function returns the end point of `geom_segment`.

An exception is raised if `geom_segment` has an invalid geometry type or dimensionality.

The *_3D* format of this function (`SDO_LRS.GEOM_SEGMENT_END_PT_3D`) is available. For information about *_3D* formats of LRS functions, see [Section 7.4](#).

Examples

The following example returns the end point of the geometric segment representing Route 1. (This example uses the definitions from the example in [Section 7.7](#).)

```
SELECT SDO_LRS.GEOM_SEGMENT_END_PT(route_geometry)
FROM lrs_routes WHERE route_id = 1;
```

```
SDO_LRS.GEOM_SEGMENT_END_PT(ROUTE_GEOMETRY)(SDO_GTYPE, SDO_SRID, SDO_POINT(X, Y,
-----
SDO_GEOMETRY(3301, NULL, NULL, SDO_ELEM_INFO_ARRAY(1, 1, 1), SDO_ORDINATE_ARRAY(
5, 14, 27))
```

SDO_LRS.GEOM_SEGMENT_LENGTH

Format

```
SDO_LRS.GEOM_SEGMENT_LENGTH(  
    geom_segment IN SDO_GEOMETRY  
    [, dim_array  IN SDO_DIM_ARRAY]  
    ) RETURN NUMBER;
```

Description

Returns the length of a geometric segment.

Parameters

geom_segment

Geometric segment whose length is to be calculated.

dim_array

Dimensional information array corresponding to `geom_segment`, usually selected from one of the `xxx_SDO_GEOM_METADATA` views (described in [Section 2.8](#)).

Usage Notes

This function returns the length of `geom_segment`. The length is the geometric length, which is not the same as the total of the measure unit values. To determine how long a segment is in terms of measure units, subtract the result of an [SDO_LRS.GEOM_SEGMENT_START_MEASURE](#) operation from the result of an [SDO_LRS.GEOM_SEGMENT_END_MEASURE](#) operation.

An exception is raised if `geom_segment` has an invalid geometry type or dimensionality.

The `_3D` format of this function (`SDO_LRS.GEOM_SEGMENT_LENGTH_3D`) is available. For information about `_3D` formats of LRS functions, see [Section 7.4](#).

Examples

The following example returns the length of the geometric segment representing Route 1. (This example uses the definitions from the example in [Section 7.7](#).)

```
SELECT SDO_LRS.GEOM_SEGMENT_LENGTH(route_geometry)  
FROM lrs_routes WHERE route_id = 1;
```

```
SDO_LRS.GEOM_SEGMENT_LENGTH(ROUTE_GEOMETRY)  
-----
```

27

SDO_LRS.GEOM_SEGMENT_START_MEASURE

Format

```
SDO_LRS.GEOM_SEGMENT_START_MEASURE(
    geom_segment IN SDO_GEOMETRY
    [, dim_array  IN SDO_DIM_ARRAY]
) RETURN NUMBER;
```

Description

Returns the start measure of a geometric segment.

Parameters

geom_segment

Geometric segment whose start measure is to be returned.

dim_array

Dimensional information array corresponding to `geom_segment`, usually selected from one of the `xxx_SDO_GEOM_METADATA` views (described in [Section 2.8](#)).

Usage Notes

This function returns the start measure of `geom_segment`.

An exception is raised if `geom_segment` has an invalid geometry type or dimensionality.

The *_3D* format of this function (`SDO_LRS.GEOM_SEGMENT_START_MEASURE_3D`) is available. For information about *_3D* formats of LRS functions, see [Section 7.4](#).

Examples

The following example returns the start measure of the geometric segment representing Route 1. (This example uses the definitions from the example in [Section 7.7](#).)

```
SELECT  SDO_LRS.GEOM_SEGMENT_START_MEASURE(route_geometry)
        FROM lrs_routes WHERE route_id = 1;
```

```
SDO_LRS.GEOM_SEGMENT_START_MEASURE(ROUTE_GEOMETRY)
```

```
-----
0
```

SDO_LRS.GEOM_SEGMENT_START_PT

Format

```
SDO_LRS.GEOM_SEGMENT_START_PT(
    geom_segment IN SDO_GEOMETRY
    [, dim_array  IN SDO_DIM_ARRAY]
    ) RETURN SDO_GEOMETRY;
```

Description

Returns the start point of a geometric segment.

Parameters

geom_segment

Geometric segment whose start point is to be returned.

dim_array

Dimensional information array corresponding to `geom_segment`, usually selected from one of the `xxx_SDO_GEOM_METADATA` views (described in [Section 2.8](#)).

Usage Notes

This function returns the start point of `geom_segment`.

An exception is raised if `geom_segment` has an invalid geometry type or dimensionality.

The *_3D* format of this function (`SDO_LRS.GEOM_SEGMENT_START_PT_3D`) is available. For information about *_3D* formats of LRS functions, see [Section 7.4](#).

Examples

The following example returns the start point of the geometric segment representing Route 1. (This example uses the definitions from the example in [Section 7.7](#).)

```
SELECT  SDO_LRS.GEOM_SEGMENT_START_PT(route_geometry)
        FROM lrs_routes WHERE route_id = 1;

SDO_LRS.GEOM_SEGMENT_START_PT(ROUTE_GEOMETRY)(SDO_GTYPE, SDO_SRID, SDO_POINT(X,
-----
SDO_GEOMETRY(3301, NULL, NULL, SDO_ELEM_INFO_ARRAY(1, 1, 1), SDO_ORDINATE_ARRAY(
2, 2, 0))
```

SDO_LRS.GET_MEASURE

Format

```
SDO_LRS.GET_MEASURE(
    point      IN SDO_GEOMETRY
    [, dim_array IN SDO_DIM_ARRAY]
) RETURN NUMBER;
```

Description

Returns the measure of an LRS point.

Parameters

point

Point whose measure is to be returned.

dim_array

Dimensional information array corresponding to `point`, usually selected from one of the `xxx_SDO_GEOM_METADATA` views (described in [Section 2.8](#)).

Usage Notes

This function returns the measure of an LRS point.

If `point` is not valid, an "invalid LRS point" exception is raised.

Contrast this function with [SDO_LRS.PROJECT_PT](#), which accepts as input a point that is not necessarily on the geometric segment, but which returns a point that is on the geometric segment, as opposed to a measure value. As the following example shows, the `SDO_LRS.GET_MEASURE` function can be used to return the measure of the projected point returned by [SDO_LRS.PROJECT_PT](#).

The `_3D` format of this function (`SDO_LRS.GET_MEASURE_3D`) is available. For information about `_3D` formats of LRS functions, see [Section 7.4](#).

Examples

The following example returns the measure of a projected point. In this case, the point resulting from the projection is 9 units from the start of the segment.

```
SELECT SDO_LRS.GET_MEASURE(
    SDO_LRS.PROJECT_PT(a.route_geometry, m.diminfo,
        SDO_GEOMETRY(3001, NULL, NULL,
            SDO_ELEM_INFO_ARRAY(1, 1, 1),
            SDO_ORDINATE_ARRAY(9, 3, NULL)) ),
    m.diminfo )
FROM lrs_routes a, user_sdo_geom_metadata m
WHERE m.table_name = 'LRS_ROUTES' AND m.column_name = 'ROUTE_GEOMETRY'
AND a.route_id = 1;
```

```
SDO_LRS.GET_MEASURE(SDO_LRS.PROJECT_PT(A.ROUTE_GEOMETRY,M.DIMINFO,SDO_GEOM
```

SDO_LRS.GET_NEXT_SHAPE_PT

Format

```
SDO_LRS.GET_NEXT_SHAPE_PT(  
    geom_segment IN SDO_GEOMETRY,  
    measure      IN NUMBER  
    ) RETURN SDO_GEOMETRY;
```

or

```
SDO_LRS.GET_NEXT_SHAPE_PT(  
    geom_segment IN SDO_GEOMETRY,  
    dim_array    IN SDO_DIM_ARRAY,  
    measure      IN NUMBER  
    ) RETURN SDO_GEOMETRY;
```

or

```
SDO_LRS.GET_NEXT_SHAPE_PT(  
    geom_segment IN SDO_GEOMETRY,  
    point        IN SDO_GEOMETRY  
    ) RETURN SDO_GEOMETRY;
```

or

```
SDO_LRS.GET_NEXT_SHAPE_PT(  
    geom_segment IN SDO_GEOMETRY,  
    dim_array    IN SDO_DIM_ARRAY,  
    point        IN SDO_GEOMETRY  
    ) RETURN SDO_GEOMETRY;
```

Description

Returns the next shape point on a geometric segment after a specified measure value or LRS point.

Parameters

geom_segment

Geometric segment.

measure

Measure value on the geometric segment for which to return the next shape point.

point

Point for which to return the next shape point. If `point` is not on `geom_segment`, the point on the geometric segment closest to the specified point is computed, and the next shape point after that point is returned.

dim_array

Dimensional information array corresponding to `geom_segment`, usually selected from one of the `xxx_SDO_GEOM_METADATA` views (described in [Section 2.8](#)).

Usage Notes

If `measure` or `point` identifies the end point of the geometric segment, a null value is returned.

An exception is raised if `measure` is not a valid value for `geom_segment` or if `point` is not a valid LRS point.

Contrast this function with [SDO_LRS.GET_PREV_SHAPE_PT](#), which returns the previous shape point on a geometric segment before a specified measure value or LRS point.

The `_3D` format of this function ([SDO_LRS.GET_NEXT_SHAPE_PT_3D](#)) is available. For information about `_3D` formats of LRS functions, see [Section 7.4](#).

Examples

The following example returns the next shape point after measure 14 on the geometric segment representing Route 1. (This example uses the definitions from the example in [Section 7.7](#).)

```
SELECT SDO_LRS.GET_NEXT_SHAPE_PT(a.route_geometry, 14)
       FROM lrs_routes a WHERE a.route_id = 1;
```

```
SDO_LRS.GET_NEXT_SHAPE_PT(A.ROUTE_GEOMETRY,14) (SDO_GTYPE, SDO_SRID, SDO_POINT(X,
-----
SDO_GEOMETRY(3301, NULL, NULL, SDO_ELEM_INFO_ARRAY(1, 1, 1), SDO_ORDINATE_ARRAY(
12, 10, 18))
```

SDO_LRS.GET_NEXT_SHAPE_PT_MEASURE

Format

```
SDO_LRS.GET_NEXT_SHAPE_PT_MEASURE(  
    geom_segment IN SDO_GEOMETRY,  
    measure      IN NUMBER  
    ) RETURN NUMBER;
```

or

```
SDO_LRS.GET_NEXT_SHAPE_PT_MEASURE(  
    geom_segment IN SDO_GEOMETRY,  
    dim_array    IN SDO_DIM_ARRAY,  
    measure      IN NUMBER  
    ) RETURN NUMBER;
```

or

```
SDO_LRS.GET_NEXT_SHAPE_PT_MEASURE(  
    geom_segment IN SDO_GEOMETRY,  
    point        IN SDO_GEOMETRY  
    ) RETURN NUMBER;
```

or

```
SDO_LRS.GET_NEXT_SHAPE_PT_MEASURE(  
    geom_segment IN SDO_GEOMETRY,  
    dim_array    IN SDO_DIM_ARRAY,  
    point        IN SDO_GEOMETRY  
    ) RETURN NUMBER;
```

Description

Returns the measure value of the next shape point on a geometric segment after a specified measure value or LRS point.

Parameters

geom_segment

Geometric segment.

measure

Measure value on the geometric segment for which to return the measure value of the next shape point.

point

Point for which to return the measure value of the next shape point. If `point` is not on `geom_segment`, the point on the geometric segment closest to the specified point is computed, and the measure value of the next shape point after that point is returned.

dim_array

Dimensional information array corresponding to `geom_segment`, usually selected from one of the `xxx_SDO_GEOM_METADATA` views (described in [Section 2.8](#)).

Usage Notes

If `measure` or `point` identifies the end point of the geometric segment, a null value is returned.

An exception is raised if `measure` is not a valid value for `geom_segment` or if `point` is not a valid LRS point.

Contrast this function with [SDO_LRS.GET_PREV_SHAPE_PT_MEASURE](#), which returns the measure value of the previous shape point on a geometric segment before a specified measure value or LRS point.

The `_3D` format of this function (`SDO_LRS.GET_NEXT_SHAPE_PT_MEASURE_3D`) is available. For information about `_3D` formats of LRS functions, see [Section 7.4](#).

Examples

The following example returns the measure value of the next shape point after measure 14 on the geometric segment representing Route 1. (This example uses the definitions from the example in [Section 7.7](#).)

```
SELECT SDO_LRS.GET_NEXT_SHAPE_PT_MEASURE(a.route_geometry, 14)
       FROM lrs_routes a WHERE a.route_id = 1;
```

```
SDO_LRS.GET_NEXT_SHAPE_PT_MEASURE(A.ROUTE_GEOMETRY,14)
```

18

SDO_LRS.GET_PREV_SHAPE_PT

Format

```
SDO_LRS.GET_PREV_SHAPE_PT(  
    geom_segment IN SDO_GEOMETRY,  
    measure      IN NUMBER  
    ) RETURN SDO_GEOMETRY;
```

or

```
SDO_LRS.GET_PREV_SHAPE_PT(  
    geom_segment IN SDO_GEOMETRY,  
    dim_array    IN SDO_DIM_ARRAY,  
    measure      IN NUMBER  
    ) RETURN SDO_GEOMETRY;
```

or

```
SDO_LRS.GET_PREV_SHAPE_PT(  
    geom_segment IN SDO_GEOMETRY,  
    point        IN SDO_GEOMETRY  
    ) RETURN SDO_GEOMETRY;
```

or

```
SDO_LRS.GET_PREV_SHAPE_PT(  
    geom_segment IN SDO_GEOMETRY,  
    dim_array    IN SDO_DIM_ARRAY,  
    point        IN SDO_GEOMETRY  
    ) RETURN SDO_GEOMETRY;
```

Description

Returns the previous shape point on a geometric segment before a specified measure value or LRS point.

Parameters

geom_segment

Geometric segment.

measure

Measure value on the geometric segment for which to return the previous shape point.

point

Point for which to return the previous shape point. If `point` is not on `geom_segment`, the point on the geometric segment closest to the specified point is computed, and the closest shape point before that point is returned.

dim_array

Dimensional information array corresponding to `geom_segment`, usually selected from one of the `xxx_SDO_GEOM_METADATA` views (described in [Section 2.8](#)).

Usage Notes

If `measure` or `point` identifies the start point of the geometric segment, a null value is returned.

An exception is raised if `measure` is not a valid value for `geom_segment` or if `point` is not a valid LRS point.

Contrast this function with [SDO_LRS.GET_NEXT_SHAPE_PT](#), which returns the next shape point on a geometric segment after a specified measure value or LRS point.

The `_3D` format of this function (`SDO_LRS.GET_PREV_SHAPE_PT_3D`) is available. For information about `_3D` formats of LRS functions, see [Section 7.4](#).

Examples

The following example returns the closest shape point to measure 14 and before measure 14 on the geometric segment representing Route 1. (This example uses the definitions from the example in [Section 7.7](#).)

```
SELECT SDO_LRS.GET_PREV_SHAPE_PT(a.route_geometry, 14)
       FROM lrs_routes a WHERE a.route_id = 1;
```

```
SDO_LRS.GET_PREV_SHAPE_PT(A.ROUTE_GEOMETRY,14) (SDO_GTYPE, SDO_SRID, SDO_POINT(X,
-----
SDO_GEOMETRY(3301, NULL, NULL, SDO_ELEM_INFO_ARRAY(1, 1, 1), SDO_ORDINATE_ARRAY(
12, 4, 12))
```

SDO_LRS.GET_PREV_SHAPE_PT_MEASURE

Format

```
SDO_LRS.GET_PREV_SHAPE_PT_MEASURE(  
    geom_segment IN SDO_GEOMETRY,  
    measure      IN NUMBER  
    ) RETURN NUMBER;
```

or

```
SDO_LRS.GET_PREV_SHAPE_PT_MEASURE(  
    geom_segment IN SDO_GEOMETRY,  
    dim_array    IN SDO_DIM_ARRAY,  
    measure      IN NUMBER  
    ) RETURN NUMBER;
```

or

```
SDO_LRS.GET_PREV_SHAPE_PT_MEASURE(  
    geom_segment IN SDO_GEOMETRY,  
    point        IN SDO_GEOMETRY  
    ) RETURN NUMBER;
```

or

```
SDO_LRS.GET_PREV_SHAPE_PT_MEASURE(  
    geom_segment IN SDO_GEOMETRY,  
    dim_array    IN SDO_DIM_ARRAY,  
    point        IN SDO_GEOMETRY  
    ) RETURN NUMBER;
```

Description

Returns the measure value of the previous shape point on a geometric segment before a specified measure value or LRS point.

Parameters

geom_segment

Geometric segment.

measure

Measure value on the geometric segment for which to return the measure value of the previous shape point.

point

Point for which to return the measure value of the previous shape point. If `point` is not on `geom_segment`, the point on the geometric segment closest to the specified point is computed, and the measure value of the closest shape point before that point is returned.

dim_array

Dimensional information array corresponding to `geom_segment`, usually selected from one of the `xxx_SDO_GEOM_METADATA` views (described in [Section 2.8](#)).

Usage Notes

If `measure` or `point` identifies the start point of the geometric segment, a null value is returned.

An exception is raised if `measure` is not a valid value for `geom_segment` or if `point` is not a valid LRS point.

Contrast this function with [SDO_LRS.GET_NEXT_SHAPE_PT_MEASURE](#), which returns the measure value of the next shape point on a geometric segment after a specified measure value or LRS point.

The `_3D` format of this function ([SDO_LRS.GET_PREV_SHAPE_PT_MEASURE_3D](#)) is available. For information about `_3D` formats of LRS functions, see [Section 7.4](#).

Examples

The following example returns the measure value of the closest shape point to measure 14 and before measure 14 on the geometric segment representing Route 1. (This example uses the definitions from the example in [Section 7.7](#).)

```
SELECT SDO_LRS.GET_PREV_SHAPE_PT_MEASURE(a.route_geometry, 14)
       FROM lrs_routes a WHERE a.route_id = 1;
```

```
SDO_LRS.GET_PREV_SHAPE_PT_MEASURE(A.ROUTE_GEOMETRY,14)
```

```
-----
12
```

SDO_LRS.IS_GEOM_SEGMENT_DEFINED

Format

```
SDO_LRS.IS_GEOM_SEGMENT_DEFINED(  
    geom_segment IN SDO_GEOMETRY  
    [, dim_array  IN SDO_DIM_ARRAY]  
    ) RETURN VARCHAR2;
```

Description

Checks if an LRS segment is defined correctly.

Parameters

geom_segment

Geometric segment to be checked.

dim_array

Dimensional information array corresponding to `geom_segment`, usually selected from one of the `xxx_SDO_GEOM_METADATA` views (described in [Section 2.8](#)).

Usage Notes

This function returns TRUE if `geom_segment` is defined correctly and FALSE if `geom_segment` is not defined correctly.

The start and end measures of `geom_segment` must be defined (cannot be null), and any measures assigned must be in an ascending or descending order along the segment direction.

The `_3D` format of this function (`SDO_LRS.IS_GEOM_SEGMENT_DEFINED_3D`) is available. For information about `_3D` formats of LRS functions, see [Section 7.4](#).

See also the [SDO_LRS.VALID_GEOM_SEGMENT](#) function.

Examples

The following example checks if the geometric segment representing Route 1 is defined. (This example uses the definitions from the example in [Section 7.7](#).)

```
SELECT SDO_LRS.IS_GEOM_SEGMENT_DEFINED(route_geometry)  
       FROM lrs_routes WHERE route_id = 1;
```

```
SDO_LRS.IS_GEOM_SEGMENT_DEFINED(ROUTE_GEOMETRY)
```

```
-----  
TRUE
```

SDO_LRS.IS_MEASURE_DECREASING

Format

```
SDO_LRS.IS_MEASURE_DECREASING(
    geom_segment IN SDO_GEOMETRY
    [, dim_array  IN SDO_DIM_ARRAY]
) RETURN VARCHAR2;
```

Description

Checks if the measure values along an LRS segment are decreasing (that is, descending in numerical value).

Parameters

geom_segment

Geometric segment to be checked.

dim_array

Dimensional information array corresponding to `geom_segment`, usually selected from one of the `xxx_SDO_GEOM_METADATA` views (described in [Section 2.8](#)).

Usage Notes

This function returns TRUE if the measure values along an LRS segment are decreasing and FALSE if the measure values along an LRS segment are not decreasing.

The start and end measures of `geom_segment` must be defined (cannot be null).

The `_3D` format of this function (`SDO_LRS.IS_MEASURE_DECREASING_3D`) is available. For information about `_3D` formats of LRS functions, see [Section 7.4](#).

See also the [SDO_LRS.IS_MEASURE_INCREASING](#) function.

Examples

The following example checks if the measure values along the geometric segment representing Route 1 are decreasing. (This example uses the definitions from the example in [Section 7.7](#).)

```
SELECT SDO_LRS.IS_MEASURE_DECREASING(a.route_geometry, m.diminfo)
       FROM lrs_routes a, user_sdo_geom_metadata m
       WHERE m.table_name = 'LRS_ROUTES' AND m.column_name = 'ROUTE_GEOMETRY'
       AND a.route_id = 1;
```

```
SDO_LRS.IS_MEASURE_DECREASING(A.ROUTE_GEOMETRY,M.DIMINFO)
```

```
-----
FALSE
```

SDO_LRS.IS_MEASURE_INCREASING

Format

```
SDO_LRS.IS_MEASURE_INCREASING(  
    geom_segment IN SDO_GEOMETRY  
    [, dim_array  IN SDO_DIM_ARRAY]  
    ) RETURN VARCHAR2;
```

Description

Checks if the measure values along an LRS segment are increasing (that is, ascending in numerical value).

Parameters

geom_segment

Geometric segment to be checked.

dim_array

Dimensional information array corresponding to `geom_segment`, usually selected from one of the `xxx_SDO_GEOM_METADATA` views (described in [Section 2.8](#)).

Usage Notes

This function returns TRUE if the measure values along an LRS segment are increasing and FALSE if the measure values along an LRS segment are not increasing.

The start and end measures of `geom_segment` must be defined (cannot be null).

The `_3D` format of this function (`SDO_LRS.IS_MEASURE_INCREASING_3D`) is available. For information about `_3D` formats of LRS functions, see [Section 7.4](#).

See also the [SDO_LRS.IS_MEASURE_DECREASING](#) function.

Examples

The following example checks if the measure values along the geometric segment representing Route 1 are increasing. (This example uses the definitions from the example in [Section 7.7](#).)

```
SELECT SDO_LRS.IS_MEASURE_INCREASING(a.route_geometry, m.diminfo)  
    FROM lrs_routes a, user_sdo_geom_metadata m  
    WHERE m.table_name = 'LRS_ROUTES' AND m.column_name = 'ROUTE_GEOMETRY'  
    AND a.route_id = 1;
```

```
SDO_LRS.IS_MEASURE_INCREASING(A.ROUTE_GEOMETRY,M.DIMINFO)
```

```
-----  
TRUE
```

SDO_LRS.IS_SHAPE_PT_MEASURE

Format

```
SDO_LRS.IS_SHAPE_PT_MEASURE(
  geom_segment IN SDO_GEOMETRY,
  measure      IN NUMBER
) RETURN VARCHAR2;
```

or

```
SDO_LRS.IS_SHAPE_PT_MEASURE(
  geom_segment IN SDO_GEOMETRY,
  dim_array    IN SDO_DIM_ARRAY,
  measure      IN NUMBER
) RETURN VARCHAR2;
```

Description

Checks if a specified measure value is associated with a shape point on a geometric segment.

Parameters

geom_segment

Geometric segment to be checked.

measure

Measure value on the geometric segment to check if it is a shape point.

dim_array

Dimensional information array corresponding to `geom_segment`, usually selected from one of the `xxx_SDO_GEOM_METADATA` views (described in [Section 2.8](#)).

Usage Notes

This function returns TRUE if the specified measure value is associated with a shape point and FALSE if the measure value is not associated with a shape point.

An exception is raised if `measure` is not a valid value for `geom_segment`.

The `_3D` format of this function (`SDO_LRS.IS_SHAPE_PT_MEASURE_3D`) is available. For information about `_3D` formats of LRS functions, see [Section 7.4](#).

Examples

The following example checks if measure 14 on the geometric segment representing Route 1 is a shape point. (This example uses the definitions from the example in [Section 7.7](#).)

```
SELECT SDO_LRS.IS_SHAPE_PT_MEASURE(a.route_geometry, 14)
       FROM lrs_routes a WHERE a.route_id = 1;
```

```
SDO_LRS.IS_SHAPE_PT_MEASURE(A.ROUTE_GEOMETRY,14)
```

FALSE

SDO_LRS.LOCATE_PT

Format

```
SDO_LRS.LOCATE_PT(
    geom_segment IN SDO_GEOMETRY,
    measure      IN NUMBER
    [, offset    IN NUMBER
    ]
) RETURN SDO_GEOMETRY;
```

or

```
SDO_LRS.LOCATE_PT(
    geom_segment IN SDO_GEOMETRY,
    dim_array    IN SDO_DIM_ARRAY,
    measure      IN NUMBER
    [, offset    IN NUMBER]
) RETURN SDO_GEOMETRY;
```

Description

Returns the point located at a specified distance from the start of a geometric segment.

Parameters

geom_segment

Geometric segment to be checked to see if it falls within the measure range of `measure`.

dim_array

Dimensional information array corresponding to `geom_segment`, usually selected from one of the `xxx_SDO_GEOM_METADATA` views (described in [Section 2.8](#)).

measure

Distance to measure from the start point of `geom_segment`.

offset

Distance to measure perpendicularly from the point that is located at `measure` units from the start point of `geom_segment`. The default is 0 (that is, the point is on `geom_segment`).

Usage Notes

This function returns the referenced point. For example, on a highway, the point might represent the location of an accident.

The unit of measurement for `offset` is the same as for the coordinate system associated with `geom_segment`. For geodetic data, the default unit of measurement is meters.

With geodetic data using the WGS 84 coordinate system, this function can be used to return the longitude and latitude coordinates of any point on or offset from the segment.

An exception is raised if `geom_segment` has an invalid geometry type or dimensionality, or if the location is out of range.

The `_3D` format of this function (`SDO_LRS.LOCATE_PT_3D`) is available; however, the `offset` parameter is not available for `SDO_LRS.LOCATE_PT_3D`. For information about `_3D` formats of LRS functions, see [Section 7.4](#).

For more information about locating a point on a geometric segment, see [Section 7.5.8](#).

Examples

The following example creates a table for automobile accident data, inserts a record for an accident at the point at measure 9 and on (that is, offset 0) the geometric segment representing Route 1, and displays the data. (The accident table is deliberately oversimplified. This example also uses the route definition from the example in [Section 7.7](#).)

```
-- Create a table for accidents.
CREATE TABLE accidents (
  accident_id NUMBER PRIMARY KEY,
  route_id NUMBER,
  accident_geometry SDO_GEOMETRY);

-- Insert an accident record.
DECLARE
geom_segment SDO_GEOMETRY;

BEGIN

SELECT SDO_LRS.LOCATE_PT(a.route_geometry, 9, 0) into geom_segment
  FROM lrs_routes a WHERE a.route_name = 'Route1';

INSERT INTO accidents VALUES(1, 1, geom_segment);

END;
/

SELECT * from accidents;

ACCIDENT_ID    ROUTE_ID
-----
ACCIDENT_GEOMETRY(SDO_GTYPE, SDO_SRID, SDO_POINT(X, Y, Z), SDO_ELEM_INFO, SDO_OR
-----
                1          1
SDO_GEOMETRY(3301, NULL, NULL, SDO_ELEM_INFO_ARRAY(1, 1, 1), SDO_ORDINATE_ARRAY(
9, 4, 9))
```

SDO_LRS.LRS_INTERSECTION

Format

```
SDO_LRS.LRS_INTERSECTION(
    geom_1    IN SDO_GEOMETRY,
    dim_array_1 IN SDO_DIM_ARRAY,
    geom_2    IN SDO_GEOMETRY,
    dim_array_2 IN SDO_DIM_ARRAY
) RETURN SDO_GEOMETRY;
```

or

```
SDO_LRS.LRS_INTERSECTION(
    geom_1 IN SDO_GEOMETRY,
    geom_2 IN SDO_GEOMETRY,
    tolerance IN NUMBER
) RETURN SDO_GEOMETRY;
```

Description

Returns an LRS geometry object that is the topological intersection (AND operation) of two geometry objects where one or both are LRS geometries.

Parameters

geom_1

Geometry object.

dim_array_1

Dimensional information array corresponding to `geom_1`, usually selected from one of the `xxx_SDO_GEOM_METADATA` views (described in [Section 2.8](#)).

geom_2

Geometry object.

dim_array_2

Dimensional information array corresponding to `geom_2`, usually selected from one of the `xxx_SDO_GEOM_METADATA` views (described in [Section 2.8](#)).

tolerance

Tolerance value (see [Section 1.5.5](#)).

Usage Notes

This function performs essentially the same intersection operation as the [SDO_GEOM.SDO_INTERSECTION](#) function (described in [Chapter 24](#)), except that `SDO_LRS.LRS_INTERSECTION` is designed to return a valid LRS geometry (point, line string, or multiline string) where one or both of the geometry-related input parameters are LRS geometries. (If neither input geometry is an LRS geometry, this function operates the same as the [SDO_GEOM.SDO_INTERSECTION](#) function.)

The returned geometry is an LRS line string, multiline string, or point geometry that includes measure dimension information. The measure values reflect those in the first LRS geometry specified as an input parameter.

The first LRS geometry specified as an input parameter must not be a polygon; it must be a line string, multiline string, or point.

If an LRS line string (geometric segment) intersects a line string (LRS or standard), the result is an LRS point; if an LRS line string intersects a polygon, the result is an LRS line string.

An exception is raised if `geom_1` and `geom_2` are based on different coordinate systems.

Examples

The following example shows an LRS geometric segment (illustrated in [Figure 7–20](#) in [Section 7.7](#)) intersected by a vertical line from (8,2) to (8,6). The result is an LRS point geometry, in which the measure value (8) reflects the measure for that point (designated as Exit 3 in [Figure 7–20](#)) in the `geom_1` geometry. (This example uses the definitions from the example in [Section 7.7](#).)

```
-- Intersection of LRS segment and standard line segment
SELECT SDO_LRS.LRS_INTERSECTION(route_geometry,
    SDO_GEOMETRY(2002, NULL, NULL, SDO_ELEM_INFO_ARRAY(1,2,1),
        SDO_ORDINATE_ARRAY(8,2, 8,6)), 0.005)
FROM lrs_routes WHERE route_id = 1;

SDO_LRS.LRS_INTERSECTION(ROUTE_GEOMETRY,SDO_GEOMETRY(2002,NULL,NULL,SDO_ELEM_INF
-----
SDO_GEOMETRY(3301, NULL, NULL, SDO_ELEM_INFO_ARRAY(1, 1, 1), SDO_ORDINATE_ARRAY(
8, 4, 8))
```

The following example shows an LRS geometric segment (illustrated in [Figure 7–20](#) in [Section 7.7](#)) intersected by a vertical line from (12,2) to (12,6). The result is an LRS line string geometry, in which the measure values (12 and 14) reflect measures for points (the first of which is designated as Exit 4 in [Figure 7–20](#)) in the `geom_1` geometry. (This example uses the definitions from the example in [Section 7.7](#).)

```
SELECT SDO_LRS.LRS_INTERSECTION(route_geometry,
    SDO_GEOMETRY(2002, NULL, NULL, SDO_ELEM_INFO_ARRAY(1,2,1),
        SDO_ORDINATE_ARRAY(12,2, 12,6)), 0.005)
FROM lrs_routes WHERE route_id = 1;

SDO_LRS.LRS_INTERSECTION(ROUTE_GEOMETRY,SDO_GEOMETRY(2002,NULL,NULL,SDO_ELEM_INF
-----
SDO_GEOMETRY(3302, NULL, NULL, SDO_ELEM_INFO_ARRAY(1, 2, 1), SDO_ORDINATE_ARRAY(
12, 4, 12, 12, 6, 14))
```

SDO_LRS.MEASURE_RANGE

Format

```
SDO_LRS.MEASURE_RANGE(
    geom_segment IN SDO_GEOMETRY
    [, dim_array  IN SDO_DIM_ARRAY]
) RETURN NUMBER;
```

Description

Returns the measure range of a geometric segment, that is, the difference between the start measure and end measure.

Parameters

geom_segment

Cartographic representation of a linear feature.

dim_array

Dimensional information array corresponding to `geom_segment`, usually selected from one of the `xxx_SDO_GEOM_METADATA` views (described in [Section 2.8](#)).

Usage Notes

This function subtracts the start measure of `geom_segment` from the end measure of `geom_segment`.

The `_3D` format of this function (`SDO_LRS.MEASURE_RANGE_3D`) is available. For information about `_3D` formats of LRS functions, see [Section 7.4](#).

Examples

The following example returns the measure range of the geometric segment representing Route 1. (This example uses the definitions from the example in [Section 7.7](#).)

```
SELECT SDO_LRS.MEASURE_RANGE(route_geometry)
       FROM lrs_routes WHERE route_id = 1;
```

```
SDO_LRS.MEASURE_RANGE(ROUTE_GEOMETRY)
-----
```

27

SDO_LRS.MEASURE_TO_PERCENTAGE

Format

```
SDO_LRS.MEASURE_TO_PERCENTAGE(  
    geom_segment IN SDO_GEOMETRY,  
    measure      IN NUMBER  
    ) RETURN NUMBER;
```

or

```
SDO_LRS.MEASURE_TO_PERCENTAGE(  
    geom_segment IN SDO_GEOMETRY,  
    dim_array    IN SDO_DIM_ARRAY,  
    measure      IN NUMBER  
    ) RETURN NUMBER;
```

Description

Returns the percentage (0 to 100) that a specified measure is of the measure range of a geometric segment.

Parameters

geom_segment

Cartographic representation of a linear feature.

dim_array

Dimensional information array corresponding to `geom_segment`, usually selected from one of the `xxx_SDO_GEOM_METADATA` views (described in [Section 2.8](#)).

measure

Measure value. This function returns the percentage that this measure value is of the measure range.

Usage Notes

This function returns a number (0 to 100) that is the percentage of the measure range that the specified measure represents. (The measure range is the end measure minus the start measure.) For example, if the measure range of `geom_segment` is 50 and `measure` is 20, the function returns 40 (because $20/50 = 40\%$).

This function performs the reverse of the [SDO_LRS.PERCENTAGE_TO_MEASURE](#) function, which returns the measure that corresponds to a percentage value.

An exception is raised if `geom_segment` or `measure` is invalid.

Examples

The following example returns the percentage that 5 is of the measure range of the geometric segment representing Route 1. (This example uses the definitions from the example in [Section 7.7](#).) The measure range of this segment is 27, and 5 is approximately 18.5 percent of 27.

```
SELECT SDO_LRS.MEASURE_TO_PERCENTAGE(a.route_geometry, m.diminfo, 5)
FROM lrs_routes a, user_sdo_geom_metadata m
WHERE m.table_name = 'LRS_ROUTES' AND m.column_name = 'ROUTE_GEOMETRY'
AND a.route_id = 1;
```

```
SDO_LRS.MEASURE_TO_PERCENTAGE(A.ROUTE_GEOMETRY,M.DIMINFO,5)
-----
18.5185185
```

SDO_LRS.OFFSET_GEOM_SEGMENT

Format

```
SDO_LRS.OFFSET_GEOM_SEGMENT(  
    geom_segment IN SDO_GEOMETRY,  
    start_measure IN NUMBER,  
    end_measure  IN NUMBER,  
    offset       IN NUMBER,  
    tolerance    IN NUMBER DEFAULT 1.0e-8  
    [, unit      IN VARCHAR2]  
    ) RETURN SDO_GEOMETRY;
```

or

```
SDO_LRS.OFFSET_GEOM_SEGMENT(  
    geom_segment IN SDO_GEOMETRY,  
    dim_array    IN SDO_DIM_ARRAY,  
    start_measure IN NUMBER,  
    end_measure  IN NUMBER,  
    offset       IN NUMBER  
    [, unit      IN VARCHAR2]  
    ) RETURN SDO_GEOMETRY;
```

Description

Returns the geometric segment at a specified offset from a geometric segment.

Parameters

geom_segment

Cartographic representation of a linear feature.

dim_array

Dimensional information array corresponding to `geom_segment`, usually selected from one of the `xxx_SDO_GEOM_METADATA` views (described in [Section 2.8](#)).

start_measure

Start measure of `geom_segment` at which to start the offset operation.

end_measure

End measure of `geom_segment` at which to start the offset operation.

offset

Distance to measure perpendicularly from the points along `geom_segment`. Positive offset values are to the left of `geom_segment`; negative offset values are to the right of `geom_segment`.

tolerance

Tolerance value (see [Section 1.5.5](#) and [Section 7.6](#)). The default value is 0.00000001.

unit

Unit of measurement specification: a quoted string with one or both of the following keywords:

- `unit` and an `SDO_UNIT` value from the `MDSYS.SDO_DIST_UNITS` table. See [Section 2.10](#) for more information about unit of measurement specification.
- `arc_tolerance` and an arc tolerance value. See the Usage Notes for the [SDO_GEOM.SDO_ARC_DENSIFY](#) function in [Chapter 24](#) for more information about the `arc_tolerance` keyword.

For example: `'unit=km arc_tolerance=0.05'`

If the input geometry is geodetic data, this parameter is required, and `arc_tolerance` must be specified. If the input geometry is Cartesian or projected data, `arc_tolerance` has no effect and should not be specified.

If this parameter is not specified for a Cartesian or projected geometry, or if the `arc_tolerance` keyword is specified for a geodetic geometry but the `unit` keyword is not specified, the unit of measurement associated with the data is assumed.

Usage Notes

`start_measure` and `end_measure` can be any points on the geometric segment. They do not have to be in any specific order. For example, `start_measure` and `end_measure` can be 5 and 10, respectively, or 10 and 5, respectively.

The direction and measures of the resulting geometric segment are preserved (that is, they reflect the original segment).

The geometry type of `geom_segment` must be line or multiline. For example, it cannot be a polygon.

An exception is raised if `geom_segment`, `start_measure`, or `end_measure` is invalid.

Examples

The following example returns the geometric segment 2 distance units to the left (positive offset 2) of the segment from measures 5 through 10 of Route 1. Note in `SDO_ORDINATE_ARRAY` of the returned segment that the Y values (6) are 2 greater than the Y values (4) of the relevant part of the original segment. (This example uses the definitions from the example in [Section 7.7](#).)

```
-- Create a segment offset 2 to the left from measures 5 through 10.
-- First, display the original segment; then, offset.
SELECT a.route_geometry FROM lrs_routes a WHERE a.route_id = 1;

ROUTE_GEOMETRY(SDO_GTYPE, SDO_SRID, SDO_POINT(X, Y, Z), SDO_ELEM_INFO, SDO_ORDIN
-----
SDO_GEOMETRY(3302, NULL, NULL, SDO_ELEM_INFO_ARRAY(1, 2, 1), SDO_ORDINATE_ARRAY(
2, 2, 0, 2, 4, 2, 8, 4, 8, 12, 4, 12, 12, 10, 18, 8, 10, 22, 5, 14, 27))

SELECT SDO_LRS.OFFSET_GEOM_SEGMENT(a.route_geometry, m.diminfo, 5, 10, 2)
FROM lrs_routes a, user_sdo_geom_metadata m
WHERE m.table_name = 'LRS_ROUTES' AND m.column_name = 'ROUTE_GEOMETRY'
AND a.route_id = 1;

SDO_LRS.OFFSET_GEOM_SEGMENT(A.ROUTE_GEOMETRY,M.DIMINFO,5,10,2) (SDO_GTYPE, SDO_SR
```

```
-----  
SDO_GEOMETRY(3302, NULL, NULL, SDO_ELEM_INFO_ARRAY(1, 2, 1), SDO_ORDINATE_ARRAY(  
5, 6, 5, 10, 6, 10))
```

SDO_LRS.PERCENTAGE_TO_MEASURE

Format

```
SDO_LRS.PERCENTAGE_TO_MEASURE(  
    geom_segment IN SDO_GEOMETRY,  
    percentage    IN NUMBER  
) RETURN NUMBER;
```

or

```
SDO_LRS.PERCENTAGE_TO_MEASURE(  
    geom_segment IN SDO_GEOMETRY,  
    dim_array    IN SDO_DIM_ARRAY,  
    percentage    IN NUMBER  
) RETURN NUMBER;
```

Description

Returns the measure value of a specified percentage (0 to 100) of the measure range of a geometric segment.

Parameters

geom_segment

Cartographic representation of a linear feature.

dim_array

Dimensional information array corresponding to `geom_segment`, usually selected from one of the `xxx_SDO_GEOM_METADATA` views (described in [Section 2.8](#)).

percentage

Percentage value. Must be from 0 to 100. This function returns the measure value corresponding to this percentage of the measure range.

Usage Notes

This function returns the measure value corresponding to the specified percentage of the measure range. (The measure range is the end measure minus the start measure.) For example, if the measure range of `geom_segment` is 50 and `percentage` is 40, the function returns 20 (because 40% of 50 = 20).

This function performs the reverse of the [SDO_LRS.MEASURE_TO_PERCENTAGE](#) function, which returns the percentage value that corresponds to a measure.

An exception is raised if `geom_segment` has an invalid geometry type or dimensionality, or if `percentage` is less than 0 or greater than 100.

Examples

The following example returns the measure that is 50 percent of the measure range of the geometric segment representing Route 1. (This example uses the definitions from the example in [Section 7.7](#).) The measure range of this segment is 27, and 50 percent of 27 is 13.5.

```
SELECT SDO_LRS.PERCENTAGE_TO_MEASURE(a.route_geometry, m.diminfo, 50)
FROM lrs_routes a, user_sdo_geom_metadata m
WHERE m.table_name = 'LRS_ROUTES' AND m.column_name = 'ROUTE_GEOMETRY'
AND a.route_id = 1;
```

```
SDO_LRS.PERCENTAGE_TO_MEASURE(A.ROUTE_GEOMETRY,M.DIMINFO,50)
```

13.5

SDO_LRS.PROJECT_PT

Format

```
SDO_LRS.PROJECT_PT(
    geom_segment IN SDO_GEOMETRY,
    point        IN SDO_GEOMETRY,
    tolerance    IN NUMBER DEFAULT 1.0e-8
    [, offset    OUT NUMBER]
) RETURN SDO_GEOMETRY;
```

or

```
SDO_LRS.PROJECT_PT(
    geom_segment IN SDO_GEOMETRY,
    dim_array    IN SDO_DIM_ARRAY,
    point        IN SDO_GEOMETRY
    [, point_dim_array IN SDO_DIM_ARRAY]
) RETURN SDO_GEOMETRY;
```

or

```
SDO_LRS.PROJECT_PT(
    geom_segment IN SDO_GEOMETRY,
    dim_array    IN SDO_DIM_ARRAY,
    point        IN SDO_GEOMETRY,
    point_dim_array IN SDO_DIM_ARRAY
    [, offset    OUT NUMBER]
) RETURN SDO_GEOMETRY;
```

Description

Returns the projection point of a specified point. The projection point is on the geometric segment.

Parameters

geom_segment

Geometric segment to be checked.

dim_array

Dimensional information array corresponding to `geom_segment`, usually selected from one of the `xxx_SDO_GEOM_METADATA` views (described in [Section 2.8](#)).

point

Point to be projected.

tolerance

Tolerance value (see [Section 1.5.5](#) and [Section 7.6](#)). The default value is 0.00000001.

point_dim_array

Dimensional information array corresponding to `point`, usually selected from one of the `xxx_SDO_GEOM_METADATA` views (described in [Section 2.8](#)).

offset

Offset (shortest distance) from the point to the geometric segment.

Usage Notes

This function returns the projection point (including its measure) of a specified point (`point`). The projection point is on the geometric segment.

If multiple projection points exist, the first projection point encountered from the start point is returned.

If you specify the output parameter `offset`, the function stores the signed offset (shortest distance) from the point to the geometric segment. For more information about the offset to a geometric segment, see [Section 7.1.5](#).

An exception is raised if `geom_segment` or `point` has an invalid geometry type or dimensionality, or if `geom_segment` and `point` are based on different coordinate systems.

The `_3D` format of this function (`SDO_LRS.PROJECT_PT_3D`) is available. For information about `_3D` formats of LRS functions, see [Section 7.4](#).

For more information about projecting a point onto a geometric segment, see [Section 7.5.9](#).

Examples

The following example returns the point (9,4,9) on the geometric segment representing Route 1 that is closest to the specified point (9,3,NULL). (This example uses the definitions from the example in [Section 7.7](#).)

```
-- Point 9,3,NULL is off the road; should return 9,4,9.
SELECT  SDO_LRS.PROJECT_PT(route_geometry,
      SDO_GEOOMETRY(3301, NULL, NULL,
        SDO_ELEM_INFO_ARRAY(1, 1, 1),
        SDO_ORDINATE_ARRAY(9, 3, NULL)) )
FROM    lrs_routes WHERE route_id = 1;

SDO_LRS.PROJECT_PT(ROUTE_GEOOMETRY, SDO_GEOOMETRY(3301, NULL, NULL, SDO_EL
-----
SDO_GEOOMETRY(3301, NULL, NULL, SDO_ELEM_INFO_ARRAY(1, 1, 1), SDO_ORDINATE_ARRAY(
9, 4, 9))
```

SDO_LRS.REDEFINE_GEOM_SEGMENT

Format

```
SDO_LRS.REDEFINE_GEOM_SEGMENT(
    geom_segment IN OUT SDO_GEOMETRY
    [, start_measure IN NUMBER,
    end_measure IN NUMBER]);
```

or

```
SDO_LRS.REDEFINE_GEOM_SEGMENT(
    geom_segment IN OUT SDO_GEOMETRY,
    dim_array IN SDO_DIM_ARRAY
    [, start_measure IN NUMBER,
    end_measure IN NUMBER]);
```

Description

Populates the measures of all shape points based on the start and end measures of a geometric segment, overriding any previously assigned measures between the start point and end point.

Parameters

geom_segment

Cartographic representation of a linear feature.

dim_array

Dimensional information array corresponding to `geom_segment`, usually selected from one of the `xxx_SDO_GEOM_METADATA` views (described in [Section 2.8](#)).

start_measure

Distance measured from the start point of a geometric segment to the start point of the linear feature. The default is the existing value (if any) in the measure dimension; otherwise, the default is 0.

end_measure

Distance measured from the end point of a geometric segment to the start point of the linear feature. The default is the existing value (if any) in the measure dimension; otherwise, the default is the cartographic length of the segment.

Usage Notes

An exception is raised if `geom_segment` has an invalid geometry type or dimensionality, or if `start_measure` or `end_measure` is out of range.

The `_3D` format of this procedure (`SDO_LRS.REDEFINE_GEOM_SEGMENT_3D`) is available. For information about `_3D` formats of LRS functions and procedures, see [Section 7.4](#).

For more information about redefining a geometric segment, see [Section 7.5.2](#).

Examples

The following example redefines a geometric segment, effectively converting miles to kilometers in the measure values. (This example uses the definitions from the example in [Section 7.7](#).)

```
-- First, display the original segment; then, redefine.
SELECT a.route_geometry FROM lrs_routes a WHERE a.route_id = 1;

ROUTE_GEOMETRY(SDO_GTYPE, SDO_SRID, SDO_POINT(X, Y, Z), SDO_ELEM_INFO, SDO_ORDIN
-----
SDO_GEOMETRY(3302, NULL, NULL, SDO_ELEM_INFO_ARRAY(1, 2, 1), SDO_ORDINATE_ARRAY(
2, 2, 0, 2, 4, 2, 8, 4, 8, 12, 4, 12, 12, 10, 18, 8, 10, 22, 5, 14, 27))

-- Redefine geometric segment to "convert" miles to kilometers.
DECLARE
geom_segment SDO_GEOMETRY;
dim_array SDO_DIM_ARRAY;

BEGIN

SELECT a.route_geometry into geom_segment FROM lrs_routes a
  WHERE a.route_name = 'Route1';
SELECT m.diminfo into dim_array from
  user_sdo_geom_metadata m
  WHERE m.table_name = 'LRS_ROUTES' AND m.column_name = 'ROUTE_GEOMETRY';

-- "Convert" mile measures to kilometers (27 * 1.609 = 43.443).
SDO_LRS.REDEFINE_GEOM_SEGMENT (geom_segment,
  dim_array,
  0,    -- Zero starting measure: LRS segment starts at start of route.
  43.443); -- End of LRS segment. 27 miles = 43.443 kilometers.

-- Update and insert geometries into table, to display later.
UPDATE lrs_routes a SET a.route_geometry = geom_segment
  WHERE a.route_id = 1;

END;
/

PL/SQL procedure successfully completed.

-- Display the redefined segment, with all measures "converted."
SELECT a.route_geometry FROM lrs_routes a WHERE a.route_id = 1;

ROUTE_GEOMETRY(SDO_GTYPE, SDO_SRID, SDO_POINT(X, Y, Z), SDO_ELEM_INFO, SDO_ORDIN
-----
SDO_GEOMETRY(3302, NULL, NULL, SDO_ELEM_INFO_ARRAY(1, 2, 1), SDO_ORDINATE_ARRAY(
2, 2, 0, 2, 4, 3.218, 8, 4, 12.872, 12, 4, 19.308, 12, 10, 28.962, 8, 10, 35.398
, 5, 14, 43.443))
```

SDO_LRS.RESET_MEASURE

Format

```
SDO_LRS.RESET_MEASURE(
    geom_segment IN OUT SDO_GEOMETRY
    [, dim_array IN SDO_DIM_ARRAY]);
```

Description

Sets all measures of a geometric segment, including the start and end measures, to null values, overriding any previously assigned measures.

Parameters

geom_segment

Cartographic representation of a linear feature.

dim_array

Dimensional information array corresponding to `geom_segment`, usually selected from one of the `xxx_SDO_GEOM_METADATA` views (described in [Section 2.8](#)).

Usage Notes

An exception is raised if `geom_segment` has an invalid geometry type or dimensionality.

Examples

The following example sets all measures of a geometric segment to null values. (This example uses the definitions from the example in [Section 7.7](#).)

```
-- First, display the original segment; then, redefine.
SELECT a.route_geometry FROM lrs_routes a WHERE a.route_id = 1;

ROUTE_GEOMETRY(SDO_GTYPE, SDO_SRID, SDO_POINT(X, Y, Z), SDO_ELEM_INFO, SDO_ORDIN
-----
SDO_GEOMETRY(3302, NULL, NULL, SDO_ELEM_INFO_ARRAY(1, 2, 1), SDO_ORDINATE_ARRAY(
2, 2, 0, 2, 4, 2, 8, 4, 8, 12, 4, 12, 12, 10, 18, 8, 10, 22, 5, 14, 27))

-- Reset geometric segment measures.
DECLARE
geom_segment SDO_GEOMETRY;

BEGIN

SELECT a.route_geometry into geom_segment FROM lrs_routes a
    WHERE a.route_name = 'Route1';

SDO_LRS.RESET_MEASURE (geom_segment);

-- Update and insert geometries into table, to display later.
UPDATE lrs_routes a SET a.route_geometry = geom_segment
    WHERE a.route_id = 1;

END;
/
```

PL/SQL procedure successfully completed.

-- Display the segment, with all measures set to null.

```
SELECT a.route_geometry FROM lrs_routes a WHERE a.route_id = 1;
```

```
ROUTE_GEOMETRY(SDO_GTYPE, SDO_SRID, SDO_POINT(X, Y, Z), SDO_ELEM_INFO, SDO_ORDIN
```

```
-----  
SDO_GEOMETRY(3302, NULL, NULL, SDO_ELEM_INFO_ARRAY(1, 2, 1), SDO_ORDINATE_ARRAY(  
2, 2, NULL, 2, 4, NULL, 8, 4, NULL, 12, 4, NULL, 12, 10, NULL, 8, 10, NULL, 5, 1  
4, NULL))
```

SDO_LRS.REVERSE_GEOMETRY

Format

```
SDO_LRS.REVERSE_GEOMETRY(
    geom          IN SDO_GEOMETRY
    [, dim_array  IN SDO_DIM_ARRAY]
) RETURN SDO_GEOMETRY;
```

Description

Returns a new geometric segment by reversing the measure values and the direction of the original geometric segment.

Parameters

geom

Cartographic representation of a linear feature.

dim_array

Dimensional information array corresponding to `geom`, usually selected from one of the `xxx_SDO_GEOM_METADATA` views (described in [Section 2.8](#)).

Usage Notes

This function:

- Reverses the measure values of `geom`

That is, the start measure of `geom` is the end measure of the returned geometric segment, the end measure of `geom` is the start measure of the returned geometric segment, and all other measures are adjusted accordingly.
- Reverses the direction of `geom`

Compare this function with [SDO_LRS.REVERSE_MEASURE](#), which reverses only the measure values (not the direction) of a geometric segment.

To reverse the vertices of a non-LRS line string geometry, use the [SDO_UTIL.REVERSE_LINestring](#) function, which is described in [Chapter 32](#).

An exception is raised if `geom` has an invalid geometry type or dimensionality. The geometry type must be a line or multiline, and the dimensionality must be 3 (two dimensions plus the measure dimension).

The `_3D` format of this function (`SDO_LRS.REVERSE_GEOMETRY_3D`) is available. For information about `_3D` formats of LRS functions, see [Section 7.4](#).

Examples

The following example reverses the measure values and the direction of the geometric segment representing Route 1. (This example uses the definitions from the example in [Section 7.7](#).)

```
-- Reverse direction and measures (for example, to prepare for
-- concatenating with another road).
-- First, display the original segment; then, reverse.
SELECT a.route_geometry FROM lrs_routes a WHERE a.route_id = 1;
```

```
ROUTE_GEOMETRY(SDO_GTYPE, SDO_SRID, SDO_POINT(X, Y, Z), SDO_ELEM_INFO, SDO_ORDINATE_ARRAY(
-----
SDO_GEOMETRY(3302, NULL, NULL, SDO_ELEM_INFO_ARRAY(1, 2, 1), SDO_ORDINATE_ARRAY(
2, 2, 0, 2, 4, 2, 8, 4, 8, 12, 4, 12, 12, 10, 18, 8, 10, 22, 5, 14, 27))
```

```
SELECT SDO_LRS.REVERSE_GEOMETRY(a.route_geometry, m.diminfo)
FROM lrs_routes a, user_sdo_geom_metadata m
WHERE m.table_name = 'LRS_ROUTES' AND m.column_name = 'ROUTE_GEOMETRY'
AND a.route_id = 1;
```

```
SDO_LRS.REVERSE_GEOMETRY(A.ROUTE_GEOMETRY,M.DIMINFO) (SDO_GTYPE, SDO_SRID, SDO_PO
-----
SDO_GEOMETRY(3302, NULL, NULL, SDO_ELEM_INFO_ARRAY(1, 2, 1), SDO_ORDINATE_ARRAY(
5, 14, 27, 8, 10, 22, 12, 10, 18, 12, 4, 12, 8, 4, 8, 2, 4, 2, 2, 2, 0))
```

Note in the returned segment that the M values (measures) now go in descending order from 27 to 0, and the segment start and end points have the opposite X and Y values as in the original segment (5,14 and 2,2 here, as opposed to 2,2 and 5,14 in the original).

SDO_LRS.REVERSE_MEASURE

Format

```
SDO_LRS.REVERSE_MEASURE(
    geom_segment IN SDO_GEOMETRY
    [, dim_array  IN SDO_DIM_ARRAY]
) RETURN SDO_GEOMETRY;
```

Description

Returns a new geometric segment by reversing the measure values, but not the direction, of the original geometric segment.

Parameters

geom_segment

Cartographic representation of a linear feature.

dim_array

Dimensional information array corresponding to `geom_segment`, usually selected from one of the `xxx_SDO_GEOM_METADATA` views (described in [Section 2.8](#)).

Usage Notes

This function:

- Reverses the measure values of `geom_segment`

That is, the start measure of `geom_segment` is the end measure of the returned geometric segment, the end measure of `geom_segment` is the start measure of the returned geometric segment, and all other measures are adjusted accordingly.
- Does not affect the direction of `geom_segment`

Compare this function with [SDO_LRS.REVERSE_GEOMETRY](#), which reverses both the direction and the measure values of a geometric segment.

An exception is raised if `geom_segment` has an invalid geometry type or dimensionality.

The `_3D` format of this function (`SDO_LRS.REVERSE_MEASURE_3D`) is available. For information about `_3D` formats of LRS functions, see [Section 7.4](#).

Note: The behavior of the `SDO_LRS.REVERSE_MEASURE` function changed after release 8.1.7. In release 8.1.7, `REVERSE_MEASURE` reversed both the measures and the segment direction. However, if you want to have this same behavior with subsequent releases, you must use the [SDO_LRS.REVERSE_GEOMETRY](#) function.

Examples

The following example reverses the measure values of the geometric segment representing Route 1, but does not affect the direction. (This example uses the definitions from the example in [Section 7.7](#).)

```
-- First, display the original segment; then, reverse.
SELECT a.route_geometry FROM lrs_routes a WHERE a.route_id = 1;

ROUTE_GEOMETRY(SDO_GTYPE, SDO_SRID, SDO_POINT(X, Y, Z), SDO_ELEM_INFO, SDO_ORDIN
-----
SDO_GEOMETRY(3302, NULL, NULL, SDO_ELEM_INFO_ARRAY(1, 2, 1), SDO_ORDINATE_ARRAY(
2, 2, 0, 2, 4, 2, 8, 4, 8, 12, 4, 12, 12, 10, 18, 8, 10, 22, 5, 14, 27))
```

```
SELECT SDO_LRS.REVERSE_MEASURE(a.route_geometry, m.diminfo)
FROM lrs_routes a, user_sdo_geom_metadata m
WHERE m.table_name = 'LRS_ROUTES' AND m.column_name = 'ROUTE_GEOMETRY'
AND a.route_id = 1;
```

```
SDO_LRS.REVERSE_MEASURE(A.ROUTE_GEOMETRY,M.DIMINFO) (SDO_GTYPE, SDO_SRID, SDO_POI
-----
SDO_GEOMETRY(3302, NULL, NULL, SDO_ELEM_INFO_ARRAY(1, 2, 1), SDO_ORDINATE_ARRAY(
2, 2, 27, 2, 4, 25, 8, 4, 19, 12, 4, 15, 12, 10, 9, 8, 10, 5, 5, 14, 0))
```

Note in the returned segment that the M values (measures) now go in descending order from 27 to 0, but the segment start and end points have the same X and Y values as in the original segment (2,2 and 5,14).

SDO_LRS.SCALE_GEOM_SEGMENT

Format

```
SDO_LRS.SCALE_GEOM_SEGMENT(  
    geom_segment IN SDO_GEOMETRY,  
    start_measure IN NUMBER,  
    end_measure  IN NUMBER,  
    shift_measure IN NUMBER,  
    tolerance    IN NUMBER DEFAULT 1.0e-8  
) RETURN SDO_GEOMETRY;
```

or

```
SDO_LRS.SCALE_GEOM_SEGMENT(  
    geom_segment IN SDO_GEOMETRY,  
    dim_array    IN SDO_DIM_ARRAY,  
    start_measure IN NUMBER,  
    end_measure  IN NUMBER,  
    shift_measure IN NUMBER,  
) RETURN SDO_GEOMETRY;
```

Description

Returns the geometry object resulting from a measure scaling operation on a geometric segment.

Parameters

geom_segment

Cartographic representation of a linear feature.

dim_array

Dimensional information array corresponding to `geom_segment`, usually selected from one of the `xxx_SDO_GEOM_METADATA` views (described in [Section 2.8](#)).

start_measure

Start measure of the geometric segment.

end_measure

End measure of the geometric segment.

shift_measure

Amount to be added to each measure value after the initial scaling. A value of 0 (zero) means that nothing is added (no shifting of measure values).

tolerance

Tolerance value (see [Section 1.5.5](#) and [Section 7.6](#)). The default value is 0.00000001.

Usage Notes

This function performs the following actions:

1. It redistributes the measure values of the LRS geometric segment, using between `start_measure` for the start point and `end_measure` for the end point, and adjusting (scaling) the measure values in between accordingly.
2. If `shift_measure` is not 0 (zero), it translates (shifts) each measure value computed in step 1 by adding the `shift_measure` value.

The action of this function is sometimes referred to as "stretching" the measure values. The function affects only the measure values; the other coordinates of the geometry are not changed.

An exception is raised if `geom_segment`, `start_measure`, or `end_measure` is invalid.

The direction of the resulting geometric segment is preserved (that is, it reflects the original segment).

For more information about scaling geometric segments, see [Section 7.5.6](#).

Examples

The following example scales the geometric segment representing Route 1, returning a segment in which the start measure is specified as 100, the end measure is specified 200, with a shift measure value of 10. Consequently, after all measure values are scaled according to the start and end measure values, 10 is added to all measure values. Thus, for example, the start point measure is 110 and the end point measure is 210 in the returned geometry. (This example uses the definitions from the example in [Section 7.7](#).)

```
SQL> SELECT SDO_LRS.SCALE_GEOM_SEGMENT(route_geometry, 100, 200, 10)
        FROM lrs_routes WHERE route_id = 1;
```

```
SDO_LRS.SCALE_GEOM_SEGMENT(ROUTE_GEOMETRY,100,200,10) (SDO_GTYPE, SDO_SRID, SDO_P
-----
SDO_GEOMETRY(3302, NULL, NULL, SDO_ELEM_INFO_ARRAY(1, 2, 1), SDO_ORDINATE_ARRAY(
2, 2, 110, 2, 4, 117.407407, 8, 4, 139.62963, 12, 4, 154.444444, 12, 10, 176.666
667, 8, 10, 191.481481, 5, 14, 210))
```

SDO_LRS.SET_PT_MEASURE

Format

```
SDO_LRS.SET_PT_MEASURE(
    geom_segment IN OUT SDO_GEOMETRY,
    point        IN SDO_GEOMETRY,
    measure      IN NUMBER) RETURN VARCHAR2;
```

or

```
SDO_LRS.SET_PT_MEASURE(
    geom_segment IN OUT SDO_GEOMETRY,
    dim_array    IN SDO_DIM_ARRAY,
    point        IN SDO_GEOMETRY,
    pt_dim_array IN SDO_DIM_ARRAY,
    measure      IN NUMBER) RETURN VARCHAR2;
```

or

```
SDO_LRS.SET_PT_MEASURE(
    point IN OUT SDO_GEOMETRY,
    measure IN NUMBER) RETURN VARCHAR2;
```

or

```
SDO_LRS.SET_PT_MEASURE(
    point IN OUT SDO_GEOMETRY,
    dim_array IN SDO_DIM_ARRAY,
    measure IN NUMBER) RETURN VARCHAR2;
```

Description

Sets the measure value of a specified point.

Parameters

geom_segment

Geometric segment containing the point.

dim_array

Dimensional information array corresponding to `geom_segment` (in the second format) or `point` (in the fourth format), usually selected from one of the xxx_SDO_GEOG_METADATA views (described in [Section 2.8](#)).

point

Point for which the measure value is to be set.

pt_dim_array

Dimensional information array corresponding to `point` (in the second format), usually selected from one of the `xxx_SDO_GEOM_METADATA` views (described in [Section 2.8](#)).

measure

Measure value to be assigned to the specified point.

Usage Notes

The function returns `TRUE` if the measure value was successfully set, and `FALSE` if the measure value was not set.

If both `geom_segment` and `point` are specified, the behavior of the procedure depends on whether or not `point` is a shape point on `geom_segment`:

- If `point` is a shape point on `geom_segment`, the measure value of `point` is set.
- If `point` is not a shape point on `geom_segment`, the shape point on `geom_segment` that is nearest to `point` is found, and the measure value of that shape point is set.

The `_3D` format of this function (`SDO_LRS.SET_PT_MEASURE_3D`) is available; however, only the formats that include the `geom_segment` parameter are available for `SDO_LRS.SET_PT_MEASURE_3D`. For information about `_3D` formats of LRS functions, see [Section 7.4](#).

An exception is raised if `geom_segment` or `point` is invalid.

Examples

The following example sets the measure value of point (8,10) to 20. (This example uses the definitions from the example in [Section 7.7](#).)

```
-- Set the measure value of point 8,10 to 20 (originally 22).
DECLARE
geom_segment SDO_GEOMETRY;
dim_array SDO_DIM_ARRAY;
result VARCHAR2(32);

BEGIN

SELECT a.route_geometry into geom_segment FROM lrs_routes a
WHERE a.route_name = 'Route1';
SELECT m.diminfo into dim_array from
user_sdo_geom_metadata m
WHERE m.table_name = 'LRS_ROUTES' AND m.column_name = 'ROUTE_GEOMETRY';

-- Set the measure value of point 8,10 to 20 (originally 22).
result := SDO_LRS.SET_PT_MEASURE (geom_segment,
SDO_GEOMETRY(3301, NULL, NULL,
SDO_ELEM_INFO_ARRAY(1, 1, 1),
SDO_ORDINATE_ARRAY(8, 10, 22)),
20);

-- Display the result.
DBMS_OUTPUT.PUT_LINE('Returned value = ' || result);

END;
/
Returned value = TRUE
```

PL/SQL procedure successfully completed.

SDO_LRS.SPLIT_GEOM_SEGMENT

Format

```
SDO_LRS.SPLIT_GEOM_SEGMENT(  
    geom_segment IN SDO_GEOMETRY,  
    split_measure IN NUMBER,  
    segment_1    OUT SDO_GEOMETRY,  
    segment_2    OUT SDO_GEOMETRY);
```

or

```
SDO_LRS.SPLIT_GEOM_SEGMENT(  
    geom_segment IN SDO_GEOMETRY,  
    dim_array    IN SDO_DIM_ARRAY,  
    split_measure IN NUMBER,  
    segment_1    OUT SDO_GEOMETRY,  
    segment_2    OUT SDO_GEOMETRY);
```

Description

Splits a geometric segment into two geometric segments.

Parameters

geom_segment

Geometric segment to be split.

dim_array

Dimensional information array corresponding to `geom_segment`, usually selected from one of the `xxx_SDO_GEOM_METADATA` views (described in [Section 2.8](#)).

split_measure

Distance measured from the start point of a geometric segment to the split point.

segment_1

First geometric segment: from the start point of `geom_segment` to the split point.

segment_2

Second geometric segment: from the split point to the end point of `geom_segment`.

Usage Notes

An exception is raised if `geom_segment` or `split_measure` is invalid.

The directions and measures of the resulting geometric segments are preserved.

The `_3D` format of this procedure (`SDO_LRS.SPLIT_GEOM_SEGMENT_3D`) is available. For information about `_3D` formats of LRS functions and procedures, see [Section 7.4](#).

For more information about splitting a geometric segment, see [Section 7.5.4](#).

Examples

The following example defines the geometric segment, splits it into two segments, then concatenates those segments. (This example uses the definitions from the example in [Section 7.7](#). The definitions of `result_geom_1`, `result_geom_2`, and `result_geom_3` are displayed in [Example 7-3](#).)

```

DECLARE
geom_segment SDO_GEOMETRY;
line_string SDO_GEOMETRY;
dim_array SDO_DIM_ARRAY;
result_geom_1 SDO_GEOMETRY;
result_geom_2 SDO_GEOMETRY;
result_geom_3 SDO_GEOMETRY;

BEGIN

SELECT a.route_geometry into geom_segment FROM lrs_routes a
  WHERE a.route_name = 'Route1';
SELECT m.diminfo into dim_array from
  user_sdo_geom_metadata m
  WHERE m.table_name = 'LRS_ROUTES' AND m.column_name = 'ROUTE_GEOMETRY';

-- Define the LRS segment for Route1.
SDO_LRS.DEFINE_GEOM_SEGMENT (geom_segment,
  dim_array,
  0,    -- Zero starting measure: LRS segment starts at start of route.
  27); -- End of LRS segment is at measure 27.

SELECT a.route_geometry INTO line_string FROM lrs_routes a
  WHERE a.route_name = 'Route1';

-- Split Route1 into two segments.
SDO_LRS.SPLIT_GEOM_SEGMENT(line_string,dim_array,5,result_geom_1,result_geom_2);

-- Concatenate the segments that were just split.
result_geom_3 := SDO_LRS.CONCATENATE_GEOM_SEGMENTS(result_geom_1, dim_array,
result_geom_2, dim_array);

-- Insert geometries into table, to display later.
INSERT INTO lrs_routes VALUES(
  11,
  'result_geom_1',
  result_geom_1
);
INSERT INTO lrs_routes VALUES(
  12,
  'result_geom_2',
  result_geom_2
);
INSERT INTO lrs_routes VALUES(
  13,
  'result_geom_3',
  result_geom_3
);

END;
/

```

SDO_LRS.TRANSLATE_MEASURE

Format

```
SDO_LRS.TRANSLATE_MEASURE(
  geom_segment IN SDO_GEOMETRY,
  translate_m   IN NUMBER
) RETURN SDO_GEOMETRY;
```

or

```
SDO_LRS.TRANSLATE_MEASURE(
  geom_segment IN SDO_GEOMETRY,
  dim_array    IN SDO_DIM_ARRAY,
  translate_m   IN NUMBER
) RETURN SDO_GEOMETRY;
```

Description

Returns a new geometric segment by translating the original geometric segment (that is, shifting the start and end measures by a specified value).

Parameters

geom_segment

Cartographic representation of a linear feature.

dim_array

Dimensional information array corresponding to `geom_segment`, usually selected from one of the `xxx_SDO_GEOM_METADATA` views (described in [Section 2.8](#)).

translate_m

Distance measured from the start point of a geometric segment to the start point of the linear feature.

Usage Notes

This function adds `translate_m` to the start and end measures of `geom_segment`. For example, if `geom_segment` has a start measure of 50 and an end measure of 100, and if `translate_m` is 10, the returned geometric segment has a start measure of 60 and an end measure of 110, as shown in [Figure 25-1](#).

Figure 25-1 Translating a Geometric Segment

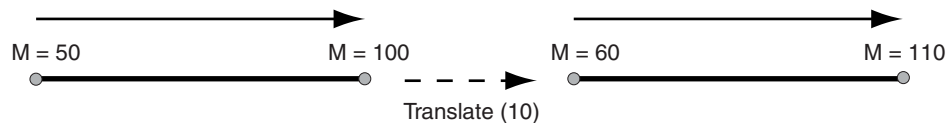

An exception is raised if `geom_segment` has an invalid geometry type or dimensionality.

The *_3D* format of this function (SDO_LRS.TRANSLATE_MEASURE_3D) is available. For information about *_3D* formats of LRS functions, see [Section 7.4](#).

Examples

The following example translates (shifts) by 10 the geometric segment representing Route 1. (This example uses the definitions from the example in [Section 7.7](#).)

```
SELECT SDO_LRS.TRANSLATE_MEASURE(a.route_geometry, m.diminfo, 10)
       FROM lrs_routes a, user_sdo_geom_metadata m
       WHERE m.table_name = 'LRS_ROUTES' AND m.column_name = 'ROUTE_GEOMETRY'
              AND a.route_id = 1;

SDO_LRS.TRANSLATE_MEASURE(A.ROUTE_GEOMETRY,M.DIMINFO,10) (SDO_GTYPE, SDO_SRID, SD
-----
SDO_GEOMETRY(3002, NULL, NULL, SDO_ELEM_INFO_ARRAY(1, 2, 1), SDO_ORDINATE_ARRAY(
2, 2, 10, 2, 4, 12, 8, 4, 18, 12, 4, 22, 12, 10, 28, 8, 10, 32, 5, 14, 37))
```

SDO_LRS.VALID_GEOM_SEGMENT

Format

```
SDO_LRS.VALID_GEOM_SEGMENT(  
    geom_segment IN SDO_GEOMETRY  
    [, dim_array IN SDO_DIM_ARRAY]  
    ) RETURN VARCHAR2;
```

Description

Checks if a geometry object is a valid geometric segment.

Parameters

geom_segment

Geometric segment to be checked for validity.

dim_array

Dimensional information array corresponding to `geom_segment`, usually selected from one of the `xxx_SDO_GEOM_METADATA` views (described in [Section 2.8](#)).

Usage Notes

This function returns TRUE if `geom_segment` is valid and FALSE if `geom_segment` is not valid.

Measure information is assumed to be stored in the last element of the `SDO_DIM_ARRAY` in the Oracle Spatial metadata.

This function only checks for geometry type and number of dimensions of the geometric segment. To further validate measure information, use the [SDO_LRS.IS_GEOM_SEGMENT_DEFINED](#) function.

The `_3D` format of this function (`SDO_LRS.VALID_GEOM_SEGMENT_3D`) is available. For information about `_3D` formats of LRS functions, see [Section 7.4](#).

Examples

The following example checks if the geometric segment representing Route 1 is valid. (This example uses the definitions from the example in [Section 7.7](#).)

```
SELECT SDO_LRS.VALID_GEOM_SEGMENT(route_geometry)  
FROM lrs_routes WHERE route_id = 1;
```

```
SDO_LRS.VALID_GEOM_SEGMENT(ROUTE_GEOMETRY)
```

```
-----  
TRUE
```

SDO_LRS.VALID_LRS_PT

Format

```
SDO_LRS.VALID_LRS_PT(
    point      IN SDO_GEOMETRY
    [, dim_array IN SDO_DIM_ARRAY]
) RETURN VARCHAR2;
```

Description

Checks if an LRS point is valid.

Parameters

point

Point to be checked for validity.

dim_array

Dimensional information array corresponding to `point`, usually selected from one of the `xxx_SDO_GEOM_METADATA` views (described in [Section 2.8](#)).

Usage Notes

This function returns TRUE if `point` is valid and FALSE if `point` is not valid.

This function checks if `point` is a point with measure information, and it checks for the geometry type and number of dimensions for the point geometry.

All LRS point data must be stored in the `SDO_ELEM_INFO_ARRAY` and `SDO_ORDINATE_ARRAY`, and cannot be stored in the `SDO_POINT` field in the `SDO_GEOMETRY` definition of the point.

The `_3D` format of this function (`SDO_LRS.VALID_LRS_PT_3D`) is available. For information about `_3D` formats of LRS functions, see [Section 7.4](#).

Examples

The following example checks if point (9,3,NULL) is a valid LRS point. (This example uses the definitions from the example in [Section 7.7](#).)

```
SELECT SDO_LRS.VALID_LRS_PT(
    SDO_GEOMETRY(3301, NULL, NULL,
        SDO_ELEM_INFO_ARRAY(1, 1, 1),
        SDO_ORDINATE_ARRAY(9, 3, NULL)),
    m.diminfo)
FROM lrs_routes a, user_sdo_geom_metadata m
WHERE m.table_name = 'LRS_ROUTES' AND m.column_name = 'ROUTE_GEOMETRY'
AND a.route_id = 1;

SDO_LRS.VALID_LRS_PT(SDO_GEOMETRY(3301,NULL,NULL,SDO_ELEM_INFO_ARRAY(1,1,1),SDO_
-----
TRUE
```

SDO_LRS.VALID_MEASURE

Format

```
SDO_LRS.VALID_MEASURE(  
    geom_segment IN SDO_GEOMETRY,  
    measure      IN NUMBER  
    ) RETURN VARCHAR2;
```

or

```
SDO_LRS.VALID_MEASURE(  
    geom_segment IN SDO_GEOMETRY,  
    dim_array    IN SDO_DIM_ARRAY,  
    measure      IN NUMBER  
    ) RETURN VARCHAR2;
```

Description

Checks if a measure falls within the measure range of a geometric segment.

Parameters

geom_segment

Geometric segment to be checked to see if *measure* falls within its measure range.

dim_array

Dimensional information array corresponding to *geom_segment*, usually selected from one of the xxx_SDO_GEOM_METADATA views (described in [Section 2.8](#)).

measure

Measure value to be checked to see if it falls within the measure range of *geom_segment*.

Usage Notes

This function returns TRUE if *measure* falls within the measure range of *geom_segment* and FALSE if *measure* does not fall within the measure range of *geom_segment*.

An exception is raised if *geom_segment* has an invalid geometry type or dimensionality.

The *_3D* format of this function (SDO_LRS.VALID_MEASURE_3D) is available. For information about *_3D* formats of LRS functions, see [Section 7.4](#).

Examples

The following example checks if 50 is a valid measure on the Route 1 segment. The function returns FALSE because the measure range for that segment is 0 to 27. For example, if the route is 27 miles long with mile markers at 1-mile intervals, there is no 50-mile marker because the last marker is the 27-mile marker. (This example uses the definitions from the example in [Section 7.7](#).)

```
SELECT SDO_LRS.VALID_MEASURE(route_geometry, 50)
       FROM lrs_routes WHERE route_id = 1;
```

```
SDO_LRS.VALID_MEASURE(ROUTE_GEOMETRY, 50)
```

```
-----  
FALSE
```

SDO_LRS.VALIDATE_LRS_GEOMETRY

Format

```
SDO_LRS.VALIDATE_LRS_GEOMETRY(  
    geom_segment IN SDO_GEOMETRY  
    [, dim_array  IN SDO_DIM_ARRAY]  
    ) RETURN VARCHAR2;
```

Description

Checks if an LRS geometry is valid.

Parameters

geom_segment

Geometric segment to be checked.

dim_array

Dimensional information array corresponding to `geom_segment`, usually selected from one of the `xxx_SDO_GEOM_METADATA` views (described in [Section 2.8](#)).

Usage Notes

This function returns TRUE if `geom_segment` is valid and one of the following errors if `geom_segment` is not valid:

- ORA-13331 (invalid LRS segment)
- ORA-13335 (measure information not defined)

The `_3D` format of this function (`SDO_LRS.VALIDATE_LRS_GEOMETRY_3D`) is available. For information about `_3D` formats of LRS functions, see [Section 7.4](#).

Examples

The following example checks if the Route 1 segment is a valid LRS geometry. (This example uses the definitions from the example in [Section 7.7](#).)

```
SELECT SDO_LRS.VALIDATE_LRS_GEOMETRY(a.route_geometry, m.diminfo)  
    FROM lrs_routes a, user_sdo_geom_metadata m  
    WHERE m.table_name = 'LRS_ROUTES' AND m.column_name = 'ROUTE_GEOMETRY'  
    AND a.route_id = 1;
```

```
SDO_LRS.VALIDATE_LRS_GEOMETRY(A.ROUTE_GEOMETRY,M.DIMINFO)
```

```
-----  
TRUE
```

SDO_MIGRATE Package (Upgrading)

The [SDO_MIGRATE.TO_CURRENT](#) subprogram described in this chapter has both procedure and function interfaces. As a procedure, it lets you upgrade spatial geometry tables from previous releases of Spatial; and as a function, it lets you upgrade a single SDO_GEOMETRY object.

This subprogram has very limited uses, as explained in the Usage Notes for its documentation.

SDO_MIGRATE.TO_CURRENT

Format (Any Object-Relational Model Implementation to Current)

```
SDO_MIGRATE.TO_CURRENT(  
    tabname      IN VARCHAR2  
    [, column_name IN VARCHAR2]);
```

or

```
SDO_MIGRATE.TO_CURRENT(  
    tabname      IN VARCHAR2,  
    column_name  IN VARCHAR2  
    [, commit_int IN NUMBER]);
```

Format (Single Object-Relational Model Geometry to Current)

```
SDO_MIGRATE.TO_CURRENT(  
    geom IN SDO_GEOMETRY,  
    dim  IN SDO_DIM_ARRAY  
    ) RETURN SDO_GEOMETRY;
```

Format (Any Relational Model Implementation to Current)

```
SDO_MIGRATE.TO_CURRENT(  
    layer      IN VARCHAR2,  
    newtabname IN VARCHAR2,  
    gidcolumn  IN VARCHAR2,  
    geocolname IN VARCHAR2,  
    layer_gtype IN VARCHAR2,  
    updateflag IN VARCHAR2);
```

Description

Upgrades data from the obsolete Spatial relational model (release 8.1.5 or earlier) to the current release, or upgrades one or more object-relational model (release 8.1.6 or later) geometries that need to be upgraded (as explained in the Usage Notes). As a procedure, `TO_CURRENT` upgrades an entire layer (all geometries in a column); as a function, `TO_CURRENT` upgrades a single geometry object, which must be of type `SDO_GEOMETRY`.

For upgrading a layer, the procedure format depends on whether you are upgrading from the Spatial relational model (release 8.1.5 or earlier) or object-relational model (release 8.1.6 or later). See the Usage Notes for the model that applies to you.

Note: This procedure applies to two-dimensional geometries only. It is not supported for three-dimensional geometries.

Parameters

tablename

Table with geometry objects.

column_name

Column in `tablename` that contains geometry objects. If `column_name` is not specified or is specified as null, the column containing geometry objects is upgraded.

commit_int

Number of geometries to upgrade before Spatial performs an internal commit operation. If `commit_int` is not specified, no internal commit operations are performed during the upgrade.

If you specify a `commit_int` value, you can use a smaller rollback segment than would otherwise be needed.

geom

Single geometry object to be upgraded to the current release.

dim

Dimensional information array for the geometry object to be upgraded. The SDO_DIM_ARRAY type is explained in [Section 2.8.3](#).

layer

Name of the layer to be upgraded.

newtablename

Name of the new table to which you are upgrading the data.

gidcolumn

Name of the column in which to store the GID from the old table.

geocolname

Name of the column in the new table where the geometry objects will be inserted.

layer_gtype

One of the following values: POINT or NOTPOINT (default).

If the layer you are upgrading is composed solely of point data, set this parameter to POINT for optimal performance; otherwise, set this parameter to NOTPOINT. If you set the value to POINT and the layer contains any nonpoint geometries, the upgrade might produce invalid data.

updateflag

One of the following values: UPDATE or INSERT (default).

If you are upgrading the layer into an existing populated attribute table, set this parameter to UPDATE; otherwise, set this parameter to INSERT.

Usage Notes for Object-Relational Model Layer and Single Geometry Upgrade

This subprogram is not needed for normal upgrades of Oracle Spatial. It is sometimes needed if spatial data is loaded using a third-party loader and if the resulting geometries have the wrong orientation or invalid ETYPE or GTYPE values. For information about using this subprogram as part of the recommended procedure for loading and validating spatial data, see [Section 4.3](#).

This subprogram upgrades the specified geometry or all geometry objects in the specified layer so that their SDO_GTYPE and SDO_ETYPE values are in the format of the current release:

- SDO_GTYPE values of 4 digits are created, using the format (*DLTT*) shown in [Table 2–1](#) in [Section 2.2.1](#).
- SDO_ETYPE values are as discussed in [Section 2.2.4](#).

Geometries are ordered so that exterior rings are followed by their interior rings, and coordinates are saved in the correct rotation (counterclockwise for exterior rings, and clockwise for interior rings).

Usage Notes for Relational Model Upgrade

If you are upgrading from the Spatial relational model (release 8.1.5 or earlier), consider the following when using this procedure:

- The new table must be created before you call this procedure.
- If the data to be upgraded is geodetic, the tolerance value (SDO_TOLERANCE column value in the *<layername>_SDODIM* table or view) must be expressed in decimal degrees (for example, 0.00000005).
- The procedure converts geometries from the relational model to the object-relational model.
- A commit operation is performed by this procedure.
- If any of the upgrade steps fails, nothing is upgraded for the layer.
- *layer* is the underlying layer name, without the *_SDOGEOM* suffix.
- The old SDO_GID is stored in *gidcolumn*.
- SDO_GTYPE values of 4 digits are created, using the format (*DLTT*) shown in [Table 2–1](#) in [Section 2.2.1](#).
- SDO_ETYPE values are created, using the values discussed in [Section 2.2.4](#).
- The procedure orders geometries so that exterior rings are followed by their interior rings, and it saves coordinates in the correct rotation (counterclockwise for exterior rings, and clockwise for interior rings).

Examples

The following example changes the definitions of geometry objects in the *ROADS* table from the format of a release later than 8.1.5 to the format of the current release.

```
EXECUTE SDO_MIGRATE.TO_CURRENT('ROADS');
```

SDO_OLS Package (OpenLS)

The MDSYS.SDO_OLS package contains subprograms for Spatial OpenLS support.

To use the subprograms in this chapter, you must understand the conceptual and usage information about OpenLS in [Chapter 14](#).

[Table 27-1](#) lists the OpenLS subprograms.

Table 27-1 Subprograms for OpenLS Support

Subprogram	Description
SDO_OLS.MakeOpenLSClobRequest	Submits an OpenLS request using a CLOB object, and returns the result as a CLOB object.
SDO_OLS.MakeOpenLSRequest	Submits an OpenLS request using an XMLType object, and returns the result as an XMLType object.

The rest of this chapter provides reference information on the subprograms, listed in alphabetical order.

SDO_OLS.MakeOpenLSClobRequest

Format

```
SDO_OLS.MakeOpenLSClobRequest(
    request IN CLOB
) RETURN CLOB;
```

Description

Submits an OpenLS request using a CLOB object, and returns the result as a CLOB object.

Parameters

request

OpenLS request in the form of a CLOB object.

Usage Notes

To specify the input request as an XMLType object to return an XMLType object, use the [SDO_OLS.MakeOpenLSRequest](#) function.

For information about OpenLS support, see [Chapter 14](#).

Examples

The following example requests the nearest business, in a specified category (that is, with specified `SIC_code` value), to a specified location (longitude: -122.4083257, latitude: 37.788208).

```
DECLARE
    request CLOB;
    result CLOB;
BEGIN
    request := TO_CLOB(
'<?xml version="1.0" encoding="UTF-8"?>
<XLS xmlns="http://www.opengis.net/xls" xmlns:gml="http://www.opengis.net/gml"
  xmlns:xsi="http://www.w3.org/2001/XMLSchema-instance" version="1.1">
  <RequestHeader clientName="someName" clientPassword="password"/>
  <Request requestID="123" maximumResponses="100" version="1.1"
    methodName="DirectoryRequest">
    <DirectoryRequest>
    <POILocation>
    <Nearest nearestCriterion="Proximity">
    <Position>
    <gml:Point xmlns:gml="http://www.opengis.net/gml">
    <gml:pos dimension="2" srsName="4326">-122.4083257 37.788208</gml:pos>
    </gml:Point>
    </Position>
    </Nearest>
    </POILocation>
    <POIProperties>
    <POIProperty name="SIC_code" value="1234567890"/>
    </POIProperties>
    </DirectoryRequest>
  </Request>
```

```
</XLS>');  
  
result := SDO_OLS.makeOpenLSClobRequest(request);  
  
END;  
/
```

SDO_OLS.MakeOpenLSRequest

Format

```
SDO_OLS.MakeOpenLSRequest(
    request IN XMLTYPE
) RETURN XMLTYPE;
```

Description

Submits an OpenLS request using an XMLType object, and returns the result as an XMLType object.

Parameters

request

OpenLS request in the form of an XMLType object.

Usage Notes

To specify the input request as a CLOB and to return a CLOB, use the [SDO_OLS.MakeOpenLSClobRequest](#) function.

For information about OpenLS support, see [Chapter 14](#).

Examples

The following example requests the nearest business, in a specified category (that is, with specified SIC_code value), to a specified location (longitude: -122.4083257, latitude: 37.788208).

```
SELECT SDO_OLS.makeOpenLSRequest (XMLTYPE (
'<?xml version="1.0" encoding="UTF-8"?>
<XLS xmlns="http://www.opengis.net/xls" xmlns:gml="http://www.opengis.net/gml"
  xmlns:xsi="http://www.w3.org/2001/XMLSchema-instance" version="1.1">
  <RequestHeader clientName="someName" clientPassword="password"/>
  <Request requestID="123" maximumResponses="100" version="1.1"
    methodName="DirectoryRequest">
    <DirectoryRequest>
      <POILocation>
        <Nearest nearestCriterion="Proximity">
          <Position>
            <gml:Point xmlns:gml="http://www.opengis.net/gml">
              <gml:pos dimension="2" srsName="4326">-122.4083257 37.788208</gml:pos>
            </gml:Point>
          </Position>
        </Nearest>
      </POILocation>
      <POIProperties>
        <POIProperty name="SIC_code" value="1234567890"/>
      </POIProperties>
    </DirectoryRequest>
  </Request>
</XLS>')) "OpenLS Response" FROM DUAL;
```

SDO_PC_PKG Package (Point Clouds)

This chapter contains descriptions of the point cloud subprograms shown in [Table 28-1](#).

Table 28-1 *Point Cloud Subprograms*

Subprogram	Description
SDO_PC_PKG.CLIP_PC	Performs a clip operation on a point cloud.
SDO_PC_PKG.CREATE_PC	Creates a point cloud using the points specified in the <code>inptable</code> parameter.
SDO_PC_PKG.DROP_DEPENDENCIES	Drops the dependencies between a point cloud block table and a specified base table and column.
SDO_PC_PKG.INIT	Initializes a point cloud.
SDO_PC_PKG.TO_GEOMETRY	Returns a geometry object representing all or part of a point cloud.

To use the subprograms in this package, you must understand the main concepts related to three-dimensional geometries, including the use of point clouds to model solids. [Section 1.11](#) describes support for three-dimensional geometries, [Section 1.11.2](#) describes the use of p[oint clouds to model solids, and [Section 2.6](#) describes data types related to point clouds.

SDO_PC_PKG.CLIP_PC

Format

```
SDO_PC_PKG.CLIP_PC(  
    inp          IN SDO_PC,  
    ind_dimqry   IN SDO_GEOMETRY,  
    other_dimqry IN SDO_MBR,  
    qry_min_res  IN NUMBER,  
    qry_max_res  IN NUMBER,  
    blkno       IN NUMBER DEFAULT NULL  
    ) RETURN SDO_PC_BLK_TYPE;
```

Description

Performs a clip operation on a point cloud.

Parameters

inp

Point cloud on which to perform the clip operation.

ind_dimqry

For querying the indexed dimensions of the point cloud: window from which to select objects to be returned; typically a polygon for two-dimensional geometries or a frustum for three-dimensional geometries.

other_dimqry

For querying the nonindexed dimensions of the point cloud: window from which to select objects to be returned; typically a polygon for two-dimensional geometries or a frustum for three-dimensional geometries. The nonindexed dimensions are those that are included in the total dimensionality but are not indexed. For an explanation of index dimensionality and total dimensionality, see the explanation of the `pc_tot_dimensions` parameter of the [SDO_PC_PKG.INIT](#) function.

The `SDO_MBR` type is defined as (`LOWER_LEFT` `SDO_VPOINT_TYPE`, `UPPER_RIGHT` `SDO_VPOINT_TYPE`) and `SDO_V_POINT_TYPE` is defined as `VARRAY (64) OF NUMBER`.

qry_min_res

Minimum resolution value. Objects in `qry` with resolutions equal to or greater than `qry_min_res` and less than or equal to `qry_max_res` are returned by the clip operation.

qry_max_res

Maximum resolution value. Objects in `qry` with resolutions equal to or greater than `qry_min_res` and less than or equal to `qry_max_res` are returned by the clip operation.

blkid

Block ID number of the block to which to restrict the objects returned by the clip operation. If this parameter is null, all objects that satisfy the other parameters are returned.

Usage Notes

This function returns points from a point cloud that are within a specified query window and that satisfy any other requirements specified by the parameters. A common use of this function is to perform queries on point clouds. You can maximize the performance of a point cloud query by minimizing the number of objects that the function needs to consider for the operation.

The SDO_PC and SDO_PC_BLK_TYPE data types are described in [Section 2.6](#).

[Section 1.11.2](#) describes how to use point clouds to model solids.

Examples

The following example performs a clip operation on a point cloud. It is taken from the `sdo_pc.sql` example program, which is under `$ORACLE_HOME/md/demo/examples/PointCloud/plsql/` if you installed the files from the Oracle Database Examples media (see *Oracle Database Examples Installation Guide*).

```

. . .
declare
  inp sdo_pc;
begin
  select pc INTO inp  from base where rownum=1;
  insert into restst
  select * from
    table(sdo_pc_pkg.clip_pc
      (
        inp, -- Input point cloud object
        sdo_geometry(2003, 8307, null,
          sdo_elem_info_array(1, 1003, 3),
          sdo_ordinate_array(-175.86157, -14.60521, 0,0)), -- Query
        null, null, null));
end;
/
. . .

```

SDO_PC_PKG.CREATE_PC

Format

```
SDO_PC_PKG.CREATE_PC(
    inp          IN SDO_PC,
    inptable    IN VARCHAR2,
    clstPcdataTbl IN VARCHAR2 DEFAULT NULL);
```

Description

Creates a point cloud using the points specified in the `inptable` parameter.

Parameters

inp

SDO_PC object to be used. This object must have been created by the [SDO_PC_PKG.INIT](#) function.

inptable

Name of the table or view containing the input point cloud data. This table or view should have the following columns:

- RID (VARCHAR2(24)): Unique ID for each point
- VAL_D1 (NUMBER): Ordinate in dimension 1
- VAL_D2 (NUMBER): Ordinate in dimension 2
- ...
- VAL_Dn (NUMBER): Ordinate in dimension *n*, where *n* is the highest-numbered dimension. *n* should match the `pc_tot_dimensions` parameter value in the call to the [SDO_PC_PKG.INIT](#) function when the point cloud was initialized.

clstPcdataTbl

Name of the table for storing the resulting point data. If you do not specify a value, this table is not created. For more information about the table, see the Usage Notes.

Usage Notes

The first few dimensions of the point cloud are indexed and can later be searched using the [SDO_PC_PKG.CLIP_PC](#) function. The exact number of dimensions to index is determined by the dimensionality of the point cloud extent in the initialized point cloud object, specifically: `inp.pc_extent.sdo_gtype/1000`

If you specify a view name in the `inptable` parameter, the query `SELECT ROWID FROM <view-name>` must not return any errors.

If you specify a table name in the `clstPcdataTbl` parameter, the table must exist and have the following columns:

- PTN_ID (NUMBER)
- POINT_ID (NUMBER)
- RID (VARCHAR2(24)): Unique ID for each point
- VAL_D1 (NUMBER): Ordinate in dimension 1

- VAL_D2 (NUMBER): Ordinate in dimension 2
- ...
- VAL_Dn (NUMBER): Ordinate in dimension *n*, where *n* is the highest-numbered dimension. *n* should match the `pc_tot_dimensions` parameter value in the call to the `SDO_PC_PKG.INIT` function when the point cloud was initialized.

If a value is specified for the `clstPcdataTbl` parameter, this function populates the table by assigning appropriate values for `PTN_ID` and `POINT_ID` and by copying the values from the `inptable` table or view for other attributes. This table can be created as an index organized table. It can be used in applications for searching using SQL queries on dimensions other than those reflected in the index dimensionality. (For an explanation of index dimensionality and total dimensionality, see the explanation of the `pc_tot_dimensions` parameter of the `SDO_PC_PKG.INIT` function.)

The `SDO_PC` and `SDO_PC_BLK_TYPE` data types are described in [Section 2.6](#).

[Section 1.11.2](#) describes how to use point clouds to model solids.

Examples

The following example creates a point cloud. It is taken from the `sdo_pc.sql` example program, which is under `$ORACLE_HOME/md/demo/examples/PointCloud/plsql/` if you installed the files from the Oracle Database Examples media (see *Oracle Database Examples Installation Guide*).

```

. . .
-- Create the blocks for the point cloud.
sdo_pc_pkg.create_pc(
  pc,          -- Initialized PointCloud object
  'INPTAB',   -- Name of input table to ingest into the pointcloud
  'RES'       -- Name of output table that stores the points (with ptn_id,pt_id)
);
. . .

```

SDO_PC_PKG.DROP_DEPENDENCIES

Format

```
SDO_PC_PKG.DROP_DEPENDENCIES(  
    basetable IN VARCHAR2,  
    col       IN VARCHAR2);
```

Description

Drops the dependencies between a point cloud block table and a specified base table and column.

Parameters

basetable

Name of a base table that was specified (in the `basetable` parameter of the [SDO_PC_PKG.INIT](#) function) when the point cloud was initialized.

col

Name of a column in base table that was specified in the `basecol` parameter of the [SDO_PC_PKG.INIT](#) function.

Usage Notes

This procedure truncates the point cloud block table and removes the association between the block table and the base table and column combination.

After you execute this procedure, you can drop the point cloud block table or associate the table with another base table and column combination. For more information, see the Usage Notes for the [SDO_PC_PKG.INIT](#) function.

Examples

The following example drops the dependencies between a point cloud block table and a base table and column named `BASE` and `PC`, respectively.

```
. . .  
declare  
begin  
    mdsys.sdo_pc_pkg.drop_dependencies('BASE', 'PC');  
end;  
/
```

SDO_PC_PKG.GET_PT_IDS

Format

```
SDO_PC_PKG.GET_PT_IDS(
    pts          IN BLOB,
    num_pts     IN NUMBER,
    pc_tot_dim  IN NUMBER,
    blk_domain  IN SDO_ORGSCL_TYPE DEFAULT NULL,
) RETURN SDO_NUMBER_ARRAY;
```

Description

Returns the block ID and point ID values of the points in a block in a point cloud.

Parameters

pts

Binary large object (BLOB) containing the point cloud block.

num_pts

Number of points in the point cloud block. For a point cloud block, the number of points is stored in the NUM_POINTS column of the point cloud block table, which is described in [Table 2-7](#) in [Section 2.6.1](#).

pc_tot_dim

Number of dimensions for the points in the point cloud block.

blk_domain

(Not currently used.)

Usage Notes

This function returns an SDO_NUMBER_ARRAY object. The array contains multiple pairs of numbers, with each pair identifying the block ID and point ID of a point. For any specific call to this function, the block ID values associated with all points in the returned array will be the same. The SDO_NUMBER_ARRAY type is defined as VARRAY(1048576) OF NUMBER.

[Section 1.11.2](#) describes how to use point clouds to model solids.

Examples

The following example returns the block ID and point ID values of points in a point cloud block. It is taken from the `sdo_pc.sql` example program, which is under `$ORACLE_HOME/md/demo/examples/PointCloud/plsql/` if you installed the files from the Oracle Database Examples media (see *Oracle Database Examples Installation Guide*).

```
SELECT SDO_PC_PKG.GET_PT_IDS (
    a.points,    -- LOB containing the points
    a.num_points, -- # of points in the LOB
    3 -- Total dimensionality of the points in the LOB
) FROM restst a WHERE num_points >0;
```

SDO_PC_PKG.INIT

Format

```
SDO_PC_PKG.INIT(  
    basetable      IN VARCHAR2,  
    basecol        IN VARCHAR2,  
    blktable       IN VARCHAR2,  
    ptn_params     IN VARCHAR2,  
    pc_extent      IN SDO_GEOMETRY,  
    pc_tol         IN NUMBER DEFAULT 0.00000000000005,  
    pc_tot_dimensions IN NUMBER DEFAULT 2,  
    pc_domain      IN SDO_ORGSCL_TYPE DEFAULT NULL,  
    pc_val_attr_tables IN SDO_STRING_ARRAY DEFAULT NULL,  
    pc_other_attrs  IN XMLTYPE DEFAULT NULL,  
) RETURN SDO_PC;
```

Description

Initializes a point cloud by creating an SDO_PC object.

Parameters

basetable

Name of the base table containing a column of type SDO_PC.

basecol

Name of the column of type SDO_PC in the base table.

blktable

Name of the point cloud block table, which is used for storing the blocks of point cloud. This table must exist, and must have been created by a statement in the following form: `CREATE TABLE <table-name> AS select * from mdsys.sdo_pc_blk_table;`

Each point cloud block table can only be associated with only one basetable and basecol combination.

ptn_params

Parameters for partitioning the point cloud, specified as a quoted string with keywords delimited by commas. For example: `'blk_capacity=1000,work_tablespace=my_work_ts'`. If this parameter is null, the point cloud is not partitioned. The following keywords are permitted:

- `blk_capacity=n`, where *n* is the maximum number of rows in each partition. The default value is 5000. If specified, must be a number greater than or equal to 50.
- `work_tablespace=x`, where *x* is the name of the tablespace in which to create temporary tables during the partitioning operations.

pc_extent

SDO_GEOMETRY object representing the spatial extent of the point cloud (the minimum bounding object enclosing all objects in the point cloud). This parameter must not be null.

For geodetic data, this geometry must have two dimensions; otherwise, it can have up to four dimensions. The dimensionality of this geometry is used as the minimum value permitted for the `pc_tot_dimensions` parameter, as explained in the description of that parameter.

pc_tol

Tolerance value for objects in the point cloud. (For information about spatial tolerance, see Section 1.5.5.) If this parameter is null, the default value is 0.0000000000005.

pc_tot_dimensions

A number specifying the *total dimensionality* of the point cloud object. For each point in the point cloud blocks, `pc_tot_dimensions` ordinates (values) are stored.

The total dimensionality must be greater than or equal to the index dimensionality, which is the number of dimensions in the `pc_extent` geometry. Specifying total dimensionality greater than index dimensionality enables necessary nonspatial attributes to be retrieved in the same fetch operation with spatial data. The maximum total dimensionality value is 8. The default value for this parameter is 2.

pc_domain

(Not currently used.)

pc_val_attr_tables

SDO_STRING_ARRAY object specifying the names of any value attribute tables for the point cloud. If this parameter is null, the point cloud has no associated value attribute tables. Type SDO_STRING_ARRAY is defined as VARRAY(1048576) OF VARCHAR2(32).

pc_other_attrs

XMLTYPE object specifying any other attributes of the point cloud. If this parameter is null, the point cloud has no other attributes.

Usage Notes

After you use this function to create an SDO_PC object, you can create a point cloud by specifying this object as input to the [SDO_PC_PKG.CREATE_PC](#) procedure.

The SDO_PC data type is described in [Section 2.5](#).

[Section 1.11.2](#) describes how to use point clouds to model solids.

After you use this function, the `blktable` table is kept in synchronization with the base table. For example, if a row is deleted from the `basetable`, the corresponding blocks of the point cloud object in that row are also deleted from the block table; and if the base table base table is truncated, the block table is truncated also.

The block table can be dropped only after either of the following occurs: the base table is dropped, or the [SDO_PC_PKG.DROP_DEPENDENCIES](#) procedure is executed.

Examples

The following example initializes a point cloud by creating an SDO_PC object, and it displays the ID of the object. It is taken from the `sdo_pc.sql` example program, which is under `$ORACLE_HOME/md/demo/examples/PointCloud/plsql/` if you

installed the files from the Oracle Database Examples media (see *Oracle Database Examples Installation Guide*)a.

```
. . .
declare
  pc sdo_pc;
begin
  -- Initialize the point cloud object.
  pc := sdo_pc_pkg.init(
    'BASE', -- Table that has the SDO_POINT_CLOUD column defined
    'PC',   -- Column name of the SDO_POINT_CLOUD object
    'BLKTAB', -- Table to store blocks of the point cloud
    'blk_capacity=1000', -- max # of points per block
    mdsys.sdo_geometry(2003, 8307, null,
      mdsys.sdo_elem_info_array(1,1003,3),
      mdsys.sdo_ordinate_array(-180, -90, 180, 90)), -- Extent
    0.5, -- Tolerance for point cloud
    3, -- Total number of dimensions
    null);
. . .
```

SDO_PC_PKG.TO_GEOMETRY

Format

```
SDO_PC_PKG.TO_GEOMETRY(
    pts      IN BLOB,
    num_pts  IN NUMBER,
    tin_tot_dim IN NUMBER,
    srid     IN NUMBER DEFAULT NULL,
    blk_domain IN SDO_ORGSCL_TYPE DEFAULT NULL
) RETURN SDO_GEOMETRY;
```

Description

Returns a geometry object representing all or part of a point cloud.

Parameters

pts

BLOB containing the points.

num_pts

Maximum number of points to be included in the resulting geometry.

tin_tot_dim

Number of spatial dimensions defined for the data.

srid

Spatial reference (coordinate system) ID associated with the data. If this parameter is null, no SRID value is associated with the data.

blk_domain

(Not currently used.)

Usage Notes

This function returns a single multipoint SDO_GEOMETRY object that represents all point geometries in the `pts` parameter. For example, the points could reflect the result of a clip operation or the contents of an entire block.

[Section 1.11.2](#) describes how to use point clouds to model solids.

Examples

The following example returns a multipoint collection geometry object representing a point cloud. It is taken from the `sdo_pc.sql` example program, which is under `$ORACLE_HOME/md/demo/examples/PointCloud/plsql/` if you installed the files from the Oracle Database Examples media (see *Oracle Database Examples Installation Guide*).

```
. . .
-- Return points in blk_id of the point cloud as a multipoint collection.
select sdo_pc_pkg.to_geometry(
            a.points,    -- point LOB
```

```
a.num_points, -- # of points in the LOB  
3, -- total dimensionality  
8307 -- SRID  
) from blktab a where blk_id=0;
```

. . .

SDO_SAM Package (Spatial Analysis and Mining)

The MDSYS.SDO_SAM package contains subprograms for spatial analysis and data mining.

To use the subprograms in this chapter, you must understand the conceptual information about spatial analysis and data mining in [Chapter 8](#).

Note: SDO_SAM subprograms are supported for two-dimensional geometries only. They are not supported for three-dimensional geometries.

[Table 29–1](#) lists the spatial analysis and mining subprograms.

Table 29–1 Subprograms for Spatial Analysis and Mining

Function	Description
SDO_SAM.AGGREGATES_FOR_GEOMETRY	Computes the thematic aggregate for a geometry.
SDO_SAM.AGGREGATES_FOR_LAYER	Computes thematic aggregates for a layer of geometries.
SDO_SAM.BIN_GEOMETRY	Computes the most-intersecting tile for a geometry.
SDO_SAM.BIN_LAYER	Assigns each location (and the corresponding row) in a data mining table to a spatial bin.
SDO_SAM.COLOCATED_REFERENCE_FEATURES	Performs a partial predicate-based join of tables, and materializes the join results into a table.
SDO_SAM.SIMPLIFY_GEOMETRY	Simplifies a geometry.
SDO_SAM.SIMPLIFY_LAYER	Simplifies a geometry layer.
SDO_SAM.SPATIAL_CLUSTERS	Computes clusters using the existing R-tree index, and returns a set of SDO_REGION objects where the geometry column specifies the boundary of each cluster and the geometry_key value is set to null.
SDO_SAM.TILED_AGGREGATES	Tiles aggregates for a domain. For each tile, computes the intersecting geometries from the theme table; the values in the aggr_col_string column are weighted proportionally to the area of the intersection, and aggregated according to aggr_col_string.

Table 29–1 (Cont.) Subprograms for Spatial Analysis and Mining

Function	Description
SDO_SAM.TILED_BINS	Tiles a two-dimensional space and returns geometries corresponding to those tiles.

The rest of this chapter provides reference information on the spatial analysis and mining subprograms, listed in alphabetical order.

SDO_SAM.AGGREGATES_FOR_GEOMETRY

Format

```
SDO_SAM.AGGREGATES_FOR_GEOMETRY(  
    theme_name    IN VARCHAR2,  
    theme_colname IN VARCHAR2,  
    aggr_type_string IN VARCHAR2,  
    aggr_col_string IN VARCHAR2,  
    geom          IN SDO_GEOMETRY,  
    dst_spec      IN VARCHAR2 DEFAULT NULL  
) RETURN NUMBER;
```

Description

Computes the thematic aggregate for a geometry.

Parameters

theme_name

Name of the theme table.

theme_colname

Name of the geometry column in `theme_name`.

aggr_type_string

Any Oracle SQL aggregate function that accepts one or more numeric values and computes a numeric value, such as `SUM`, `MIN`, `MAX`, or `AVG`.

aggr_col_string

Name of a column in `theme_name` on which to compute aggregate values, as explained in the Usage Notes. An example might be a `POPULATION` column.

geom

Geometry object.

dst_spec

A quoted string specifying either a distance buffer or a number of nearest neighbor geometries to consider. See the Usage Notes for an explanation of the format and meaning.

Usage Notes

For a specific geometry, this function identifies the geometries in the `theme_name` table, finds their intersection ratio, multiplies the specified aggregate using this intersection ratio, and aggregates it for the geometry. Specifically, for all rows of the `theme_name` table that intersect with the specified geometry, it returns the value from the following function:

```
aggr_type_string(aggr_col_string * proportional_area_of_intersection(geometry,  
theme_name.theme_colname))
```

The `theme_colname` column must have a spatial index defined on it. For best performance, insert simplified geometries into this column.

The `dst_spec` parameter, if specified, is a quoted string that must contain either of the following:

- The `distance` keyword and optionally the `unit` keyword (unit of measurement associated with the distance value), to specify a buffer around the geometry. For example, `'distance=2 unit=km'` specifies a 2-kilometer buffer around the input geometry. If `dst_spec` is not specified, no buffer is used.

If the `unit` keyword is specified, the value must be an `SDO_UNIT` value from the `MDSYS.SDO_DIST_UNITS` table (for example, `'unit=km'`). If the `unit` keyword is not specified, the unit of measurement associated with the geometry is used. See [Section 2.10](#) for more information about unit of measurement specification.

- The `sdo_num_res` keyword, to specify the number of nearest-neighbor geometries to consider, without considering proportional coverage. For example, `'sdo_num_res=5'` could be used in a query that asks for the populations of the five cities that are nearest to a specified point.

Examples

The following example computes the thematic aggregate for an area with a 3-mile radius around a specified point geometry. In this case, the total population of the area is computed based on the proportion of the circle's area within different counties, assuming uniform distribution of population within the counties.

```
SELECT sdo_sam.agggregates_for_geometry(  
  'GEOD_COUNTIES', 'GEOM',  
  'sum', 'totpop',  
  SDO_GEOMETRY(2001, 8307,  
    SDO_POINT_TYPE(-73.943849, 40.6698, NULL),  
    NULL, NULL),  
  'distance=3 unit=mile')  
FROM DUAL a ;
```

SDO_SAM.AGGREGATES_FOR_LAYER

Format

```
SDO_SAM.AGGREGATES_FOR_LAYER(
    theme_name    IN VARCHAR2,
    theme_colname IN VARCHAR2,
    aggr_type_string IN VARCHAR2,
    aggr_col_string IN VARCHAR2,
    tablename     IN VARCHAR2,
    colname       IN VARCHAR2,
    dst_spec      IN VARCHAR2 DEFAULT NULL
) RETURN SDO_REGAGGRSET;
```

Description

Computes thematic aggregates for a layer of geometries.

Parameters

theme_name

Name of the theme table.

theme_colname

Name of the geometry column in `theme_name`.

aggr_type_string

Any Oracle SQL aggregate function that accepts one or more numeric values and computes a numeric value, such as `SUM`, `MIN`, `MAX`, or `AVG`.

aggr_col_string

Name of a column in `theme_name` on which to compute aggregate values, as explained in the Usage Notes. An example might be a `POPULATION` column.

tablename

Name of the data mining table.

colname

Name of the column in `tablename` that holds the geometries.

dst_spec

A quoted string specifying either a distance buffer or a number of nearest neighbor geometries to consider. See the Usage Notes for the [SDO_SAM.AGGREGATES_FOR_GEOMETRY](#) function in this chapter for an explanation of the format and meaning.

Usage Notes

For each geometry in `tablename`, this function identifies the geometries in the `theme_name` table, finds their intersection ratio, multiplies the specified aggregate using this intersection ratio, and aggregates it for each geometry in `tablename`. Specifically, for all rows of the `theme_name` table, it returns the value from the following function:

```
aggr_type_string(aggr_col_string * proportional_area_of_intersection(geometry,
theme_name.theme_colname))
```

This function returns an object of type SDO_REGAGGRSET. The SDO_REGAGGRSET object type is defined as:

TABLE OF SDO_REGAGGR

The SDO_REGAGGR object type is defined as:

Name	Null?	Type
REGION_ID		VARCHAR2(24)
GEOMETRY		MDSYS.SDO_GEOMETRY
AGGREGATE_VALUE		NUMBER

The theme_colname column must have a spatial index defined on it. For best performance, insert simplified geometries into this column.

Examples

The following example computes the thematic aggregates for all geometries in a table named TEST_TAB for an area with a 3-mile radius around a specified point geometry. In this case, the total population of each area is computed based on the proportion of the circle's area within different counties, assuming uniform distribution of population within the counties.

```
SELECT a.aggregate_value FROM TABLE(sdo_sam.aggregates_for_layer(
'GEOD_COUNTIES', 'GEOM', 'SUM', TOTPOP', TEST_TAB', 'GEOM'
'distance=3 unit=mile')) a;
```

SDO_SAM.BIN_GEOMETRY

Format

```
SDO_SAM.BIN_GEOMETRY(  
    geom          IN SDO_GEOMETRY,  
    tol          IN SDO_DIM_ARRAY,  
    bin_tablename IN VARCHAR2,  
    bin_colname  IN VARCHAR2  
    ) RETURN NUMBER;
```

or

```
SDO_SAM.BIN_GEOMETRY(  
    geom          IN SDO_GEOMETRY,  
    dim          IN SDO_DIM_ARRAY,  
    bin_tablename IN VARCHAR2,  
    bin_colname  IN VARCHAR2  
    ) RETURN NUMBER;
```

Description

Computes the most-intersecting tile for a geometry.

Parameters

geom

Geometry for which to compute the bin.

tol

Tolerance value (see [Section 1.5.5](#)).

dim

Dimensional array for the table that holds the geometries for the bins.

bin_tablename

Name of the table that holds the geometries for the bins.

bin_colname

Column in `bin_tablename` that holds the geometries for the bins.

Usage Notes

This function returns the bin that intersects most with the specified geometry. If multiple bins intersect to the same extent with the specified geometry, the bin with the smallest area is returned.

To perform this operation on all rows in the data mining table, using the specified `bin_tablename`, you can use the [SDO_SAM.BIN_LAYER](#) procedure.

Examples

The following example computes the bin for a specified geometry.

```
SELECT sdo_sam.bin_geometry(a.geometry, 0.0000005, 'BINTBL', 'GEOMETRY')
   FROM poly_4pt a, user_sdo_geom_metadata b
   WHERE b.table_name='POLY_4PT' AND a.gid=1;
```

```
SDO_SAM.BIN_GEOMETRY(A.GEOMETRY,0.0000005,'BINTBL','GEOMETRY')
```

```
-----
```

43

1 row selected.

SDO_SAM.BIN_LAYER

Format

```
SDO_SAM.BIN_LAYER(  
    tablename      IN VARCHAR2,  
    colname        IN VARCHAR2,  
    bin_tablename  IN VARCHAR2,  
    bin_colname    IN VARCHAR2,  
    bin_id_colname IN VARCHAR2,  
    commit_interval IN NUMBER DEFAULT 20);
```

Description

Assigns each location (and the corresponding row) in a data mining table to a spatial bin.

Parameters

tablename

Name of the data mining table.

colname

Name of the column in `table_name` that holds the location coordinates.

bin_tablename

Name of the table that contains information (precomputed for the entire two-dimensional space) about the spatial bins.

bin_colname

Column in `bin_tablename` that holds the geometries for the bins.

bin_id_colname

Name of the column in the data mining table that holds the bin ID value of each geometry added to a bin. (Each affected row in the data mining table is updated with the ID value of the bin geometry in `bin_tablename`.)

commit_interval

Number of bin insert operations to perform before Spatial performs an internal commit operation. If `commit_interval` is not specified, a commit is performed after every 20 insert operations.

Usage Notes

This procedure computes the most-intersecting tile for each geometry in a specified layer using the bins in `bin_tablename`. The bin ID value for each geometry is added in `bin_id_colname`.

Using this procedure achieves the same result as using the [SDO_SAM.BIN_GEOMETRY](#) function on each row in the data mining table, using the specified `bin_tablename`.

Examples

The following example assigns each GEOMETRY column location and corresponding row in the POLY_4PT_TEMP data mining table to a spatial bin, and performs an internal commit operation after each bin table insertion.

```
CALL SDO_SAM.BIN_LAYER('POLY_4PT_TEMP', 'GEOMETRY', 'BINTBL', 'GEOMETRY', 'BIN_ID', 1);
```

SDO_SAM.COLOCATED_REFERENCE_FEATURES

Format

```
SDO_SAM.COLOCATED_REFERENCE_FEATURES(
  theme_tablename      IN VARCHAR2,
  theme_colname        IN VARCHAR2,
  theme_predicate      IN VARCHAR2,
  tablename            IN VARCHAR2,
  colname              IN VARCHAR2,
  ref_predicate        IN VARCHAR2,
  dst_spec             IN VARCHAR2,
  result_tablename    IN VARCHAR2,
  commit_interval     IN NUMBER DEFAULT 100);
```

Description

Performs a partial predicate-based join of tables, and materializes the join results into a table.

Parameters

theme_tablename

Name of the table with which to join `tablename`.

theme_colname

Name of the geometry column in `theme_tablename`.

theme_predicate

Qualifying WHERE clause predicate to be applied to `theme_tablename`.

tablename

Name of the data mining table.

colname

Name of the column in `tablename` that holds the location coordinates.

ref_predicate

Qualifying WHERE clause predicate to be applied to `tablename`. Must be a single table predicate, such as `'country_code=10'`.

dst_spec

A quoted string containing a distance value and optionally a unit value for a buffer around the geometries. See the Usage Notes for an explanation of the format and meaning.

result_tablename

The table in which materialized join results are stored. This table must have the following definition: `(tid NUMBER, rid1 VARCHAR2(24), rid2 VARCHAR2(24))`

commit_interval

Number of internal join operations to perform before Spatial performs an internal commit operation. If `commit_interval` is not specified, a commit is performed after every 100 internal join operations.

Usage Notes

This procedure materializes each pair of rowids returned from a predicate-based join operation, and stores them in the `rid1`, `rid2` columns of `result_tablename`. The `tid` is a unique generated "interaction" number corresponding to each `rid1` value.

The `dst_spec` parameter, if specified, is a quoted string containing the `distance` keyword and optionally the `unit` keyword (unit of measurement associated with the distance value), to specify a buffer around the geometry. For example, `'distance=2 unit=km'` specifies a 2-kilometer buffer around the input geometry. If `dst_spec` is not specified, no buffer is used.

If the `unit` keyword is specified, the value must be an `SDO_UNIT` value from the `MDSYS.SDO_DIST_UNITS` table (for example, `'unit=KM'`). If the `unit` keyword is not specified, the unit of measurement associated with the geometry is used. See [Section 2.10](#) for more information about unit of measurement specification.

Examples

The following example identifies cities with a 1990 population (POP90 column value) greater than 120,000 that are located within 20 kilometers of interstate highways (GEOM column in the GEOD_INTERSTATES table). It stores the results in a table named COLOCATION_TABLE, and performs an internal commit operation after each 20 internal operations.

```
EXECUTE SDO_SAM.COLOCATED_REFERENCE_FEATURES(  
  'geod_cities', 'location', 'pop90 > 120000',  
  'geod_interstates', 'geom', null,  
  'distance=20 unit=km', 'colocation_table', 20);
```

SDO_SAM.SIMPLIFY_GEOMETRY

Format

```
SDO_SAM.SIMPLIFY_GEOMETRY(  
    geom            IN SDO_GEOMETRY,  
    dim            IN SDO_DIM_ARRAY,  
    pct_area_change_limit IN NUMBER DEFAULT 2  
    ) RETURN SDO_GEOMETRY;
```

or

```
SDO_SAM.SIMPLIFY_GEOMETRY(  
    geom            IN SDO_GEOMETRY,  
    tol            IN NUMBER,  
    pct_area_change_limit IN NUMBER DEFAULT 2  
    ) RETURN SDO_GEOMETRY;
```

Description

Simplifies a geometry.

Parameters

geom

Geometry to be simplified.

dim

Dimensional array for the geometry to be simplified.

tol

Tolerance value (see [Section 1.5.5](#)).

pct_area_change_limit

The percentage of area changed to be used for each simplification iteration, as explained in the Usage Notes.

Usage Notes

This function reduces the number of vertices in a geometry by internally applying the [SDO_UTIL.SIMPLIFY](#) function (documented in [Chapter 32](#)) with an appropriate threshold value.

Reducing the number of vertices may result in a change in the area of the geometry. The `pct_area_change_limit` parameter specifies how much area change can be tolerated while simplifying the geometry. It is usually a number from 1 to 100. The default value is 2; that is, the area of the geometry can either increase or decrease by at most two percent compared to the original geometry as a result of the geometry simplification.

Examples

The following example simplifies the geometries in the GEOMETRY column of the POLY_4PT_TEMP table.

```
SELECT sdo_sam.simplify_geometry(a.geometry, 0.00000005)
   FROM poly_4pt_temp a, user_sdo_geom_metadata b
   WHERE b.table_name='POLY_4PT_TEMP' ;

SDO_SAM.SIMPLIFY_GEOMETRY(A.GEOMETRY,0.00000005)(ORIG_AREA, CUR_AREA, ORIG_LEN,
-----
SDO_SMPL_GEOMETRY(28108.5905, 28108.5905, 758.440118, 758.440118, SDO_GEOMETRY(2
003, 8307, NULL, SDO_ELEM_INFO_ARRAY(1, 1003, 1), SDO_ORDINATE_ARRAY(-122.4215,
37.7862, -122.422, 37.7869, -122.421, 37.789, -122.42, 37.7866, -122.4215, 37.78
62)))

SDO_SMPL_GEOMETRY(4105.33806, 4105.33806, 394.723053, 394.723053, SDO_GEOMETRY(2
003, 8307, NULL, SDO_ELEM_INFO_ARRAY(1, 1003, 1), SDO_ORDINATE_ARRAY(-122.4019,
37.8052, -122.4027, 37.8055, -122.4031, 37.806, -122.4012, 37.8052, -122.4019, 3
7.8052)))
.
.
.
50 rows selected.
```

SDO_SAM.SIMPLIFY_LAYER

Format

```
SDO_SAM.SIMPLIFY_LAYER(
    theme_tablename    IN VARCHAR2,
    theme_colname      IN VARCHAR2,
    smpl_geom_colname  IN VARCHAR2,
    commit_interval    IN NUMBER DEFAULT 10,
    pct_area_change_limit IN NUMBER DEFAULT 2);
```

Description

Simplifies a geometry layer.

Parameters

theme_tablename

Name of the table containing the geometry layer to be simplified.

theme_colname

Column in `theme_tablename` of type `SDO_GEOMETRY` containing the geometries to be simplified.

smpl_geom_colname

Column in `theme_tablename` of type `SDO_GEOMETRY` into which the simplified geometries are to be placed by this procedure.

commit_interval

Number of geometries to simplify before Spatial performs an internal commit operation. If `commit_interval` is not specified, a commit is performed after every 10 simplification operations.

pct_area_change_limit

The percentage of area changed to be used for each simplification iteration, as explained in the Usage Notes for the [SDO_SAM.SIMPLIFY_GEOMETRY](#) function.

Usage Notes

This procedure simplifies all geometries in a layer. It is equivalent to calling the [SDO_SAM.SIMPLIFY_GEOMETRY](#) function for each geometry in the layer, except that each simplified geometry is put in a separate column in the table instead of being returned to the caller. See also the Usage Notes for the [SDO_SAM.SIMPLIFY_GEOMETRY](#) function.

Examples

The following example adds a column named `SMPL_GEOM` to the `POLY_4PT_TEMP` table, then simplifies all geometries in the `GEOMETRY` column of the `POLY_4PT_TEMP` table, placing each simplified geometry in the `SMPL_GEOM` column in the same row with its associated original geometry.

```
ALTER TABLE poly_4pt_temp ADD (smpl_geom mdsys.sdo_geometry);
```

Table altered.

```
EXECUTE sdo_sam.simplify_layer('POLY_4PT_TEMP', 'GEOMETRY', 'SMPL_GEOM');
```

PL/SQL procedure successfully completed.

SDO_SAM.SPATIAL_CLUSTERS

Format

```
SDO_SAM.SPATIAL_CLUSTERS(
    tablename    IN VARCHAR2,
    colname      IN VARCHAR2,
    max_clusters IN NUMBER,
    allow_outliers IN VARCHAR2 DEFAULT 'TRUE',
    tablepartition IN VARCHAR2 DEFAULT NULL
) RETURN SDO_REGIONSET;
```

Description

Computes clusters using the existing R-tree index, and returns a set of SDO_REGION objects where the geometry column specifies the boundary of each cluster and the `geometry_key` value is set to null.

Parameters

tablename

Name of the data mining table.

colname

Name of the column in `tablename` that holds the location coordinates.

max_clusters

Maximum number of clusters to obtain.

allow_outliers

TRUE (the default) causes outlying values (isolated instances) to be included in the spatial clusters; FALSE causes outlying values not to be included in the spatial clusters. (TRUE accommodates all data and may result in larger clusters; FALSE may exclude some data and may result in smaller clusters.)

tablepartition

Name of the partition in `tablename`.

Usage Notes

The clusters are computed using the spatial R-tree index on `tablename`.

Examples

The following example clusters the locations in cities into at most three clusters, and includes outlying values in the clusters.

```
SELECT * FROM
    TABLE(sdo_sam.spatial_clusters('PROJ_CITIES', 'LOCATION', 3, 'TRUE'));
```

SDO_SAM.TILED_AGGREGATES

Format

```
SDO_SAM.TILED_AGGREGATES(  
    theme_name      IN VARCHAR2,  
    theme_colname   IN VARCHAR2,  
    aggr_type_string IN VARCHAR2,  
    aggr_col_string IN VARCHAR2,  
    tiling_level    IN NUMBER DEFAULT NULL,  
    tiling_domain   IN SDO_DIM_ARRAY DEFAULT NULL,  
    zero_agg_tiles  IN NUMBER DEFAULT 0,  
    xdivs           IN NUMBER DEFAULT NULL,  
    ydivs           IN NUMBER DEFAULT NULL  
) RETURN SDO_REGAGGRSET;
```

Description

Tiles aggregates for a domain. For each tile, computes the intersecting geometries from the theme table; the values in the `aggr_col_string` column are weighted proportionally to the area of the intersection, and aggregated according to `aggr_col_string`.

Parameters

theme_name

Table containing theme information (for example, demographic information).

theme_colname

Name of the column in the `theme_name` table that contains geometry objects.

aggr_type_string

Any Oracle SQL aggregate function that accepts one or more numeric values and computes a numeric value, such as `SUM`, `MIN`, `MAX`, or `AVG`.

aggr_col_string

Name of a column in the `theme_name` table on which to compute aggregate values. An example might be a `POPULATION` column.

tiling_level

Level to be used to create tiles. If you specify this parameter, the extent of each dimension is divided into $2^{\text{tiling_level}}$ parts, resulting in at most $4^{\text{tiling_level}}$ tiles. (Specify either this parameter or the combination of the `xdivs` and `ydivs` parameters.)

tiling_domain

Domain for the tiling level. The parameter is not required, and if you do not specify it, the extent associated with the `theme_name` table is used.

zero_agg_tiles

Specify 0 to exclude tiles that have a value of 0 for the computed aggregate, or specify 1 to return all tiles. The default value is 0, which ensures that only tiles with a nonzero aggregate value are returned.

xdivs

The number of times that the extent in the first dimension is divided, such that the total number of parts is $xdivs + 1$. For example, if you specify 10 for `xdivs`, the extent of the first dimension is divided into 11 parts.

ydivs

The number of times that the extent in the second dimension is divided, such that the total number of parts is $ydivs + 1$. For example, if you specify 10 for `ydivs`, the extent of the second dimension is divided into 11 parts.

Usage Notes

This function is similar to [SDO_SAM.AGGREGATES_FOR_LAYER](#), but the results are dynamically generated using tiling information. Given a `theme_name` table, the tiling domain is determined. Based on the `tiling_level` value or the `xdivs` and `ydivs` values, the necessary tiles are generated. For each tile geometry, thematic aggregates are computed as described in the Usage Notes for [SDO_SAM.AGGREGATES_FOR_LAYER](#).

You must specify either the `tiling_level` parameter or both the `xdivs` and `ydivs` parameters. If you specify all three of these parameters, the `tiling_level` parameter is ignored and the `xdivs` and `ydivs` parameters are used.

If you specify the `xdivs` and `ydivs` parameters, the total number of grids (tiles) returned is $(xdivs+1) * (ydivs+1)$.

This function returns an object of type `SDO_REGAGGRSET`. The `SDO_REGAGGRSET` object type is defined as:

TABLE OF `SDO_REGAGGR`

The `SDO_REGAGGR` object type is defined as:

Name	Null?	Type
REGION_ID		VARCHAR2 (24)
GEOMETRY		MDSYS.SDO_GEOMETRY
AGGREGATE_VALUE		NUMBER

Examples

The following example computes the sum of the population rows of `POLY_4PT_TEMP` table intersecting with each tile. The extent of the `POLY_4PT_TEMP` table stored in the `USER_SDO_GEOM_METADATA` view is used as the domain, and a tiling level of 2 is used (that is, the domain is divided into 16 tiles).

```
SELECT a.geometry, a.aggregate_value
  from TABLE(sdo_sam.tiled_aggregates('POLY_4PT_TEMP',
                                     'GEOMETRY', 'SUM', 'POPULATION', 2)) a;

GEOMETRY(SDO_GTYPE, SDO_SRID, SDO_POINT(X, Y, Z), SDO_ELEM_INFO, SDO_ORDINATES)
-----
AGGREGATE_VALUE
-----
SDO_GEOMETRY(2003, 8307, NULL, SDO_ELEM_INFO_ARRAY(1, 1003, 3), SDO_ORDINATE_ARR
AY(-180, -90, -90, -45))
```

```
.007150754

SDO_GEOMETRY(2003, 8307, NULL, SDO_ELEM_INFO_ARRAY(1, 1003, 3), SDO_ORDINATE_ARRAY(-180, -45, -90, 0))
.034831005

SDO_GEOMETRY(2003, 8307, NULL, SDO_ELEM_INFO_ARRAY(1, 1003, 3), SDO_ORDINATE_ARRAY(-180, 0, -90, 45))
7.73307783

SDO_GEOMETRY(2003, 8307, NULL, SDO_ELEM_INFO_ARRAY(1, 1003, 3), SDO_ORDINATE_ARRAY(-90, -90, 0, -45))
.019498368

SDO_GEOMETRY(2003, 8307, NULL, SDO_ELEM_INFO_ARRAY(1, 1003, 3), SDO_ORDINATE_ARRAY(-90, -45, 0, 0))
.939061456

SDO_GEOMETRY(2003, 8307, NULL, SDO_ELEM_INFO_ARRAY(1, 1003, 3), SDO_ORDINATE_ARRAY(-90, 0, 0, 45))
1.26691592

SDO_GEOMETRY(2003, 8307, NULL, SDO_ELEM_INFO_ARRAY(1, 1003, 3), SDO_ORDINATE_ARRAY(0, 0, 90, 45))
40

7 rows selected.
```

SDO_SAM.TILED_BINS

Format

```
SDO_SAM.TILED_BINS(
    l1      IN NUMBER,
    u1      IN NUMBER,
    l2      IN NUMBER,
    u2      IN NUMBER,
    tiling_level IN NUMBER DEFAULT NULL,
    srid     IN NUMBER DEFAULT NULL,
    xdivs    IN NUMBER DEFAULT NULL,
    ydivs    IN NUMBER DEFAULT NULL
) RETURN SDO_REGIONSET;
```

Description

Tiles a two-dimensional space and returns geometries corresponding to those tiles.

Parameters

l1

Lower bound of the extent in the first dimension.

u1

Upper bound of the extent in the first dimension.

l2

Lower bound of the extent in the second dimension.

u2

Upper bound of the extent in the second dimension.

tiling_level

Level to be used to tile the specified extent. If you specify this parameter, the extent of each dimension is divided into $2^{\text{tiling_level}}$ parts, resulting in at most $4^{\text{tiling_level}}$ tiles. (Specify either this parameter or the combination of the `xdivs` and `ydivs` parameters.)

srid

SRID value to be included for the coordinate system in the returned tile geometries.

xdivs

The number of times that the extent in the first dimension is divided, such that the total number of parts is `xdivs + 1`. For example, if you specify 10 for `xdivs`, the extent of the first dimension is divided into 11 parts.

ydivs

The number of times that the extent in the second dimension is divided, such that the total number of parts is `ydivs + 1`. For example, if you specify 10 for `ydivs`, the extent of the second dimension is divided into 11 parts.

Usage Notes

You must specify either the `tiling_level` parameter or both the `xdivs` and `ydivs` parameters. If you specify all three of these parameters, the `tiling_level` parameter is ignored and the `xdivs` and `ydivs` parameters are used.

If you specify the `xdivs` and `ydivs` parameters, the total number of grids (tiles) returned is $(xdivs+1) * (ydivs+1)$.

This function returns an object of type `SDO_REGIONSET`. The `SDO_REGIONSET` object type is defined as:

TABLE OF `SDO_REGION`

The `SDO_REGION` object type is defined as:

Name	Null?	Type
ID		NUMBER
GEOMETRY		MDSYS.SDO_GEOMETRY

Examples

The following example tiles the entire Earth's surface at the first tiling level, using the standard longitude and latitude coordinate system (SRID 8307). The resulting `SDO_REGIONSET` object contains four `SDO_REGION` objects, one for each tile.

```
SELECT * FROM TABLE(sdo_sam.tiled_bins(-180, 180, -90, 90, 1, 8307))
ORDER BY id;

          ID
-----
GEOMETRY(SDO_GTYPE, SDO_SRID, SDO_POINT(X, Y, Z), SDO_ELEM_INFO, SDO_ORDINATES)
-----
          0
SDO_GEOMETRY(2003, 8307, NULL, SDO_ELEM_INFO_ARRAY(1, 1003, 3), SDO_ORDINATE_ARR
AY(-180, -90, 0, 0))

          1
SDO_GEOMETRY(2003, 8307, NULL, SDO_ELEM_INFO_ARRAY(1, 1003, 3), SDO_ORDINATE_ARR
AY(-180, 0, 0, 90))

          2
SDO_GEOMETRY(2003, 8307, NULL, SDO_ELEM_INFO_ARRAY(1, 1003, 3), SDO_ORDINATE_ARR
AY(0, -90, 180, 0))

          3
SDO_GEOMETRY(2003, 8307, NULL, SDO_ELEM_INFO_ARRAY(1, 1003, 3), SDO_ORDINATE_ARR
AY(0, 0, 180, 90))

4 rows selected.
```

SDO_TIN_PKG Package (TINs)

This chapter contains descriptions of the triangulated irregular network (TIN) subprograms shown in [Table 30–1](#).

Table 30–1 TIN Subprograms

Subprogram	Description
SDO_TIN_PKG.CLIP_TIN	Performs a clip operation on a TIN.
SDO_TIN_PKG.CREATE_TIN	Creates a TIN using the points specified in the <code>inptable</code> parameter.
SDO_TIN_PKG.DROP_DEPENDENCIES	Drops the dependencies between a TIN block table and a specified base table and column.
SDO_TIN_PKG.INIT	Initializes a TIN.
SDO_TIN_PKG.TO_GEOMETRY	Returns a geometry object representing all or part of a TIN.

To use the subprograms in this package, you must understand the main concepts related to three-dimensional geometries, including the use of triangulated irregular networks (TINs) to model surfaces. [Section 1.11](#) describes support for three-dimensional geometries, [Section 1.11.1](#) describes the use of TINs to model surfaces, and [Section 2.5](#) describes data types related to TINs.

SDO_TIN_PKG.CLIP_TIN

Format

```
SDO_TIN_PKG.CLIP_TIN(  
    inp          IN SDO_TIN,  
    qry          IN SDO_GEOMETRY,  
    qry_min_res  IN NUMBER,  
    qry_max_res  IN NUMBER,  
    blkid        IN NUMBER DEFAULT NULL  
    ) RETURN SDO_TIN_BLK_TYPE;
```

Description

Performs a clip operation on a TIN.

Parameters

inp

TIN on which to perform the clip operation.

qry

Window from which to select objects to be returned; typically a polygon for two-dimensional geometries or a frustum for three-dimensional geometries.

qry_min_res

Minimum resolution value. Objects in `qry` with resolutions equal to or greater than `qry_min_res` and less than or equal to `qry_max_res` are returned by the clip operation.

qry_max_res

Maximum resolution value. Objects in `qry` with resolutions equal to or greater than `qry_min_res` and less than or equal to `qry_max_res` are returned by the clip operation.

blkid

Block ID number of the block to which to restrict the objects returned by the clip operation. If this parameter is null, all objects that satisfy the other parameters are returned.

Usage Notes

This function returns triangles from a TIN that are within a specified query window and that satisfy any other requirements specified by the parameters. A common use of this function is to perform queries on TINs. You can maximize the performance of a TIN query by minimizing the number of objects that the function needs to consider for the operation.

The `SDO_TIN` and `SDO_TIN_BLK_TYPE` data types are described in [Section 2.5](#).

[Section 1.11.1](#) describes how to use TINs to model surfaces.

Examples

The following example performs a clip operation on a TIN. It is taken from the `sdo_tin.sql` example program, which is under `$ORACLE_HOME/md/demo/examples/TIN/plsql/` if you installed the files from the Oracle Database Examples media (see *Oracle Database Examples Installation Guide*).

```
. . .
declare
  inp sdo_tin;
begin
  select tin INTO inp  from base where rownum=1;
  insert into restst
  select * from
    table(sdo_tin_pkg.clip_tin
      (
        inp, -- Input TIN object
        sdo_geometry(2003, null, null,
          mdsys.sdo_elem_info_array(1, 1003, 3),
          mdsys.sdo_ordinate_array(-74.1, -73.9, 39.99999,40.00001)), -- Query
        null, null));
end;
. . .
```

SDO_TIN_PKG.CREATE_TIN

Format

```
SDO_TIN_PKG.CREATE_TIN(  
    inp          IN SDO_TIN,  
    inptable     IN VARCHAR2,  
    clstPcdataTbl IN VARCHAR2 DEFAULT NULL);
```

Description

Creates a TIN using the points specified in the `inptable` parameter.

Parameters

inp

SDO_TIN object to be used. This object must have been created by the [SDO_TIN_PKG.INIT](#) function

inptable

Name of the table or view containing the input TIN data. This table or view should have the following columns:

- RID (VARCHAR2(24)): Unique ID for each point
- VAL_D1 (NUMBER): Ordinate in dimension 1
- VAL_D2 (NUMBER): Ordinate in dimension 2
- ...
- VAL_Dn (NUMBER): Ordinate in dimension *n*, where *n* is the highest-numbered dimension. *n* should match the `tin_tot_dimensions` parameter value in the call to the [SDO_TIN_PKG.INIT](#) function when the TIN was initialized.

clstPcdataTbl

Name of the table for storing the resulting point data. If you do not specify a value, this table is not created. For more information about the table, see the Usage Notes.

Usage Notes

The first few dimensions of the TIN are indexed and can later be searched using the [SDO_TIN_PKG.CLIP_TIN](#) function. The exact number of dimensions to index is determined by the dimensionality of the TIN extent in the initialized TIN object, specifically: `inp.tin_extent.sdo_gtype/1000`

If you specify a view name in the `inptable` parameter, the query `SELECT ROWID FROM <view-name>` must not return any errors.

If you specify a table name in the `clstPcdataTbl` parameter, the table must exist and have the following columns:

- PTN_ID (NUMBER)
- POINT_ID (NUMBER)
- RID (VARCHAR2(24)): Unique ID for each point
- VAL_D1 (NUMBER): Ordinate in dimension 1

- VAL_D2 (NUMBER): Ordinate in dimension 2
- ...
- VAL_Dn (NUMBER): Ordinate in dimension *n*, where *n* is the highest-numbered dimension. *n* should match the `tin_tot_dimensions` parameter value in the call to the [SDO_TIN_PKG.INIT](#) function when the TIN was initialized.

If a value is specified for the `clstPcdataTbl` parameter, this function populates the table by assigning appropriate values for `PTN_ID` and `POINT_ID` and by copying the values from the `inptable` table or view for other attributes. This table can be created as an index organized table. It can be used in applications for searching using SQL queries on dimensions other than those reflected in the index dimensionality. (For an explanation of index dimensionality and total dimensionality, see the explanation of the `tin_tot_dimensions` parameter of the [SDO_TIN_PKG.INIT](#) function.)

The `SDO_TIN` data type is described in [Section 2.5](#).

[Section 1.11.1](#) describes how to use TINs to model surfaces.

Examples

The following example creates a TIN. It is taken from the `sdo_tin.sql` example program, which is under `$ORACLE_HOME/md/demo/examples/TIN/plsql/` if you installed the files from the Oracle Database Examples media (see *Oracle Database Examples Installation Guide*).

```

. . .
-- Create the blocks for the TIN.
sdo_tin_pkg.create_tin(
  tin,          -- Initialized TIN object
  'INPTAB',    -- Name of input table to ingest into the pointcloud
  'RES'        -- Name of output table that stores the points (with ptn_id,pt_id)
);
/
. . .

```

SDO_TIN_PKG.DROP_DEPENDENCIES

Format

```
SDO_TIN_PKG.DROP_DEPENDENCIES(  
    basetable IN VARCHAR2,  
    col       IN VARCHAR2);
```

Description

Drops the dependencies between a TIN block table and a specified base table and column.

Parameters

basetable

Name of a base table that was specified (in the `basetable` parameter of the [SDO_TIN_PKG.INIT](#) function) when the TIN was initialized.

col

Name of a column in base table that was specified in the `basecol` parameter of the [SDO_TIN_PKG.INIT](#) function.

Usage Notes

This procedure truncates the TIN block table and removes the association between the block table and the base table and column combination.

After you execute this procedure, you can drop the TIN block table or associate the table with another base table and column combination. For more information, see the Usage Notes for the [SDO_TIN_PKG.INIT](#) function.

Examples

The following example drops the dependencies between a TIN block table and a base table and column named `BASE` and `TIN`, respectively.

```
. . .  
declare  
begin  
    mdsys.sdo_tin_pkg.drop_dependencies('BASE', 'TIN');  
end;  
/
```

SDO_TIN_PKG.INIT

Format

```
SDO_TIN_PKG.INIT(
    basetable      IN VARCHAR2,
    basecol        IN VARCHAR2,
    blktable       IN VARCHAR2,
    ptn_params     IN VARCHAR2,
    tin_extent     IN SDO_GEOMETRY,
    tin_tol        IN NUMBER DEFAULT 0.0000000000000005,
    tin_tot_dimensions IN NUMBER DEFAULT 2,
    tin_domain     IN SDO_ORGSCL_TYPE DEFAULT NULL,
    tin_break_lines IN SDO_GEOMETRY DEFAULT NULL,
    tin_stop_lines IN SDO_GEOMETRY DEFAULT NULL,
    tin_void_rgns  IN SDO_GEOMETRY DEFAULT NULL,
    tin_val_attr_tables IN SDO_STRING_ARRAY DEFAULT NULL,
    tin_other_attrs IN XMLTYPE DEFAULT NULL,
) RETURN SDO_TIN;
```

Description

Initializes a TIN by creating an SDO_TIN object.

Parameters

basetable

Name of the base table containing a column of type SDO_TIN.

basecol

Name of the column of type SDO_TIN in the base table.

blktable

Name of the TIN block table, which is used for storing the blocks of the TIN. This table must exist, and must have been created by a statement in the following form: `CREATE TABLE <table-name> AS select * from mdsys.sdo_tin_blk_table;`

Each TIN block table can only be associated with only one `basetable` and `basecol` combination.

ptn_params

Parameters for partitioning the TIN, specified as a quoted string with keywords delimited by commas. For example: `'blk_capacity=1000,work_tablespace=my_work_ts'`. If this parameter is null, the TIN is not partitioned. The following keywords are permitted:

- `blk_capacity=n`, where *n* is the maximum number of rows in each partition. The default value is 5000. If specified, must be a number greater than or equal to 50.

- `work_tablespace=x`, where *x* is the name of the tablespace in which to create temporary tables during the partitioning operations.

tin_extent

SDO_GEOMETRY object representing the spatial extent of the TIN (the minimum bounding object enclosing all objects in the TIN. This parameter must not be null.

For geodetic data, this geometry must have two dimensions; otherwise, it can have up to four dimensions. The dimensionality of this geometry is used as the minimum value permitted for the `tin_tot_dimensions` parameter, as explained in the description of that parameter.

tin_tol

Tolerance value for objects in the TIN. (For information about spatial tolerance, see Section 1.5.5.) If this parameter is null, the default value is 0.00000000000005.

tin_tot_dimensions

A number specifying the *total dimensionality* of the TIN object. For each point in the TIN blocks, `tin_tot_dimensions` ordinates (values) are stored.

The total dimensionality must be greater than or equal to the index dimensionality, which is the number of dimensions in the `tin_extent` geometry. Specifying total dimensionality greater than index dimensionality enables necessary nonspatial attributes to be retrieved in the same fetch operation with spatial data. The maximum total dimensionality value is 8. The default value for this parameter is 2.

tin_domain

(Not currently used.)

tin_break_lines

(Not currently used.)

tin_stop_lines

(Not currently used.)

tin_void_rgns

(Not currently used.)

tin_val_attr_tables

SDO_STRING_ARRAY object specifying the names of any value attribute tables for the TIN. If this parameter is null, the TIN has no associated value attribute tables. Type SDO_STRING_ARRAY is defined as VARRAY(1048576) OF VARCHAR2(32).

tin_other_attrs

XMLTYPE object specifying any other attributes of the TIN. If this parameter is null, the TIN has no other attributes.

Usage Notes

After you use this function to create an SDO_TIN object, you can create a TIN by specifying this object as input to the [SDO_TIN_PKG.CREATE_TIN](#) procedure.

The SDO_TIN data type is described in [Section 2.5](#).

[Section 1.11.1](#) describes how to use TINs to model surfaces.

Examples

The following example initializes a TIN by creating an SDO_TIN object. It is taken from the `sdo_tin.sql` example program, which is under `$ORACLE_`

HOME/md/demo/examples/TIN/plsql/ if you installed the files from the Oracle Database Examples media (see *Oracle Database Examples Installation Guide*).

```
declare
  tin sdo_tin;
begin
  -- Initialize the TIN object.
  tin := sdo_tin_pkg.init(
    'BASE', -- Table that has the SDO_TIN column defined
    'TIN',  -- Column name of the SDO_TIN object
    'BLKTAB', -- Table to store blocks of the TIN
    'blk_capacity=1000', -- max # of points per block
    mdsys.sdo_geometry(2003, null, null,
      mdsys.sdo_elem_info_array(1,1003,3),
      mdsys.sdo_ordinate_array(-180, -90, 180, 90)), -- Extent
    0.0000000005, -- Tolerance for TIN
    3, -- Total number of dimensions
    null);
  . . .
```

SDO_TIN_PKG.TO_GEOMETRY

Format

```
SDO_TIN_PKG.TO_GEOMETRY(  
    pts      IN BLOB,  
    trs      IN BLOB,  
    num_pts  IN NUMBER,  
    num_trs  IN NUMBER,  
    tin_tot_dim IN NUMBER,  
    srid     IN NUMBER DEFAULT NULL,  
    blk_domain IN SDO_ORGSCL_TYPE DEFAULT NULL  
) RETURN SDO_GEOMETRY;
```

Description

Returns a geometry object representing all or part of a TIN.

Parameters

pts

BLOB containing points.

trs

BLOB containing triangles.

num_pts

Maximum number of points to be included in the resulting geometry.

num_trs

Maximum number of triangles to be included in the resulting geometry.

tin_tot_dim

Number of spatial dimensions defined for the data.

srid

Spatial reference (coordinate system) ID associated with the data. If this parameter is null, no SRID value is associated with the data.

blk_domain

(Not currently used.)

Usage Notes

This function returns a single collection `SDO_GEOMETRY` object that represents all point geometries in the `pts` parameter and all triangle geometries in the `trs` parameter. For example, the points and triangles could reflect the result of a clip operation or the contents of an entire block.

[Section 1.11.1](#) describes how to use TINs to model surfaces.

Examples

The following example returns a multipoint collection geometry object representing a TIN. It is taken from the `sdo_tin.sql` example program, which is under `$ORACLE_HOME/md/demo/examples/TIN/plsql/` if you installed the files from the Oracle Database Examples media (see *Oracle Database Examples Installation Guide*).

```
. . .
-- Return points in blk_id of the TIN as a multipoint collection.
select sdo_tin_pkg.to_geometry(
        a.points,    -- point LOB
        a.triangles, -- point LOB
        a.num_points, -- # of points in the LOB
        a.num_triangles, -- # of points in the LOB
        2, -- index dimensionality (gtype dim in extent in INIT)
        3, -- total dimensionality
        null -- SRID
    ) from blktab a where blk_id=0;
. . .
```

SDO_TUNE Package (Tuning)

This chapter contains descriptions of the tuning subprograms shown in [Table 31-1](#).

Table 31-1 *Tuning Subprograms*

Subprogram	Description
SDO_TUNE.AVERAGE_MBR	Calculates the average minimum bounding rectangle for geometries in a layer.
SDO_TUNE.ESTIMATE_RTREE_INDEX_SIZE	Estimates the maximum number of megabytes needed for an R-tree spatial index table.
SDO_TUNE.EXTENT_OF	Returns the minimum bounding rectangle of the data in a layer.
SDO_TUNE.MIX_INFO	Calculates geometry type information for a spatial layer, such as the percentage of each geometry type.
SDO_TUNE.QUALITY_DEGRADATION	Returns the quality degradation for an index or the average quality degradation for all index tables for an index, or returns the quality degradation for a specified index table. (Deprecated)

SDO_TUNE.AVERAGE_MBR

Format

```
SDO_TUNE.AVERAGE_MBR(  
    table_name  IN VARCHAR2,  
    column_name IN VARCHAR2,  
    width       OUT NUMBER,  
    height      OUT NUMBER);
```

Description

Calculates the average minimum bounding rectangle (MBR) for geometries in a layer.

Parameters

table_name

Spatial geometry table.

column_name

Geometry column for which the average minimum bounding rectangle is to be computed.

width

Width of the average minimum bounding rectangle.

height

Height of the average minimum bounding rectangle.

Usage Notes

This procedure computes and stores the width and height of the average minimum bounding rectangle for all geometries in a spatial geometry table. It calculates the average MBR by keeping track of the maximum and minimum X and Y values for all geometries in a spatial geometry table.

Examples

The following example calculates the minimum bounding rectangle for the SHAPE column of the COLA_MARKETS table.

```
DECLARE  
    table_name VARCHAR2(32) := 'COLA_MARKETS';  
    column_name VARCHAR2(32) := 'SHAPE';  
    width NUMBER;  
    height NUMBER;  
BEGIN  
    SDO_TUNE.AVERAGE_MBR(  
        table_name,  
        column_name,  
        width,  
        height);  
    DBMS_OUTPUT.PUT_LINE('Width = ' || width);  
    DBMS_OUTPUT.PUT_LINE('Height = ' || height);  
END;
```

/
Width = 3.5
Height = 4.5

Related Topics

[SDO_AGGR_MBR](#) spatial aggregate function (in [Chapter 20](#))

SDO_TUNE.ESTIMATE_RTREE_INDEX_SIZE

Format

```
SDO_TUNE.ESTIMATE_RTREE_INDEX_SIZE(  
    schemaname IN VARCHAR2,  
    tabname    IN VARCHAR2,  
    colname    IN VARCHAR2,  
    partname   IN VARCHAR2 DEFAULT NULL  
    ) RETURN NUMBER;
```

or

```
SDO_TUNE.ESTIMATE_RTREE_INDEX_SIZE(  
    number_of_geoms IN INTEGER,  
    db_block_size   IN INTEGER,  
    sdo_rtr_pctfree IN INTEGER DEFAULT 10,  
    num_dimensions  IN INTEGER DEFAULT 2,  
    is_geodetic     IN INTEGER DEFAULT 0  
    ) RETURN NUMBER;
```

Description

Estimates the maximum number of megabytes needed for an R-tree spatial index table.

Parameters

schemaname

Schema that owns the spatial geometry table.

tabname

Spatial geometry table name.

colname

Geometry column name.

partname

Name of a partition containing geometries from `colname`. If you specify this parameter, the value returned by the function is the estimated size for an R-tree index table on geometries in that partition. If you do not specify this parameter, the value is the estimated size for an R-tree index table on all geometries in `colname`.

number_of_geoms

Approximate number of geometries in the spatial geometry table.

db_block_size

Database block size (in bytes).

sdo_rtr_pctfree

Minimum percentage of slots in each index tree node to be left empty when the index is created. Slots that are left empty can be filled later when new data is inserted into the table. The value can range from 0 to 50. The default value (10) is best for most applications; however, a value of 0 is recommended if no updates will be performed to the geometry column.

num_dimensions

Number of dimensions to be indexed. The default value is 2. If you plan to specify the `sdo_indx_dims` parameter in the [CREATE INDEX](#) statement, the `num_dimensions` value should match the `sdo_indx_dims` value.

is_geodetic

A value indicating whether or not the spatial index will be a geodetic index: 1 for a geodetic index, or 0 (the default) for a non-geodetic index.

Usage Notes

The function returns the estimated maximum number of megabytes needed for the spatial index table (described in [Section 2.9.2](#)) for an R-tree spatial index to be created. The value returned is the maximum number of megabytes needed after index creation. During index creation, approximately three times this value of megabytes will be needed in the tablespace, to ensure that there is enough space for temporary tables while the index is being created.

This function has two formats:

- Use the format with character string parameters (`schemaname`, `tabname`, `colname`, and optionally `partname`) in most cases when the spatial geometry table already exists, you do not plan to add substantially more geometries to it before creating the index, and you plan to use the default R-tree indexing parameters.
- Use the format with integer parameters (`number_of_geoms`, `db_block_size`, `sdo_rtr_pctfree`, `num_dimensions`, `is_geodetic`) in any of the following cases: the spatial geometry table does not exist; the spatial geometry table exists but you plan to add substantially more geometries to it before creating the index; or the `num_dimensions` value is not 2 for non-geodetic data or 3 for geodetic data, and a nondefault value will be specified using the `sdo_indx_dims` parameter in the [CREATE INDEX](#) statement.

Examples

The following example estimates the maximum number of megabytes needed for a spatial index table for an index given the following information: `number_of_geoms = 1000000` (one million), `db_block_size = 2048`, `sdo_rtr_pctfree = 10`, `num_dimensions = 2`, `is_geodetic = 0`.

```
SELECT SDO_TUNE.ESTIMATE_RTREE_INDEX_SIZE(1000000, 2048, 10, 2, 0) FROM DUAL;
```

```
SDO_TUNE.ESTIMATE_RTREE_INDEX_SIZE(1000000,2048,10,2,0)
```

```
-----  
82
```

The following example estimates the maximum number of megabytes needed for a spatial index table for an index on the `SHAPE` column in the `COLA_MARKETS` table in the `SCOTT` schema. The estimate is based on the geometries that are currently in the table.

```
SELECT SDO_TUNE.ESTIMATE_RTREE_INDEX_SIZE('SCOTT', 'COLA_MARKETS', 'SHAPE') FROM  
DUAL;
```

```
SDO_TUNE.ESTIMATE_RTREE_INDEX_SIZE('SCOTT', 'COLA_MARKETS', 'SHAPE')
```

1

SDO_TUNE.EXTENT_OF

Format

```
SDO_TUNE.EXTENT_OF(
    table_name  IN VARCHAR2,
    column_name IN VARCHAR2
) RETURN SDO_GEOMETRY;
```

Description

Returns the minimum bounding rectangle (MBR) of all geometries in a layer.

Parameters

table_name

Spatial geometry table.

column_name

Geometry column for which the minimum bounding rectangle is to be returned.

Usage Notes

The [SDO_AGGR_MBR](#) function, documented in [Chapter 20](#), also returns the MBR of geometries. The SDO_TUNE.EXTENT_OF function has better performance than the [SDO_AGGR_MBR](#) function if a spatial index is defined on the geometry column; however, the SDO_TUNE.EXTENT_OF function is limited to two-dimensional geometries, whereas the [SDO_AGGR_MBR](#) function is not. In addition, the SDO_TUNE.EXTENT_OF function computes the extent for all geometries in a table; by contrast, the [SDO_AGGR_MBR](#) function can operate on subsets of rows.

If a spatial index is used, this function may return an approximate MBR that encloses the largest extent of data stored in the index, even if data was subsequently deleted.

Examples

The following example calculates the minimum bounding rectangle for the objects in the SHAPE column of the COLA_MARKETS table.

```
SELECT SDO_TUNE.EXTENT_OF('COLA_MARKETS', 'SHAPE')
       FROM DUAL;
```

```
SDO_TUNE.EXTENT_OF('COLA_MARKETS', 'SHAPE')(SDO_GTYPE, SDO_SRID, SDO_POINT(X, Y,
-----
SDO_GEOMETRY(2003, NULL, NULL, SDO_ELEM_INFO_ARRAY(1, 1003, 3), SDO_ORDINATE_
ARRAY(1, 1, 10, 11))
```

Related Topics

[SDO_AGGR_MBR](#) aggregate function (in [Chapter 20](#))

[SDO_TUNE.AVERAGE_MBR](#) procedure

SDO_TUNE.MIX_INFO

Format

```
SDO_TUNE.MIX_INFO(  
    table_name    IN VARCHAR2,  
    column_name   IN VARCHAR2  
    [, total_geom OUT INTEGER,  
    point_geom    OUT INTEGER,  
    curve_geom    OUT INTEGER,  
    poly_geom     OUT INTEGER,  
    complex_geom  OUT INTEGER] );
```

Description

Calculates geometry type information for a spatial layer, such as the percentage of each geometry type.

Parameters

table_name

Spatial geometry table.

column_name

Geometry object column for which the geometry type information is to be calculated.

total_geom

Total number of geometry objects.

point_geom

Number of point geometry objects.

curve_geom

Number of curve string geometry objects.

poly_geom

Number of polygon geometry objects.

complex_geom

Number of complex geometry objects.

Usage Notes

This procedure calculates geometry type information for the table. It calculates the total number of geometries, as well as the number of point, curve string, polygon, and complex geometries.

Examples

The following example displays information about the mix of geometry objects in the SHAPE column of the COLA_MARKETS table.

```
CALL SDO_TUNE.MIX_INFO('COLA_MARKETS', 'SHAPE');
```

Total number of geometries: 4
Point geometries: 0 (0%)
Curvestring geometries: 0 (0%)
Polygon geometries: 4 (100%)
Complex geometries: 0 (0%)

SDO_TUNE.QUALITY_DEGRADATION

Format

```
SDO_TUNE.QUALITY_DEGRADATION(  
    schemaname IN VARCHAR2,  
    indexname   IN VARCHAR2  
    ) RETURN NUMBER;
```

or

```
SDO_TUNE.QUALITY_DEGRADATION(  
    schemaname IN VARCHAR2,  
    indexname   IN VARCHAR2,  
    indextable  IN VARCHAR2  
    ) RETURN NUMBER;
```

Description

Returns the quality degradation for an index or the average quality degradation for all index tables for an index, or returns the quality degradation for a specified index table.

Note: This function is deprecated, and it will not be documented in future releases. You should not use this function. It is not needed because Spatial indexes are self-tuning.

Parameters

schemaname

Name of the schema that contains the index specified in `indexname`.

indexname

Name of the spatial R-tree index.

indextable

Name of an index table associated with the spatial R-tree index specified in `indexname`.

Usage Notes

This function is deprecated and will not be included in future releases of this manual. You should not use this function because Spatial indexes are self-tuning. The rest of the usage notes for this function are from the previous release of this manual.

The **quality degradation** is a number indicating approximately how much longer it will take to execute the I/O operations of the index portion of any given query with the current index, compared to executing the I/O operations of the index portion of the same query when the index was created or most recently rebuilt. For example, if the I/O operations of the index portion of a typical query will probably take twice as much time as when the index was created or rebuilt, the quality degradation is 2. The exact degradation in overall query time is impossible to predict; however, a substantial

quality degradation (2 or 3 or higher) can affect query performance significantly for large databases, such as those with millions of rows.

For local partitioned indexes, you must use the format that includes the `indextable` parameter. That is, you must compute the quality degradation for each partition in which you are interested.

Index names are available through the `xxx_SDO_INDEX_INFO` and `xxx_SDO_INDEX_METADATA` views, which are described in [Section 2.9.1](#).

For more information and guidelines relating to R-tree quality and its possible effect on query performance, see [Section 1.7.2](#).

Examples

The following example returns the quality degradation for the `COLA_SPATIAL_IDX` index. In this example, the quality has not degraded at all, and therefore the degradation is 1; that is, the I/O operations of the index portion of queries will typically take the same time using the current index as using the original or previous index.

```
SELECT SDO_TUNE.QUALITY_DEGRADATION('SCOTT', 'COLA_SPATIAL_IDX') FROM DUAL;

SDO_TUNE.QUALITY_DEGRADATION('SCOTT', 'COLA_SPATIAL_IDX')
-----
1
```

SDO_UTIL Package (Utility)

This chapter contains descriptions of the spatial utility subprograms shown in Table 32-1.

Table 32-1 Spatial Utility Subprograms

Subprogram	Description
SDO_UTIL.AFFINETRANSFORMS	Returns a geometry that reflects an affine transformation of the input geometry.
SDO_UTIL.APPEND	Appends one geometry to another geometry to create a new geometry.
SDO_UTIL.BEARING_TILT_FOR_POINTS	Computes the bearing and tilt from a start point to an end point.
SDO_UTIL.CIRCLE_POLYGON	Returns the polygon geometry that approximates and is covered by a specified circle.
SDO_UTIL.CONCAT_LINES	Concatenates two line or multiline two-dimensional geometries to create a new geometry.
SDO_UTIL.CONVERT_UNIT	Converts values from one angle, area, or distance unit of measure to another.
SDO_UTIL.ELLIPSE_POLYGON	Returns the polygon geometry that approximates and is covered by a specified ellipse.
SDO_UTIL.EXTRACT	Returns the two-dimensional geometry that represents a specified element (and optionally a ring) of the input two-dimensional geometry.
SDO_UTIL.EXTRACT_ALL	Returns all elements and subelements of the input two-dimensional geometry, as an array of one or more geometries.
SDO_UTIL.EXTRACT3D	Returns the three-dimensional geometry that represents a specified subset of the input three-dimensional geometry.
SDO_UTIL.EXTRUDE	Returns the three-dimensional extrusion solid geometry from an input two-dimensional polygon geometry.
SDO_UTIL.FROM_GML311GEOMETRY	Converts a geography markup language (GML 3.1.1) fragment to a Spatial geometry object.
SDO_UTIL.FROM_GMLGEOMETRY	Converts a geography markup language (GML 2.0) fragment to a Spatial geometry object.
SDO_UTIL.FROM_KMLGEOMETRY	Converts a KML (Keyhole Markup Language) document to a Spatial geometry object.

Table 32–1 (Cont.) Spatial Utility Subprograms

Subprogram	Description
SDO_UTIL.FROM_WKBGEOMETRY	Converts a geometry in the well-known binary (WKB) format to a Spatial geometry object.
SDO_UTIL.FROM_WKTGEOMETRY	Converts a geometry in the well-known text (WKT) format to a Spatial geometry object.
SDO_UTIL.GETNUMELEM	Returns the number of elements in the input geometry.
SDO_UTIL.GETNUMVERTICES	Returns the number of vertices in the input geometry.
SDO_UTIL.GETVERTICES	Returns the coordinates of the vertices of the input geometry.
SDO_UTIL.INITIALIZE_INDEXES_FOR_TTS	Initializes all spatial indexes in a tablespace that was transported to another database.
SDO_UTIL.INTERIOR_POINT	Returns a point that is guaranteed to be an interior point (not on the boundary or edge) on the surface of a polygon geometry object.
SDO_UTIL.POINT_AT_BEARING	Returns a point geometry that is at the specified distance and bearing from the start point.
SDO_UTIL.POLYGONTOLINE	Converts all polygon-type elements in a geometry to line-type elements, and sets the SDO_GTYPE value accordingly.
SDO_UTIL.PREPARE_FOR_TTS	Prepares a tablespace to be transported to another database, so that spatial indexes will be preserved during the transport operation.
SDO_UTIL.RECTIFY_GEOMETRY	Fixes certain problems with the input geometry, and returns a valid geometry.
SDO_UTIL.REMOVE_DUPLICATE_VERTICES	Removes duplicate (redundant) vertices from a geometry.
SDO_UTIL.REVERSE_LINestring	Returns a line string geometry with the vertices of the input geometry in reverse order.
SDO_UTIL.SIMPLIFY	Simplifies the input geometry, based on a threshold value, using the Douglas-Peucker algorithm.
SDO_UTIL.TO_GML311GEOMETRY	Converts a Spatial geometry object to a geography markup language (GML 3.1.1) fragment based on the geometry types defined in the Open GIS <code>geometry.xsd</code> schema document.
SDO_UTIL.TO_GMLGEOMETRY	Converts a Spatial geometry object to a geography markup language (GML 2.0) fragment based on the geometry types defined in the Open GIS <code>geometry.xsd</code> schema document.
SDO_UTIL.TO_KMLGEOMETRY	Converts a Spatial geometry object to a KML (Keyhole Markup Language) document.
SDO_UTIL.TO_WKBGEOMETRY	Converts a Spatial geometry object to the well-known binary (WKB) format.
SDO_UTIL.TO_WKTGEOMETRY	Converts a Spatial geometry object to the well-known text (WKT) format.
SDO_UTIL.VALIDATE_WKBGEOMETRY	Validates the input geometry, which is in the standard well-known binary (WKB) format; returns the string <code>TRUE</code> if the geometry is valid or <code>FALSE</code> if the geometry is not valid.

Table 32–1 (Cont.) Spatial Utility Subprograms

Subprogram	Description
<code>SDO_UTIL.VALIDATE_WKTGEOMETRY</code>	Validates the input geometry, which is of type CLOB or VARCHAR2 and in the standard well-known text (WKT) format; returns the string <code>TRUE</code> if the geometry is valid or <code>FALSE</code> if the geometry is not valid.

SDO_UTIL.AFFINETRANSFORMS

Format

```
SDO_UTIL.AFFINETRANSFORMS(  
  geometry IN SDO_GEOMETRY,  
  translation IN VARCHAR2,  
  tx        IN NUMBER,  
  ty        IN NUMBER,  
  tz        IN NUMBER,  
  scaling   IN VARCHAR2,  
  psc1     IN SDO_GEOMETRY  
  sx        IN NUMBER,  
  sy        IN NUMBER,  
  sz        IN NUMBER,  
  rotation  IN VARCHAR2,  
  p1       IN SDO_GEOMETRY,  
  line1    IN SDO_GEOMETRY,  
  angle    IN NUMBER,  
  dir      IN NUMBER,  
  shearing IN VARCHAR2  
  shxy    IN NUMBER,  
  shyx    IN NUMBER,  
  shxz    IN NUMBER,  
  shzx    IN NUMBER,  
  shyz    IN NUMBER,  
  shzy    IN NUMBER,  
  reflection IN VARCHAR2  
  pref    IN SDO_GEOMETRY,  
  lineR   IN SDO_GEOMETRY,  
  dirR    IN NUMBER,  
  planeR  IN VARCHAR2,  
  n       IN SDO_NUMBER_ARRAY,  
  bigD    IN SDO_NUMBER_ARRAY,  
  ) RETURN SDO_GEOMETRY;
```

Description

Returns a geometry that reflects an affine transformation of the input geometry.

Parameters

geometry

Input geometry on which to perform the affine transformation.

translation

A string value of TRUE causes translation to be performed; a string value of FALSE causes translation not to be performed. If this parameter is TRUE, translation is performed about the point at (tx,ty) or (tx,ty,tz).

tx

X-axis value for translation.

ty

Y-axis value for translation.

tz

Z-axis value for translation.

scaling

A string value of TRUE causes scaling to be performed; a string value of FALSE causes scaling not to be performed.

psc1

Point on the input geometry about which to perform the scaling. If `scaling` is TRUE, this geometry should be either a zero point (point geometry with 0,0 or 0,0,0 ordinates for scaling about the origin) or a nonzero point (point geometry with ordinates for scaling about a point other than the origin). If `scaling` is FALSE, `psc1` can be a null value.

sx

X-axis value for scaling (about either the point specified in the `psc1` parameter or the origin).

sy

Y-axis value for scaling (about either the point specified in the `psc1` parameter or the origin).

sz

Z-axis value for scaling (about either the point specified in the `psc1` parameter or the origin).

rotation

A string value of TRUE causes rotation to be performed; a string value of FALSE causes rotation not to be performed.

For two-dimensional geometries, rotation uses the `p1` and `angle` values. For three-dimensional geometries, rotation uses either the `angle` and `dir` values or the `line1` and `angle` values.

p1

Point for two-dimensional geometry rotation about a specified point.

line1

Line for rotation about a specified axis.

angle

Angle rotation parameter (in radians) for rotation about a specified axis or about the X, Y, or Z axis.

dir

Rotation parameter for x(0), y(1), or z(2)-axis roll. If the `rotation` parameter value is `TRUE` but the `dir` parameter is not used, specify a value of -1.

shearing

A string value of `TRUE` causes shearing to be performed; a string value of `FALSE` causes shearing not to be performed.

For two-dimensional geometries, shearing uses the `shxy` and `shyx` parameter values. For three-dimensional geometries, shearing uses the `shxy`, `shyx`, `shxz`, `shzx`, `shyz`, and `shzy` parameter values.

shxy

Value for shearing due to X along the Y direction.

shyx

Value for shearing due to Y along the X direction.

shxz

Value for shearing due to X along the Z direction (three-dimensional geometries only).

shzx

Value for shearing due to Z along the X direction (three-dimensional geometries only).

shyz

Value for shearing due to Y along the Z direction (three-dimensional geometries only).

shzy

Value for shearing due to Z along the Y direction (three-dimensional geometries only).

reflection

A string value of `TRUE` causes reflection to be performed; a string value of `FALSE` causes reflection not to be performed.

For two-dimensional geometries, reflection uses the `lineR` value for reflection about an axis and the `pref` value for the centroid for self-reflection. For three-dimensional geometries, reflection uses the `lineR` value for reflection about an axis; the `dirR` value for reflection about the yz, xz, and xy planes; the `planeR`, `n`, and `bigD` values for reflection about a specified plane; and the `pref` value for the centroid for self-reflection.

pref

Point through which to perform reflection.

lineR

Line along which to perform reflection.

dirR

Number indicating the plane about (through) which to perform reflection: 0 for the yz plane, 1 for the xz plane, or 2 for the xy plane. If the `reflection` parameter value is `TRUE` but the `dirR` parameter is not used, specify a value of -1.

planeR

A string value of TRUE causes reflection about an arbitrary plane to be performed; a string value of FALSE causes reflection about an arbitrary plane not to be performed.

n

Normal vector of the plane.

bigD

Delta value for the plane equation in three-dimensional geometries.

For three-dimensional geometries, bigD = delta and n = (A,B,C) where n is the normal of the plane in three-dimensional space. Thus, the plane equation is:

$$Ax+By+Cz+bigD = 3DDotProd(n, anypointonplane)+bigD = 0$$

Usage Notes

The order of affine transforms matter because these are matrix and vector multiplications.

You should validate the resulting geometry using the [SDO_GEOM.VALIDATE_GEOMETRY_WITH_CONTEXT](#) function.

Examples

The following example performs an affine transformation on a two-dimensional geometry.

```
-- Polygon reflection in 2D about a specified line segment
SELECT SDO_UTIL.AFFINETRANSFORMS (
  geometry => MDSYS.SDO_GEOMETRY(2003, NULL, NULL,
    MDSYS.SDO_ELEM_INFO_ARRAY(1,1003,1),
    MDSYS.SDO_ORDINATE_ARRAY(
      1.5,0,
      2.5,1,
      1.5,2,
      0.5,2,
      0.5,0,
      1.5,0)),
  translation => 'FALSE',
  tx => 0.0,
  ty => 0.0,
  tz => 0.0,
  scaling => 'FALSE',
  psc1 => NULL,
  sx => 0.0,
  sy => 0.0,
  sz => 0.0,
  rotation => 'FALSE',
  p1 => NULL,
  line1 => NULL,
  angle => 0.0,
  dir => 0,
  shearing => 'FALSE',
  shxy => 0.0,
  shyx => 0.0,
  shxz => 0.0,
  shzx => 0.0,
  shyz => 0.0,
  shzy => 0.0,
  reflection => 'TRUE',
```

```

pref => NULL,
lineR => MDSYS.SDO_GEOMETRY(2002,0,NULL,
  MDSYS.SDO_ELEM_INFO_ARRAY(1,2,1),
  MDSYS.SDO_ORDINATE_ARRAY(2.5,0.0,2.5,2.0)),
dirR => -1,
planeR => 'FALSE',
n => NULL,
bigD => NULL
) FROM DUAL;

SDO_UTIL.AFFINETRANSFORMS(GEOMETRY=>MDSYS.SDO_GEOMETRY(2003,NULL,NULL,MDSYS.SDO_
-----
SDO_GEOMETRY(2003, NULL, NULL, SDO_ELEM_INFO_ARRAY(1, 1003, 1), SDO_ORDINATE_ARR
AY(3.5, 0, 2.5, 1, 3.5, 2, 4.5, 2, 4.5, 0, 3.5, 0))

```

The following example performs an affine transformation on a three-dimensional geometry.

```

-- Polygon reflection in 3D about a specified plane (z=1 plane in this example)
SELECT SDO_UTIL.AFFINETRANSFORMS(
  geometry => MDSYS.SDO_GEOMETRY(3003, 0, NULL,
    MDSYS.SDO_ELEM_INFO_ARRAY(1,1003,1),
    MDSYS.SDO_ORDINATE_ARRAY(
      1.5,0,0,
      2.5,1,0,
      1.5,2,0,
      0.5,2,0,
      0.5,0,0,
      1.5,0,0)),
  translation => 'FALSE',
  tx => 0.0,
  ty => 0.0,
  tz => 0.0,
  scaling => 'FALSE',
  psc1 => NULL,
  sx => 0.0,
  sy => 0.0,
  sz => 0.0,
  rotation => 'FALSE',
  p1 => NULL,
  line1 => NULL,
  angle => 0.0,
  dir => 0,
  shearing => 'FALSE',
  shxy => 0.0,
  shyx => 0.0,
  shxz => 0.0,
  shzx => 0.0,
  shyz => 0.0,
  shzy => 0.0,
  reflection => 'TRUE',
  pref => NULL,
  lineR => NULL,
  dirR => -1,
  planeR => 'TRUE',
  n => SDO_NUMBER_ARRAY(0.0, 0.0, 1.0),
  bigD => SDO_NUMBER_ARRAY(-1.0)
) FROM DUAL;

SDO_UTIL.AFFINETRANSFORMS(GEOMETRY=>MDSYS.SDO_GEOMETRY(3003,0,NULL,MDSYS.SDO_ELE
-----

```



```
SDO_GEOMETRY(3003, NULL, NULL, SDO_ELEM_INFO_ARRAY(1, 1003, 1), SDO_ORDINATE_ARRAY(1.5, 0, 2, 2.5, 1, 2, 1.5, 2, 2, .5, 2, 2, .5, 0, 2, 1.5, 0, 2))
```

Related Topics

- [SDO_UTIL.CONVERT_UNIT](#)
- [SDO_UTIL.POINT_AT_BEARING](#)

SDO_UTIL.APPEND

Format

```
SDO_UTIL.APPEND(  
    geometry1 IN SDO_GEOMETRY,  
    geometry2 IN SDO_GEOMETRY  
    ) RETURN SDO_GEOMETRY;
```

Description

Appends one geometry to another geometry to create a new geometry.

Parameters

geometry1

Geometry object to which *geometry2* is to be appended.

geometry2

Geometry object to append to *geometry1*.

Usage Notes

This function should be used only on geometries that do not have any spatial interaction (that is, on disjoint objects). If the input geometries are not disjoint, the resulting geometry might be invalid.

This function does not perform a union operation or any other computational geometry operation. To perform a union operation, use the [SDO_GEOM.SDO_UNION](#) function, which is described in [Chapter 24](#). The APPEND function executes faster than the [SDO_GEOM.SDO_UNION](#) function.

The geometry type (SDO_GTYPE value) of the resulting geometry reflects the types of the input geometries and the append operation. For example, if the input geometries are two-dimensional polygons (SDO_GTYPE = 2003), the resulting geometry is a two-dimensional multipolygon (SDO_GTYPE = 2007).

An exception is raised if *geometry1* and *geometry2* are based on different coordinate systems.

Examples

The following example appends the *cola_a* and *cola_c* geometries. (The example uses the definitions and data from [Section 2.1](#).)

```
SELECT SDO_UTIL.APPEND(c_a.shape, c_c.shape)  
FROM cola_markets c_a, cola_markets c_c  
WHERE c_a.name = 'cola_a' AND c_c.name = 'cola_c';
```

```
SDO_UTIL.APPEND(C_A.SHAPE,C_C.SHAPE)(SDO_GTYPE, SDO_SRID, SDO_POINT(X, Y, Z), SD  
-----  
SDO_GEOMETRY(2007, NULL, NULL, SDO_ELEM_INFO_ARRAY(1, 1003, 3, 5, 1003, 1), SDO_  
ORDINATE_ARRAY(1, 1, 5, 7, 3, 3, 6, 3, 6, 5, 4, 5, 3, 3))
```

Related Topics

- [SDO_GEOM.SDO_UNION](#) (in [Chapter 24](#))

SDO_UTIL.BEARING_TILT_FOR_POINTS

Format

```
SDO_UTIL.BEARING_TILT_FOR_POINTS(  
    start_point IN SDO_GEOMETRY,  
    end_point  IN SDO_GEOMETRY,  
    tol        IN NUMBER,  
    bearing    OUT NUMBER,  
    tilt       OUT NUMBER  
) RETURN SDO_GEOMETRY;
```

Description

Computes the bearing and tilt from a start point to an end point.

Parameters

start_point

Starting point geometry object from which to compute the bearing and tilt. The point geometry must be based on a geodetic coordinate system.

end_point

Ending point geometry object to use in computing the bearing and tilt. The point geometry must be based on the same geodetic coordinate system as `start_point`.

tol

Tolerance value (see [Section 1.5.5](#)).

bearing

Number of radians, measured clockwise from North.

tilt

Number of radians, measured from the normal.

Usage Notes

The input point geometries must be based on the same geodetic coordinate system. If they are based on a non-geodetic coordinate system, the output bearing is a null value.

The tilt is computed as the arctangent of the difference between the height values divided by the distance between the points (with height excluded from the distance calculation). That is: $tilt = \text{atan}(\text{height_difference}/\text{distance})$

To convert radians to decimal degrees or decimal degrees to radians, you can use the [SDO_UTIL.CONVERT_UNIT](#) function. To return a point geometry that is at a specified distance and bearing from a start point, you can use the [SDO_UTIL.POINT_AT_BEARING](#) function.

Examples

The following example computes the bearing and tilt for two longitude/latitude points, where the elevation of the start point is 0 (zero) and the elevation of the end point is 5000 meters. This example displays the bearing and tilt values in radians.

```
DECLARE
  bearing NUMBER;
  tilt    NUMBER;
BEGIN
  SDO_UTIL.BEARING_TILT_FOR_POINTS(
    SDO_GEOMETRY(2001, 8307,
      SDO_POINT_TYPE(-71.5, 43, 0), NULL, NULL), -- start_point
    SDO_GEOMETRY(2001, 8307,
      SDO_POINT_TYPE(-71, 43.5, 5000), NULL, NULL), -- end_point
    0.05, --tolerance
    bearing,
    tilt);
  DBMS_OUTPUT.PUT_LINE('Bearing = ' || bearing);
  DBMS_OUTPUT.PUT_LINE('Tilt = ' || tilt);
END;
/
Bearing = .628239101930666
Tilt = .0725397288678286910476298724869396973718
```

The following example is the same as the preceding one, except that it displays the bearing and tilt in decimal degrees instead of radians.

```
DECLARE
  bearing NUMBER;
  tilt    NUMBER;
BEGIN
  SDO_UTIL.BEARING_TILT_FOR_POINTS(
    SDO_GEOMETRY(2001, 8307,
      SDO_POINT_TYPE(-71.5, 43, 0), NULL, NULL), -- start_point
    SDO_GEOMETRY(2001, 8307,
      SDO_POINT_TYPE(-71, 43.5, 5000), NULL, NULL), -- end_point
    0.05, --tolerance
    bearing,
    tilt);
  DBMS_OUTPUT.PUT_LINE('Bearing in degrees = '
    || bearing * 180 / 3.1415926535897932384626433832795);
  DBMS_OUTPUT.PUT_LINE('Tilt in degrees = '
    || tilt * 180 / 3.1415926535897932384626433832795);
END;
/
Bearing in degrees = 35.99544906571628894295547577999851892359
Tilt in degrees = 4.15622031114988533540349823511872120415
```

Related Topics

- [SDO_UTIL.CONVERT_UNIT](#)
- [SDO_UTIL.POINT_AT_BEARING](#)

SDO_UTIL.CIRCLE_POLYGON

Format

```
SDO_UTIL.CIRCLE_POLYGON(
    center_longitude IN NUMBER,
    center_latitude  IN NUMBER,
    radius           IN NUMBER,
    arc_tolerance    IN NUMBER
) RETURN SDO_GEOMETRY;
```

Description

Returns the polygon geometry that approximates and is covered by a specified circle.

Parameters

center_longitude

Center longitude (in degrees) of the circle to be used to create the returned geometry.

center_latitude

Center latitude (in degrees) of the circle to be used to create the returned geometry.

radius

Length (in meters) of the radius of the circle to be used to create the returned geometry.

arc_tolerance

A numeric value to be used to construct the polygon geometry. The `arc_tolerance` parameter value has the same meaning and usage guidelines as the `arc_tolerance` keyword value in the `params` parameter string for the [SDO_GEOM.SDO_ARC_DENSIFY](#) function. The unit of measurement associated with the geometry is associated with the `arc_tolerance` parameter value. (For more information, see the Usage Notes for the [SDO_GEOM.SDO_ARC_DENSIFY](#) function in [Chapter 24](#).)

Usage Notes

This function is useful for creating a circle-like polygon around a specified center point when a true circle cannot be used (a circle is not valid for geodetic data with Oracle Spatial). The returned geometry has an `SDO_SRID` value of 8307 (for Longitude / Latitude (WGS 84)).

Examples

The following example returns a circle-like polygon around a point near the center of Concord, Massachusetts. A `radius` value of 100 meters and an `arc_tolerance` value of 5 meters are used in computing the polygon vertices.

```
SELECT SDO_UTIL.CIRCLE_POLYGON(-71.34937, 42.46101, 100, 5)
FROM DUAL;
```

```
SDO_UTIL.CIRCLE_POLYGON(-71.34937,42.46101,100,5) (SDO_GTYPE, SDO_SRID, SDO_POINT
-----
SDO_GEOMETRY(2003, 8307, NULL, SDO_ELEM_INFO_ARRAY(1, 1003, 1), SDO_ORDINATE_ARR
```

```
AY(-71.34937, 42.4601107, -71.348653, 42.4602824, -71.348211, 42.4607321, -71.34  
8211, 42.4612879, -71.348653, 42.4617376, -71.34937, 42.4619093, -71.350087, 42.  
4617376, -71.350529, 42.4612879, -71.350529, 42.4607321, -71.350087, 42.4602824,  
-71.34937, 42.4601107))
```

Related Topics

- [SDO_UTIL.ELLIPSE_POLYGON](#)

SDO_UTIL.CONCAT_LINES

Format

```
SDO_UTIL.CONCAT_LINES(
  geom1 IN SDO_GEOMETRY,
  geom2 IN SDO_GEOMETRY
) RETURN SDO_GEOMETRY;
```

Description

Concatenates two line or multiline two-dimensional geometries to create a new geometry.

Parameters

geom1

First geometry object for the concatenation operation.

geom2

Second geometry object for the concatenation operation.

Usage Notes

Each input geometry must be a two-dimensional line or multiline geometry (that is, the `SDO_GTYPE` value must be 2002 or 2006). This function is not supported for LRS geometries. To concatenate LRS geometric segments, use the [SDO_LRS.CONCATENATE_GEOM_SEGMENTS](#) function (described in [Chapter 25](#)).

The input geometries must be line strings whose vertices are connected by straight line segments. Circular arcs and compound line strings are not supported.

If an input geometry is a multiline geometry, the elements of the geometry must be disjoint. If they are not disjoint, this function may return incorrect results.

The topological relationship between `geom1` and `geom2` must be `DISJOINT` or `TOUCH`; and if the relationship is `TOUCH`, the geometries must intersect only at two end points.

You can use the [SDO_AGGR_CONCAT_LINES](#) spatial aggregate function (described in [Chapter 20](#)) to concatenate multiple two-dimensional line or multiline geometries.

An exception is raised if `geom1` and `geom2` are based on different coordinate systems.

Examples

The following example concatenates two simple line string geometries.

```
-- Concatenate two touching lines: one from (1,1) to (5,1) and the
-- other from (5,1) to (8,1).
SELECT SDO_UTIL.CONCAT_LINES(
  SDO_GEOMETRY(2002, NULL, NULL, SDO_ELEM_INFO_ARRAY(1,2,1),
    SDO_ORDINATE_ARRAY(1,1, 5,1)),
  SDO_GEOMETRY(2002, NULL, NULL, SDO_ELEM_INFO_ARRAY(1,2,1),
    SDO_ORDINATE_ARRAY(5,1, 8,1))
) FROM DUAL;
```

```
SDO_UTIL.CONCAT_LINES(SDO_GEOMETRY(2002,NULL,NULL,SDO_ELEM_INFO_ARRAY(1,2,1),SDO
```

```
-----  
SDO_GEOMETRY(2002, NULL, NULL, SDO_ELEM_INFO_ARRAY(1, 2, 1), SDO_ORDINATE_ARRAY(  
1, 1, 5, 1, 8, 1))
```

Related Topics

- [SDO_AGGR_CONCAT_LINES](#) (in Chapter 20)
- [SDO_LRS.CONCATENATE_GEOM_SEGMENTS](#) (in Chapter 25)

SDO_UTIL.CONVERT_UNIT

Format

```
SDO_UTIL.CONVERT_UNIT(
    input_value IN NUMBER,
    from_unit   IN VARCHAR2,
    to_unit     IN VARCHAR2
) RETURN NUMBER;
```

Description

Converts values from one angle, area, or distance unit of measure to another.

Parameters

input_value

Number of units to be converted. For example, to convert 10 decimal degrees to radians, specify 10.

from_unit

The unit of measure from which to convert the input value. Must be a value from the SDO_UNIT column of the MDSYS.SDO_ANGLE_UNITS table (described in [Section 6.8.2](#)), the MDSYS.SDO_AREA_UNITS table (described in [Section 2.10](#)), or the MDSYS.SDO_DIST_UNITS table (described in [Section 2.10](#)). For example, to convert decimal degrees to radians, specify Degree.

to_unit

The unit of measure into which to convert the input value. Must be a value from the SDO_UNIT column of the same table used for from_unit. For example, to convert decimal degrees to radians, specify Radian.

Usage Notes

The value returned by this function might not be correct at an extremely high degree of precision because of the way internal mathematical operations are performed, especially if they involve small numbers or irrational numbers (such as π). For example, converting 1 decimal degree into decimal minutes results in the value 60.0000017.

Examples

The following example converts 1 radian into decimal degrees.

```
SQL> SELECT SDO_UTIL.CONVERT_UNIT(1, 'Radian', 'Degree') FROM DUAL;

SDO_UTIL.CONVERT_UNIT(1, 'RADIAN', 'DEGREE')
-----
                               57.2957796
```

Related Topics

None.

SDO_UTIL.DROP_WORK_TABLES

Format

```
SDO_UTIL.DROP_WORK_TABLES(  
    oidstr IN VARCHAR2);
```

Description

Drops any transient ("scratch") tables and views in the current schema that were created during the creation of a point cloud or TIN.

Parameters

oidstr

Object ID string representing a hexadecimal number. Use the string given in the error message that indicated that scratch tables need to be dropped.

Usage Notes

If scratch tables still exist from a previous [SDO_PC_PKG.CREATE_PC](#) or [SDO_TIN_PKG.CREATE_TIN](#) operation when you try to create a point cloud or TIN, an error message is displayed indicating that you must first drop the scratch tables. Use the [SDO_UTIL.DROP_WORK_TABLES](#) procedure to drop these scratch tables.

This procedure drops all tables and views that match 'M%_<oidstr>\$\$%'.

Examples

The following example drops the scratch tables from a previous [SDO_PC_PKG.CREATE_PC](#) or [SDO_TIN_PKG.CREATE_TIN](#) operation, using an OID string specified in a previous error message.

```
EXECUTE SDO_UTIL.DROP_WORK_TABLES('A1B2C3');
```

Related Topics

- [SDO_PC_PKG.CREATE_PC](#)
- [SDO_TIN_PKG.CREATE_TIN](#)

SDO_UTIL.ELLIPSE_POLYGON

Format

```
SDO_UTIL.ELLIPSE_POLYGON(  
    center_longitude IN NUMBER,  
    center_latitude  IN NUMBER,  
    semi_major_axis  IN NUMBER,  
    semi_minor_axis  IN NUMBER,  
    azimuth          IN NUMBER,  
    arc_tolerance    IN NUMBER  
) RETURN SDO_GEOMETRY;
```

Description

Returns the polygon geometry that approximates and is covered by a specified ellipse.

Parameters

center_longitude

Center longitude (in degrees) of the ellipse to be used to create the returned geometry.

center_latitude

Center latitude (in degrees) of the ellipse to be used to create the returned geometry.

semi_major_axis

Length (in meters) of the semi-major axis of the ellipse to be used to create the returned geometry.

semi_minor_axis

Length (in meters) of the semi-minor axis of the ellipse to be used to create the returned geometry.

azimuth

Number of degrees of the azimuth (clockwise rotation of the major axis from north) of the ellipse to be used to create the returned geometry. Must be from 0 to 180. The returned geometry is rotated by the specified number of degrees.

arc_tolerance

A numeric value to be used to construct the polygon geometry. The `arc_tolerance` parameter value has the same meaning and usage guidelines as the `arc_tolerance` keyword value in the `params` parameter string for the [SDO_GEOM.SDO_ARC_DENSIFY](#) function. The unit of measurement associated with the geometry is associated with the `arc_tolerance` parameter value. (For more information, see the Usage Notes for the [SDO_GEOM.SDO_ARC_DENSIFY](#) function in [Chapter 24](#).)

Usage Notes

This function is useful for creating an ellipse-like polygon around a specified center point when a true ellipse cannot be used (an ellipse is not valid for geodetic data with Oracle Spatial). The returned geometry has an `SDO_SRID` value of 8307 (for Longitude / Latitude (WGS 84)).

Examples

The following example returns an ellipse-like polygon, oriented east-west (azimuth = 90), around a point near the center of Concord, Massachusetts. An `arc_tolerance` value of 5 meters is used in computing the polygon vertices.

```
SELECT SDO_UTIL.ELLIPSE_POLYGON(-71.34937, 42.46101, 100, 50, 90, 5)
       FROM DUAL;

SDO_UTIL.ELLIPSE_POLYGON(-71.34937,42.46101,100,50,90,5) (SDO_GTYPE, SDO_SRID, SD
-----
SDO_GEOMETRY(2003, 8307, NULL, SDO_ELEM_INFO_ARRAY(1, 1003, 1), SDO_ORDINATE_ARR
AY(-71.350589, 42.46101, -71.350168, 42.4606701, -71.349708, 42.460578, -71.3493
7, 42.4605603, -71.349032, 42.460578, -71.348572, 42.4606701, -71.348151, 42.461
01, -71.348572, 42.4613499, -71.349032, 42.461442, -71.34937, 42.4614597, -71.34
9708, 42.461442, -71.350168, 42.4613499, -71.350589, 42.46101))
```

Related Topics

- [SDO_UTIL.CIRCLE_POLYGON](#)

SDO_UTIL.EXTRACT

Format

```
SDO_UTIL.EXTRACT(
    geometry IN SDO_GEOMETRY,
    element  IN NUMBER,
    ring     IN NUMBER DEFAULT 0
) RETURN SDO_GEOMETRY;
```

Description

Returns the two-dimensional geometry that represents a specified element (and optionally a ring) of the input two-dimensional geometry.

Parameters

geometry

Geometry from which to extract the geometry to be returned. Must be a two-dimensional geometry.

element

Number of the element in the geometry: 1 for the first element, 2 for the second element, and so on. Geometries with SDO_GTYPE values (explained in [Section 2.2.1](#)) ending in 1, 2, or 3 have one element; geometries with SDO_GTYPE values ending in 4, 5, 6, or 7 can have more than one element. For example, a multipolygon with an SDO_GTYPE of 2007 might contain three elements (polygons).

ring

Number of the subelement (ring) within `element`: 1 for the first subelement, 2 for the second subelement, and so on. This parameter is valid only for specifying a subelement of a polygon with one or more holes or of a point cluster:

- For a polygon with holes, its first subelement is its exterior ring, its second subelement is its first interior ring, its third subelement is its second interior ring, and so on. For example, in the polygon with a hole shown in [Figure 2-4](#) in [Section 2.7.2](#), the exterior ring is subelement 1 and the interior ring (the hole) is subelement 2.
- For a point cluster, its first subelement is the first point in the point cluster, its second subelement is the second point in the point cluster, and so on.

The default is 0, which causes the entire element to be extracted.

Usage Notes

This function applies to two-dimensional geometries only. For three-dimensional geometries, use the [SDO_UTIL.EXTRACT3D](#) function.

This function is useful for extracting a specific element or subelement from a complex geometry. For example, if you have identified a geometry as invalid by using the [SDO_GEOM.VALIDATE_GEOMETRY_WITH_CONTEXT](#) function or the [SDO_GEOM.VALIDATE_LAYER_WITH_CONTEXT](#) procedure (both of which are documented in [Chapter 24](#)), you can use the EXTRACT function to extract the invalid geometry in order to examine it.

For a polygon with one or more holes, the returned geometry representing an extracted interior ring is reoriented so that its vertices are presented in counterclockwise order (as opposed to the clockwise order within an interior ring).

If `geometry` is null or has an `SDO_GTYPE` value ending in 0, this function returns a null geometry.

`geometry` cannot contain a type 0 (zero) element. Type 0 elements are described in [Section 2.7.7](#).

This function is not intended for use with geometries that have any null ordinate values. Any null ordinate values in the returned geometry are replaced by 0 (zero).

An exception is raised if `element` or `ring` is an invalid number for `geometry`.

Examples

The following example extracts the first (and only) element in the `cola_c` geometry. (The example uses the definitions and data from [Section 2.1](#).)

```
SELECT c.name, SDO_UTIL.EXTRACT(c.shape, 1)
   FROM cola_markets c WHERE c.name = 'cola_c';

NAME
-----
SDO_UTIL.EXTRACT(C.SHAPE,1)(SDO_GTYPE, SDO_SRID, SDO_POINT(X, Y, Z), SDO_ELEM_IN
-----
cola_c
SDO_GEOMETRY(2003, NULL, NULL, SDO_ELEM_INFO_ARRAY(1, 1003, 1), SDO_ORDINATE_ARR
AY(3, 3, 6, 3, 6, 5, 4, 5, 3, 3))
```

The following example inserts a polygon with a hole (using the same `INSERT` statement as in [Example 2–7](#) in [Section 2.7.2](#)), and extracts the geometry representing the hole (the second subelement). Notice that in the geometry returned by the `EXTRACT` function, the vertices are in counterclockwise order, as opposed to the clockwise order in the hole (second subelement) in the input geometry.

```
-- Insert polygon with hole.
INSERT INTO cola_markets VALUES(
  10,
  'polygon_with_hole',
  SDO_GEOMETRY(
    2003, -- two-dimensional polygon
    NULL,
    NULL,
    SDO_ELEM_INFO_ARRAY(1,1003,1, 19,2003,1), -- polygon with hole
    SDO_ORDINATE_ARRAY(2,4, 4,3, 10,3, 13,5, 13,9, 11,13, 5,13, 2,11, 2,4,
      7,5, 7,10, 10,10, 10,5, 7,5)
  )
);

1 row created.

-- Extract the hole geometry (second subelement).
SELECT SDO_UTIL.EXTRACT(c.shape, 1, 2)
   FROM cola_markets c WHERE c.name = 'polygon_with_hole';

SDO_UTIL.EXTRACT(C.SHAPE,1,2)(SDO_GTYPE, SDO_SRID, SDO_POINT(X, Y, Z), SDO_ELEM_
-----
SDO_GEOMETRY(2003, NULL, NULL, SDO_ELEM_INFO_ARRAY(1, 1003, 1), SDO_ORDINATE_ARR
AY(7, 5, 10, 5, 10, 10, 7, 10, 7, 5))
```

Related Topics

- [SDO_UTIL.EXTRACT3D](#)
- [SDO_UTIL.GETVERTICES](#)
- [SDO_GEOM.VALIDATE_GEOMETRY_WITH_CONTEXT](#)
- [SDO_GEOM.VALIDATE_LAYER_WITH_CONTEXT](#)

SDO_UTIL.EXTRACT_ALL

Format

```
SDO_UTIL.EXTRACT_ALL(  
    geometry IN SDO_GEOMETRY,  
    flatten   IN NUMBER DEFAULT 1  
) RETURN SDO_GEOMETRY_ARRAY;
```

Description

Returns all elements and subelements of the input two-dimensional geometry, as an array of one or more geometries. Returns an object of type `SDO_GEOMETRY_ARRAY`, which is defined as `VARRAY OF SDO_GEOMETRY`.

Parameters

geometry

Geometry from which to extract all elements and subelements. Must be a two-dimensional geometry.

flatten

A flag indicating whether to "flatten" rings into individual geometries for geometries that contain an exterior ring and one or more interior rings:

- 0 (zero) returns one geometry for each element, but does not flatten rings into individual geometries. (A geometry will still be returned for each element of the input geometry.)
- 1 (the default) or any other nonzero value flattens rings into individual geometries.

For example, if a polygon contains an outer ring and an inner ring, a value of 0 returns a single geometry containing both rings, and a value of 1 returns two geometries, each containing a ring as a geometry.

This parameter is ignored for geometries that do not contain an exterior ring and one or more interior rings.

Usage Notes

This function applies to two-dimensional geometries only. For three-dimensional geometries, use the [SDO_UTIL.EXTRACT3D](#) function.

This function enables you to extract all elements and subelements from a geometry, regardless of how many elements and subelements the geometry has. Geometries with `SDO_GTYPE` values (explained in [Section 2.2.1](#)) ending in 1, 2, or 3 have one element; geometries with `SDO_GTYPE` values ending in 4, 5, 6, or 7 can have more than one element. For example, a multipolygon with an `SDO_GTYPE` of 2007 might contain three elements (polygons). To extract individual elements, use the [SDO_UTIL.EXTRACT](#) function instead.

For a polygon with one or more holes, with the default value for the `flatten` parameter, the returned geometry representing an extracted interior ring is reoriented so that its vertices are presented in counterclockwise order (as opposed to the

clockwise order within an interior ring). However, if the `flatten` parameter value is 0, no reorientation is performed.

If `geometry` is null or has an `SDO_GTYPE` value ending in 0, this function returns a null geometry.

`geometry` cannot contain a type 0 (zero) element. Type 0 elements are described in [Section 2.7.7](#).

This function is not intended for use with geometries that have any null ordinate values. Any null ordinate values in the returned geometry are replaced by 0 (zero).

Examples

The following example extracts all elements from the `cola_b` geometry. (The example uses the definitions and data from [Section 2.1](#).)

```
SELECT * FROM TABLE(
  SELECT SDO_UTIL.EXTRACT_ALL(c.shape)
  FROM cola_markets c WHERE c.name = 'cola_b');
```

```
SDO_GTYPE    SDO_SRID
-----
```

```
SDO_POINT(X, Y, Z)
-----
```

```
SDO_ELEM_INFO
-----
```

```
SDO_ORDINATES
-----
```

```
2003
```

```
SDO_ELEM_INFO_ARRAY(1, 1003, 1)
```

```
SDO_ORDINATE_ARRAY(5, 1, 8, 1, 8, 6, 5, 7, 5, 1)
```

The following example inserts a polygon with a hole (using the same INSERT statement as in [Example 2-7](#) in [Section 2.7.2](#)), and extracts all elements and subelements from the `polygon_with_hole` geometry. Notice that because the `flatten` parameter is not specified, in the second geometry returned by the `EXTRACT_ALL` function the vertices are in counterclockwise order, as opposed to the clockwise order in the hole (second subelement) in the input geometry.

```
-- Insert polygon with hole.
INSERT INTO cola_markets VALUES(
  10,
  'polygon_with_hole',
  SDO_GEOMETRY(
    2003, -- two-dimensional polygon
    NULL,
    NULL,
    SDO_ELEM_INFO_ARRAY(1,1003,1, 19,2003,1), -- polygon with hole
    SDO_ORDINATE_ARRAY(2,4, 4,3, 10,3, 13,5, 13,9, 11,13, 5,13, 2,11, 2,4,
      7,5, 7,10, 10,10, 10,5, 7,5)
  )
);
```

```
1 row created.
```

```
-- Extract all, with default for flatten.
```

```
SELECT * FROM TABLE(
  SELECT SDO_UTIL.EXTRACT_ALL(c.shape)
  FROM cola_markets c WHERE c.name = 'polygon_with_hole');
```

```

SDO_GTYPE   SDO_SRID
-----
SDO_POINT(X, Y, Z)
-----
SDO_ELEM_INFO
-----
SDO_ORDINATES
-----
2003

SDO_ELEM_INFO_ARRAY(1, 1003, 1)
SDO_ORDINATE_ARRAY(2, 4, 4, 3, 10, 3, 13, 5, 13, 9, 11, 13, 5, 13, 2, 11, 2, 4)

```

```

SDO_GTYPE   SDO_SRID
-----
SDO_POINT(X, Y, Z)
-----
SDO_ELEM_INFO
-----
SDO_ORDINATES
-----
2003

SDO_ELEM_INFO_ARRAY(1, 1003, 1)
SDO_ORDINATE_ARRAY(7, 5, 10, 5, 10, 10, 7, 10, 7, 5)

```

The following example extracts all elements and subelements from the `polygon_with_hole` geometry (inserted in the preceding example), and it specifies the `flatten` parameter value as 0 (zero). This causes the returned array to contain a single geometry that is the same as the input geometry; thus, in the geometry returned by the `EXTRACT_ALL` function, the vertices are in same clockwise order in the hole (second subelement) as in the input geometry.

```

-- Extract all, with flatten = 0.
SELECT * FROM TABLE(
  SELECT SDO_UTIL.EXTRACT_ALL(c.shape, 0)
    FROM cola_markets c WHERE c.name = 'polygon_with_hole');

```

```

SDO_GTYPE   SDO_SRID
-----
SDO_POINT(X, Y, Z)
-----
SDO_ELEM_INFO
-----
SDO_ORDINATES
-----
2003

SDO_ELEM_INFO_ARRAY(1, 1003, 1, 19, 2003, 1)
SDO_ORDINATE_ARRAY(2, 4, 4, 3, 10, 3, 13, 5, 13, 9, 11, 13, 5, 13, 2, 11, 2, 4,
7, 5, 7, 10, 10, 10, 10, 5, 7, 5)

```

```

SDO_GTYPE   SDO_SRID
-----
SDO_POINT(X, Y, Z)
-----
SDO_ELEM_INFO
-----

```

SDO_ORDINATES

Related Topics

- [SDO_UTIL.EXTRACT](#)

SDO_UTIL.EXTRACT3D

Format

```
SDO_UTIL.EXTRACT3D(  
    geometry IN SDO_GEOMETRY,  
    label IN VARCHAR2  
    ) RETURN SDO_GEOMETRY;
```

Description

Returns the three-dimensional geometry that represents a specified subset of the input three-dimensional geometry.

Parameters

geometry

Geometry from which to extract the geometry to be returned. Must be a three-dimensional geometry

label

A comma-delimited string of numbers that identify the subset geometry to be returned. Each number identifies the relative position of a geometry item within the input geometry. The items and their positions within the `label` string are:

- `pointID`: Point number
- `edgeID`: Edge number
- `ringID`: Ring number
- `polygonID`: Polygon number
- `csurfID`: Composite surface number
- `solidID`: Solid number
- `multiID`: Multisolid number

A value of 0 (zero) means that the item does not apply, and you can omit trailing items that do not apply. For example, '0,2,1,4,1' means that point number does not apply, and it specifies the second edge of the first ring of the fourth polygon of the first composite surface.

Usage Notes

This function applies to three-dimensional geometries only. For two-dimensional geometries, use the [SDO_UTIL.EXTRACT](#) function.

This function uses the `getElementByLabel` method of the `oracle.spatial.geometry.ElementExtractor` Java class, which is described in *Oracle Spatial Java API Reference*.

Examples

The following example extracts, from a specified three-dimensional geometry, the subset geometry consisting of the following: edge 2 of ring 1 of polygon 4 of composite surface 1 of the input geometry.

```

SELECT SDO_UTIL.EXTRACT3D(
  SDO_GEOMETRY (3008,NULL,NULL ,
    SDO_ELEM_INFO_ARRAY(
      1,1007,1,
      1,1006,6,
      1,1003,1,
      16,1003,1,
      31,1003,1,
      46,1003,1,
      61,1003,1,
      76,1003,1),
    SDO_ORDINATE_ARRAY(
      1.0,0.0,-1.0,
      1.0,1.0,-1.0,
      1.0,1.0,1.0,
      1.0,0.0,1.0,
      1.0,0.0,-1.0,
      1.0,0.0,1.0,
      0.0,0.0,1.0,
      0.0,0.0,-1.0,
      1.0,0.0,-1.0,
      1.0,0.0,1.0,
      0.0,1.0,1.0,
      0.0,1.0,-1.0,
      0.0,0.0,-1.0,
      0.0,0.0,1.0,
      0.0,1.0,1.0,
      1.0,1.0,-1.0,
      0.0,1.0,-1.0,
      0.0,1.0,1.0,
      1.0,1.0,1.0,
      1.0,1.0,-1.0,
      1.0,1.0,1.0,
      0.0,1.0,1.0,
      0.0,0.0,1.0,
      1.0,0.0,1.0,
      1.0,1.0,1.0,
      1.0,1.0,-1.0,
      1.0,0.0,-1.0,
      0.0,0.0,-1.0,
      0.0,1.0,-1.0,
      1.0,1.0,-1.0
    )
  ),
  '0,2,1,4,1')
FROM DUAL;

SDO_UTIL.EXTRACT3D(SDO_GEOMETRY(3008,NULL,NULL,SDO_ELEM_INFO_ARRAY(1,1007,1,1,10
-----
SDO_GEOMETRY(3002, NULL, NULL, SDO_ELEM_INFO_ARRAY(1, 2, 1), SDO_ORDINATE_ARRAY(
0, 1, -1, 0, 1, 1))

```

Related Topics

- [SDO_UTIL.EXTRACT](#)

SDO_UTIL.EXTRUDE

Format

```
SDO_UTIL.EXTRUDE(  
    geometry IN SDO_GEOMETRY,  
    grdheight IN SDO_NUMBER_ARRAY,  
    height    IN SDO_NUMBER_ARRAY,  
    tol       IN NUMBER,  
    optional3dSrid IN NUMBER DEFAULT NULL  
) RETURN SDO_GEOMETRY;
```

Description

Returns the three-dimensional extrusion solid geometry from an input two-dimensional polygon geometry.

Parameters

geometry

Two-dimensional polygon geometry from which to return the extrusion geometry. This geometry forms the "base" of the returned geometry.

grdheight

Ground heights as a set of Z (height) values at the base of the solid. The numbers in this array should be the Z (height) values at the base of each vertex in the input geometry.

height

Height values for the extrusion geometry. The numbers in this array should be the Z (height) values at the "top" of each corresponding point in the `grdheight` array. For example, if the ground height at the base of the first vertex is 0 and the height at that vertex is 10, the solid at that point along the base extends 10 units high.

tol

Tolerance value (see [Section 1.5.5](#)).

optional3dSrid

Three-dimensional coordinate system (SRID) to be assigned to the returned geometry. If you do not specify this parameter, Spatial automatically assigns a three-dimensional SRID value based on the SRID value of the input geometry.

Usage Notes

The input geometry must be a two-dimensional polygon geometry.

If the input geometry is a polygon with multiple inner rings, this function internally combines these inner rings to make them one inner ring, producing a new geometry that approximately represents the original appearance; the function then performs the extrusion process on this new geometry, and returns the result.

Examples

The following example returns the three-dimensional solid geometry representing an extrusion from a two-dimensional polygon geometry.

```
SELECT SDO_UTIL.EXTRUDE(
  SDO_GEOMETRY(
    2003,
    null,
    null,
    SDO_ELEM_INFO_ARRAY(1,1003,1),
    SDO_ORDINATE_ARRAY(5, 1,8,1,8,6,5,7,5,1)),
  SDO_NUMBER_ARRAY(0,0,0,0,0),
  SDO_NUMBER_ARRAY(5,10,10,5,5),
  0.005) from dual;

SDO_UTIL.EXTRUDE(SDO_GEOMETRY(2003,NULL,NULL,SDO_ELEM_INFO_ARRAY(1,1003,1),SDO_O
-----
SDO_GEOMETRY(3008, NULL, NULL, SDO_ELEM_INFO_ARRAY(1, 1007, 1, 1, 1006, 6, 1, 10
03, 1, 16, 1003, 1, 31, 1003, 1, 46, 1003, 1, 61, 1003, 1, 76, 1003, 1), SDO_ORD
INATE_ARRAY(5, 1, 0, 5, 7, 0, 8, 6, 0, 8, 1, 0, 5, 1, 0, 5, 1, 5, 8, 1, 10, 8, 6
, 10, 5, 7, 5, 5, 1, 5, 5, 1, 0, 8, 1, 0, 8, 1, 10, 5, 1, 5, 5, 1, 0, 8, 1, 0, 8
, 6, 0, 8, 6, 10, 8, 1, 10, 8, 1, 0, 8, 6, 0, 5, 7, 0, 5, 7, 5, 8, 6, 10, 8, 6,
0, 5, 7, 0, 5, 1, 0, 5, 1, 5, 5, 7, 5, 5, 7, 0))
```

The following example returns the three-dimensional composite solid geometry representing an extrusion from a two-dimensional polygon geometry with inner rings.

```
SELECT SDO_UTIL.EXTRUDE(
  SDO_GEOMETRY(
    2003,
    null,
    null,
    SDO_ELEM_INFO_ARRAY(1, 1003, 1, 11, 2003, 1,
    21, 2003,1, 31,2003,1, 41, 2003, 1),
    SDO_ORDINATE_ARRAY(0,0, 8,0, 8,8, 0,8, 0,0,
    1,3, 1,4, 2,4, 2,3, 1,3, 1,1, 1,2, 2,2, 2,1, 1,1,
    1,6, 1,7, 2,7, 2,6, 1,6, 3,2, 3,4, 4,4, 4,2, 3,2)),
  SDO_NUMBER_ARRAY(-1.0),
  SDO_NUMBER_ARRAY(1.0),
  0.0001) from dual;

SDO_UTIL.EXTRUDE(SDO_GEOMETRY(2003,NULL,NULL,SDO_ELEM_INFO_ARRAY(1,1003,1,11,200
-----
SDO_GEOMETRY(3008, NULL, NULL, SDO_ELEM_INFO_ARRAY(1, 1008, 4, 1, 1007, 1, 1, 10
06, 16, 1, 1003, 1, 46, 1003, 1, 91, 1003, 1, 106, 1003, 1, 121, 1003, 1, 136, 1
003, 1, 151, 1003, 1, 166, 1003, 1, 181, 1003, 1, 196, 1003, 1, 211, 1003, 1, 22
6, 1003, 1, 241, 1003, 1, 256, 1003, 1, 271, 1003, 1, 286, 1003, 1, 301, 1007, 1
, 301, 1006, 10, 301, 1003, 1, 328, 1003, 1, 355, 1003, 1, 370, 1003, 1, 385, 10
03, 1, 400, 1003, 1, 415, 1003, 1, 430, 1003, 1, 445, 1003, 1, 460, 1003, 1, 475
, 1007, 1, 475, 1006, 6, 475, 1003, 1, 490, 1003, 1, 505, 1003, 1, 520, 1003, 1,
535, 1003, 1, 550, 1003, 1, 565, 1007, 1, 565, 1006, 10, 565, 1003, 1, 592, 100
3, 1, 619, 1003, 1, 634, 1003, 1, 649, 1003, 1, 664, 1003, 1, 679, 1003, 1, 694,
1003, 1, 709, 1003, 1, 724, 1003, 1), SDO_ORDINATE_ARRAY(4, 0, -1, 4, 2, -1, 4,
4, -1, 3, 4, -1, 2, 4, -1, 2, 7, -1, 1, 7, -1, 1, 6, -1, 1, 4, -1, 1, 3, -1, 0,
3, -1, 0, 8, -1, 8, 8, -1, 8, 0, -1, 4, 0, -1, 4, 0, 1, 8, 0, 1, 8, 8, 1, 0, 8,
1, 0, 3, 1, 1, 3, 1, 1, 4, 1, 1, 6, 1, 1, 7, 1, 2, 7, 1, 2, 4, 1, 3, 4, 1, 4, 4
, 1, 4, 2, 1, 4, 0, 1, 4, 0, -1, 8, 0, -1, 8, 0, 1, 4, 0, 1, 4, 0, -1, 8, 0, -1,
8, 8, -1, 8, 8, 1, 8, 0, 1, 8, 0, -1, 8, 8, -1, 0, 8, -1, 0, 8, 1, 8, 8, 1, 8,
8, -1, 0, 8, -1, 0, 3, -1, 0, 3, 1, 0, 8, 1, 0, 8, -1, 0, 3, -1, 1, 3, -1, 1, 3,
1, 0, 3, 1, 0, 3, -1, 1, 3, -1, 1, 4, -1, 1, 4, 1, 1, 3, 1, 1, 3, -1, 1, 4, -1,
```

```
1, 6, -1, 1, 6, 1, 1, 4, 1, 1, 4, -1, 1, 6, -1, 1, 7, -1, 1, 7, 1, 1, 6, 1, 1,
6, -1, 1, 7, -1, 2, 7, -1, 2, 7, 1, 1, 7, 1, 1, 7, -1, 2, 7, -1, 2, 4, -1, 2, 4,
1, 2, 7, 1, 2, 7, -1, 2, 4, -1, 3, 4, -1, 3, 4, 1, 2, 4, 1, 2, 4, -1, 3, 4, -1,
4, 4, -1, 4, 4, 1, 3, 4, 1, 3, 4, -1, 4, 4, -1, 4, 2, -1, 4, 2, 1, 4, 4, 1, 4,
4, -1, 4, 2, -1, 4, 0, -1, 4, 0, 1, 4, 2, 1, 4, 2, -1, 0, 3, -1, 1, 3, -1, 1, 1,
-1, 2, 1, -1, 3, 2, -1, 4, 2, -1, 4, 0, -1, 0, 0, -1, 0, 3, -1, 0, 3, 1, 0, 0,
1, 4, 0, 1, 4, 2, 1, 3, 2, 1, 2, 1, 1, 1, 1, 1, 1, 3, 1, 0, 3, 1, 0, 3, -1, 0, 0,
, -1, 0, 0, 1, 0, 3, 1, 0, 3, -1, 0, 0, -1, 4, 0, -1, 4, 0, 1, 0, 0, 1, 0, 0, -1
, 4, 0, -1, 4, 2, -1, 4, 2, 1, 4, 0, 1, 4, 0, -1, 4, 2, -1, 3, 2, -1, 3, 2, 1, 4
, 2, 1, 4, 2, -1, 3, 2, -1, 2, 1, -1, 2, 1, 1, 3, 2, 1, 3, 2, -1, 2, 1, -1, 1, 1
, -1, 1, 1, 1, 2, 1, 1, 2, 1, -1, 1, 1, -1, 1, 3, -1, 1, 3, 1, 1, 1, 1, 1, 1, -1
, 1, 3, -1, 0, 3, -1, 0, 3, 1, 1, 3, 1, 1, 3, -1, 1, 6, -1, 2, 6, -1, 2, 4, -1,
1, 4, -1, 1, 6, -1, 1, 6, 1, 1, 4, 1, 2, 4, 1, 2, 6, 1, 1, 6, 1, 1, 6, -1, 1, 4,
-1, 1, 4, 1, 1, 6, 1, 1, 6, -1, 1, 4, -1, 2, 4, -1, 2, 4, 1, 1, 4, 1, 1, 4, -1,
2, 4, -1, 2, 6, -1, 2, 6, 1, 2, 4, 1, 2, 4, -1, 2, 6, -1, 1, 6, -1, 1, 6, 1, 2,
6, 1, 2, 6, -1, 1, 3, -1, 2, 3, -1, 2, 4, -1, 3, 4, -1, 3, 2, -1, 2, 1, -1, 2,
2, -1, 1, 2, -1, 1, 3, -1, 1, 3, 1, 1, 2, 1, 2, 2, 1, 2, 1, 1, 3, 2, 1, 3, 4, 1,
2, 4, 1, 2, 3, 1, 1, 3, 1, 1, 3, -1, 1, 2, -1, 1, 2, 1, 1, 3, 1, 1, 3, -1, 1, 2
, -1, 2, 2, -1, 2, 2, 1, 1, 2, 1, 1, 2, -1, 2, 2, -1, 2, 1, -1, 2, 1, 1, 2, 2, 1
, 2, 2, -1, 2, 1, -1, 3, 2, -1, 3, 2, 1, 2, 1, 1, 2, 1, -1, 3, 2, -1, 3, 4, -1,
3, 4, 1, 3, 2, 1, 3, 2, -1, 3, 4, -1, 2, 4, -1, 2, 4, 1, 3, 4, 1, 3, 4, -1, 2, 4
, -1, 2, 3, -1, 2, 3, 1, 2, 4, 1, 2, 4, -1, 2, 3, -1, 1, 3, -1, 1, 3, 1, 2, 3, 1
, 2, 3, -1))
```

Related Topics

None.

SDO_UTIL.FROM_GML311GEOMETRY

Format

```
SDO_UTIL.FROM_GML311GEOMETRY(
    geometry IN CLOB,
    srsNamespace IN VARCHAR2 DEFAULT NULL
) RETURN SDO_GEOMETRY;
```

or

```
SDO_UTIL.FROM_GML311GEOMETRY(
    geometry IN VARCHAR2,
    srsNamespace IN VARCHAR2 DEFAULT NULL
) RETURN SDO_GEOMETRY;
```

Description

Converts a geography markup language (GML 3.1.1) fragment to a Spatial geometry object.

Parameters

geometry

Geometry in GML version 3.1.1 format to be converted to SDO_GEOMETRY format.

srsNamespace

(Reserved for Oracle use.)

Usage Notes

The input geometry must be a valid GML fragment describing a GML version 3.1.1 geometry type defined in the Open GIS Implementation Specification.

Examples

The following example shows conversion to and from GML version 3.1.1 format. (The example uses the definitions and data from [Section 2.1](#), specifically the `cola_b` geometry from the `COLA_MARKETS` table.)

```
DECLARE
    gmlgeom CLOB;
    geom_result SDO_GEOMETRY;
    geom SDO_GEOMETRY;
BEGIN
    SELECT c.shape INTO geom FROM cola_markets c WHERE c.name = 'cola_b';

    -- To GML 3.1.1 geometry
    gmlgeom := SDO_UTIL.TO_GML311GEOMETRY(geom);
    DBMS_OUTPUT.PUT_LINE('To GML 3.1.1 geometry result = ' || TO_CHAR(gmlgeom));

    -- From GML 3.1.3 geometry
    geom_result := SDO_UTIL.FROM_GML311GEOMETRY(gmlgeom);

END;
```

```
/
To GML 3.1.1 geometry result = <gml:Polygon srsName="SDO:"
xmlns:gml="http://www.opengis.net/gml"><gml:exterior><gml:LinearRing><gml:posList
srsDimension="2">5.0 1.0 8.0 1.0 8.0 6.0 5.0 7.0 5.0 1.0
</gml:posList></gml:LinearRing></gml:exterior></gml:Polygon>
```

PL/SQL procedure successfully completed.

Related Topics

- [SDO_UTIL.FROM_GMLGEOMETRY](#)
- [SDO_UTIL.TO_GML311GEOMETRY](#)
- [SDO_UTIL.TO_GMLGEOMETRY](#)

SDO_UTIL.FROM_GMLGEOMETRY

Format

```
SDO_UTIL.FROM_GMLGEOMETRY(
    geometry IN CLOB,
    srsNamespace IN VARCHAR2 DEFAULT NULL
) RETURN SDO_GEOMETRY;
```

or

```
SDO_UTIL.FROM_GMLGEOMETRY(
    geometry IN VARCHAR2,
    srsNamespace IN VARCHAR2 DEFAULT NULL
) RETURN SDO_GEOMETRY;
```

Description

Converts a geography markup language (GML 2.0) fragment to a Spatial geometry object.

Parameters

geometry

Geometry in GML version 2.0 format to be converted to SDO_GEOMETRY format.

srsNamespace

(Reserved for Oracle use.)

Usage Notes

The input geometry must be a valid GML fragment describing a GML version 2.0 geometry type defined in the Open GIS Implementation Specification.

Examples

The following example shows conversion to and from GML version 2.0 format. (The example uses the definitions and data from [Section 2.1](#), specifically the `cola_b` geometry from the `COLA_MARKETS` table.)

```
DECLARE
    gmlgeom CLOB;
    geom_result SDO_GEOMETRY;
    geom SDO_GEOMETRY;
BEGIN
    SELECT c.shape INTO geom FROM cola_markets c WHERE c.name = 'cola_b';

    -- To GML geometry
    gmlgeom := SDO_UTIL.TO_GMLGEOMETRY(geom);
    DBMS_OUTPUT.PUT_LINE('To GML geometry result = ' || TO_CHAR(gmlgeom));

    -- From GML geometry
    geom_result := SDO_UTIL.FROM_GMLGEOMETRY(gmlgeom);

END;
```

```
/
To GML geometry result = <gml:Polygon srsName="SDO:"
xmlns:gml="http://www.opengis.net/gml"><gml:outerBoundaryIs><gml:LinearRing><gml
:coordinates decimal="." cs="," ts=" ">5.0,1.0 8.0,1.0 8.0,6.0 5.0,7.0 5.0,1.0
</gml:coordinates></gml:LinearRing></gml:outerBoundaryIs></gml:Polygon>
```

PL/SQL procedure successfully completed.

Related Topics

- [SDO_UTIL.FROM_GML311GEOMETRY](#)
- [SDO_UTIL.TO_GML311GEOMETRY](#)
- [SDO_UTIL.TO_GMLGEOMETRY](#)

SDO_UTIL.FROM_KMLGEOMETRY

Format

```
SDO_UTIL.FROM_KMLGEOMETRY(
    geometry IN CLOB
) RETURN SDO_GEOMETRY;
```

or

```
SDO_UTIL.FROM_KMLGEOMETRY(
    geometry IN VARCHAR2
) RETURN SDO_GEOMETRY;
```

Description

Converts a KML (Keyhole Markup Language) document to a Spatial geometry object.

Parameters

geometry

Geometry in KML format of type CLOB or VARCHAR2 to be converted to SDO_GEOMETRY format.

Usage Notes

The input geometry must be a valid document conforming to the KML 2.1 specification.

Examples

The following example shows conversion to and from KML format. (The example uses the definitions and data from [Section 2.1](#), specifically the `cola_c` geometry from the `COLA_MARKETS` table.)

```
-- Convert cola_c geometry to a KML document; convert that result to
-- a spatial geometry.
DECLARE
    kmlgeom CLOB;
    val_result VARCHAR2(5);
    geom_result SDO_GEOMETRY;
    geom SDO_GEOMETRY;
BEGIN
    SELECT c.shape INTO geom FROM cola_markets c WHERE c.name = 'cola_c';

    -- To KML geometry
    kmlgeom := SDO_UTIL.TO_KMLGEOMETRY(geom);
    DBMS_OUTPUT.PUT_LINE('To KML geometry result = ' || TO_CHAR(kmlgeom));

    -- From KML geometry
    geom_result := SDO_UTIL.FROM_KMLGEOMETRY(kmlgeom);
    -- Validate the returned geometry
    val_result := SDO_GEOM.VALIDATE_GEOMETRY_WITH_CONTEXT(geom_result, 0.005);
    DBMS_OUTPUT.PUT_LINE('Validation result = ' || val_result);

END;
```

```
/
To KML geometry result =
<Polygon><extrude>0</extrude><tessellate>0</tessellate><altitudeMode>relativeToG
round</altitudeMode><outerBoundaryIs><LinearRing><coordinates>3.0,3.0 6.0,3.0
6.0,5.0 4.0,5.0 3.0,3.0 </coordinates></LinearRing></outerBoundaryIs></Polygon>
Validation result = TRUE
```

Related Topics

- [SDO_UTIL.TO_KMLGEOMETRY](#)

SDO_UTIL.FROM_WKBGEOMETRY

Format

```
SDO_UTIL.FROM_WKBGEOMETRY(
    geometry IN BLOB
) RETURN SDO_GEOMETRY;
```

Description

Converts a geometry in the well-known binary (WKB) format to a Spatial geometry object.

Parameters

geometry

Geometry in WKB format to be converted to SDO_GEOMETRY format.

Usage Notes

The input geometry must be in the well-known binary (WKB) format, as defined by the Open Geospatial Consortium and the International Organization for Standardization (ISO).

This function is patterned after the SQL Multimedia recommendations in *ISO 13249-3, Information technology - Database languages - SQL Multimedia and Application Packages - Part 3: Spatial*.

To convert an SDO_GEOMETRY object to WKB format, use the [SDO_UTIL.TO_WKBGEOMETRY](#) function.

Examples

The following example shows conversion to and from WKB and WKT format, and validation of WKB and WKT geometries. (The example uses the definitions and data from [Section 2.1](#), specifically the `cola_b` geometry from the `COLA_MARKETS` table.)

```
DECLARE
    wkbgeom BLOB;
    wktgeom CLOB;
    val_result VARCHAR2(5);
    geom_result SDO_GEOMETRY;
    geom SDO_GEOMETRY;
BEGIN
    SELECT c.shape INTO geom FROM cola_markets c WHERE c.name = 'cola_b';

    -- To WBT/WKT geometry
    wkbgeom := SDO_UTIL.TO_WKBGEOMETRY(geom);
    wktgeom := SDO_UTIL.TO_WKTGEOMETRY(geom);
    DBMS_OUTPUT.PUT_LINE('To WKT geometry result = ' || TO_CHAR(wktgeom));

    -- From WBT/WKT geometry
    geom_result := SDO_UTIL.FROM_WKBGEOMETRY(wkbgeom);
    geom_result := SDO_UTIL.FROM_WKTGEOMETRY(wktgeom);

    -- Validate WBT/WKT geometry
    val_result := SDO_UTIL.VALIDATE_WKBGEOMETRY(wkbgeom);
```

```
DBMS_OUTPUT.PUT_LINE('WKB validation result = ' || val_result);
val_result := SDO_UTIL.VALIDATE_WKTGEOMETRY(wktgeom);
DBMS_OUTPUT.PUT_LINE('WKT validation result = ' || val_result);

END;
/
```

```
To WKT geometry result = POLYGON ((5.0 1.0, 8.0 1.0, 8.0 6.0, 5.0 7.0, 5.0 1.0))
WKB validation result = TRUE
WKT validation result = TRUE
```

Related Topics

- [SDO_UTIL.FROM_WKTGEOMETRY](#)
- [SDO_UTIL.TO_WKBGEOMETRY](#)
- [SDO_UTIL.TO_WKTGEOMETRY](#)
- [SDO_UTIL.VALIDATE_WKBGEOMETRY](#)
- [SDO_UTIL.VALIDATE_WKTGEOMETRY](#)

SDO_UTIL.FROM_WKTGEOMETRY

Format

```
SDO_UTIL.FROM_WKTGEOMETRY(
    geometry IN CLOB
) RETURN SDO_GEOMETRY;
```

or

```
SDO_UTIL.FROM_WKTGEOMETRY(
    geometry IN VARCHAR2
) RETURN SDO_GEOMETRY;
```

Description

Converts a geometry in the well-known text (WKT) format to a Spatial geometry object.

Parameters

geometry

Geometry in WKT format to be converted to SDO_GEOMETRY format.

Usage Notes

The input geometry must be in the well-known text (WKT) format, as defined by the Open Geospatial Consortium and the International Organization for Standardization (ISO).

This function is patterned after the SQL Multimedia recommendations in *ISO 13249-3, Information technology - Database languages - SQL Multimedia and Application Packages - Part 3: Spatial*.

To convert an SDO_GEOMETRY object to a CLOB in WKT format, use the [SDO_UTIL.TO_WKTGEOMETRY](#) function. (You can use the SQL function TO_CHAR to convert the resulting CLOB to VARCHAR2 type.)

Examples

The following example shows conversion to and from WKB and WKT format, and validation of WKB and WKT geometries. (The example uses the definitions and data from [Section 2.1](#), specifically the cola_b geometry from the COLA_MARKETS table.)

```
DECLARE
    wkbgeom BLOB;
    wktgeom CLOB;
    val_result VARCHAR2(5);
    geom_result SDO_GEOMETRY;
    geom SDO_GEOMETRY;
BEGIN
    SELECT c.shape INTO geom FROM cola_markets c WHERE c.name = 'cola_b';

    -- To WBT/WKT geometry
    wkbgeom := SDO_UTIL.TO_WKBGEOMETRY(geom);
    wktgeom := SDO_UTIL.TO_WKTGEOMETRY(geom);
    DBMS_OUTPUT.PUT_LINE('To WKT geometry result = ' || TO_CHAR(wktgeom));
```

```
-- From WBT/WKT geometry
geom_result := SDO_UTIL.FROM_WKBGEOMETRY(wkbgeom);
geom_result := SDO_UTIL.FROM_WKTGEOMETRY(wktgeom);

-- Validate WBT/WKT geometry
val_result := SDO_UTIL.VALIDATE_WKBGEOMETRY(wkbgeom);
DBMS_OUTPUT.PUT_LINE('WKB validation result = ' || val_result);
val_result := SDO_UTIL.VALIDATE_WKTGEOMETRY(wktgeom);
DBMS_OUTPUT.PUT_LINE('WKT validation result = ' || val_result);

END;
/

To WKT geometry result = POLYGON ((5.0 1.0, 8.0 1.0, 8.0 6.0, 5.0 7.0, 5.0 1.0))
WKB validation result = TRUE
WKT validation result = TRUE
```

Related Topics

- [SDO_UTIL.FROM_WKBGEOMETRY](#)
- [SDO_UTIL.TO_WKBGEOMETRY](#)
- [SDO_UTIL.TO_WKTGEOMETRY](#)
- [SDO_UTIL.VALIDATE_WKBGEOMETRY](#)
- [SDO_UTIL.VALIDATE_WKTGEOMETRY](#)

SDO_UTIL.GETNUMELEM

Format

```
SDO_UTIL.GETNUMELEM(
    geometry IN SDO_GEOMETRY
) RETURN NUMBER;
```

Description

Returns the number of elements in the input geometry.

Parameters

geometry
Geometry for which to return the number of elements.

Usage Notes

None.

Examples

The following example returns the number of elements for each geometry in the SHAPE column of the COLA_MARKETS table. (The example uses the definitions and data from [Section 2.1](#).)

```
SELECT c.name, SDO_UTIL.GETNUMELEM(c.shape)
FROM cola_markets c;
```

NAME	SDO_UTIL.GETNUMELEM(C.SHAPE)
cola_a	1
cola_b	1
cola_c	1
cola_d	1

Related Topics

- [SDO_UTIL.GETNUMVERTICES](#)

SDO_UTIL.GETNUMVERTICES

Format

```
SDO_UTIL.GETNUMVERTICES(  
    geometry IN SDO_GEOMETRY  
    ) RETURN NUMBER;
```

Description

Returns the number of vertices in the input geometry.

Parameters

geometry
Geometry for which to return the number of vertices.

Usage Notes

None.

Examples

The following example returns the number of vertices for each geometry in the SHAPE column of the COLA_MARKETS table. (The example uses the definitions and data from [Section 2.1](#).)

```
SELECT c.name, SDO_UTIL.GETNUMVERTICES(c.shape)  
    FROM cola_markets c;
```

NAME	SDO_UTIL.GETNUMVERTICES(C.SHAPE)
cola_a	2
cola_b	5
cola_c	5
cola_d	3

Related Topics

- [SDO_UTIL.GETVERTICES](#)
- [SDO_UTIL.GETNUMELEM](#)

SDO_UTIL.GETVERTICES

Format

```
SDO_UTIL.GETVERTICES(
    geometry IN SDO_GEOMETRY
) RETURN VERTEX_SET_TYPE;
```

Description

Returns the coordinates of the vertices of the input geometry.

Parameters

geometry

Geometry for which to return the coordinates of the vertices.

Usage Notes

This function returns an object of MDSYS.VERTEX_SET_TYPE, which consists of a table of objects of MDSYS.VERTEX_TYPE. Oracle Spatial defines the type VERTEX_SET_TYPE as:

```
CREATE TYPE vertex_set_type as TABLE OF vertex_type;
```

Oracle Spatial defines the object type VERTEX_TYPE as:

```
CREATE TYPE vertex_type AS OBJECT
(x NUMBER,
 y NUMBER,
 z NUMBER,
 w NUMBER,
 v5 NUMBER,
 v6 NUMBER,
 v7 NUMBER,
 v8 NUMBER,
 v9 NUMBER,
 v10 NUMBER,
 v11 NUMBER,
 id NUMBER);
```

Note: The VERTEX_SET_TYPE and VERTEX_TYPE types are intended for use by Oracle only. Do not use these types in column definitions or functions that you create.

This function can be useful in finding a vertex that is causing a geometry to be invalid. For example, if you have identified a geometry as invalid by using the [SDO_GEOM.VALIDATE_GEOMETRY_WITH_CONTEXT](#) function or the [SDO_GEOM.VALIDATE_LAYER_WITH_CONTEXT](#) procedure (both of which are documented in [Chapter 24](#)), you can use the GETVERTICES function to view the vertices in tabular format.

Examples

The following example returns the X and Y coordinates and ID values of the vertices of the geometries in the SHAPE column of the COLA_MARKETS table. (The example uses the definitions and data from [Section 2.1](#).)

```
SELECT c.mkt_id, c.name, t.X, t.Y, t.id
   FROM cola_markets c,
   TABLE(SDO_UTIL.GETVERTICES(c.shape)) t
  ORDER BY c.mkt_id, t.id;
```

MKT_ID	NAME	X	Y	ID
1	cola_a	1	1	1
1	cola_a	5	7	2
2	cola_b	5	1	1
2	cola_b	8	1	2
2	cola_b	8	6	3
2	cola_b	5	7	4
2	cola_b	5	1	5
3	cola_c	3	3	1
3	cola_c	6	3	2
3	cola_c	6	5	3
3	cola_c	4	5	4
3	cola_c	3	3	5
4	cola_d	8	7	1
4	cola_d	10	9	2
4	cola_d	8	11	3

15 rows selected.

Related Topics

- [SDO_UTIL.EXTRACT](#)
- [SDO_GEOM.VALIDATE_GEOMETRY_WITH_CONTEXT](#)
- [SDO_GEOM.VALIDATE_LAYER_WITH_CONTEXT](#)
- [SDO_UTIL.GETNUMVERTICES](#)

SDO_UTIL.INITIALIZE_INDEXES_FOR_TTS

Format

```
SDO_UTIL.INITIALIZE_INDEXES_FOR_TTS;
```

Description

Initializes all spatial indexes in a tablespace that was transported to another database.

Parameters

None.

Usage Notes

This procedure is part of the support for using the Oracle transportable tablespace feature with tablespaces that contain any spatial indexes. Use this procedure only either (A) the import operation of pre-Release 11.2 dump files is completed, or (B) after the import operation from different endian platform in Release 11.2 or later is completed. Each user that has a spatial index in the tablespace must call the procedure.

For pre-Release 11.2 dump files, after calling the SDO_UTIL.INITIALIZE_INDEXES_FOR_TTS procedure, you must execute a statement in the following format for each index that is in the imported transportable tablespace:

```
ALTER INDEX spatial-index-from-imported-tts PARAMETERS ('CLEAR_TTS=TRUE');
```

For detailed information about transportable tablespaces and transporting tablespaces to other databases, see *Oracle Database Administrator's Guide*.

Examples

The following example for an import of pre-Release 11.2 dump files initializes all spatial indexes in a tablespace that was transported to another database. It also includes the required ALTER INDEX statement for two hypothetical spatial indexes.

```
CALL SDO_UTIL.INITIALIZE_INDEXES_FOR_TTS;
ALTER INDEX xyz1_spatial_idx PARAMETERS ('CLEAR_TTS=TRUE');
ALTER INDEX xyz2_spatial_idx PARAMETERS ('CLEAR_TTS=TRUE');
```

In the following example, the owner of the spatial index must call the SDO_UTIL.INITIALIZE_INDEXES_FOR_TTS procedure only if the SELECT statement returns the string Y, to reflect the fact that the spatial indexes are imported from different endian platforms in Release 11.2.

```
SELECT DECODE(BITAND(sdo_index_version, 1024), 1024, 'Y', 'N') ENDIAN_FLAG
  FROM user_sdo_index_metadata
  WHERE sdo_index_name = :index_name;
-- If the result is 'Y', perform the next statement.
CALL SDO_UTIL.INITIALIZE_INDEXES_FOR_TTS;
-- No ALTER INDEX statements are needed.
```

In this example, if you call the SDO_UTIL.INITIALIZE_INDEXES_FOR_TTS procedure when the SELECT statement returns the string N, the procedure does nothing because there is no need to perform endian conversion.

Related Topics

None.

SDO_UTIL.INTERIOR_POINT

Format

```
SDO_UTIL.INTERIOR_POINT(
    geom IN SDO_GEOMETRY,
    tol   IN NUMBER DEFAULT 0.0000000005
) RETURN SDO_GEOMETRY;
```

Description

Returns a point that is guaranteed to be an interior point (not on the boundary or edge) on the surface of a polygon geometry object.

Parameters

geom

Polygon geometry object. The `SDO_GTYPE` value of the geometry must be 2003 or 2007. (`SDO_GTYPE` values are explained in [Section 2.2.1](#).)

tol

Tolerance value (see [Section 1.5.5](#)).

Usage Notes

This function returns a point geometry object representing a point that is guaranteed to be an interior point on the surface, but not on the boundary or edge, of `geom`. The returned point can be any interior point on the surface; however, if you call the function multiple times with the same `geom` and `tol` parameter values, the returned point will be the same.

The relationship between the returned point and the original geometry is `INSIDE`, which you can check using the [SDO_RELATE](#) operator with `'mask=inside'`.

In most cases this function is more useful than the [SDO_GEOM.SDO_POINTONSURFACE](#) function, which returns a point that is not guaranteed to be an interior point.

Examples

The following example returns a geometry object that is an interior point on the surface of `cola_a`. (The example uses the definitions and data from [Section 2.1](#).)

```
-- Return an interior point on the surface of a geometry.
SELECT SDO_UTIL.INTERIOR_POINT(c.shape, 0.005)
       FROM cola_markets c
       WHERE c.name = 'cola_a';

SDO_UTIL.INTERIOR_POINT(C.SHAPE,0.005) (SDO_GTYPE, SDO_SRID, SDO_POINT(X, Y, Z),
-----
SDO_GEOMETRY(2001, NULL, SDO_POINT_TYPE(2.75, 2.875, NULL), NULL, NULL)
```

Related Topics

None.

SDO_UTIL.POINT_AT_BEARING

Format

```
SDO_UTIL.POINT_AT_BEARING(
    start_point IN SDO_GEOMETRY,
    bearing     IN NUMBER,
    distance    IN NUMBER
) RETURN SDO_GEOMETRY;
```

Description

Returns a point geometry that is at the specified distance and bearing from the start point.

Parameters

start_point

Point geometry object from which to compute the distance at the specified bearing, to locate the desired point. The point geometry must be based on a geodetic coordinate system.

bearing

Number of radians, measured clockwise from North. Must be in the range of either $-pi$ to pi or 0 to $2*pi$. (Either convention on ranges will work).

distance

Number of meters from `start_point` and along the initial bearing direction to the computed destination point. Must be less than one-half the circumference of the Earth.

Usage Notes

The input point geometry must be based on a geodetic coordinate system. If it is based on a non-geodetic coordinate system, this function returns a null value.

To convert decimal degrees to radians or nonmetric distances to meters, you can use the [SDO_UTIL.CONVERT_UNIT](#) function. To compute the bearing and tilt from a start point to an end point, you can use the [SDO_UTIL.BEARING_TILT_FOR_POINTS](#) procedure.

Examples

The following example returns the point 100 kilometers at a bearing of 1 radian from the point with the longitude and latitude coordinates (-72, 43).

```
SELECT SDO_UTIL.POINT_AT_BEARING (
    SDO_GEOMETRY(2001, 8307,
        SDO_POINT_TYPE(-72, 43, NULL), NULL, NULL),
    1, -- 1 radian (57.296 degrees clockwise from North)
    100000 -- 100 kilometers
) FROM DUAL;

SDO_UTIL.POINT_AT_BEARING(SDO_GEOMETRY(2001,8307,SDO_POINT_TYPE(-72,43,NULL),NUL
-----
SDO_GEOMETRY(2001, 8307, NULL, SDO_ELEM_INFO_ARRAY(1, 1, 1), SDO_ORDINATE_ARRAY(
```

-70.957053, 43.4811935))

Related Topics

- [SDO_UTIL.BEARING_TILT_FOR_POINTS](#)
- [SDO_UTIL.CONVERT_UNIT](#)

SDO_UTIL.POLYGONTOLINE

Format

```
SDO_UTIL.POLYGONTOLINE(
    geometry IN SDO_GEOMETRY
) RETURN SDO_GEOMETRY;
```

Description

Converts all polygon-type elements in a geometry to line-type elements, and sets the SDO_GTYPE value accordingly.

Parameters

geometry
Geometry to convert.

Usage Notes

The order of the vertices of each resulting line-type element is the same as in the associated polygon-type element, and the start and end points of each line-type segment are the same point.

If the input geometry is a line, it is returned.

Examples

The following example converts the input polygon geometry, which is the same geometry as `cola_b` (see [Figure 2-1](#) and [Example 2-1](#) in [Section 2.1](#)), to a line string geometry. In the returned geometry, the SDO_GTYPE value (2002) indicates a two-dimensional LINE geometry, and the SDO_ETYPE value (2) and SDO_INTERPRETATION value (1) in the SDO_ELEM_INFO array indicate a line string whose vertices are connected by straight line segments.

```
SELECT SDO_UTIL.POLYGONTOLINE(
    SDO_GEOMETRY(
        2003, -- two-dimensional polygon
        NULL,
        NULL,
        SDO_ELEM_INFO_ARRAY(1,1003,1), -- one polygon (exterior polygon ring)
        SDO_ORDINATE_ARRAY(5,1, 8,1, 8,6, 5,7, 5,1)
    )
) FROM DUAL;
```

```
SDO_UTIL.POLYGONTOLINE(SDO_GEOMETRY(2003, --TWO-DIMENSIONALPOLYGONNULL, NULL, SDO_E
-----
SDO_GEOMETRY(2002, NULL, NULL, SDO_ELEM_INFO_ARRAY(1, 2, 1), SDO_ORDINATE_ARRAY(
5, 1, 8, 1, 8, 6, 5, 7, 5, 1))
```

Related Topics

None.

SDO_UTIL.PREPARE_FOR_TTS

Format

```
SDO_UTIL.PREPARE_FOR_TTS(  
    table_space IN VARCHAR2);
```

Description

(Deprecated feature. Previous usage was: "Prepares a tablespace to be transported to another database, so that spatial indexes will be preserved during the transport operation.")

Parameters

table_space

Tablespace to be transported. Must be the tablespace containing the spatial table or tables. For a partitioned table, must be the tablespace of one of the partitions.

Usage Notes

Effective with Oracle Database Release 11.2, this procedure is deprecated. You do not need to call the PREPARE_FOR_TTS procedure before performing a transportable tablespace export operation.

For detailed information about transportable tablespaces and transporting tablespaces to other databases, see *Oracle Database Administrator's Guide*.

Examples

None.

Related Topics

- [SDO_UTIL.INITIALIZE_INDEXES_FOR_TTS](#)

SDO_UTIL.RECTIFY_GEOMETRY

Format

```
SDO_UTIL.RECTIFY_GEOMETRY(  
    geometry IN SDO_GEOMETRY,  
    tolerance IN NUMBER  
    ) RETURN SDO_GEOMETRY;
```

Description

Fixes certain problems with the input geometry, and returns a valid geometry.

Parameters

geometry

Geometry to be checked for problems that can be fixed.

tolerance

Tolerance value (see [Section 1.5.5](#)).

Usage Notes

This function checks for the following problems that can make a geometry invalid, and fixes the problems in the returned geometry:

- Duplicate vertices
- Polygon boundary intersecting itself
- Incorrect orientation of exterior or interior rings (or both) of a polygon

If the input geometry has any other problem that makes it invalid, the function raises an exception.

If the input geometry is valid, the function returns a geometry that is identical to the input geometry.

For information about using this function as part of the recommended procedure for loading and validating spatial data, see [Section 4.3](#).

This function is used internally by the [SDO_UTIL.SIMPLIFY](#) function as part of the geometry simplification process.

Examples

The following example checks the `cola_b` geometry to see if it has problems that can be fixed. (In this case, the geometry is valid, so the input geometry is returned. The example uses the definitions and data from [Section 2.1](#).)

```
SELECT SDO_UTIL.RECTIFY_GEOMETRY(shape, 0.005)  
    FROM COLA_MARKETS c WHERE c.name = 'cola_b';  
  
SDO_UTIL.RECTIFY_GEOMETRY(SHAPE,0.005)(SDO_GTYPE, SDO_SRID, SDO_POINT(X, Y, Z),  
-----  
SDO_GEOMETRY(2003, NULL, NULL, SDO_ELEM_INFO_ARRAY(1, 1003, 1), SDO_ORDINATE_ARR  
AY(5, 1, 8, 1, 8, 6, 5, 7, 5, 1))
```

Related Topics

[SDO_UTIL.RECTIFY_GEOMETRY](#)

SDO_UTIL.REMOVE_DUPLICATE_VERTICES

Format

```
SDO_UTIL.REMOVE_DUPLICATE_VERTICES
  geometry IN SDO_GEOMETRY,
  tolerance IN NUMBER
  ) RETURN SDO_GEOMETRY;
```

Description

Removes duplicate (redundant) vertices from a geometry.

Parameters

geometry

Geometry from which to remove duplicate vertices.

tolerance

Tolerance value (see [Section 1.5.5](#)).

Usage Notes

When two consecutive vertices in a geometry are the same or within the tolerance value associated with the geometry, Spatial considers the geometry to be invalid. The Spatial geometry validation functions return the error ORA-13356 in these cases. You can use the REMOVE_DUPLICATE_VERTICES function to change such invalid geometries into valid geometries.

This function also closes polygons so that the first vertex of the ring is the same as the last vertex of the ring.

This function is not supported for any point geometries (including oriented points).

If the input geometry does not contain any duplicate vertices, it is returned.

Examples

The following example removes a duplicate vertex from the input geometry, which is the same geometry as cola_b (see [Figure 2-1](#) and [Example 2-1](#) in [Section 2.1](#)) except that it has been deliberately made invalid by adding a third vertex that is the same point as the second vertex (8,1).

```
SELECT SDO_UTIL.REMOVE_DUPLICATE_VERTICES (
  SDO_GEOMETRY(
    2003, -- two-dimensional polygon
    NULL,
    NULL,
    SDO_ELEM_INFO_ARRAY(1,1003,1), -- one polygon (exterior polygon ring)
    SDO_ORDINATE_ARRAY(5,1, 8,1, 8,1, 8,6, 5,7, 5,1) -- 2nd and 3rd points
    -- are duplicates.
  ),
  0.005 -- tolerance value
) FROM DUAL;

SDO_UTIL.REMOVE_DUPLICATE_VERTICES(SDO_GEOMETRY(2003,--TWO-DIMENSIONALPOLYGONNUL
-----
```



```
SDO_GEOMETRY(2003, NULL, NULL, SDO_ELEM_INFO_ARRAY(1, 1003, 1), SDO_ORDINATE_ARRAY(5, 1, 8, 1, 8, 6, 5, 7, 5, 1))
```

Related Topics

None.

SDO_UTIL.REVERSE_LINestring

Format

```
SDO_UTIL.REVERSE_LINestring(  
    geometry IN SDO_GEOMETRY  
    ) RETURN SDO_GEOMETRY;
```

Description

Returns a line string geometry with the vertices of the input geometry in reverse order.

Parameters

geometry

Line string geometry whose vertices are to be reversed in the output geometry. The SDO_GTYPE value of the input geometry must be 2002. ([Section 2.2.1](#) explains SDO_GTYPE values.)

Usage Notes

Because the SDO_GTYPE value of the input geometry must be 2002, this function cannot be used to reverse LRS geometries. To reverse an LRS geometry, use the [SDO_LRS.REVERSE_GEOMETRY](#) function, which is described in [Chapter 25](#).

Examples

The following example returns a line string geometry that reverses the vertices of the input geometry.

```
SELECT SDO_UTIL.REVERSE_LINestring(  
    SDO_GEOMETRY(2002, 8307, NULL, SDO_ELEM_INFO_ARRAY(1,2,1),  
    SDO_ORDINATE_ARRAY(-72,43, -71.5,43.5, -71,42, -70,40))  
    ) FROM DUAL;  
  
SDO_UTIL.REVERSE_LINestring(SDO_GEOMETRY(2002,8307,NULL,SDO_ELEM_INFO_ARRAY(1,2,  
-----  
SDO_GEOMETRY(2002, 8307, NULL, SDO_ELEM_INFO_ARRAY(1, 2, 1), SDO_ORDINATE_ARRAY(  
-70, 40, -71, 42, -71.5, 43.5, -72, 43))
```

Related Topics

- [SDO_LRS.REVERSE_GEOMETRY](#) (in [Chapter 25](#))

SDO_UTIL.SIMPLIFY

Format

```
SDO_UTIL.SIMPLIFY(  
    geometry IN SDO_GEOMETRY,  
    threshold IN NUMBER  
    tolerance IN NUMBER DEFAULT 0.0000005  
) RETURN SDO_GEOMETRY;
```

Description

Simplifies the input geometry, based on a threshold value, using the Douglas-Peucker algorithm.

Parameters

geometry

Geometry to be simplified.

threshold

Threshold value to be used for the geometry simplification. Should be a positive number. (Zero causes the input geometry to be returned.) If the input geometry is geodetic, the value is the number of meters; if the input geometry is non-geodetic, the value is the number of units associated with the data.

As the threshold value is decreased, the returned geometry is likely to be closer to the input geometry; as the threshold value is increased, fewer points are likely to be in the returned geometry. See the Usage Notes for more information.

tolerance

Tolerance value (see [Section 1.5.5](#)). Must not be greater than `threshold`; and for better performance, should not be the same as `threshold`. If you do not specify a value, the default value is 0.0000005.

Usage Notes

This function also convert arcs to line stings, eliminates duplicate vertices, and corrects many overlapping edge polygon problems. The reason this function sometimes fixes problems is that it internally calls the [SDO_UTIL.RECTIFY_GEOMETRY](#) function at the end of the simplification process to ensure that a valid geometry is returned.

This function is useful when you want a geometry with less fine resolution than the original geometry. For example, if the display resolution cannot show the hundreds or thousands of turns in the course of a river or in a political boundary, better performance might result if the geometry were simplified to show only the major turns.

If you use this function with geometries that have more than two dimensions, only the first two dimensions are used in processing the query, and only the first two dimensions in the returned geometry are to be considered valid and meaningful. For example, the measure values in a returned LRS geometry will probably not reflect actual measures in that geometry. In this case, depending on your application needs,

you might have several options after the simplification operation, such as ignoring the new measure values or redefining the new LRS geometry to reset the measure values.

This function uses the Douglas-Peucker algorithm, which is explained in several cartography textbooks and reference documents. (In some explanations, the term *tolerance* is used instead of *threshold*; however, this is different from the Oracle Spatial meaning of tolerance.)

The returned geometry can be a polygon, line, or point, depending on the geometry definition and the threshold value. The following considerations apply:

- A polygon can simplify to a line or a point and a line can simplify to a point, if the threshold value associated with the geometry is sufficiently large. For example, a thin rectangle will simplify to a line if the distance between the two parallel long sides is less than the threshold value, and a line will simplify to a point if the distance between the start and end points is less than the threshold value.
- In a polygon with a hole, if the exterior ring or the interior ring (the hole) simplifies to a line or a point, the interior ring disappears from (is not included in) the resulting geometry.
- Topological characteristics of the input geometry might not be maintained after simplification. For a collection geometry, the number of elements might increase, to prevent overlapping of individual elements. In all cases, this function will not return an invalid geometry.

Examples

The following example simplifies the road shown in [Figure 7–20](#) in [Section 7.7](#). Because the threshold value (6) is fairly large given the input geometry, the resulting LRS line string has only three points: the start and end points, and (12, 4,12). The measure values in the returned geometry are not meaningful, because this function considers only two dimensions.

```
SELECT SDO_UTIL.SIMPLIFY(
  SDO_GEOMETRY(
    3302, -- line string, 3 dimensions (X,Y,M), 3rd is linear ref. dimension
    NULL,
    NULL,
    SDO_ELEM_INFO_ARRAY(1,2,1), -- one line string, straight segments
    SDO_ORDINATE_ARRAY(
      2,2,0, -- Starting point - Exit1; 0 is measure from start.
      2,4,2, -- Exit2; 2 is measure from start.
      8,4,8, -- Exit3; 8 is measure from start.
      12,4,12, -- Exit4; 12 is measure from start.
      12,10,NULL, -- Not an exit; measure automatically calculated and filled.
      8,10,22, -- Exit5; 22 is measure from start.
      5,14,27) -- Ending point (Exit6); 27 is measure from start.
    ),
  6, -- threshold value for geometry simplification
  0.5 -- tolerance
) FROM DUAL;

SDO_UTIL.SIMPLIFY(SDO_GEOMETRY(3302,--LINESTRING,3DIMENSIONS(X,Y,M),3RDISLINEARR
-----
SDO_GEOMETRY(3302, NULL, NULL, SDO_ELEM_INFO_ARRAY(1, 2, 1), SDO_ORDINATE_ARRAY(
2, 2, 0, 12, 4, 12, 5, 14, 27))
```

[Figure 32–1](#) shows the result of this example. In [Figure 32–1](#), the thick solid black line is the resulting geometry, the thin solid light line between the start and end points is

the input geometry, and the thin dashed line with the arrowhead at the end shows the direction of the segment.

Figure 32-1 Simplification of a Geometry

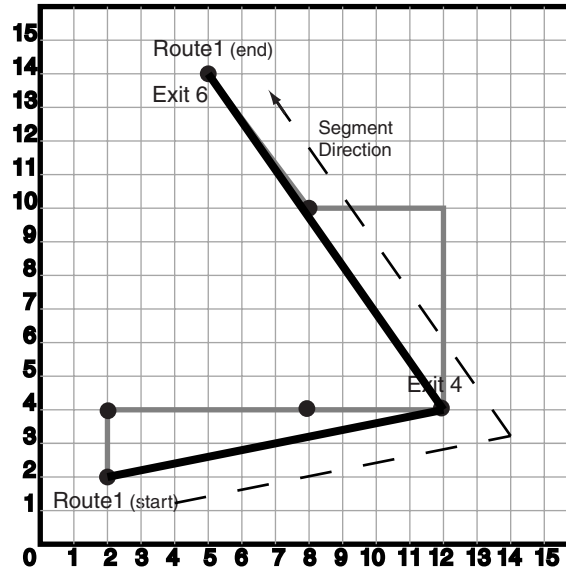

Related Topics

[SDO_UTIL.RECTIFY_GEOMETRY](#)

SDO_UTIL.TO_GML311GEOMETRY

Format

```
SDO_UTIL.TO_GML311GEOMETRY(  
    thegeom IN SDO_GEOMETRY  
    ) RETURN CLOB;
```

Description

Converts a Spatial geometry object to a geography markup language (GML version 3.1.1) fragment based on the geometry types defined in the Open GIS `geometry.xsd` schema document.

Parameters

thegeom

Geometry for which to return the GML version 3.1.1 fragment.

Usage Notes

This function does not convert circles, geometries containing any circular arcs, LRS geometries, or geometries with an SDO_ETYPE value of 0 (type 0 elements); it returns an empty CLOB in these cases.

This function converts the input geometry to a GML version 3.1.1 fragment based on some GML geometry types defined in the Open GIS Implementation Specification.

Polygons must be defined using the conventions for Oracle9i and later releases of Spatial. That is, the outer boundary is stored first (with ETYPE=1003) followed by zero or more inner boundary elements (ETYPE=2003). For a polygon with holes, the outer boundary must be stored first in the SDO_ORDINATES definition, followed by coordinates of the inner boundaries.

LRS geometries must be converted to standard geometries (using the [SDO_LRS.CONVERT_TO_STD_GEOM](#) or [SDO_LRS.CONVERT_TO_STD_LAYER](#) function) before being passed to the TO_GMLGEOMETRY function. (See the Examples section for an example that uses CONVERT_TO_STD_GEOM with the TO_GMLGEOMETRY function.)

Any circular arcs or circles must be densified (using the [SDO_GEOM.SDO_ARC_DENSIFY](#) function) or represented as polygons (using the [SDO_GEOM.SDO_BUFFER](#) function) before being passed to the TO_GMLGEOMETRY function. (See the Examples section for an example that uses SDO_ARC_DENSIFY with the TO_GMLGEOMETRY function.)

Label points are discarded. That is, if a geometry has a value for the SDO_POINT field and values in SDO_ELEM_INFO and SDO_ORDINATES, the SDO_POINT is not output in the GML fragment.

The SDO_SRID value is output in the form `srsName="SDO:<srid>"`. For example, `"SDO:8307"` indicates SDO_SRID 8307, and `"SDO:"` indicates a null SDO_SRID value. No checks are made for the validity or consistency of the SDO_SRID value. For example, the value is not checked to see if it exists in the MDSYS.CS_SRS table or if it conflicts with the SRID value for the layer in the USER_SDO_GEOM_METADATA view.

Coordinates are always output using the `<coordinates>` tag and `decimal='.'`, `cs=','` (that is, with the comma as the coordinate separator), and `ts=' '` (that is, with a space as the tuple separator), even if the `NLS_NUMERIC_CHARACTERS` setting has `','` (comma) as the decimal character.

The GML output is not formatted; there are no line breaks or indentation of tags. To see the contents of the returned CLOB in SQL*Plus, use the `TO_CHAR()` function or set the SQL*Plus parameter `LONG` to a suitable value (for example, `SET LONG 40000`). To get formatted GML output or to use the return value of `TO_GML311GEOMETRY` in SQLX or Oracle XML DB functions such as `XMLELEMENT`, use the `XMLTYPE(clobval CLOB)` constructor.

Examples

The following example returns the GML version 3.1.1 fragment for the `cola_b` geometry in the `COLA_MARKETS` table. (The example uses the definitions and data from [Section 2.1](#).)

```
-- Convert cola_b geometry to GML 3.1.1 fragment.
SELECT TO_CHAR(SDO_UTIL.TO_GML311GEOMETRY(shape)) AS Gml311Geometry
       FROM COLA_MARKETS c WHERE c.name = 'cola_b';

GML311GEOMETRY
-----
<gml:Polygon srsName="SDO:" xmlns:gml="http://www.opengis.net/gml"><gml:exterior
><gml:LinearRing><gml:posList srsDimension="2">5.0 1.0 8.0 1.0 8.0 6.0 5.0 7.0 5
.0 1.0 </gml:posList></gml:LinearRing></gml:exterior></gml:Polygon>
```

The following example returns the GML version 3.1.1 fragment for the arc densification of the `cola_d` geometry in the `COLA_MARKETS` table. (The example uses the definitions and data from [Section 2.1](#).)

```
SET LONG 40000
SELECT XMLTYPE(SDO_UTIL.TO_GML311GEOMETRY(
SDO_GEOM.SDO_ARC_DENSIFY(c.shape, m.diminfo, 'arc_tolerance=0.05')))
       AS Gml311Geometry FROM cola_markets c, user_sdo_geom_metadata m
       WHERE m.table_name = 'COLA_MARKETS' AND m.column_name = 'SHAPE'
       AND c.name = 'cola_d';

GML311GEOMETRY
-----
<gml:Polygon srsName="SDO:" xmlns:gml="http://www.opengis.net/gml">
  <gml:exterior>
    <gml:LinearRing>
      <gml:posList srsDimension="2">8.0 7.0 8.76536686473018 7.15224093497743 9.
4142135623731 7.58578643762691 9.84775906502257 8.23463313526982 10.0 9.0 9.8477
5906502257 9.76536686473018 9.4142135623731 10.4142135623731 8.76536686473018 10
.8477590650226 8.0 11.0 7.23463313526982 10.8477590650226 6.58578643762691 10.41
42135623731 6.15224093497743 9.76536686473018 6.0 9.0 6.15224093497743 8.2346331
3526982 6.58578643762691 7.5857864376269 7.23463313526982 7.15224093497743 8.0 7
.0 </gml:posList>
    </gml:LinearRing>
  </gml:exterior>
</gml:Polygon>
```

The following example converts an LRS geometry to a standard geometry and returns the GML version 3.1.1 fragment for the geometry. (The example uses the definitions and data from [Section 7.7](#).)

```
SET LONG 40000
-- Convert LRS geometry to standard geometry before using TO_GML311GEOMETRY.
```

```

SELECT XMLTYPE(SDO_UTIL.TO_GML311GEOMETRY(
  SDO_LRS.CONVERT_TO_STD_GEOM(route_geometry)))
  AS Gml311Geometry FROM lrs_routes a WHERE a.route_id = 1;

```

```
GML311GEOMETRY
```

```

-----
<gml:Curve srsName="SDO:" xmlns:gml="http://www.opengis.net/gml">
  <gml:segments>
    <gml:LineStringSegment>
      <gml:posList srsDimension="2">2.0 2.0 2.0 4.0 8.0 4.0 12.0 4.0 12.0 10.0 8
.0 10.0 5.0 14.0 </gml:posList>
    </gml:LineStringSegment>
  </gml:segments>
</gml:Curve>

```

The following examples return GML version 3.1.1 fragments for a variety of geometry types.

```

-- Point geometry with coordinates in SDO_ORDINATES. Note the
--   coordinates in the GML are (10.0 10.0) and the values in the
--   SDO_POINT field are discarded.

```

```

SELECT TO_CHAR(
  SDO_UTIL.TO_GML311GEOMETRY(sdo_geometry(2001, 8307,
    sdo_point_type(-80, 70, null),
    sdo_elem_info_array(1,1,1), sdo_ordinate_array(10, 10)))
)
AS Gml311Geometry FROM DUAL;

```

```
GML311GEOMETRY
```

```

-----
<gml:Point srsName="SDO:8307" xmlns:gml="http://www.opengis.net/gml"><gml:posList
srsDimension="2">10.0 10.0 </gml:posList></gml:Point>

```

```
-- Multipolygon
```

```

SET LONG 40000
SELECT SDO_UTIL.TO_GML311GEOMETRY(
  sdo_geometry(2007, 8307, null,
    sdo_elem_info_array(1,1003,1, 13,1003,1, 23,1003,3),
    sdo_ordinate_array(10.10,10.20, 20.50,20.10, 30.30,30.30, 40.10,40.10,
      30.50, 30.20, 10.10, 10.20,
      5,5, 5,6, 6,6, 6,5, 5,5, 7,7, 8,8 ))
)
AS Gml311Geometry FROM DUAL;

```

```
GML311GEOMETRY
```

```

-----
<gml:MultiSurface srsName="SDO:8307" xmlns:gml="http://www.opengis.net/gml"><gml
:surfaceMember><gml:Polygon><gml:exterior><gml:LinearRing><gml:posList srsDimens
ion="2">10.1 10.2 20.5 20.1 30.3 30.3 40.1 40.1 30.5 30.2 10.1 10.2 </gml:posList
t></gml:LinearRing></gml:exterior></gml:Polygon></gml:surfaceMember><gml:surface
Member><gml:Polygon><gml:exterior><gml:LinearRing><gml:posList srsDimension="2">
5.0 5.0 5.0 6.0 6.0 6.0 6.0 5.0 5.0 5.0 </gml:posList></gml:LinearRing></gml:ext
erior></gml:Polygon></gml:surfaceMember><gml:surfaceMember><gml:Polygon><gml:ext
erior><gml:LinearRing><gml:posList srsDimension="2">7.0 7.0 8.0 7.0 8.0 8.0 7.0
8.0 7.0 7.0 </gml:posList></gml:LinearRing></gml:exterior></gml:Polygon></gml:su
rfaceMember></gml:MultiSurface>

```

```

SET LONG 80
-- Rectangle (geodetic)
SELECT TO_CHAR(

```



```

SDO_UTIL.TO_GML311GEOMETRY(sdo_geometry(2003, 8307, null,
sdo_elem_info_array(1,1003,3),
sdo_ordinate_array(10.10,10.10, 20.10,20.10 )))
)
AS Gml311Geometry FROM DUAL;

GML311GEOMETRY
-----
<gml:Polygon srsName="SDO:8307" xmlns:gml="http://www.opengis.net/gml"><gml:exterior><gml:LinearRing><gml:posList srsDimension="2">10.1 10.1 20.1 10.1 20.1 20.1 10.1 20.1 10.1 10.1 </gml:posList></gml:LinearRing></gml:exterior></gml:Polygon>
>

-- Polygon with holes
SELECT TO_CHAR(
SDO_UTIL.TO_GML311GEOMETRY(sdo_geometry(2003, 262152, null,
sdo_elem_info_array(1,1003,3, 5, 2003, 1, 13, 2003, 1),
sdo_ordinate_array(10.10,10.20, 40.50, 41.10, 30.30, 30.30, 30.30,
40.10, 40.10, 40.10, 30.30, 30.30, 5, 5, 5, 6, 6, 6, 6, 5, 5, 5 )))
)
AS Gml311Geometry FROM DUAL;

GML311GEOMETRY
-----
<gml:Polygon srsName="SDO:262152" xmlns:gml="http://www.opengis.net/gml"><gml:exterior><gml:LinearRing><gml:posList srsDimension="2">10.1 10.2 40.5 10.2 40.5 41.1 10.1 41.1 10.1 10.2 </gml:posList></gml:LinearRing></gml:exterior><gml:interior><gml:LinearRing><gml:posList srsDimension="2">30.3 30.3 30.3 40.1 40.1 40.1 30.3 30.3 </gml:posList></gml:LinearRing></gml:interior><gml:interior><gml:LinearRing><gml:posList srsDimension="2">5.0 5.0 5.0 6.0 6.0 6.0 6.0 5.0 5.0 5.0 </gml:posList></gml:LinearRing></gml:interior></gml:Polygon>

-- Creating an XMLTYPE from the GML fragment. Also useful for "pretty
-- printing" the GML output.
SET LONG 40000
SELECT XMLTYPE(
SDO_UTIL.TO_GML311GEOMETRY(sdo_geometry(2003, 262152, null,
sdo_elem_info_array(1,1003,1, 11, 2003, 1, 21, 2003, 1),
sdo_ordinate_array(10.10,10.20, 40.50,10.2, 40.5,41.10, 10.1,41.1,
10.10, 10.20, 30.30,30.30, 30.30, 40.10, 40.10, 40.10, 40.10, 30.30,
30.30, 30.30, 5, 5, 5, 6, 6, 6, 6, 5, 5, 5 )))
)
AS Gml311Geometry FROM DUAL;

GML311GEOMETRY
-----
<gml:Polygon srsName="SDO:262152" xmlns:gml="http://www.opengis.net/gml">
<gml:exterior>
<gml:LinearRing>
<gml:posList srsDimension="2">10.1 10.2 40.5 10.2 40.5 41.1 10.1 41.1 10.1
10.2 </gml:posList>
</gml:LinearRing>
</gml:exterior>
<gml:interior>
<gml:LinearRing>
<gml:posList srsDimension="2">30.3 30.3 30.3 40.1 40.1 40.1 40.1 30.3 30.3
30.3 </gml:posList>

```

```
-----  
    </gml:LinearRing>  
  </gml:interior>  
<gml:interior>  
  <gml:LinearRing>  
    <gml:posList srsDimension="2">5.0 5.0 5.0 6.0 6.0 6.0 6.0 5.0 5.0 5.0 </gm  
l:posList>  
  </gml:LinearRing>  
</gml:interior>  
</gml:Polygon>
```

Related Topics

[SDO_UTIL.TO_GMLGEOMETRY](#)

SDO_UTIL.TO_GMLGEOMETRY

Format

```
SDO_UTIL.TO_GMLGEOMETRY(  
    thegeom IN SDO_GEOMETRY  
    ) RETURN CLOB;
```

Description

Converts a Spatial geometry object to a geography markup language (GML 2.0) fragment based on the geometry types defined in the Open GIS `geometry.xsd` schema document.

Parameters

thegeom

Geometry for which to return the GML fragment.

Usage Notes

This function does not convert circles, geometries containing any circular arcs, LRS geometries, or geometries with an SDO_ETYPE value of 0 (type 0 elements); it returns an empty CLOB in these cases.

This function converts the input geometry to a GML fragment based on some GML geometry types defined in the Open GIS Implementation Specification.

Polygons must be defined using the conventions for Oracle9i and later releases of Spatial. That is, the outer boundary is stored first (with ETYPE=1003) followed by zero or more inner boundary elements (ETYPE=2003). For a polygon with holes, the outer boundary must be stored first in the SDO_ORDINATES definition, followed by coordinates of the inner boundaries.

LRS geometries must be converted to standard geometries (using the [SDO_LRS.CONVERT_TO_STD_GEOM](#) or [SDO_LRS.CONVERT_TO_STD_LAYER](#) function) before being passed to the TO_GMLGEOMETRY function. (See the Examples section for an example that uses CONVERT_TO_STD_GEOM with the TO_GMLGEOMETRY function.)

Any circular arcs or circles must be densified (using the [SDO_GEOM.SDO_ARC_DENSIFY](#) function) or represented as polygons (using the [SDO_GEOM.SDO_BUFFER](#) function) before being passed to the TO_GMLGEOMETRY function. (See the Examples section for an example that uses SDO_ARC_DENSIFY with the TO_GMLGEOMETRY function.)

Label points are discarded. That is, if a geometry has a value for the SDO_POINT field and values in SDO_ELEM_INFO and SDO_ORDINATES, the SDO_POINT is not output in the GML fragment.

The SDO_SRID value is output in the form `srsName="SDO:<srid>"`. For example, `"SDO:8307"` indicates SDO_SRID 8307, and `"SDO:"` indicates a null SDO_SRID value. No checks are made for the validity or consistency of the SDO_SRID value. For example, the value is not checked to see if it exists in the MDSYS.CS_SRS table or if it conflicts with the SRID value for the layer in the USER_SDO_GEOM_METADATA view.

Coordinates are always output using the `<coordinates>` tag and `decimal='.','`, `cs=' , '` (that is, with the comma as the coordinate separator), and `ts=' '` (that is, with a space as the tuple separator), even if the `NLS_NUMERIC_CHARACTERS` setting has `' , '` (comma) as the decimal character.

The GML output is not formatted; there are no line breaks or indentation of tags. To see the contents of the returned CLOB in SQL*Plus, use the `TO_CHAR()` function or set the SQL*Plus parameter `LONG` to a suitable value (for example, `SET LONG 40000`). To get formatted GML output or to use the return value of `TO_GMLGEOMETRY` in SQLX or Oracle XML DB functions such as `XMLELEMENT`, use the `XMLTYPE(clobval CLOB)` constructor.

Examples

The following example returns the GML fragment for the `cola_b` geometry in the `COLA_MARKETS` table. (The example uses the definitions and data from [Section 2.1](#).)

```
-- Convert cola_b geometry to GML fragment.
SELECT TO_CHAR(SDO_UTIL.TO_GMLGEOMETRY(shape)) AS GmlGeometry
  FROM COLA_MARKETS c WHERE c.name = 'cola_b';

GMLGEOMETRY
-----
<gml:Polygon srsName="SDO:" xmlns:gml="http://www.opengis.net/gml"><gml:outerBoundaryIs><gml:LinearRing><gml:coordinates decimal="." cs="," ts=" ">5,1 8,1 8,6 5
,7 5,1 </gml:coordinates></gml:LinearRing></gml:outerBoundaryIs></gml:Polygon>
```

The following example returns the GML fragment for the arc densification of the `cola_d` geometry in the `COLA_MARKETS` table. (The example uses the definitions and data from [Section 2.1](#).)

```
SET LONG 40000
SELECT XMLTYPE(SDO_UTIL.TO_GMLGEOMETRY(
  SDO_GEOM.SDO_ARC_DENSIFY(c.shape, m.diminfo, 'arc_tolerance=0.05')))
  AS GmlGeometry FROM cola_markets c, user_sdo_geom_metadata m
  WHERE m.table_name = 'COLA_MARKETS' AND m.column_name = 'SHAPE'
  AND c.name = 'cola_d';

GMLGEOMETRY
-----
<gml:Polygon srsName="SDO:" xmlns:gml="http://www.opengis.net/gml"><gml:outerBoundaryIs><gml:LinearRing><gml:coordinates decimal="." cs="," ts=" ">8,7 8.7653668
6473018,7.15224093497743 9.4142135623731,7.58578643762691 9.84775906502257,8.234
63313526982 10,9 9.84775906502257,9.76536686473018 9.4142135623731,10.4142135623
731 8.76536686473018,10.8477590650226 8,11 7.23463313526982,10.8477590650226 6.5
8578643762691,10.4142135623731 6.15224093497743,9.76536686473018 6,9 6.152240934
97743,8.23463313526982 6.58578643762691,7.5857864376269 7.23463313526982,7.15224
093497743 8,7 </gml:coordinates></gml:LinearRing></gml:outerBoundaryIs></gml:Pol
ygon>
```

The following example converts an LRS geometry to a standard geometry and returns the GML fragment for the geometry. (The example uses the definitions and data from [Section 7.7](#).)

```
SET LONG 40000
-- Convert LRS geometry to standard geometry before using TO_GMLGEOMETRY.
SELECT XMLTYPE(SDO_UTIL.TO_GMLGEOMETRY(
  SDO_LRS.CONVERT_TO_STD_GEOM(route_geometry)))
  AS GmlGeometry FROM lrs_routes a WHERE a.route_id = 1;

GMLGEOMETRY
```

```
-----
<gml:LineString srsName="SDO:" xmlns:gml="http://www.opengis.net/gml">
  <gml:coordinates decimal="." cs="," ts=" ">2,2 2,4 8,4 12,4 12,10 8,10 5,14 </
gml:coordinates>
</gml:LineString>
```

The following examples return GML fragments for a variety of geometry types.

```
-- Point geometry with coordinates in SDO_ORDINATES. Note the
-- coordinates in the GML are (10,10) and the values in the
-- SDO_POINT field are discarded.
```

```
SELECT TO_CHAR(
  SDO_UTIL.TO_GMLGEOMETRY(sdo_geometry(2001, 8307,
    sdo_point_type(-80, 70, null),
    sdo_elem_info_array(1,1,1), sdo_ordinate_array(10, 10)))
)
AS GmlGeometry FROM DUAL;
```

GMLGEOMETRY

```
-----
<gml:Point srsName="SDO:8307" xmlns:gml="http://www.opengis.net/gml"><gml:coordi
nates decimal="." cs="," ts=" ">10,10 </gml:coordinates></gml:Point>
```

```
-- Multipolygon
```

```
SET LONG 40000
SELECT SDO_UTIL.TO_GMLGEOMETRY(
  sdo_geometry(2007, 8307, null,
    sdo_elem_info_array(1,1003,1, 13,1003,1, 23,1003,3),
    sdo_ordinate_array(10.10,10.20, 20.50,20.10, 30.30,30.30, 40.10,40.10,
      30.50, 30.20, 10.10, 10.20,
      5,5, 5,6, 6,6, 6,5, 5,5, 7,7, 8,8 ))
)
AS GmlGeometry FROM DUAL;
```

GMLGEOMETRY

```
-----
<gml:MultiPolygon srsName="SDO:8307" xmlns:gml="http://www.opengis.net/gml"><gml
:polygonMember><gml:Polygon><gml:outerBoundaryIs><gml:LinearRing><gml:coordinate
s decimal="." cs="," ts=" ">10.1,10.2 20.5,20.1 30.3,30.3 40.1,40.1 30.5,30.2 10
.1,10.2 </gml:coordinates></gml:LinearRing></gml:outerBoundaryIs></gml:Polygon><
/gml:polygonMember><gml:polygonMember><gml:Polygon><gml:outerBoundaryIs><gml:Lin
earRing><gml:coordinates decimal="." cs="," ts=" ">5.0,5.0 5.0,6.0 6.0,6.0 6.0,5
.0 5.0,5.0 </gml:coordinates></gml:LinearRing></gml:outerBoundaryIs></gml:Polygo
n></gml:polygonMember><gml:polygonMember><gml:Polygon><gml:outerBoundaryIs><gml:
LinearRing><gml:coordinates decimal="." cs="," ts=" ">7.0,7.0 8.0,7.0 8.0,8.0 7.
0,8.0 7.0,7.0 </gml:coordinates></gml:LinearRing></gml:outerBoundaryIs></gml:Pol
ygon></gml:polygonMember></gml:MultiPolygon>
```

```
SQL> SET LONG 80
```

```
-- Rectangle (geodetic)
```

```
SELECT TO_CHAR(
  SDO_UTIL.TO_GMLGEOMETRY(sdo_geometry(2003, 8307, null,
    sdo_elem_info_array(1,1003,3),
    sdo_ordinate_array(10.10,10.10, 20.10,20.10 )))
)
AS GmlGeometry FROM DUAL;
```

GMLGEOMETRY

```
<gml:Box srsName="SDO:8307" xmlns:gml="http://www.opengis.net/gml"><gml:coordinates decimal="." cs="," ts=" ">10.1,10.1 20.1,20.1 </gml:coordinates></gml:Box>
```

```
-- Polygon with holes
```

```
SELECT TO_CHAR(
  SDO_UTIL.TO_GMLGEOMETRY(sdo_geometry(2003, 262152, null,
    sdo_elem_info_array(1,1003,3, 5, 2003, 1, 13, 2003, 1),
    sdo_ordinate_array(10.10,10.20, 40.50, 41.10, 30.30, 30.30, 30.30,
      40.10, 40.10, 40.10, 30.30, 30.30, 5, 5, 5, 6, 6, 6, 6, 5, 5, 5 )))
)
AS GmlGeometry FROM DUAL;
```

```
GMLGEOMETRY
```

```
-----
<gml:Polygon srsName="SDO:262152" xmlns:gml="http://www.opengis.net/gml"><gml:outerBoundaryIs><gml:LinearRing><gml:coordinates decimal="." cs="," ts=" ">10.1,10.2, 40.5,10.2, 40.5,41.1, 10.1,41.1, 10.1,10.2 </gml:coordinates></gml:LinearRing></gml:outerBoundaryIs><gml:innerBoundaryIs><gml:LinearRing><gml:coordinates decimal="." cs="," ts=" ">30.3,30.3 30.3,40.1 40.1,40.1 30.3,30.3 </gml:coordinates></gml:LinearRing></gml:innerBoundaryIs><gml:innerBoundaryIs><gml:LinearRing><gml:coordinates decimal="." cs="," ts=" ">5,5 5,6 6,6 6,5 5,5 </gml:coordinates></gml:LinearRing></gml:innerBoundaryIs></gml:Polygon>
```

```
-- Creating an XMLTYPE from the GML fragment. Also useful for "pretty
-- printing" the GML output.
```

```
SET LONG 40000
SELECT XMLTYPE(
  SDO_UTIL.TO_GMLGEOMETRY(sdo_geometry(2003, 262152, null,
    sdo_elem_info_array(1,1003,1, 11, 2003, 1, 21, 2003, 1),
    sdo_ordinate_array(10.10,10.20, 40.50,10.2, 40.5,41.10, 10.1,41.1,
      10.10, 10.20, 30.30,30.30, 30.30, 40.10, 40.10, 40.10, 40.10, 30.30,
      30.30, 30.30, 5, 5, 5, 6, 6, 6, 6, 5, 5, 5 )))
)
AS GmlGeometry FROM DUAL;
```

```
GMLGEOMETRY
```

```
-----
<gml:Polygon srsName="SDO:262152" xmlns:gml="http://www.opengis.net/gml"><gml:outerBoundaryIs><gml:LinearRing><gml:coordinates decimal="." cs="," ts=" ">10.1,10.2 40.5,10.2 40.5,41.1 10.1,41.1 10.1,10.2 </gml:coordinates></gml:LinearRing></gml:outerBoundaryIs><gml:innerBoundaryIs><gml:LinearRing><gml:coordinates decimal="." cs="," ts=" ">30.3,30.3 30.3,40.1 40.1,40.1 40.1,30.3 30.3,30.3 </gml:coordinates></gml:LinearRing></gml:innerBoundaryIs><gml:innerBoundaryIs><gml:LinearRing><gml:coordinates decimal="." cs="," ts=" ">5,5 5,6 6,6 6,5 5,5 </gml:coordinates></gml:LinearRing></gml:innerBoundaryIs></gml:Polygon>
```

The following example uses the TO_GMLGEOMETRY function with the Oracle XML DB XMLTYPE data type and the XMLELEMENT and XMLFOREST functions.

```
SELECT xmlelement("State", xmlattributes(
  'http://www.opengis.net/gml' as "xmlns:gml"),
  xmlforest(state as "Name", totpop as "Population",
  xmltype(sdo_util.to_gmlgeometry(geom)) as "gml:geometryProperty"))
AS theXMLElements FROM states WHERE state_abrv in ('DE', 'UT');
```

```
THEXMLELEMENTS
```

```
-----
<State xmlns:gml="http://www.opengis.net/gml">
  <Name>Delaware</Name>
```

```
<Population>666168</Population>
<gml:geometryProperty>
  <gml:Polygon srsName="SDO:" xmlns:gml="http://www.opengis.net/gml">
    <gml:outerBoundaryIs>
      <gml:LinearRing>
        <gml:coordinates decimal="." cs="," ts=" ">-75.788704,39.721699 -75.78
8704,39.6479 -75.767014,39.377106 -75.76033,39.296497 -75.756294,39.24585 -75.74
8016,39.143196 -75.722961,38.829895 -75.707695,38.635166 -75.701912,38.560619 -7
5.693871,38.460011 -75.500336,38.454002 -75.341614,38.451855 -75.049339,38.45165
3 -75.053841,38.538429 -75.06015,38.605465 -75.063263,38.611275 -75.065308,38.62
949 -75.065887,38.660919 -75.078697,38.732403 -75.082527,38.772045 -75.091667,38
.801208 -75.094185,38.803699 -75.097572,38.802986 -75.094116,38.793579 -75.09926
6,38.78756 -75.123619,38.781784 -75.137962,38.782703 -75.18692,38.803772 -75.215
019,38.831547 -75.23735,38.849014 -75.260498,38.875 -75.305908,38.914673 -75.316
399,38.930309 -75.317284,38.93676 -75.312851,38.945576 -75.312859,38.945618 -75.
31205,38.967804 -75.31778,38.986012 -75.341431,39.021233 -75.369606,39.041359 -7
5.389229,39.051422 -75.40181,39.06702 -75.401306,39.097713 -75.411369,39.148029
-75.407845,39.175201 -75.396271,39.187778 -75.39225,39.203377 -75.40181,39.23104
9 -75.402817,39.253189 -75.409355,39.264759 -75.434006,39.290424 -75.439041,39.3
13065 -75.453125,39.317093 -75.457657,39.326653 -75.469231,39.330677 -75.486336,
39.341743 -75.494888,39.354324 -75.504448,39.357346 -75.51284,39.366291 -75.5129
24,39.366482 -75.523773,39.392052 -75.538651,39.415707 -75.56749,39.436436 -75.5
9137,39.463696 -75.592941,39.471806 -75.590019,39.488026 -75.587311,39.496136 -7
5.5774,39.508076 -75.554192,39.506947 -75.528442,39.498005 -75.530373,39.510303
-75.527145,39.531326 -75.52803,39.535168 -75.53437,39.540592 -75.519386,39.55528
6 -75.512291,39.567505 -75.515587,39.580639 -75.528046,39.584 -75.538269,39.5935
67 -75.554016,39.601727 -75.560143,39.622578 -75.556602,39.6348 -75.549599,39.63
7699 -75.542397,39.645901 -75.535507,39.647099 -75.514999,39.668499 -75.507523,3
9.69685 -75.496597,39.701302 -75.488914,39.714722 -75.477997,39.714901 -75.47550
2,39.733501 -75.467972,39.746975 -75.463707,39.761101 -75.448494,39.773857 -75.4
38301,39.783298 -75.405701,39.796101 -75.415405,39.801678 -75.454102,39.820202 -
75.499199,39.833199 -75.539703,39.8381 -75.5802,39.838417 -75.594017,39.837345 -
75.596107,39.837044 -75.639488,39.82893 -75.680145,39.813839 -75.71096,39.796352
-75.739716,39.772881 -75.760689,39.74712 -75.774101,39.721699 -75.788704,39.721
699 </gml:coordinates>
      </gml:LinearRing>
    </gml:outerBoundaryIs>
  </gml:Polygon>
</gml:geometryProperty>
</State>

<State xmlns:gml="http://www.opengis.net/gml">
  <Name>Utah</Name>
  <Population>1722850</Population>
  <gml:geometryProperty>
    <gml:Polygon srsName="SDO:" xmlns:gml="http://www.opengis.net/gml">
      <gml:outerBoundaryIs>
        <gml:LinearRing>
          <gml:coordinates decimal="." cs="," ts=" ">-114.040871,41.993805 -114.
038803,41.884899 -114.041306,41 -114.04586,40.116997 -114.046295,39.906101 -114.
046898,39.542801 -114.049026,38.67741 -114.049339,38.572968 -114.049095,38.14864
-114.0476,37.80946 -114.05098,37.746284 -114.051666,37.604805 -114.052025,37.10
3989 -114.049797,37.000423 -113.484375,37 -112.898598,37.000401 -112.539604,37.0
00683 -112,37.000977 -111.412048,37.001514 -111.133018,37.00079 -110.75,37.00320
1 -110.5,37.004265 -110.469505,36.998001 -110,36.997967 -109.044571,36.999088 -1
09.045143,37.375 -109.042824,37.484692 -109.040848,37.881176 -109.041405,38.1530
27 -109.041107,38.1647 -109.059402,38.275501 -109.059296,38.5 -109.058868,38.719
906 -109.051765,39 -109.050095,39.366699 -109.050697,39.4977 -109.050499,39.6605
-109.050156,40.222694 -109.047577,40.653641 -109.0494,41.000702 -109.2313,41.00
2102 -109.534233,40.998184 -110,40.997398 -110.047768,40.997696 -110.5,40.994801
```

```
-111.045982,40.998013 -111.045815,41.251774 -111.045097,41.579899 -111.045944,4
2.001633 -111.506493,41.999588 -112.108742,41.997677 -112.16317,41.996784 -112.1
72562,41.996643 -112.192184,42.001244 -113,41.998314 -113.875,41.988091 -114.040
871,41.993805 </gml:coordinates>
  </gml:LinearRing>
</gml:outerBoundaryIs>
</gml:Polygon>
</gml:geometryProperty>
</State>
```

Related Topics

[SDO_UTIL.TO_GML311GEOMETRY](#)

SDO_UTIL.TO_KMLGEOMETRY

Format

```
SDO_UTIL.TO_KMLGEOMETRY(  
    geometry IN SDO_GEOMETRY  
    ) RETURN CLOB;
```

Description

Converts a Spatial geometry object to a KML (Keyhole Markup Language) document.

Parameters

geometry

Geometry for which to return the KML document.

Usage Notes

This function does not convert circles, geometries containing any circular arcs, LRS geometries, or geometries with an SDO_ETYPE value of 0 (type 0 elements); it returns an empty CLOB in these cases.

Polygons must be defined using the conventions for Oracle9i and later releases of Spatial. That is, the outer boundary is stored first (with ETYPE=1003) followed by zero or more inner boundary elements (ETYPE=2003). For a polygon with holes, the outer boundary must be stored first in the SDO_ORDINATES definition, followed by coordinates of the inner boundaries.

LRS geometries must be converted to standard geometries (using the [SDO_LRS.CONVERT_TO_STD_GEOM](#) or [SDO_LRS.CONVERT_TO_STD_LAYER](#) function) before being passed to the TO_KMLGEOMETRY function.

Any circular arcs or circles must be densified (using the [SDO_GEOM.SDO_ARC_DENSIFY](#) function) or represented as polygons (using the [SDO_GEOM.SDO_BUFFER](#) function) before being passed to the TO_KMLGEOMETRY function.

Label points are discarded. That is, if a geometry has a value for the SDO_POINT field and values in SDO_ELEM_INFO and SDO_ORDINATES, the SDO_POINT is not output in the KML document.

Solid geometries are converted to KML MultiGeometry objects, because KML 2.1 does not support solids. If you then use the [SDO_UTIL.FROM_KMLGEOMETRY](#) function on the MultiGeometry, the result is not an Oracle Spatial solid geometry (that is, its SDO_GTYPE value does not reflect a geometry type of SOLID or MULTISOLID).

The KML output is not formatted; there are no line breaks or indentation of tags. To see the contents of the returned CLOB in SQL*Plus, use the TO_CHAR() function or set the SQL*Plus parameter LONG to a suitable value (for example, SET LONG 2000). To get formatted GML output or to use the return value of TO_KMLGEOMETRY in SQLX or Oracle XML DB functions such as XMLELEMENT, use the XMLTYPE(clobval CLOB) constructor.

Examples

The following example shows conversion to and from KML format. (The example uses the definitions and data from [Section 2.1](#), specifically the `cola_c` geometry from the `COLA_MARKETS` table.)

```
-- Convert cola_c geometry to a KML document; convert that result to
-- a spatial geometry.
set long 2000;
DECLARE
  kmlgeom CLOB;
  val_result VARCHAR2(5);
  geom_result SDO_GEOMETRY;
  geom SDO_GEOMETRY;
BEGIN
  SELECT c.shape INTO geom FROM cola_markets c WHERE c.name = 'cola_c';

  -- To KML geometry
  kmlgeom := SDO_UTIL.TO_KMLGEOMETRY(geom);
  DBMS_OUTPUT.PUT_LINE('To KML geometry result = ' || TO_CHAR(kmlgeom));

  -- From KML geometry
  geom_result := SDO_UTIL.FROM_KMLGEOMETRY(kmlgeom);
  -- Validate the returned geometry.
  val_result := SDO_GEOM.VALIDATE_GEOMETRY_WITH_CONTEXT(geom_result, 0.005);
  DBMS_OUTPUT.PUT_LINE('Validation result = ' || val_result);

END;
/
To KML geometry result =
<Polygon><extrude>0</extrude><tessellate>0</tessellate><altitudeMode>relativeToG
round</altitudeMode><outerBoundaryIs><LinearRing><coordinates>3.0,3.0 6.0,3.0
6.0,5.0 4.0,5.0 3.0,3.0 </coordinates></LinearRing></outerBoundaryIs></Polygon>
Validation result = TRUE
```

Related Topics

- [SDO_UTIL.FROM_KMLGEOMETRY](#)

SDO_UTIL.TO_WKBGEOMETRY

Format

```
SDO_UTIL.TO_WKBGEOMETRY(
    geometry IN SDO_GEOMETRY
) RETURN BLOB;
```

Description

Converts a Spatial geometry object to the well-known binary (WKB) format.

Parameters

geometry

SDO_GEOMETRY object to be converted to WKB format.

Usage Notes

The input geometry is converted to the well-known binary (WKB) format, as defined by the Open Geospatial Consortium and the International Organization for Standardization (ISO).

This function is patterned after the SQL Multimedia recommendations in *ISO 13249-3, Information technology - Database languages - SQL Multimedia and Application Packages - Part 3: Spatial*.

To convert a geometry in WKB format to an SDO_GEOMETRY object, use the [SDO_UTIL.FROM_WKBGEOMETRY](#) function.

Examples

The following example shows conversion to and from WKB and WKT format, and validation of WKB and WKT geometries. (The example uses the definitions and data from [Section 2.1](#), specifically the `cola_b` geometry from the `COLA_MARKETS` table.)

```
DECLARE
    wkbgeom BLOB;
    wktgeom CLOB;
    val_result VARCHAR2(5);
    geom_result SDO_GEOMETRY;
    geom SDO_GEOMETRY;
BEGIN
    SELECT c.shape INTO geom FROM cola_markets c WHERE c.name = 'cola_b';

    -- To WBT/WKT geometry
    wkbgeom := SDO_UTIL.TO_WKBGEOMETRY(geom);
    wktgeom := SDO_UTIL.TO_WKTGEOMETRY(geom);
    DBMS_OUTPUT.PUT_LINE('To WKT geometry result = ' || TO_CHAR(wktgeom));

    -- From WBT/WKT geometry
    geom_result := SDO_UTIL.FROM_WKBGEOMETRY(wkbgeom);
    geom_result := SDO_UTIL.FROM_WKTGEOMETRY(wktgeom);

    -- Validate WBT/WKT geometry
    val_result := SDO_UTIL.VALIDATE_WKBGEOMETRY(wkbgeom);
    DBMS_OUTPUT.PUT_LINE('WKB validation result = ' || val_result);
```

```
val_result := SDO_UTIL.VALIDATE_WKTGEOMETRY(wktgeom);  
DBMS_OUTPUT.PUT_LINE('WKT validation result = ' || val_result);  
  
END;  
/
```

```
To WKT geometry result = POLYGON ((5.0 1.0, 8.0 1.0, 8.0 6.0, 5.0 7.0, 5.0 1.0))  
WKB validation result = TRUE  
WKT validation result = TRUE
```

Related Topics

- [SDO_UTIL.FROM_WKBGEOMETRY](#)
- [SDO_UTIL.FROM_WKTGEOMETRY](#)
- [SDO_UTIL.TO_WKTGEOMETRY](#)
- [SDO_UTIL.VALIDATE_WKBGEOMETRY](#)
- [SDO_UTIL.VALIDATE_WKTGEOMETRY](#)

SDO_UTIL.TO_WKTGEOMETRY

Format

```
SDO_UTIL.TO_WKTGEOMETRY(
    geometry IN SDO_GEOMETRY
) RETURN CLOB;
```

Description

Converts a Spatial geometry object to the well-known text (WKT) format.

Parameters

geometry

SDO_GEOMETRY object to be converted to WKT format.

Usage Notes

The input geometry is converted to the well-known text (WKT) format, as defined by the Open Geospatial Consortium and the International Organization for Standardization (ISO).

This function is patterned after the SQL Multimedia recommendations in *ISO 13249-3, Information technology - Database languages - SQL Multimedia and Application Packages - Part 3: Spatial*.

To convert a geometry in WKT format to an SDO_GEOMETRY object, use the [SDO_UTIL.FROM_WKTGEOMETRY](#) function.

Examples

The following example shows conversion to and from WKB and WKT format, and validation of WKB and WKT geometries. (The example uses the definitions and data from [Section 2.1](#), specifically the `cola_b` geometry from the `COLA_MARKETS` table.)

```
DECLARE
    wkbgeom BLOB;
    wktgeom CLOB;
    val_result VARCHAR2(5);
    geom_result SDO_GEOMETRY;
    geom SDO_GEOMETRY;
BEGIN
    SELECT c.shape INTO geom FROM cola_markets c WHERE c.name = 'cola_b';

    -- To WBT/WKT geometry
    wkbgeom := SDO_UTIL.TO_WKBGEOMETRY(geom);
    wktgeom := SDO_UTIL.TO_WKTGEOMETRY(geom);
    DBMS_OUTPUT.PUT_LINE('To WKT geometry result = ' || TO_CHAR(wktgeom));

    -- From WBT/WKT geometry
    geom_result := SDO_UTIL.FROM_WKBGEOMETRY(wkbgeom);
    geom_result := SDO_UTIL.FROM_WKTGEOMETRY(wktgeom);

    -- Validate WBT/WKT geometry
    val_result := SDO_UTIL.VALIDATE_WKBGEOMETRY(wkbgeom);
    DBMS_OUTPUT.PUT_LINE('WKB validation result = ' || val_result);
```

```
val_result := SDO_UTIL.VALIDATE_WKTGEOMETRY(wktgeom);
DBMS_OUTPUT.PUT_LINE('WKT validation result = ' || val_result);

END;
/
```

```
To WKT geometry result = POLYGON ((5.0 1.0, 8.0 1.0, 8.0 6.0, 5.0 7.0, 5.0 1.0))
WKB validation result = TRUE
WKT validation result = TRUE
```

Related Topics

- [SDO_UTIL.FROM_WKBGEOMETRY](#)
- [SDO_UTIL.FROM_WKTGEOMETRY](#)
- [SDO_UTIL.TO_WKBGEOMETRY](#)
- [SDO_UTIL.VALIDATE_WKBGEOMETRY](#)
- [SDO_UTIL.VALIDATE_WKTGEOMETRY](#)

SDO_UTIL.VALIDATE_WKBGEOMETRY

Format

```
SDO_UTIL.VALIDATE_WKBGEOMETRY(
    geometry IN BLOB
) RETURN VARCHAR2;
```

Description

Validates the input geometry, which is in the standard well-known binary (WKB) format; returns the string `TRUE` if the geometry is valid or `FALSE` if the geometry is not valid.

Parameters

geometry

Geometry in WKB format to be checked for validity.

Usage Notes

To be valid, the input geometry must be in the well-known binary (WKB) format, as defined by the Open Geospatial Consortium and the International Organization for Standardization (ISO).

This function is patterned after the SQL Multimedia recommendations in *ISO 13249-3, Information technology - Database languages - SQL Multimedia and Application Packages - Part 3: Spatial*.

To validate a geometry in the well-known text (WKT) format, use the [SDO_UTIL.VALIDATE_WKTGEOMETRY](#) function.

Examples

The following example shows conversion to and from WKB and WKT format, and validation of WKB and WKT geometries. (The example uses the definitions and data from [Section 2.1](#), specifically the `cola_b` geometry from the `COLA_MARKETS` table.)

```
DECLARE
    wkbgeom BLOB;
    wktgeom CLOB;
    val_result VARCHAR2(5);
    geom_result SDO_GEOMETRY;
    geom SDO_GEOMETRY;
BEGIN
    SELECT c.shape INTO geom FROM cola_markets c WHERE c.name = 'cola_b';

    -- To WBT/WKT geometry
    wkbgeom := SDO_UTIL.TO_WKBGEOMETRY(geom);
    wktgeom := SDO_UTIL.TO_WKTGEOMETRY(geom);
    DBMS_OUTPUT.PUT_LINE('To WKT geometry result = ' || TO_CHAR(wktgeom));

    -- From WBT/WKT geometry
    geom_result := SDO_UTIL.FROM_WKBGEOMETRY(wkbgeom);
    geom_result := SDO_UTIL.FROM_WKTGEOMETRY(wktgeom);

    -- Validate WBT/WKT geometry
```

```
val_result := SDO_UTIL.VALIDATE_WKBGEOMETRY(wkbgeom);
DBMS_OUTPUT.PUT_LINE('WKB validation result = ' || val_result);
val_result := SDO_UTIL.VALIDATE_WKTGEOMETRY(wktgeom);
DBMS_OUTPUT.PUT_LINE('WKT validation result = ' || val_result);

END;
/
```

```
To WKT geometry result = POLYGON ((5.0 1.0, 8.0 1.0, 8.0 6.0, 5.0 7.0, 5.0 1.0))
WKB validation result = TRUE
WKT validation result = TRUE
```

Related Topics

- [SDO_UTIL.FROM_WKBGEOMETRY](#)
- [SDO_UTIL.FROM_WKTGEOMETRY](#)
- [SDO_UTIL.TO_WKBGEOMETRY](#)
- [SDO_UTIL.TO_WKTGEOMETRY](#)
- [SDO_UTIL.VALIDATE_WKTGEOMETRY](#)

SDO_UTIL.VALIDATE_WKTGEOMETRY

Format

```
SDO_UTIL.VALIDATE_WKTGEOMETRY(
    geometry IN CLOB
) RETURN VARCHAR2;
```

or

```
SDO_UTIL.VALIDATE_WKTGEOMETRY(
    geometry IN VARCHAR2
) RETURN VARCHAR2;
```

Description

Validates the input geometry, which is of type CLOB or VARCHAR2 and in the standard well-known text (WKT) format; returns the string `TRUE` if the geometry is valid or `FALSE` if the geometry is not valid.

Parameters

geometry

Geometry in WKT format to be checked for validity.

Usage Notes

To be valid, the input geometry must be in the well-known text (WKT) format, as defined by the Open Geospatial Consortium and the International Organization for Standardization (ISO).

This function is patterned after the SQL Multimedia recommendations in *ISO 13249-3, Information technology - Database languages - SQL Multimedia and Application Packages - Part 3: Spatial*.

To validate a geometry in the well-known binary (WKB) format, use the [SDO_UTIL.VALIDATE_WKBGEOMETRY](#) function.

Examples

The following example shows conversion to and from WKB and WKT format, and validation of WKB and WKT geometries. (The example uses the definitions and data from [Section 2.1](#), specifically the `cola_b` geometry from the `COLA_MARKETS` table.)

```
DECLARE
    wkbgeom BLOB;
    wktgeom CLOB;
    val_result VARCHAR2(5);
    geom_result SDO_GEOMETRY;
    geom SDO_GEOMETRY;
BEGIN
    SELECT c.shape INTO geom FROM cola_markets c WHERE c.name = 'cola_b';

    -- To WBT/WKT geometry
    wkbgeom := SDO_UTIL.TO_WKBGEOMETRY(geom);
    wktgeom := SDO_UTIL.TO_WKTGEOMETRY(geom);
    DBMS_OUTPUT.PUT_LINE('To WKT geometry result = ' || TO_CHAR(wktgeom));
```

```
-- From WBT/WKT geometry
geom_result := SDO_UTIL.FROM_WKBGEOMETRY(wkbgeom);
geom_result := SDO_UTIL.FROM_WKTGEOMETRY(wktgeom);

-- Validate WBT/WKT geometry
val_result := SDO_UTIL.VALIDATE_WKBGEOMETRY(wkbgeom);
DBMS_OUTPUT.PUT_LINE('WKB validation result = ' || val_result);
val_result := SDO_UTIL.VALIDATE_WKTGEOMETRY(wktgeom);
DBMS_OUTPUT.PUT_LINE('WKT validation result = ' || val_result);

END;
/

To WKT geometry result = POLYGON ((5.0 1.0, 8.0 1.0, 8.0 6.0, 5.0 7.0, 5.0 1.0))
WKB validation result = TRUE
WKT validation result = TRUE
```

Related Topics

- [SDO_UTIL.FROM_WKBGEOMETRY](#)
- [SDO_UTIL.FROM_WKTGEOMETRY](#)
- [SDO_UTIL.TO_WKBGEOMETRY](#)
- [SDO_UTIL.TO_WKTGEOMETRY](#)
- [SDO_UTIL.VALIDATE_WKBGEOMETRY](#)

SDO_WFS_LOCK Package (WFS)

The MDSYS.SDO_WFS_LOCK package contains subprograms for WFS support for registering and unregistering feature tables. Registering a feature table enables the table for WFS transaction locking; unregistering a feature table disables the table for WFS transaction locking.

To use the subprograms in this chapter, you must understand the conceptual and usage information about Web Feature Services (WFS) in [Chapter 15](#).

[Table 33–1](#) lists the WFS support subprograms.

Table 33–1 Subprograms for WFS Support

Subprogram	Description
SDO_WFS_LOCK.EnableDBTxns	Enables database transactions on WFS tables.
SDO_WFS_LOCK.RegisterFeatureTable	Registers a feature table; that is, enables the feature table for WFS transaction locking.
SDO_WFS_LOCK.UnRegisterFeatureTable	Unregisters a feature table; that is, disables the feature table for WFS transaction locking.

The rest of this chapter provides reference information on the subprograms, listed in alphabetical order.

SDO_WFS_LOCK.EnableDBTxns

Format

```
SDO_WFS_LOCK.EnableDBTxns();
```

Description

Enables database transactions on WFS tables.

Parameters

None.

Usage Notes

This procedure overrides, through the end of the session, the WFS-T standard restriction against database transactions on WFS tables, so that any transaction with the current session ID can perform update and delete operations on WFS tables. Oracle Database triggers still check the WFS locks before the current transaction is allowed to modify a row; and so if a WFS transaction has a lock on a row, the triggers will not allow the operation to be performed. However, if there is no WFS lock on the current row, the triggers will allow the current transaction to modify the row.

You must call this procedure to perform certain operations when using Oracle Workspace Manager to version-enable a WFS table, as explained in [Section 15.5](#). However, you can also use this procedure even if you do not use Workspace Manager with WFS tables.

For information about support for Web Feature Services, see [Chapter 15](#).

Examples

The following example enables database transactions on WFS tables for the remainder of the current session.

```
BEGIN
    SDO_WFS_LOCK.enableDBTxns;
END;
/
```

SDO_WFS_LOCK.RegisterFeatureTable

Format

```
SDO_WFS_LOCK.RegisterFeatureTable(  
    username IN VARCHAR2,  
    tablename IN VARCHAR2);
```

Description

Registers a feature table; that is, enables the feature table for WFS transaction locking.

Parameters

username

Name of the database user that owns the feature table to be registered.

tablename

Name of the feature table to be registered.

Usage Notes

This procedure ensures that the necessary constraints for implementing WFS transaction semantics are associated with the feature table.

For information about support for Web Feature Services, see [Chapter 15](#).

To unregister a table that has not been version-enabled, use the [SDO_WFS_LOCK.UnRegisterFeatureTable](#) procedure.

Examples

The following example registers the feature table named COLA_MARKETS_CS, which is owned by user WFS_REL_USER.

```
BEGIN  
    SDO_WFS_LOCK.registerFeatureTable('wfs_rel_user', 'cola_markets_cs');  
END;  
/
```

SDO_WFS_LOCK.UnRegisterFeatureTable

Format

```
SDO_WFS_LOCK.UnRegisterFeatureTable(  
    username IN VARCHAR2,  
    tablename IN VARCHAR2);
```

Description

Unregisters a feature table; that is, disables the feature table for WFS transaction locking.

Parameters

username

Name of the database user that owns the feature table to be unregistered.

tablename

Name of the feature table to be unregistered.

Usage Notes

This procedure disables, for the feature table, the constraints for implementing WFS transaction semantics.

The feature table must have been previously registered in a call to the [SDO_WFS_LOCK.RegisterFeatureTable](#) procedure.

For information about support for Web Feature Services, see [Chapter 15](#).

Examples

The following example unregisters the feature table named COLA_MARKETS_CS, which is owned by user WFS_REL_USER.

```
BEGIN  
    SDO_WFS_LOCK.unRegisterFeatureTable('wfs_rel_user', 'cola_markets_cs');  
END;  
/
```

SDO_WFS_PROCESS Package (WFS Processing)

The MDSYS.SDO_WFS_PROCESS package contains subprograms for various processing operations related to support for Web Feature Services.

To use the subprograms in this chapter, you must understand the conceptual and usage information about Web Feature Services in [Chapter 15](#).

[Table 34–1](#) lists the WFS processing subprograms.

Table 34–1 Subprograms for WFS Processing Operations

Subprogram	Description
SDO_WFS_PROCESS.DropFeatureType	Deletes a specified feature type.
SDO_WFS_PROCESS.DropFeatureTypes	Deletes all feature types in a specified namespace.
SDO_WFS_PROCESS.GenCollectionProcs	Generates helper procedures for relational feature types that have collection-based columns (for example, VARRAYs or nested tables).
SDO_WFS_PROCESS.GetFeatureTypeId	Gets the feature type ID of a specified feature type.
SDO_WFS_PROCESS.GrantFeatureTypeToUser	Grants access to a feature type to a database user.
SDO_WFS_PROCESS.GrantMDAccessToUser	Grants access to WFS metadata tables to a database user.
SDO_WFS_PROCESS.InsertCapabilitiesInfo	Inserts the capabilities template information.
SDO_WFS_PROCESS.InsertFtDataUpdated	Inserts a notification that the data for one or more feature instances was updated in the database.
SDO_WFS_PROCESS.InsertFtMDUpdated	Inserts a notification that the metadata for a feature type was updated in the database.
SDO_WFS_PROCESS.PopulateFeatureTypeXMLInfo	Populates metadata for relational feature types that have XMLType columns.
SDO_WFS_PROCESS.PublishFeatureType	Publishes a feature type; that is, registers metadata related to the feature type.
SDO_WFS_PROCESS.RegisterMTableView	Enables the publishing of content from a multitable view as a feature instance.
SDO_WFS_PROCESS.RevokeFeatureTypeFromUser	Revokes access to a feature type from a database user.
SDO_WFS_PROCESS.RevokeMDAccessFromUser	Revokes access to WFS metadata tables from a database user.

Table 34–1 (Cont.) Subprograms for WFS Processing Operations

Subprogram	Description
SDO_WFS_PROCESS.UnRegisterMTableView	Disables the publishing of content from a multitable view as a feature instance.

The rest of this chapter provides reference information on the subprograms, listed in alphabetical order.

SDO_WFS_PROCESS.DropFeatureType

Format

```
SDO_WFS_PROCESS.DropFeatureType(  
    ftnsUrl IN VARCHAR2,  
    ftName IN VARCHAR2);
```

Description

Deletes a specified feature type.

Parameters

ftnsUrl

Uniform resource locator (URL) of the namespace for the feature type.

ftName

Name of the feature type.

Usage Notes

If you want to drop a feature type whose content comes from a multitable view, you must call the [SDO_WFS_PROCESS.UnRegisterMTableView](#) procedure before you call the SDO_WFS_PROCESS.DropFeatureType procedure.

If you want to drop all feature types in the namespace, you can use the [SDO_WFS_PROCESS.DropFeatureTypes](#) procedure.

For information about support for Web Feature Services, see [Chapter 15](#).

Examples

The following example deletes the feature type named COLA in a specified namespace.

```
BEGIN  
    SDO_WFS_PROCESS.dropFeatureType('http://www.example.com/myns', 'COLA');  
END;  
/
```

SDO_WFS_PROCESS.DropFeatureTypes

Format

```
SDO_WFS_PROCESS.DropFeatureTypes(  
    ftnsUrl IN VARCHAR2);
```

Description

Deletes all feature types in a specified namespace.

Parameters

ftnsUrl

Uniform resource locator (URL) of the namespace.

Usage Notes

To drop a single feature type in a namespace, use the [SDO_WFS_PROCESS.DropFeatureType](#) procedure.

For information about support for Web Feature Services, see [Chapter 15](#).

Examples

The following example deletes all feature types in a specified namespace.

```
BEGIN  
    SDO_WFS_PROCESS.dropFeatureTypes('http://www.example.com/myns');  
END;  
/
```

SDO_WFS_PROCESS.GenCollectionProcs

Format

```
SDO_WFS_PROCESS.GenCollectionProcs();
```

Description

Generates helper procedures for relational feature types that have collection-based columns (for example, VARRAYs or nested tables).

Parameters

None.

Usage Notes

Use this procedure if any feature tables have features that are defined in collection-based columns (for example, VARRAYs or nested tables).

For information about support for Web Feature Services, see [Chapter 15](#).

Examples

The following example generates helper procedures for relational feature types that have collection-based columns.

```
BEGIN
  SDO_WFS_PROCESS.GenCollectionProcs;
END;
/
```

SDO_WFS_PROCESS.GetFeatureTypeId

Format

```
SDO_WFS_PROCESS.GetFeatureTypeId(  
    ftnsUrl IN VARCHAR2,  
    ftName IN VARCHAR2) RETURN NUMBER;
```

Description

Gets the feature type ID of a specified feature type.

Parameters

ftnsUrl

Uniform resource locator (URL) of the namespace for the feature type.

ftName

Name of the feature type.

Usage Notes

For information about support for Web Feature Services, see [Chapter 15](#).

Examples

The following example gets the feature type ID of a feature type named COLA.

```
DECLARE  
    ftid number;  
BEGIN  
    ftId := SDO_WFS_PROCESS.GetFeatureTypeId('http://www.example.com/myns', 'COLA');  
END;  
/
```

SDO_WFS_PROCESS.GrantFeatureTypeToUser

Format

```
SDO_WFS_PROCESS.GrantFeatureTypeToUser(  
    ftnsUrl    IN VARCHAR2,  
    ftName     IN VARCHAR2,  
    userName  IN VARCHAR2);
```

Description

Grants access to a feature type to a database user.

Parameters

ftnsUrl

Uniform resource locator (URL) of the namespace for the feature type.

ftName

Name of the feature type.

userName

Name of the database user.

Usage Notes

To revoke access to a feature type from a database user, use the [SDO_WFS_PROCESS.RevokeFeatureTypeFromUser](#) procedure.

For information about support for Web Feature Services, see [Chapter 15](#).

Examples

The following example grants access to the COLA feature type to user SMITH.

```
BEGIN  
    SDO_WFS_PROCESS.GrantFeatureTypeToUser('http://www.example.com/myns', 'COLA',  
        'SMITH');  
END;  
/
```

SDO_WFS_PROCESS.GrantMDAccessToUser

Format

```
SDO_WFS_PROCESS.GrantMDAccessToUser(  
    userName IN VARCHAR2);
```

Description

Grants access to Web Feature Service metadata tables to a database user.

Parameters

userName

Name of the database user.

Usage Notes

To call this procedure, you should be connected to the database as a user with the DBA role.

To revoke access to Web Feature Service metadata tables from a database user, use the [SDO_WFS_PROCESS.RevokeMDAccessFromUser](#) procedure.

For information about support for Web Feature Services, see [Chapter 15](#).

Examples

The following example grants access to Web Feature Service metadata tables to the database user named WFS_REL_USER.

```
BEGIN  
    SDO_WFS_PROCESS.GrantMDAccessToUser('WFS_REL_USER');  
END;  
/
```

SDO_WFS_PROCESS.InsertCapabilitiesInfo

Format

```
SDO_WFS_PROCESS.InsertCapabilitiesInfo(  
    capabilitiesInfo IN XMLTYPE);
```

Description

Inserts the capabilities template information.

Parameters

capabilitiesInfo

XML document for the capabilities template, which is used at runtime to generate capabilities documents.

Usage Notes

At runtime, the capabilities document is dynamically generated by binding feature type information from the WFS metadata with the capabilities template. For information about capabilities documents, see [Section 15.2.1](#).

For information about support for Web Feature Services, see [Chapter 15](#).

Examples

The following example inserts the capabilities template information.

```
BEGIN  
    SDO_WFS_PROCESS.insertCapabilitiesInfo(  
        xmltype(bfilename('WFSUSERDIR', 'capabilitiesTemplate.xml'),  
            nls_charset_id('AL32UTF8')));  
END  
/
```

SDO_WFS_PROCESS.InsertFtDataUpdated

Format

```
SDO_WFS_PROCESS.InsertFtDataUpdated(  
    ns            IN VARCHAR2,  
    name          IN VARCHAR2,  
    updatedRowList IN ROWPOINTERLIST,  
    updateTs      IN TIMESTAMP);
```

Description

Inserts a notification that the data for one or more feature instances was updated in the database.

Parameters

ns

Namespace of the feature type.

name

Name of the feature type.

updatedRowList

Rowids of feature instances that have been updated.

updateTS

Date and time when the data was updated.

Usage Notes

This procedure is used for WFS cache data synchronization.

For information about support for Web Feature Services, see [Chapter 15](#).

Examples

The following example inserts a notification that the data for the feature instances associated with specific rowids in the COLA_MARKETS_CS table was updated in the database.

```
. . .  
begin  
updatedRowIdList:= . . . -- list of rowIds of the  
--           WFS_REL_USER.COLA_MARKETS_CS table  
--           that have been updated.  
. . .  
SDO_WFS_PROCESS.InsertFtDataUpdated(  
    'http://www.example.com/myns', 'COLA', updatedRowIdList, sysdate);  
. . .  
end;  
/
```

SDO_WFS_PROCESS.InsertFtMDUpdated

Format

```
SDO_WFS_PROCESS.InsertFtMDUpdated(  
    ns      IN VARCHAR2,  
    name    IN VARCHAR2,  
    updateTs IN TIMESTAMP);
```

Description

Inserts a notification that the metadata for a feature type was updated in the database.

Parameters

ns

Namespace of the feature type.

name

Name of the feature type.

updateTS

Date and time when the metadata was updated.

Usage Notes

This procedure is used for WFS cache metadata synchronization.

For information about support for Web Feature Services, see [Chapter 15](#).

Examples

The following example inserts a notification that the metadata for the COLA feature type was updated in the database.

```
begin  
SDO_WFS_PROCESS.InsertFtMDUpdated(  
    'http://www.example.com/myns', 'COLA', sysdate);  
end;  
/
```

SDO_WFS_PROCESS.PopulateFeatureTypeXMLInfo

Format

```
SDO_WFS_PROCESS.PopulateFeatureTypeXMLInfo(  
    xmlColTypeXsd IN XMLTYPE,  
    fTypeid       IN NUMBER,  
    columnName   IN VARCHAR2,  
    objPathInfo  IN MDSYS.STRINGLIST);
```

Description

Populates metadata for a relational feature type that has an XMLType column.

Parameters

xmlColTypeXsd

Schema definition of the relational feature type that has an XMLType column.

fTypeid

ID of the relational feature type that has an XMLType column.

columnName

Name of the XMLType column in the feature table

objPathInfo

Path information. The MDSYS.STRINGLIST type is defined as VARRAY(1000000) OF VARCHAR2(4000).

Usage Notes

For information about support for Web Feature Services, see [Chapter 15](#).

Examples

The following example populates the metadata for the relational feature type described by the XML schema definition in `ROADS.xsd` and stored in an XMLType column named `DATAACOL`

```
BEGIN  
    SDO_WFS_PROCESS.populateFeatureTypeXMLInfo(  
        xmltype(bfilename('WFSUSERDIR', 'ROADS.xsd'), nls_charset_id('AL32UTF8')),  
        1,  
        'DATAACOL',  
        mdsys.StringList('METADATA'));  
END;  
/
```

SDO_WFS_PROCESS.PublishFeatureType

Format

```
SDO_WFS_PROCESS.PublishFeatureType(
    dataSrc          IN VARCHAR2,
    ftNsUrl          IN VARCHAR2,
    ftName           IN VARCHAR2,
    ftNsAlias        IN VARCHAR2,
    featureDesc      IN XMLTYPE,
    schemaLocation   IN VARCHAR2,
    pkeyCol          IN VARCHAR2,
    columnInfo       IN MDSYS.STRINGLIST,
    pSpatialCol      IN VARCHAR2,
    featureMemberNs IN VARCHAR2,
    featureMemberName IN VARCHAR2,
    srsNs            IN VARCHAR2,
    srsNsAlias       IN VARCHAR2,
    mandatoryColumnInfo IN MDSYS.STRINGLIST);
```

or

```
SDO_WFS_PROCESS.PublishFeatureType(
    dataSrc          IN VARCHAR2,
    ftNsUrl          IN VARCHAR2,
    ftName           IN VARCHAR2,
    ftNsAlias        IN VARCHAR2,
    featureDesc      IN XMLTYPE,
    schemaLocation   IN VARCHAR2,
    pkeyCol          IN VARCHAR2,
    columnInfo       IN MDSYS.STRINGLIST,
    pSpatialCol      IN VARCHAR2,
    featureMemberNs IN VARCHAR2,
    featureMemberName IN VARCHAR2,
    srsNs            IN VARCHAR2,
    srsNsAlias       IN VARCHAR2,
    viewTableName    IN VARCHAR2,
    viewTablepkeyCol IN VARCHAR2,
    mandatoryColumnInfo IN MDSYS.STRINGLIST);
```

or

```
SDO_WFS_PROCESS.PublishFeatureType(  
    dataSrc          IN VARCHAR2,  
    ftNsUrl          IN VARCHAR2,  
    ftName           IN VARCHAR2,  
    ftNsAlias        IN VARCHAR2,  
    featureDesc      IN XMLTYPE,  
    schemaLocation   IN VARCHAR2,  
    pkeyCol          IN VARCHAR2,  
    columnInfo       IN MDSYS.STRINGLIST,  
    pSpatialCol      IN VARCHAR2,  
    featureMemberNs IN VARCHAR2,  
    featureMemberName IN VARCHAR2,  
    srsNs            IN VARCHAR2,  
    srsNsAlias       IN VARCHAR2,  
    featureCollectionNs IN VARCHAR2,  
    featureCollectionName IN VARCHAR2,  
    isGML3           IN VARCHAR2,  
    formattedKeyCols IN MDSYS.STRINGLIST,  
    viewTableName    IN VARCHAR2,  
    viewTablepkeyCol IN VARCHAR2,  
    viewTableFmtKeyCols IN VARCHAR2,  
    mandatoryColumnInfo IN MDSYS.STRINGLIST);
```

Description

Publishes a feature type; that is, registers metadata related to the feature type.

Parameters

dataSrc

Name of the feature table or view containing the spatial features. It must be in the format *schema-name.table-name* or *schema-name.view-name*; that is, the name of the database user that owns the table must be included.

ftNsUrl

Uniform resource locator (URL) of the namespace for the feature type.

ftName

Name of the feature type.

ftNsAlias

Alias of the namespace for the feature type.

featureDesc

Feature type description to be reported in the capabilities document, as a document of type XMLTYPE.

schemaLocation

String to be used to populate the `xsi:schemaLocation` attribute in the feature type XSD. If this parameter is null, a string is automatically generated.

pkeyCol

Primary key column in the feature table or view identified in `dataSrc`. If a feature type table or view has a multicolumn primary key, use a semicolon to separate the columns in the primary key. For example: 'COL1;COL2'

columnInfo

Type string associated with each spatial column (SDO_GEOMETRY type) in the feature table identified in `dataSrc`, as an object of type MDSYS.STRINGLIST (for example, for WFS 1.0.n, `MDSYS.STRINGLIST ('<GEOM_COL1_GEOMETRYTYPE>PolygonMemberType', '<GEOM_COL2_GEOMETRYTYPE>PointMemberType')`).

See the Usage Notes for information about any spatial columns specified in the `columnInfo` parameter.

pSpatialCol

Spatial column of type SDO_GEOMETRY in the feature table.

featureMemberNs

Namespace of the feature member element that will contain feature instances in a feature collection. If this parameter is null, the default is:
`http://www.opengis.net/gml`

featureMemberName

Name of the feature member element that will contain feature instances in a feature collection. If this parameter is null, the default is `featureMember`.

srsNs

User-defined namespace of the spatial reference system (coordinate system) associated with the spatial data for the feature type. This namespace (if specified) is also used to generate the `srsName` attribute in the `<boundedBy>` element of the `FeatureCollection` result generated for the `GetFeature` request.

srsNsAlias

Namespace alias of the namespace of the spatial reference system (coordinate system) associated with the spatial data for the feature type.

featureCollectionNs

Namespace of the WFS feature collection within which this feature type instances can occur.

featureCollectionName

Name of the WFS feature collection within which this feature type instances can occur.

isGML3

A string value: Y means that the geometries inside instances of this feature type are GML3.1.1 compliant; N means that the geometries inside instances of this feature type are GML 2.1.2 compliant.

formattedKeyCols

String formatted representation of the content of the primary key column or (for a multicolumn primary key) columns. For example, if ROAD_ID is the primary key column of type NUMBER, specify `MDSYS.STRINGLIST('to_char(ROAD_ID)')`. To specify multiple strings in the `MDSYS.STRINGLIST` type constructor, separate each with a comma. The list of string formatted primary key columns should be specified in the same order as the primary key columns specified in the `pkeyCol` parameter.

viewTableName

Name of the underlying table if the feature type will be defined on a view based on a single underlying table. The published feature type will be based on the view, specified in the `dataSrc` parameter (*user-name.view-name*). Do not enter a value for the `viewTableName` parameter if the feature type is based on a table or on a multitable view.

viewTablepkeyCol

Primary key column of the table specified in the `viewTableName` parameter, if the feature type will be defined on a view based on a single underlying table.

viewTableFmtKeyCols

If the feature type is based on a view defined on a single table, and if the view has one or more formatted primary key columns, this parameter represents a list of string formatted primary key columns in the underlying table that correspond to the string formatted primary key columns in the view (specified by `formattedkeyCols` parameter). For example, if ROAD_ID is the primary key column of type NUMBER, specify `MDSYS.STRINGLIST('to_char(ROAD_ID)')`. To specify multiple strings in the `MDSYS.STRINGLIST` type constructor, separate each with a comma.

If feature type is not based on a single table view, or if the feature type is based on a single table view but the feature type does not have formatted primary key columns, this parameter should be null.

mandatoryColumnInfo

List of columns that must be returned in the GetFeature request, irrespective of the columns requested. (The requested columns will be returned in all cases.) If this parameter is omitted, all columns are mandatory (that is, all columns will be returned). However, if this parameter is specified as NULL, no columns are mandatory (that is, only the requested columns will be returned). To specify column names, use the `MDSYS.STRINGLIST` type constructor as in the following example:
`MDSYS.STRINGLIST('COL1', 'COL2', 'COL5')`

Usage Notes

In the `columnInfo` parameter, each column of type `SDO_GEOMETRY` in the feature type instances table must have the correct associated string value specified in the `columnInfo` parameter, with the string values in the same order as the order of the spatial columns in the table definition.

For WFS 1.0.*n*, for example, if the single `SDO_GEOMETRY` column named SHAPE in the feature type instances table contains polygon geometries, the `columnInfo` value must be `SHAPE_GEOMETRYTYPE>PolygonMemberType`. [Table 34–2](#) lists the geometry types and their required associated `columnInfo` parameter values for WFS version 1.0.*n*. (Replace *<column-name>* with the name of the column.)

Table 34–2 Geometry Types and columnInfo Parameter Values (WFS 1.0.n)

Geometry Type	columnInfo Parameter Value
Polygon or Surface	<column-name>_GEOMETRYTYPE>PolygonMemberType
Multipolygon or Multisurface	<column-name>_GEOMETRYTYPE>MultiPolygonMemberType
Point	<column-name>_GEOMETRYTYPE>PointMemberType
Multipoint	<column-name>_GEOMETRYTYPE>MultiPointMemberType
Line or Curve	<column-name>_GEOMETRYTYPE>CurveMemberType
Multiline or multicurve	<column-name>_GEOMETRYTYPE>MultiCurveMemberType
Solid	<column-name>_GEOMETRYTYPE>SolidMemberType
Multisolid	<column-name>_GEOMETRYTYPE>MultiSolidMemberType
Collection	<column-name>_GEOMETRYTYPE>GeometryMemberType

For information about support for Web Feature Services, see [Chapter 15](#).

Examples

The following example registers metadata for a feature type named COLA with the polygon geometries stored in the column named SHAPE. (It assumes the use of WFS 1.0.n.)

```

DECLARE
columnInfo MDSYS.StringList := MDSYS.StringList('SHAPE_
GEOMETRYTYPE>PolygonMemberType');
BEGIN
SDO_WFS_PROCESS.publishFeatureType(
  'WFS_USER.COLA_MARKETS_VIEW',
  'http://www.example.com/myns',
  'COLA',
  'myns',
  xmltype(bfilename('WFSUSERDIR', 'featuredesc.xml'), nls_charset_id('AL32UTF8')),
  null, 'MKT_ID', columnInfo, 'SHAPE', null, null, null, null);
END;
/

```

SDO_WFS_PROCESS.RegisterMTableView

Format

```
SDO_WFS_PROCESS.RegisterMTableView(  
    ftNsUrl          IN VARCHAR2,  
    ftName           IN VARCHAR2,  
    viewTableList    IN MDSYS.STRINGLIST,  
    viewTablePkeyCollist IN MDSYS.STRINGLIST,  
    tablePkeyCollist IN MDSYS.STRINGLIST);
```

or

```
SDO_WFS_PROCESS.RegisterMTableView(  
    ftNsUrl          IN VARCHAR2,  
    ftName           IN VARCHAR2,  
    viewTableList    IN MDSYS.STRINGLIST,  
    viewTablePkeyCollist IN MDSYS.STRINGLIST,  
    formattedViewTableCollist IN MDSYS.STRINGLISTLIST,  
    tablePkeyCollist IN MDSYS.STRINGLIST);
```

Description

Enables the publishing of content from a multitable view as a feature instance.

Parameters

ftNsUrl

Uniform resource locator (URL) of the namespace for the feature type.

ftName

Name of the feature type.

viewTableList

List of tables in the view. To specify table names, use the MDSYS.STRINGLIST type constructor as in the following example: MDSYS.STRINGLIST('MYUSER.ROADS', 'MYUSER.ROADS_DESC')

viewTablePkeyCollist

List of view columns that correspond to the primary key columns in the tables in the view, in the order that corresponds to the order of the tables in `viewTableList`. To specify column names, use the MDSYS.STRINGLIST type constructor as in the following example: MDSYS.STRINGLIST('ROAD_ID', 'ROAD_ID'), where both the ROADS and ROAD_DESC table have ROAD_ID as primary key.

If the view has columns that correspond to table columns in a multicolumn primary key, use a semicolon to separate the columns in the primary key. For example:

```
'COL1 ; COL2 '
```

formattedViewTableColList

A list of string formatted table primary key columns that correspond to the string formatted primary key columns in the view, in the order that corresponds to the order of the tables in `viewTableList`. To specify column names, use the `MDSYS.STRINGLISTLIST` type constructor as in the following example:

```
MDSYS.STRINGLISTLIST(MDSYS.STRINGLIST('to_char(ROAD_ID)'),
MDSYS.STRINGLIST('to_char(ROAD_ID)'))
```

The list of string formatted primary key columns for each table should be specified in the same order as the primary key columns for each table specified in `tablePkeyColList` parameter.

tablePkeyColList

List of the primary key columns in the tables, in the order that corresponds to the order of the tables in `viewTableList`. For each table the primary key columns should be specified in the order that correspond to the key columns in the view as specified in `viewTablePkeyColList` parameter. To specify column names, use the `MDSYS.STRINGLIST` type constructor as in the following example:

```
MDSYS.STRINGLIST('ROAD_ID', 'ROAD_ID')
```

If a table has a multicolumn primary key, use a semicolon to separate the columns in the primary key. For example: `'COL1;COL2'`

Usage Notes

If you need to publish content from a multitable view as a feature instance, you must call this procedure after calling the [SDO_WFS_PROCESS.PublishFeatureType](#) procedure.

To disable the publishing of content from a multitable view as a feature instance, use the [SDO_WFS_PROCESS.UnRegisterMTableView](#) procedure.

For information about support for Web Feature Services, see [Chapter 15](#).

Examples

The following example creates two feature tables, creates a view based on these tables, publishes a feature type, and registers the multitable view to enable the publishing of content from the view.

```
CREATE TABLE cola_markets_cs (
  mkt_id NUMBER PRIMARY KEY,
  name VARCHAR2(32),
  shape MDSYS.SDO_GEOMETRY);

CREATE TABLE cola_markets_cs_details (
  mkt_id NUMBER PRIMARY KEY,
  description VARCHAR2(400));

create view cola_markets_view as select t1.mkt_id, t1.name, t1.shape,
  t2.description from
  cola_markets_cs t1, cola_markets_cs_details t2
  where t1.mkt_id = t2.mkt_id;

DECLARE
cm MDSYS.StringList := MDSYS.StringList('PolygonMemberType');
BEGIN
SDO_WFS_PROCESS.publishFeatureType(
  'WFS_USER.COLA_MARKETS_VIEW',
  'http://www.example.com/myns',
```

```
'COLA',
'myns',
xmltype(bfilename('WFSUSERDIR', 'featuredesct.xml'), nls_charset_id('AL32UTF8')),
null, 'MKT_ID', cm, 'SHAPE', null, null, null, null);
END;
/

BEGIN
SDO_WFS_PROCESS.registerMTableView('http://www.example.com/myns',
'COLA', mdsys.StringList('WFS_USER.COLA_MARKETS_CS',
'WFS_USER.COLA_MARKETS_CS_DETAILS'),
mdsys.StringList('MKT_ID', 'MKT_ID'), -- view keys per table
mdsys.StringList('MKT_ID', 'MKT_ID'));-- corresponding table keys
END;
/
```

SDO_WFS_PROCESS.RevokeFeatureTypeFromUser

Format

```
SDO_WFS_PROCESS.RevokeFeatureTypeFromUser(  
    ftnsUrl    IN VARCHAR2,  
    ftName     IN VARCHAR2,  
    userName  IN VARCHAR2);
```

Description

Revokes access to a feature type from a database user.

Parameters

ftnsUrl

Uniform resource locator (URL) of the namespace for the feature type.

ftName

Name of the feature type.

userName

Name of the database user.

Usage Notes

To grant access to a feature type to a database user, use the [SDO_WFS_PROCESS.GrantFeatureTypeToUser](#) procedure.

For information about support for Web Feature Services, see [Chapter 15](#).

Examples

The following example revokes access to the COLA feature type from user SMITH.

```
BEGIN  
    SDO_WFS_PROCESS.RevokeFeatureTypeFromUser('http://www.example.com/myns', 'COLA',  
        'SMITH');  
END;  
/
```

SDO_WFS_PROCESS.RevokeMDAccessFromUser

Format

```
SDO_WFS_PROCESS.RevokeMDAccessFromUser(  
    userName IN VARCHAR2);
```

Description

Revokes access to Web Feature Service metadata tables from a database user.

Parameters

userName

Name of the database user.

Usage Notes

To call this procedure, you should be connected to the database as a user with the DBA role.

To grant access to Web Feature Service metadata tables to a database user, use the [SDO_WFS_PROCESS.GrantMDAccessToUser](#) procedure.

For information about support for Web Feature Services, see [Chapter 15](#).

Examples

The following example revokes access to Web Feature Service metadata tables from the database user named WFS_REL_USER.

```
BEGIN  
    SDO_WFS_PROCESS.RevokeMDAccessToUser ('WFS_REL_USER');  
END;  
/
```

SDO_WFS_PROCESS.UnRegisterMTableView

Format

```
SDO_WFS_PROCESS.UnRegisterMTableView(  
    ftNsUrl          IN VARCHAR2,  
    ftName           IN VARCHAR2);
```

Description

Disables the publishing of content from a multitable view as a feature instance.

Parameters

ftNsUrl

Uniform resource locator (URL) of the namespace for the feature type.

ftName

Name of the feature type.

Usage Notes

The [SDO_WFS_PROCESS.RegisterMTableView](#) procedure must have been called previously to enable the publishing of content from the multitable view as a feature instance.

If you want to drop a feature type whose content comes from a multitable view, you must call this procedure before you call the [SDO_WFS_PROCESS.DropFeatureType](#) procedure.

For information about support for Web Feature Services, see [Chapter 15](#).

Examples

The following example unregisters a multitable view to disable the publishing of content from the view.

```
DECLARE  
BEGIN  
    SDO_WFS_PROCESS.unRegisterMTableView('http://www.example.com/myns', 'COLA');  
END;  
/
```

Part IV

Supplementary Information

This document has the following parts:

- [Part I](#) provides conceptual and usage information about Oracle Spatial.
- [Part II](#) provides conceptual and usage information about Oracle Spatial Web services.
- [Part III](#) provides reference information about Oracle Spatial operators, functions, and procedures.
- Part IV provides supplementary information (appendixes and a glossary).

Part IV contains the following:

- [Appendix A, "Installation, Compatibility, and Upgrade"](#)
- [Appendix B, "Oracle Locator"](#)
- [Appendix C, "Complex Spatial Queries: Examples"](#)
- [Appendix D, "Loading ESRI Shapefiles into Spatial"](#)
- [Glossary](#)

Installation, Compatibility, and Upgrade

If you are upgrading to Oracle Database 11g, Oracle Spatial is automatically upgraded as part of the operation. For information about the upgrade procedure, see *Oracle Database Upgrade Guide*.

If you need to downgrade Spatial to the previous Oracle Database release, follow the instructions for downgrading a database back to the previous Oracle Database release in *Oracle Database Upgrade Guide*.

If you use Oracle Spatial GeoRaster, see [Section A.1](#).

If you are using Spatial Web Feature Service (WFS) or Catalog Services for the Web (CSW) support, and if you have data from a previous release that was indexed using one or more SYS.XMLTABLEINDEX indexes, see [Section A.2](#).

If you need to support geometries with more than 1,048,576 ordinates, see [Section A.3](#).

A.1 Ensuring That GeoRaster Works Properly After an Installation or Upgrade

To use the GeoRaster feature of Oracle Spatial, Oracle XML DB Repository must be installed properly. (In general, you should ensure that Oracle XML DB Repository is installed before you install Oracle Spatial.)

If Oracle Spatial has been installed (such as during an upgrade) but Oracle XML DB Repository is not installed, you need to install the Oracle XML DB Repository and reload related GeoRaster PL/SQL packages. In this case, follow these steps

1. Install Oracle XML DB Repository.

For information about installing and uninstalling Oracle XML DB Repository, see *Oracle XML DB Developer's Guide*.

2. Go to the `$ORACLE_HOME/md/admin` directory.
3. Connect to the database as `SYS AS SYSDBA`.
4. Enter the following SQL statements:

```
ALTER SESSION SET CURRENT_SCHEMA=MDSYS;
@prvtgrs.plb
@sdogrxml.sql
```

A.2 Index Maintenance Before and After an Upgrade (WFS and CSW)

Effective with Release 11.2, the SYS.XMLTABLEINDEX index type is deprecated, and therefore the Spatial WFS and CSW `createXMLTableIndex` methods create indexes

of type `XDB.XMLINDEX` instead of type `SYS.XMLTABLEINDEX` as in previous releases. However, if you have data from a previous release that was indexed using one or more `SYS.XMLTABLEINDEX` indexes, you must drop the associated indexes before the upgrade and re-create the indexes after the upgrade, as follows:

1. Using Oracle Database Release 11.1, call the `dropXMLTableIndex` method (in `oracle.spatial.csw.CSWAdmin` or `oracle.spatial.wfs.WFSAdmin`, as appropriate depending on the application) to drop associated indexes.
2. Upgrade the database from Release 11.1 to Release 11.2.
3. Using Oracle Database Release 11.2, call the `createXMLTableIndex` (in `oracle.spatial.csw.CSWAdmin` or `oracle.spatial.wfs.WFSAdmin`, as appropriate depending on the application) to create indexes that were dropped in step 1.

For information about Spatial Web Feature Service (WFS) support, see [Chapter 15](#), and especially the following:

- `createXMLTableIndex` method ([Section 15.4.1](#))
- `dropXMLTableIndex` method ([Section 15.4.3](#))
- `getIsXMLTableIndexCreated` method ([Section 15.4.4](#))
- `genXMLIndex` and `idxPaths` parameters of the `publishFeatureType` method ([Section 15.4.7](#))
- `setXMLTableIndexInfo` method ([Section 15.4.10](#))

For information about Spatial Catalog Services for the Web (CSW) support, see [Chapter 16](#), and especially the following:

- `createXMLTableIndex` method ([Section 16.4.1](#))
- `dropXMLTableIndex` method ([Section 16.4.6](#))
- `getIsXMLTableIndexCreated` method ([Section 16.4.8](#))
- `genXMLIndex` and `idxPaths` parameters of the `publishRecordType` method ([Section 16.4.12](#))
- `setXMLTableIndexInfo` method ([Section 16.4.19](#))

A.3 Increasing the Size of Ordinate Arrays to Support Very Large Geometries

If you need to support geometries with more than 1,048,576 ordinates, you must follow the instructions in this section. However, doing so involves significant extra work (running a script, migrating existing spatial data), some database downtime, and some considerations and restrictions. Therefore, you should not perform the actions in this section unless you need to.

To increase the size of ordinate arrays to support geometries with up to 10M ordinates, follow these steps:

1. Ensure that no users are using any spatial tables or Oracle Spatial or Locator features.
2. Connect to the database as the SYS user with SYSDBA privileges (SYS AS SYSDBA, and enter the SYS account password when prompted).
3. Enter the following statement:

- Linux: @\$ORACLE_HOME/md/admin/sdoupggeom.sql
- Windows: @%ORACLE_HOME%\md\admin\sdoupggeom.sql

One of the actions of the `sdoupggeom.sql` script is to automatically migrate all spatial data to accommodate the new `SDO_ORDINATE_ARRAY` definition. This script may take a long time to complete, and the amount of time will depend on the amount of spatial data that exists in the database.

After you perform these steps, the following considerations and restrictions apply:

- Any existing transportable tablespaces that were created with the old `SDO_ORDINATE_ARRAY` definition will not work.
- If an export file was created using the Original Export utility on a database with the old `SDO_ORDINATE_ARRAY` definition, and if that file needs to be imported into a database that is using the new `SDO_ORDINATE_ARRAY` definition, you must specify the `TOID_NOVALIDATE` flag with the Original Import utility, as in the following example:

```
imp scott/<password> file=states.dmp tables=states TOID_NOVALIDATE=MDSYS.SDO_
GEOMETRY,MDSYS.SDO_ORDINATE_ARRAY,MDSYS.SDO_ELEM_INFO_ARRAY
```

Oracle Locator

Oracle Locator (also referred to as Locator) is a feature of Oracle Database 11g Standard Edition. Locator provides core features and services available in Oracle Spatial. It provides significant capabilities typically required to support Internet and wireless service-based applications and partner-based GIS solutions. Locator is not designed to be a solution for geographic information system (GIS) applications requiring complex spatial data management. If you need capabilities such as linear referencing, advanced spatial functions, or Spatial Web services, use Oracle Spatial instead of Locator.

Like Spatial, Locator is not designed to be an end-user application, but is a set of spatial capabilities for application developers.

Locator is available with the Standard Edition One, Standard Edition, and Enterprise Edition of Oracle Database, and with Oracle Database XE (Express Edition). Spatial is a priced option available only with Oracle Database 11g Enterprise Edition. Spatial includes all Locator features as well as other features that are not available with Locator.

If you want to ensure that you are using only features available in Locator, see [Section B.1, "Installing and Deinstalling Locator or Spatial Manually"](#). For licensing information about Spatial and Locator, see *Oracle Database Licensing Information*.

The installation of Locator depends on the successful and proper installation of Oracle Multimedia. Oracle Multimedia is installed and configured with Oracle Database 11g, although you can install Oracle Multimedia manually if necessary, as documented in *Oracle Multimedia User's Guide*. During the installation of Oracle Multimedia, Locator is installed.

In general, Locator includes the data types, operators, and indexing capabilities of Oracle Spatial, along with a limited set of the subprograms (functions and procedures) of Spatial. The Locator features include the following:

- An object type (SDO_GEOMETRY) that describes and supports any type of geometry
- A spatial indexing capability that lets you create spatial indexes on geometry data
- Spatial operators (described in [Chapter 19](#)) that use the spatial index for performing spatial queries
- Most geometry functions and spatial aggregate functions (as explained in [Table B-1](#))
- Coordinate system support for geometry and layer transformations (SDO_CS.TRANSFORM function and SDO_CS.TRANSFORM_LAYER procedure, described in [Chapter 21](#))

- Tuning subprograms (SDO_TUNE package, described in [Chapter 31](#))
- Spatial utility functions (SDO_UTIL package, described in [Chapter 32](#))
- Classes in the `oracle.spatial.geometry` (`sdoapi.jar`) and `oracle.spatial.util` (`sdoutil.jar`) packages of the Spatial Java API (described in *Oracle Spatial Java API Reference*)

For information about spatial concepts, the SDO_GEOMETRY object type, support for SQL Multimedia types annotation text, and indexing and loading of spatial data, see Chapters 1 through 5 in this guide. For reference and usage information about features supported by Locator, see the chapter or section listed in [Table B-1](#).

Table B-1 Spatial-Related Features Supported for Locator

Feature	Described in
Spatial operators (including SDO_JOIN , which is technically a table function but is documented with the operators)	Chapter 19
All SDO_GEOM package subprograms <i>except for</i> the following: SDO_GEOM.RELATE , SDO_GEOM.SDO_DIFFERENCE , SDO_GEOM.SDO_INTERSECTION , SDO_GEOM.SDO_UNION , SDO_GEOM.SDO_VOLUME , SDO_GEOM.SDO_XOR	Chapter 24
Spatial aggregate functions, except for SDO_AGGR_SET_UNION and SDO_AGGR_UNION	Chapter 20
Coordinate system transformation subprograms (SDO_CS package)	Chapter 21
Implicit coordinate system transformations for operator calls where a window needs to be converted to the coordinate system of the queried layer	Chapter 19
Function-based spatial indexing	Section 9.2
Table partitioning support for spatial indexes (including splitting, merging, and exchanging partitions and their indexes)	Section 5.1.3 and Section 5.1.4
Geodetic data support	Section 6.2 and Section 6.8
SQL statements for creating, altering, and deleting indexes	Chapter 18
Parallel spatial index builds (PARALLEL keyword with ALTER INDEX REBUILD and CREATE INDEX statements) (new with release 9.2)	Chapter 18
SDO_GEOMETRY object type methods	Section 2.3
SQL Multimedia spatial types (ST_xxx types)	Chapter 3
SQL Multimedia functions (ST_xxx functions) whose Oracle Spatial counterparts are supported for Locator	Section 3.2
Annotation text	Section 3.5
Package (SDO_MIGRATE) to upgrade data from previous Spatial releases to the current release	Chapter 26
Tuning subprograms (SDO_TUNE package)	Chapter 31
Spatial utility functions (SDO_UTIL package)	Chapter 32
Classes in the <code>oracle.spatial.geometry</code> (<code>sdoapi.jar</code>) and <code>oracle.spatial.util</code> (<code>sdoutil.jar</code>) packages of the Spatial Java API	<i>Oracle Spatial Java API Reference</i>

Table B–1 (Cont.) Spatial-Related Features Supported for Locator

Feature	Described in
Object replication	<i>Oracle Database Advanced Replication</i>

Table B–2 lists Spatial features that are *not* supported for Locator, with the chapter in this guide or the separate manual that describes the feature.

Table B–2 Spatial Features Not Supported for Locator

Feature	Described in
The following SDO_GEOM package subprograms: SDO_GEOM.RELATE, SDO_GEOM.SDO_DIFFERENCE, SDO_GEOM.SDO_INTERSECTION, SDO_GEOM.SDO_UNION, SDO_GEOM.SDO_VOLUME, SDO_GEOM.SDO_XOR	Chapter 24
SDO_AGGR_UNION spatial aggregate function	Chapter 20
Linear referencing system (LRS) support	Chapter 7 (concepts and usage) and Chapter 25 (reference)
Three-dimensional geometry support: the use of 3D spatial indexing, 3D operators, and subprograms on 3D data is not supported for Locator.	Section 1.11 (3D concepts and usage)
Spatial analysis and mining subprograms (SDO_SAM package)	Chapter 29
OpenLS support, including support for geocoding, mapping, business directory (Yellow Pages), and driving directions (routing) services	Chapter 14, "OpenLS Support" and Chapter 27, "SDO_OLS Package (OpenLS)". See also: <ul style="list-style-type: none"> ▪ Chapter 11, "Geocoding Address Data" and Chapter 23, "SDO_GCDR Package (Geocoding)" ▪ Chapter 12, "Business Directory (Yellow Pages) Support" ▪ Chapter 13, "Routing Engine"
Web feature service (WFS) support (SDO_WFS_PROCESS and SDO_WFS_LOCK packages)	Chapter 15 (concepts and usage), and Chapter 34 and Chapter 33 (reference)
Catalog services for the Web (CSW) support (SDO_CSW_PROCESS package)	Chapter 16 (concepts and usage) and Chapter 22 (reference)
Triangulated irregular network (TIN) and point cloud (PC) data types and related subprograms	Section 1.11 (concepts and usage), and Chapter 30 (SDO_TIN_PKG reference) and Chapter 28 (SDO_PC_PKG reference)
GeoRaster support	<i>Oracle Spatial GeoRaster Developer's Guide</i>
Topology data model	<i>Oracle Spatial Topology and Network Data Models Developer's Guide</i>
Network data model	<i>Oracle Spatial Topology and Network Data Models Developer's Guide</i>
Classes in packages <i>other than</i> the oracle.spatial.geometry (sdoapi.jar) and oracle.spatial.util (sdoutil.jar) packages of the Spatial Java API	<i>Oracle Spatial Java API Reference</i>

Although Locator is available on both the Standard and Enterprise Editions of Oracle Database 11g, some Locator features require database features that are not available or are limited on the Standard Edition. Some of those Locator features and their availability are listed in [Table B-3](#).

Table B-3 Feature Availability with Standard or Enterprise Edition

Feature	Standard/Enterprise Edition Availability
Parallel spatial index builds	Supported with Enterprise Edition only.
Multimaster replication of SDO_GEOMETRY objects	Supported with Enterprise Edition only. (Single master/materialized view replication for SDO_GEOMETRY objects is supported with both Standard Edition and Enterprise Edition. See <i>Oracle Database Advanced Replication</i> for more information.)
Partitioned spatial indexes	Requires the Partitioning Option with Enterprise Edition. Not supported with Standard Edition.

B.1 Installing and Deinstalling Locator or Spatial Manually

To install Spatial or to use any features that are specific to Spatial but not Locator, you must meet the licensing requirements for Spatial. For licensing information about Spatial and Locator, see *Oracle Database Licensing Information*.

Scripts are available to perform certain installation and deinstallation operations relating to Locator and Spatial:

- `mddins.sql` manually deinstalls Spatial and leaves only Locator, thus "installing" only Locator. This ensures that you can use only features available in Locator and no features that are available only with Spatial.
- `mdinst.sql` manually installs Spatial, so that you are able to use all features available with Spatial and Locator.

If you want to ensure that you are using only Locator features, but Spatial is already installed, run the `mddins.sql` script, as follows:

1. Ensure that Oracle Multimedia is installed.
2. Connect to the database as the SYS user with SYSDBA privileges (SYS AS SYSDBA, and enter the SYS account password when prompted).
3. Start SQL*Plus, and enter the following statement:
 - Linux: `@$ORACLE_HOME/md/admin/mddins.sql`
 - Windows: `:@ORACLE_HOME%\md\admin\mddins.sql`

If you need to be able to use Spatial, you can run the `mdinst.sql` script, as follows:

1. Connect to the database as the SYS user with SYSDBA privileges (SYS AS SYSDBA, and enter the SYS account password when prompted).
2. Start SQL*Plus, and enter the following statement:
 - Linux: `@$ORACLE_HOME/md/admin/mdinst.sql`
 - Windows: `:@ORACLE_HOME%\md\admin\mdinst.sql`

Complex Spatial Queries: Examples

This appendix provides examples, with explanations, of queries that are more complex than the examples in the reference chapters in [Part III, "Reference Information"](#). This appendix focuses on operators that are frequently used in Spatial applications, such as [SDO_WITHIN_DISTANCE](#) and [SDO_NN](#).

This appendix is based on input from Oracle personnel who provide support and training to Spatial users. The Oracle Spatial training course covers many of these examples, and provides additional examples and explanations.

Before you use any of the examples in this appendix, be sure you understand the usage and reference information for the relevant operator or function in [Part I, "Conceptual and Usage Information"](#) and [Part III, "Reference Information"](#).

This appendix contains the following major sections:

- [Section C.1, "Tables Used in the Examples"](#)
- [Section C.2, "SDO_WITHIN_DISTANCE Examples"](#)
- [Section C.3, "SDO_NN Examples"](#)
- [Section C.4, "SDO_AGGR_UNION Example"](#)

C.1 Tables Used in the Examples

The examples in this appendix refer to tables named `GEOD_CITIES`, `GEOD_COUNTIES`, and `GEOD_INTERSTATES`, which are defined as follows:

```
CREATE TABLE GEOD_CITIES (
  LOCATION      SDO_GEOMETRY,
  CITY          VARCHAR2 (42) ,
  STATE_ABRV    VARCHAR2 (2) ,
  POP90         NUMBER,
  RANK90        NUMBER);

CREATE TABLE GEOD_COUNTIES (
  COUNTY_NAME   VARCHAR2 (40) ,
  STATE_ABRV    VARCHAR2 (2) ,
  GEOM          SDO_GEOMETRY);

CREATE TABLE GEOD_INTERSTATES (
  HIGHWAY       VARCHAR2 (35) ,
  GEOM          SDO_GEOMETRY);
```

C.2 SDO_WITHIN_DISTANCE Examples

The `SDO_WITHIN_DISTANCE` operator identifies the set of spatial objects that are within some specified distance of a given object. You can indicate that the distance is approximate or exact. If you specify `querytype=FILTER`, the distance is approximate because only a primary filter operation is performed; otherwise, the distance is exact because both primary and secondary filtering operations are performed.

[Example C-1](#) finds all cities within 15 miles of the interstate highway I170.

Example C-1 Finding All Cities Within a Distance of a Highway

```
SELECT /*+ ORDERED */ c.city
FROM geod_interstates i, geod_cities c
WHERE i.highway = 'I170'
      AND sdo_within_distance (
          c.location, i.geom,
          'distance=15 unit=mile') = 'TRUE';
```

[Example C-1](#) finds all cities within 15 miles ('distance=15 unit=mile') of the specified highway (`i.highway = 'I170'`), and by default the result is exact (because the `querytype` parameter was not used to limit the query to a primary filter operation). In the `WHERE` clause of this example:

- `i.highway` refers to the `HIGHWAY` column of the `INTERSTATES` table, and `I170` is a value from the `HIGHWAY` column.
- `c.location` specifies the search column (`geometry1`). This is the `LOCATION` column of the `GEOD_CITIES` table.
- `i.geom` specifies the query window (`aGeom`). This is the spatial geometry in the `GEOM` column of the `GEOD_INTERSTATES` table, in the row whose `HIGHWAY` column contains the value `I170`.

[Example C-2](#) finds all interstate highways within 15 miles of the city of Tampa.

Example C-2 Finding All Highways Within a Distance of a City

```
SELECT /*+ ORDERED */ i.highway
FROM geod_cities c, geod_interstates i
WHERE c.city = 'Tampa'
      AND sdo_within_distance (
          i.geom, c.location,
          'distance=15 unit=mile') = 'TRUE';
```

[Example C-2](#) finds all highways within 15 miles ('distance=15 unit=mile') of the specified city (`c.city = 'Tampa'`), and by default the result is exact (because the `querytype` parameter was not used to limit the query to a primary filter operation). In the `WHERE` clause of this example:

- `c.city` refers to the `CITY` column of the `GEOD_CITIES` table, and `Tampa` is a value from the `CITY` column.
- `i.geom` specifies the search column (`geometry1`). This is the `GEOM` column of the `GEOD_INTERSTATES` table.
- `c.location` specifies the query window (`aGeom`). This is the spatial geometry in the `LOCATION` column of the `GEOD_CITIES` table, in the row whose `CITY` column contains the value `Tampa`.

C.3 SDO_NN Examples

The `SDO_NN` operator determines the nearest neighbor geometries to a geometry. No assumptions should be made about the order of the returned results, unless you specify the `SDO_NN_DISTANCE` ancillary operator in the `ORDER BY` clause to have the results returned in distance order. If you specify no optional parameters, one nearest neighbor geometry is returned.

If you specify the optional `sdo_num_res` keyword, you can request how many nearest neighbors you want, but no other conditions in the `WHERE` clause are evaluated. For example, assume that you want the five closest banks from an intersection, but only where the bank name is `CHASE`. If the five closest banks are not named `CHASE`, `SDO_NN` with `sdo_num_res=5` will return no rows because the `sdo_num_res` keyword only takes proximity into account, and not any other conditions in the `WHERE` clause.

If you specify the optional `sdo_batch_size` keyword, any `sdo_num_res` specification is ignored, and `SDO_NN` keeps returning neighbor geometries in distance order to the `WHERE` clause. If the `WHERE` clause specifies `bank_name = 'CHASE' AND rownum < 6`, you can return the five closest banks with `bank_name = 'CHASE'`.

`SDO_NN_DISTANCE` is an ancillary operator to the `SDO_NN` operator. It returns the distance of an object returned by the `SDO_NN` operator and is valid only within a call to the `SDO_NN` operator.

Example C-3 finds the five cities nearest to the interstate highway I170 and the distance in miles from the highway for each city, ordered by distance in miles.

Example C-3 Finding the Cities Nearest to a Highway

```
SELECT /*+ ORDERED */
       c.city,
       sdo_nn_distance (1) distance_in_miles
FROM   geod_interstates i,
       geod_cities c
WHERE  i.highway = 'I170'
       AND sdo_nn(c.location, i.geom,
                 'sdo_num_res=5 unit=mile', 1) = 'TRUE'
ORDER BY distance_in_miles;
```

In **Example C-3**, because the `/*+ ORDERED*/` optimizer hint is used, it is important to have an index on the `GEOD_INTERSTATES.HIGHWAY` column. In this example, the hint forces the query to locate highway I170 before it tries to find nearest neighbor geometries. In the `WHERE` clause of this example:

- `i.highway` refers to the `HIGHWAY` column of the `GEOD_INTERSTATES` table, and `I170` is a value from the `HIGHWAY` column.
- `c.location` specifies the search column (`geometry1`). This is the `LOCATION` column of the `GEOD_CITIES` table.
- `i.geom` specifies the query window (`geometry2`). This is the spatial geometry in the `GEOM` column of the `GEOD_INTERSTATES` table, in the row whose `HIGHWAY` column contains the value `I170`.
- `sdo_num_res=5` specifies how many nearest neighbor geometries to find.
- `unit=mile` specifies the unit of measurement to associate with distances returned by the `SDO_NN_DISTANCE` ancillary operator.

- 1 (in `sdo_nn_distance (1)` and `'sdo_num_res=5 unit=mile', 1`) is the number parameter value that associates the call to `SDO_NN` with the call to `SDO_NN_DISTANCE`.

In [Example C-3](#), `ORDER BY distance_in_miles` orders the results from the `WHERE` clause by distance in miles.

The statement in [Example C-3](#) produces the following output (slightly reformatted for readability):

CITY	DISTANCE_IN_MILES
St Louis	5.36297295
Springfield	78.7997464
Peoria	141.478022
Evansville	158.22422
Springfield	188.508631

[Example C-4](#) extends [Example C-3](#) by limiting the results to cities with a 1990 population over a certain number. It finds the five cities nearest to the interstate highway I170 that have a population greater than 300,000, the 1990 population for each city, and the distance in miles from the highway for each city, ordered by distance in miles.

Example C-4 Finding the Cities Above a Specified Population Nearest to a Highway

```
SELECT /*+ ORDERED NO_INDEX(c pop90_idx) */
       c.city, pop90,
       sdo_nn_distance (1) distance_in_miles
FROM   geod_interstates i,
       geod_cities c
WHERE  i.highway = 'I170'
       AND sdo_nn(c.location, i.geom,
                  'sdo_batch_size=10 unit=mile', 1) = 'TRUE'
       AND c.pop90 > 300000
       AND rownum < 6
ORDER BY distance_in_miles;
```

In [Example C-4](#), because the `ORDERED` optimizer hint is used, it is important to have an index on the `GEOD_INTERSTATES.HIGHWAY` column. In this example, the hint forces the query to locate highway I170 before it tries to find nearest neighbor geometries.

To ensure correct results, disable all nonspatial indexes on columns that come from the same table as the `SDO_NN` search column (`geometry1`). In this example, the `NO_INDEX(c pop90_idx)` optimizer hint disables the nonspatial index on the `POP90` column.

In the `WHERE` clause of this example:

- `sdo_batch_size=10` causes geometries to be returned continually (in distance order, in batches of 10 geometries), to be checked to see if they satisfy the other conditions in the `WHERE` clause.
- `c.pop90 > 300000` restricts the results to rows where the `POP90` column value is greater than 300000.
- `rownum < 6` limits the number of results returned to five.

In [Example C-4](#), `ORDER BY distance_in_miles` orders the results from the `WHERE` clause by distance in miles.

The statement in [Example C-4](#) produces the following output (slightly reformatted for readability):

CITY	POP90	DISTANCE_IN_MILES
St Louis	396685	5.36297295
Kansas City	435146	227.404883
Indianapolis	741952	234.708666
Memphis	610337	244.202072
Chicago	2783726	253.547961

See Also: [Example 5-1](#), "SDO_NN Query with Partitioned Spatial Index" in [Section 5.1.3](#), "Using Partitioned Spatial Indexes"

C.4 SDO_AGGR_UNION Example

If many rows are being aggregated, a single `SDO_AGGR_UNION` aggregate function may take a long time to run. This is because `SDO_AGGR_UNION` aggregates the first two geometries passed in, then aggregates the result to the next geometry, then aggregates the result to the next one, and so on. The reason this will eventually run slowly is that the result will very quickly grow to a geometry with many vertices, and every subsequent aggregation will include this very complex geometry.

For better performance when aggregating many rows, break your aggregation into groupings so that each is always 50 geometries or fewer. [Example C-5](#) shows the following:

- An initial `SELECT` statement to determine how many groupings of 50 (as a power of 2) are needed for the geometries you want to aggregate (in this case, ZIP code geometries in the US states of California, Oregon, and Washington). If there are 5000 such geometries, the `POWER` function result is 128, which you should use for the innermost `GROUP BY` clause in the next `SELECT` statement.
- A `SELECT` statement that uses nested aggregates and `GROUP BY` clauses. For best performance, "skip" power of 2 values in the `GROUP BY` clauses as you go down to 2. This example has clauses using 128, 32, 8, and 2; but it does not have clauses using 64, 16, or 4.

Example C-5 Aggregate Union with Groupings for Many Rows

```
-- Determine how many groupings of 50 are needed. Assume 5000 rows in
-- all. 5000/50 = 100; and 128 is the next higher power of 2.
SELECT POWER(2, CEIL( LOG(2, COUNT(*)/50)))
FROM ZIP_CODES z
WHERE z.state_code IN ('CA', 'OR', 'WA');

-- Perform the aggregate union operation, using 128 in the
-- innermost GROUP BY clause.
SELECT sdo_aggr_union(sdoaggrtype(aggr_geom,0.5)) aggr_geom
FROM
  (SELECT sdo_aggr_union(sdoaggrtype(aggr_geom,0.5)) aggr_geom
   FROM
     (SELECT sdo_aggr_union(sdoaggrtype(aggr_geom,0.5)) aggr_geom
      FROM
        (SELECT sdo_aggr_union(sdoaggrtype(aggr_geom,0.5)) aggr_geom
         FROM
           (SELECT sdo_aggr_union(mdsys.sdoaggrtype(geom,0.5)) aggr_geom
            FROM ZIP_CODES z
```

```
WHERE z.state_code IN ('CA', 'OR', 'WA')
GROUP BY mod(rownum,128))
GROUP BY mod (rownum, 32))
GROUP BY mod (rownum, 8))
GROUP BY mod (rownum, 2)
);
```

Loading ESRI Shapefiles into Spatial

The Java Shapefile converter transforms an ESRI Shapefile into an Oracle Database table for use with Oracle Spatial and Locator. The Shapefile converter uses the Oracle Spatial Java-based Shapefile Adapter `ShapefileJGeom` and `SampleShapefileToJGeomFeature` classes to load a Shapefile directly into a database table, with the Oracle-equivalent `.dbf` data types for the attribute columns and the `SDO_GEOMETRY` data type for the geometry column.

To load a Shapefile into the database, use the converter as described in this appendix. (You can also use the Adapter class to create your own applications and interfaces that transform Shapefiles to `SDO_GEOMETRY` or `JGeometry` data types; however, doing this is beyond the scope of this manual. For information about Shapefile-related classes, see *Oracle Spatial Java API Reference*).

To use the Shapefile converter, you must have the following:

- The following Oracle utilities and JDBC libraries: `ojdbc14.jar` or `ojdbc5.jar`, `sdoutl.jar`, and `sdoapi.jar`
- One or more ESRI Shapefiles (`.shp`, `.shx`, and `.dbf` files) to be converted

D.1 Usage of the Shapefile Converter

The following is the syntax for the Shapefile converter. (Enter the command all on a single line.)

```
> java -cp [ORACLE_HOME]/jdbc/lib/ojdbc5.jar:[ORACLE_
HOME]/md/jlib/sdoutl.jar:[ORACLE_HOME]/md/jlib/sdoapi.jar
oracle.spatial.util.SampleShapefileToJGeomFeature -h db_host -p db_port -s db_sid
-u db_username -d db_password -t db_table -f shapefile_name [-i table_id_column_
name] [-r srid] [-g db_geometry_column] [-x max_x,min_x] [-y max_y,min_y] [-o
tolerance]
```

Parameters

- h: Host machine with an existing Oracle database
- p: Port on the host machine (for example, 1521)
- s: SID (database name) on the host machine
- u: Database user
- d: Password for the database use
- t: Table name for the converted Shapefile
- f: File name of an input Shapefile (without extension)

- i: Column name for unique numeric ID, if required
- r: Valid Oracle SRID for coordinate system; use 0 if unknown
- g: Preferred SDO_GEOMETRY column name
- x: Bounds for the X dimension; use -180,180 if unknown
- y: Bounds for the Y dimension; use -90,90 if unknown
- o: Load tolerance fields (x and y) in metadata; if not specified, tolerance fields are 0.05
- a: Append Shapefile data to an existing table
- n: Start ID for column specified in -i parameter
- c: Commit interval; by default, commits occur every 1000 conversions and at the end
- v: Println interval; by default, a display every 10 conversions

D.2 Examples of the Shapefile Converter

The following examples show the use of the Shapefile converter to transform a file named `shapes` to a table named `shapes` containing an `SDO_GEOMETRY` column named `geom`. The SRID for the Longitude/Latitude (WGS 84) coordinate system is used (8307).

Linux Example

```
> setenv classpath $ORACLE_HOME/jdbc/lib/ojdbc5.jar:$ORACLE_
HOME/md/jlib/sdoutl.jar:$ORACLE_HOME/md/jlib/sdoapi.jar
> java -cp $classpath oracle.spatial.util.SampleShapefileToJGeomFeature -h gis01 -p
1521 -s orcl -u scott -d <password-for-scott> -t states -f states -r 8307 -g geom
```

Windows Example

```
> java -classpath %ORACLE_HOME%\jdbc\lib\ojdbc5.jar;%ORACLE_
HOME%\md\jlib\sdoutl.jar;%ORACLE_HOME%\md\jlib\sdoapi.jar
oracle.spatial.util.SampleShapefileToJGeomFeature -h gis01 -p 1521 -s orcl -u
scott -d <password-for-scott> -t states -f states -r 8307 -g geom
```

Glossary

area

An extent or region of dimensional space.

attribute

Descriptive information characterizing a geographical feature such as a point, line, or area.

attribute data

Nondimensional data that provides additional descriptive information about multidimensional data, for example, a class or feature such as a bridge or a road.

batch geocoding

An operation that simultaneously geocodes many records from one table. *See also* [geocoding](#).

boundary

1. The lower or upper extent of the range of a dimension, expressed by a numeric value.
2. The line representing the outline of a polygon.

Cartesian coordinate system

A coordinate system in which the location of a point in n -dimensional space is defined by distances from the point to the reference plane. Distances are measured parallel to the planes intersecting a given reference plane. *See also* [coordinate system](#).

colocation

The presence of two or more spatial objects at the same location or at significantly close distances from each other.

contain

A geometric relationship where one object encompasses another and the inner object does not touch any boundaries of the outer. The outer object *contains* the inner object. *See also* [inside](#).

convex hull

A simple convex polygon that completely encloses the associated geometry object.

coordinate

A set of values uniquely defining a point in an n -dimensional coordinate system.

coordinate reference system

Synonymous with [coordinate system](#) in Oracle Spatial documentation. The term *coordinate reference system* is used extensively by the European Petroleum Survey Group (EPSG).

coordinate system

A reference system for the unique definition for the location of a point in *n*-dimensional space. Also called a spatial reference system. *See also* [Cartesian coordinate system](#), [geodetic coordinates](#), [projected coordinates](#), and [local coordinates](#).

cover

A geometric relationship in which one object encompasses another and the inner object touches the boundary of the outer object in one or more places.

data dictionary

A repository of information about data. A data dictionary stores relational information on all objects in a database.

datum transformation

See [transformation](#).

dimensional data

Data that has one or more dimensional components and is described by multiple values.

direction

The direction of an LRS geometric segment is indicated from the start point of the geometric segment to the end point. Measures of points on a geometric segment always increase along the direction of the geometric segment.

disjoint

A geometric relationship where two objects do not interact in any way. Two *disjoint* objects do not share any element or piece of their geometry.

element

A basic building block (point, line string, or polygon) of a geometry.

equal

A geometric relationship in which two objects are considered to represent the same geometric figure. The two objects must be composed of the same number of points; however, the ordering of the points defining geometries of the two objects may differ (clockwise or counterclockwise).

extent

A rectangle bounding a map, the size of which is determined by the minimum and maximum map coordinates.

feature

An object with a distinct set of characteristics in a spatial database.

geocoding

The process of converting tables of address data into standardized address, location, and possibly other data. *See also* [batch geocoding](#).

geodetic coordinates

Angular coordinates (longitude and latitude) closely related to spherical polar coordinates and defined relative to a particular Earth geodetic datum. Also referred to as geographic coordinates.

geodetic datum

A means of representing the figure of the Earth, usually as an oblate ellipsoid of revolution, that approximates the surface of the Earth locally or globally, and is the reference for the system of geodetic coordinates.

geographic coordinates

See [geodetic coordinates](#).

geographic information system (GIS)

A computerized database management system used for the capture, conversion, storage, retrieval, analysis, and display of spatial data.

geographically referenced data

See [spatiotemporal data](#).

geometric segment (LRS segment)

An LRS element that contains start and end measures for its start and end points, and that can contain measures for other points on the segment.

geometry

The geometric representation of the shape of a spatial feature in some coordinate space. A geometry is an ordered sequence of vertices that are connected by straight line segments or circular arcs.

georeferenced data

See [spatiotemporal data](#).

GIS

See [geographic information system \(GIS\)](#).

grid

A data structure composed of points located at the nodes of an imaginary grid. The spacing of the nodes is constant in both the horizontal and vertical directions.

hole

A subelement of a polygon that negates a section of its interior. For example, consider a polygon representing a map of buildable land with an inner polygon (a hole) representing where a lake is located.

homogeneous

Spatial data of one feature type such as points, lines, or regions.

hyperspatial data

In mathematics, any space having more than the three standard X, Y, and Z dimensions. Sometimes referred to as multidimensional data.

index

A database object that is used for fast and efficient access to stored information.

inside

A geometric relationship where one object is surrounded by a larger object and the inner object does not touch the boundary of the outer. The smaller object is *inside* the larger. *See also* [contain](#).

key

A field in a database used to obtain access to stored information.

latitude

North/south position of a point on the Earth defined as the angle between the normal to the Earth's surface at that point and the plane of the equator.

layer

A collection of geometries having the same attribute set and stored in a geometry column.

line

A geometric object represented by a series of points, or inferred as existing between two coordinate points.

line string

One or more pairs of points that define a line segment. *See also* [multiline string](#).

linear feature

Any spatial object that can be treated as a logical set of linear segments.

local coordinates

Cartesian coordinates in a non-Earth (non-georeferenced) coordinate system.

longitude

East/west position of a point on the Earth defined as the angle between the plane of a reference meridian and the plane of a meridian passing through an arbitrary point.

LRS point

A point with linear measure information along a geometric segment. *See also* [geometric segment \(LRS segment\)](#).

measure

The linear distance (in the LRS measure dimension) to a point measured from the start point (for increasing values) or end point (for decreasing values) of the geometric segment.

measure range

The measure values at the start and end of a geometric segment.

minimum bounding rectangle (MBR)

A single rectangle that minimally encloses a geometry or a collection of geometries.

multidimensional data

See [hyperspatial data](#).

multiline string

A geometry object made up of nonconnected line string elements (for example, a street with a gap caused by a city park, such as Sixth Avenue in New York City with Central Park as the gap). *See also* [line string](#).

multipolygon

A polygon collection geometry in which rings must be grouped by polygon, and the first ring of each polygon must be the exterior ring.

neighborhood influence

See [spatial correlation](#).

offset

The perpendicular distance between a point along a geometric segment and the geometric segment. Offsets are positive if the points are on the left side along the segment direction and are negative if they are on the right side. Points are on a geometric segment if their offsets to the segment are zero.

oriented point

A special type of point geometry that includes coordinates representing the locations of the point and a virtual end point, to indicate an orientation vector that can be used for rotating a symbol at the point or extending a label from the point

polygon

A class of spatial objects having a nonzero area and perimeter, and representing a closed boundary region of uniform characteristics.

primary filter

The operation that permits fast selection of candidate records to pass along to the secondary filter. The primary filter compares geometry approximations to reduce computation complexity and is considered a lower-cost filter. Because the primary filter compares geometric approximations, it returns a superset of the exact result set. *See also* [secondary filter](#) and [two-tier query model](#).

projected coordinates

Planar Cartesian coordinates that result from performing a mathematical mapping from a point on the Earth's surface to a plane. There are many such mathematical mappings, each used for a particular purpose.

projection

The point on the LRS geometric segment with the minimum distance to the specified point.

proximity

A measure of distance between objects.

query

A set of conditions or questions that form the basis for the retrieval of information from a database.

query window

Area within which the retrieval of spatial information and related attributes is performed.

RDBMS

See [Relational Database Management System \(RDBMS\)](#).

recursion

A process, function, or routine that executes continuously until a specified condition is met.

region

An extent or area of multidimensional space.

Relational Database Management System (RDBMS)

A computer program designed to store and retrieve shared data. In a relational system, data is stored in tables consisting of one or more rows, each containing the same set of columns. Oracle Database is an object-relational database management system. Other types of database systems are called hierarchical or network database systems.

resolution

The number of subdivision levels of data.

scale

The ratio of the distance on a map, photograph, or image to the corresponding image on the ground, all expressed in the same units.

secondary filter

The operation that applies exact computations to geometries that result from the primary filter. The secondary filter yields an accurate answer to a spatial query. The secondary filter operation is computationally expensive, but it is only applied to the primary filter results, not the entire data set. See also [primary filter](#) and [two-tier query model](#).

shape points

Points that are specified when an LRS segment is constructed, and that are assigned measure information.

sort

The operation of arranging a set of items according to a key that determines the sequence and precedence of items.

spatial

A generic term used to reference the mathematical concept of n -dimensional data.

spatial binning

The process of discretizing the location values into a small number of groups associated with geographical areas. Also referred to as *spatial discretization*.

spatial correlation

The phenomenon of the location of a specific object in an area affecting some nonspatial attribute of the object. Also referred to as *neighborhood influence*.

spatial data

Data that is referenced by its location in n -dimensional space. The position of spatial data is described by multiple values. See also [hyperspatial data](#).

spatial data model

A model of how objects are located on a spatial context.

spatial data structures

A class of data structures designed to store spatial information and facilitate its manipulation.

spatial database

A database containing information indexed by location.

spatial discretization

See [spatial binning](#).

spatial join

A query in which each of the geometries in one layer is compared with each of the geometries in the other layer. Comparable to a spatial cross product.

spatial query

A query that includes criteria for which selected features must meet location conditions.

spatial reference system

See [coordinate system](#).

spatiotemporal data

Data that contains time or location (or both) components as one of its dimensions, also referred to as geographically referenced data or georeferenced data.

SQL*Loader

A utility to load formatted data into spatial tables.

tolerance

The distance that two points can be apart and still be considered the same (for example, to accommodate rounding errors). The tolerance value must be a positive number greater than zero. The significance of the value depends on whether or not the spatial data is associated with a geodetic coordinate system.

touch

A geometric relationship where two objects share a common point on their boundaries, but their interiors do not intersect.

transformation

The conversion of coordinates from one coordinate system to another coordinate system. If the coordinate system is georeferenced, transformation can involve datum transformation: the conversion of geodetic coordinates from one geodetic datum to another geodetic datum, usually involving changes in the shape, orientation, and center position of the reference ellipsoid.

two-tier query model

The query model used by Spatial to resolve spatial queries and spatial joins. Two distinct filtering operations (primary and secondary) are performed to resolve queries. The output of both operations yields the exact result set. See also [primary filter](#) and [secondary filter](#).

Numerics

0

type 0 (zero) element, 2-29

3D

formats of LRS functions, 7-7

not supported with geodetic data, 6-69

spatial objects, 1-15

solids, 1-18

surfaces, 1-17

A

ADD_PREFERENCE_FOR_OP procedure, 21-4

addresses

representing for geocoding, 11-1

affine transformation

of input geometry, 32-4

AFFINETRANSFORMS procedure, 32-4

aggregate functions

description, 1-13

reference information, 20-1

SDO_AGGR_CENTROID, 20-2

SDO_AGGR_CONCAT_LINES, 20-3

SDO_AGGR_CONVEXHULL, 20-5

SDO_AGGR_LRS_CONCAT, 20-6

SDO_AGGR_MBR, 20-8

SDO_AGGR_SET_UNION, 20-9

SDO_AGGR_UNION, 20-11

SDOAGGRTYPE object type, 1-14

AGGREGATES_FOR_GEOMETRY function, 29-3

AGGREGATES_FOR_LAYER function, 29-5

aliases, 6-20

ALL_ANNOTATION_TEXT_METADATA

view, 3-10

ALL_SDO_GEOM_METADATA view, 2-44

ALL_SDO_INDEX_INFO view, 2-46

ALL_SDO_INDEX_METADATA view, 2-47

alpha shape

SDO_ALPHA_SHAPE function, 24-7

ALTER INDEX statement, 18-2

REBUILD clause, 18-4

RENAME TO clause, 18-7

angle units, 6-46

annotation text, 3-8

ANYINTERACT

SDO_ANYINTERACT operator, 19-3

topological relationship, 1-12

APPEND function, 32-10

application size (hardware) requirements, 1-27

application user management

identity propagation option, 17-2

arc

densifying, 24-9

not supported with geodetic data or for

transformations, 6-6

area, 24-11

area units, 6-47

average minimum bounding rectangle, 31-2

AVERAGE_MBR procedure, 31-2

B

batch route requests, 13-23

DTD, 13-22

example, 13-19

batch route responses

DTD, 13-24

example, 13-19

batch_route_request element, 13-23

bearing

point at, 32-50

tilt for points, 32-11

BEARING_TILT_FOR_POINTS procedure, 32-11

BIN_GEOMETRY function, 29-7

BIN_LAYER procedure, 29-9

binning

spatial, 8-3

bins

assigning, 29-9

computing, 29-7

tiled, 29-21

boundary

of area, 1-10

of line string, 1-11

of multiline string, 1-11

of polygon, 1-11

bounding rectangle

minimum, 31-7

box

optimized, 2-11

British Grid Transformation

- OSTN02/OSGM02, 6-67
- buffer area, 24-13
- bulk loading of spatial data, 4-1
- business directory (YP)
 - data requirements and providers, 12-1
 - data structures for, 12-2
 - OpenLS service support and examples, 14-8
 - support in Spatial, 12-1

C

- C language
 - examples (using OCI), 1-28
- Cartesian coordinates, 1-5, 6-2
- cartographic text (annotation text), 3-8
- center of gravity (centroid), 24-16
- centroid
 - SDO_AGGR_CENTROID aggregate function, 20-2
 - SDO_CENTROID function, 24-16
- circle
 - creating polygon approximating, 32-13
 - not supported with geodetic data or for projections, 6-6
 - type, 2-10
- CIRCLE_POLYGON function, 32-13
- CLIP_GEOM_SEGMENT function, 25-5
- CLIP_PC function, 28-2
- CLIP_TIN procedure, 30-2
- clipping
 - geometric segment, 7-9
- closest points
 - SDO_CLOSEST_POINTS procedure, 24-18
- COLOCATED_REFERENCE_FEATURES procedure, 29-11
- colocation mining, 8-4
- column name
 - restrictions on spatial column names, 2-45
- COLUMN_NAME (in USER_SDO_GEOM_METADATA), 2-45
- compatibility, A-1
- complex examples
 - queries, C-1
- compound element, 2-8
- compound line string, 2-10, 2-23
- compound polygon, 2-10
- CONCAT_LINES function, 32-15
- CONCATENATE_GEOM_SEGMENTS function, 25-7
- concatenating
 - geometric segments, 7-10
 - line or multiline geometries, 20-3
 - LRS geometries, 7-11, 20-6
- concave hull
 - SDO_CONCAVEHULL function, 24-20
 - SDO_CONCAVEHULL_BOUNDARY function, 24-22
- CONNECTED_GEOM_SEGMENTS function, 25-10
- consistency
 - checking for valid geometry types, 24-49

- constraining data to a geometry type, 5-2
- constructors
 - SDO_GEOMETRY object type, 2-13
- CONTAINS
 - SDO_CONTAINS operator, 19-5
 - topological relationship, 1-12
- CONVERSION_FACTOR column
 - in SDO_ANGLE_UNITS table, 6-46
 - in SDO_AREA_UNITS table, 6-47
 - in SDO_DIST_UNITS table, 6-49
- CONVERT_NADCON_TO_XML procedure, 21-6
- CONVERT_NTV2_TO_XML procedure, 21-8
- CONVERT_TO_LRS_DIM_ARRAY function, 25-12
- CONVERT_TO_LRS_GEOM function, 25-14
- CONVERT_TO_LRS_LAYER function, 25-16
- CONVERT_TO_STD_DIM_ARRAY function, 25-18
- CONVERT_TO_STD_GEOM function, 25-19
- CONVERT_TO_STD_LAYER function, 25-20
- CONVERT_UNIT function, 32-17
- CONVERT_XML_TO_NADCON procedure, 21-10
- CONVERT_XML_TO_NTV2 procedure, 21-12
- converting
 - geometric segments
 - overview, 7-14
 - subprograms for, 25-3
- convex hull
 - SDO_AGGR_CONVEXHULL aggregate function, 20-5
 - SDO_CONVEXHULL function, 24-24
- coordinate dimension
 - ST_CoordDim method, 2-12
- coordinate reference systems
 - See coordinate systems
- coordinate systems, 1-5
 - conceptual and usage information, 6-1
 - data structures supplied by Oracle, 6-19
 - example, 6-72
 - local, 6-7
 - subprogram reference information, 21-1
 - unit of measurement support, 2-49
 - user-defined, 6-52
- coordinates
 - Cartesian, 1-5, 6-2
 - geodetic, 1-5, 6-2
 - geographic, 1-5, 6-2
 - local, 1-6, 6-2
 - projected, 1-5, 6-2
- COVEREDBY
 - SDO_COVEREDBY operator, 19-7
 - topological relationship, 1-12
- COVERS
 - SDO_COVERS operator, 19-9
 - topological relationship, 1-12
- CPU requirements for applications using Spatial, 1-27
- CREATE INDEX statement, 18-8
- CREATE_CONCATENATED_OP procedure, 21-14
- CREATE_OBVIOUS_EPSG_RULES procedure, 21-15
- CREATE_PC procedure, 28-4

- CREATE_PREF_CONCATENATED_OP
 - procedure, 21-16
- CREATE_PROFILE_TABLES procedure, 23-2
- CREATE_TIN procedure, 30-4
- createXMLTableIndex method, 15-13, 16-15
- creating
 - geometric segments
 - subprograms for, 25-1
- cross-schema index creation, 5-2
- CS_SRS table, 6-42
- current release
 - upgrading spatial data to, 26-2
- cutoff_distance attribute
 - of batch route request, 13-23

D

- data mining
 - spatial
 - colocation mining, 8-4
 - conceptual and usage information, 8-1
 - function reference information, 29-1
- data model, 1-4
 - LRS, 7-6
- data types
 - geocoding, 11-5
 - spatial, 2-1
- database links
 - not supported if spatial index is defined on the table, 5-7
- data-sources.xml file, 10-2
- datum
 - geodetic, 1-5, 6-2
 - MDSYS.SDO_DATUMS_OLD_FORMAT
 - table, 6-47
 - MDSYS.SDO_DATUMS_OLD_SNAPSHOT
 - table, 6-47
 - transformation, 6-2
- dblink
 - not supported if spatial index is defined on the table, 5-7
- DEFINE_GEOM_SEGMENT procedure, 25-22
- defining
 - geometric segment, 7-8
- DELETE_ALL_EPSG_RULES procedure, 21-18
- DELETE_OP procedure, 21-19
- DeleteCapabilitiesInfo procedure, 22-2
- deleteDomainInfo method, 16-15
- DeleteDomainInfo procedure, 22-3
- DeletePluginMap procedure, 22-4
- deleteRecordViewMap method, 16-16
- DeleteRecordViewMap procedure, 22-5
- demo files
 - Spatial Web services, 10-6
- densification of arcs, 24-9
- detailed route geometry
 - in route request, 13-17
- DETERMINE_CHAIN function, 21-20
- DETERMINE_DEFAULT_CHAIN function, 21-22
- difference

- SDO_GEOM.SDO_DIFFERENCE function, 24-26
- dimension (in SDO_GTYPE), 2-5, 2-6
 - Get_Dims method, 2-12
 - Get_LRS_Dim method, 2-12
- DIMINFO (in USER_SDO_GEOM_METADATA), 2-45
- direction of geometric segment, 7-2
 - concatenation result, 7-10
- disableVersioning method, 16-16
- discretization (binning)
 - spatial, 8-3
 - See also* bins
- DISJOINT
 - topological relationship, 1-11
- disk storage requirements for applications using Spatial, 1-27
- distance
 - SDO_NN_DISTANCE ancillary operator, 19-28
 - WITHIN_DISTANCE function, 24-56
- distance units, 6-49
- distance_unit attribute
 - of route request, 13-18
- distributed transactions
 - requirements to ensure spatial index consistency, 5-6
- document-based feature types (WFS), 15-2
- domain information (CSW)
 - deleting, 16-15
- domains (CSW)
 - setting information, 16-27
- Douglas-Peucker algorithm for geometry simplification, 32-59
- downgrading
 - Oracle Spatial to the previous Oracle Database release, A-1
- driving directions
 - in route request, 13-17
- driving_directions_detail attribute
 - of route request, 13-18
- DROP INDEX statement, 18-12
- DROP_DEPENDENCIES procedure, 28-6, 30-6
- DROP_WORK_TABLES procedure, 32-18
- dropFeatureType method, 15-13
- DropFeatureType procedure, 34-3
- DropFeatureTypes procedure, 34-4
- dropRecordType method, 16-16
- dropXMLTableIndex method, 15-14, 16-17
- duplicate vertices
 - removing, 32-56
- dynamic query window, 5-8
- DYNAMIC_SEGMENT function, 25-25

E

- .ear file
 - configuring for Spatial Web services, 17-4
- edge ID values
 - for subroutes in route request, 13-17
 - in route request, 13-17
- EDGE table

- routing engine use of, 13-24
- editing
 - geometric segments
 - subprograms for, 25-1
- ELEM_INFO (SDO_ELEM_INFO attribute), 2-7
- elements, 1-4
 - extracting from a geometry, 32-21, 32-24
 - returning number of elements in a
 - geometry, 32-43
 - returning number of vertices in a geometry, 32-44
- ellipse
 - creating polygon approximating, 32-19
- ELLIPSE_POLYGON function, 32-19
- ellipsoidal height, 6-3, 6-10
- ellipsoids
 - MDSYS.SDO_ELLIPSOIDS_OLD_FORMAT
 - table, 6-49
 - MDSYS.SDO_ELLIPSOIDS_OLD_SNAPSHOT
 - table, 6-49
- embedded SDO_GEOMETRY object in user-defined
 - type, 9-1
- EnableDBTxns procedure, 33-2
- enableVersioning method, 16-17
- end location for route, 13-16
- entity-relationship (E-R) diagram
 - EPSG tables, 6-37
- EPSG
 - entity-relationship (E-R) diagram, 6-8
 - mapping of table names to Oracle Spatial
 - names, 6-37
 - mapping Oracle SRID to, 21-37
 - mapping SRID to Oracle SRID, 21-36
 - model and use by Spatial, 6-8
 - version number of dataset used by Spatial, 21-33
- EQUAL
 - SDO_EQUAL operator, 19-11
 - topological relationship, 1-12
- E-R (entity-relationship diagram)
 - EPSG tables, 6-37
- error messages
 - geocoding, 11-4
 - Spatial, 1-27
- ESRI Shapefiles
 - loading into Spatial, D-1
- ESTIMATE_RTREE_INDEX_SIZE function, 31-4
- ETYPE (SDO_ETYPE value), 2-8, 2-9
- European Petroleum Survey Group
 - See EPSG
- examples
 - batch route request and response, 13-19
 - C, 1-28
 - complex queries, C-1
 - coordinate systems, 6-72
 - creating, indexing, and querying spatial data, 2-1
 - directory for Spatial examples, 1-28
 - linear referencing system (LRS), 7-15
 - many geometry types (creating), 2-20
 - OCI (Oracle Call Interface), 1-28
 - PL/SQL, 1-28
 - route request and response, 13-9

- route request with previously geocoded
 - locations, 13-13
- route response with previously geocoded
 - locations, 13-14
- SQL, 1-28
- exchanging partitions including indexes, 5-5
- Export utility
 - with spatial indexes and data, 5-5
- EXTENT_OF function, 31-7
- exterior polygon rings, 2-8, 2-21, 2-22
- exterior solids, 2-8
- EXTRACT function, 32-21
- EXTRACT_ALL function, 32-24
- EXTRACT3D function, 32-28
- extractSDO function, 16-3
- EXTRUDE function, 32-30
- extrusion
 - creating, 32-30

F

- feature types
 - dropping, 15-13
 - granting access to a user, 15-14
 - publishing, 15-15
 - revoking access from a user, 15-23
- features
 - linear, 7-5
- FILTER
 - SDO_FILTER operator, 19-13
- FILTER mask value for SDO_JOIN, 19-19
- FIND_GEOG_CRS function, 21-23
- FIND_LRS_DIM_POS function, 25-27
- FIND_MEASURE function, 25-28
- FIND_OFFSET function, 25-30
- FIND_PROJ_CRS function, 21-25
- FIND_SRID procedure, 21-27
- formatted addresses, 11-1
- FROM_GML311GEOMETRY function, 32-33
- FROM_GMLGEOMETRY function, 32-35
- FROM_KMLGEOMETRY function, 32-37
- FROM_OGC_SIMPLEFEATURE_SRS
 - function, 21-31
- FROM_USNG function, 21-32
- FROM_WKBGEOMETRY function, 32-39
- FROM_WKTGEOMETRY function, 32-41
- frustums, 1-18
- function-based indexes
 - with SDO_GEOMETRY objects, 9-3
- functions
 - spatial aggregate, 20-1
 - supported by approximations with geodetic
 - data, 6-70

G

- GC_ADDRESS_POINT_<suffix> table, 11-11
- GC_AREA_<suffix> table, 11-12
- GC_COUNTRY_PROFILE table, 11-14
- GC_INTERSECTION_<suffix> table, 11-15

GC_PARSER_PROFILEAFS table, 11-19
 GC_PARSER_PROFILES table, 11-16
 GC_POI_<suffix> table, 11-22
 GC_POSTAL_CODE_<suffix> table, 11-23
 GC_ROAD_<suffix> table, 11-24
 GC_ROAD_SEGMENT_<suffix> table, 11-26
 GenCollectionProcs procedure, 34-5
 GEOCODE function, 23-3
 GEOCODE_ADDR function, 23-4
 GEOCODE_ADDR_ALL function, 23-6
 GEOCODE_ALL function, 23-8
 GEOCODE_AS_GEOMETRY function, 23-10
 geocoding, 1-24
 concepts, 11-1
 data requirements, 11-8
 data types for, 11-5
 error messages, 11-4
 from a place name, 11-9
 indexes required on tables for geocoding, 11-28
 match codes, 11-3
 match modes, 11-2
 reverse, 23-11
 subprogram reference information, 23-1
 usage information, 11-1
 geocoding requests
 DTD, 11-33
 geocoding responses
 DTD, 11-35
 geodetic coordinates, 1-5, 6-2
 arcs and circles not supported, 6-6
 functions supported by approximations, 6-70
 support for, 6-2
 geodetic datum, 1-5, 6-2
 geodetic MBRs, 6-5
 geographic coordinates
 See geodetic coordinates
 geography markup language (GML)
 converting geometry to, 32-62, 32-67
 GEOM_SEGMENT_END_MEASURE
 function, 25-32
 GEOM_SEGMENT_END_PT function, 25-33
 GEOM_SEGMENT_LENGTH function, 25-34
 GEOM_SEGMENT_START_MEASURE
 function, 25-35
 GEOM_SEGMENT_START_PT function, 25-36
 geometric segment
 clipping, 7-9
 concatenating, 7-10
 aggregate, 7-11, 20-6
 converting (overview), 7-14
 converting (subprograms for), 25-3
 creating (subprograms for), 25-1
 defining, 7-8
 definition of, 7-1
 direction, 7-2
 direction with concatenation, 7-10
 editing (subprograms for), 25-1
 locating point on, 7-12
 offsetting, 7-12
 projecting point onto, 7-13
 querying (subprograms for), 25-2
 redefining, 7-8
 scaling, 7-11
 splitting, 7-9
 geometry subprograms
 reference information, 24-1
 geometry types, 1-3
 constraining data to, 5-2
 Get_GType method, 2-12
 SDO_GTYPE, 2-5
 GeoRaster
 checks and actions after upgrade, A-1
 gerRecordTypeId method, 16-17
 Get_Dims method, 2-12
 GET_EPSG_DATA_VERSION function, 21-33
 Get_GType method, 2-12
 Get_LRS_Dim method, 2-12
 GET_MEASURE function, 25-37
 GET_NEXT_SHAPE_PT function, 25-38
 GET_NEXT_SHAPE_PT_MEASURE function, 25-40
 GET_PREV_SHAPE_PT function, 25-42
 GET_PREV_SHAPE_PT_MEASURE function, 25-44
 GET_PT_IDS function, 28-7
 Get_WKB method, 2-12
 Get_WKT method, 2-12
 GetFeatureTypeId function, 34-6
 getIsXMLTableIndexCreated method, 15-14, 16-17
 GETNUMELEM function, 32-43
 GETNUMVERTICES function, 32-44
 GetRecordTypeId function, 22-6
 GETVERTICES function, 32-45
 GML (geography markup language)
 converting geometry to, 32-62, 32-67
 Google Maps
 considerations for using with Spatial
 applications, 6-71
 grantFeatureTypeToUser method, 15-14
 GrantFeatureTypeToUser procedure, 34-7
 grantMDAccessToUser method, 15-15, 16-18
 GrantMDAccessToUser procedure, 34-8
 grantRecordTypeToUser method, 16-18
 gravity-related height, 6-10
 GTYPE (SDO_GTYPE attribute), 2-5
 constraining data to a geometry type, 5-2
 Get_Dims method, 2-12
 Get_GType method, 2-12
 GET_LRS_Dim method, 2-12

H

hardware requirements for applications using
 Spatial, 1-27
 height
 ellipsoidal, 6-10
 ellipsoidal and non-ellipsoidal, 6-3
 gravity-related, 6-10
 hierarchical driving directions
 in route request, 13-17

I

- id attribute
 - of route request, 13-16
- identity propagation
 - application user management, 17-2
 - proxy authentication, 17-2
 - single application user, 17-2
 - Spatial Web services, 17-2
- Import utility
 - with spatial indexes and data, 5-5
- index
 - distributed transactions and spatial index consistency, 5-6
- indexes
 - creating, 5-1
 - cross-schema, 5-2
 - parallel execution, 18-9
 - description of Spatial indexing, 1-9
 - extending spatial indexing capabilities, 9-1
 - function-based with SDO_GEOMETRY objects, 9-3
 - partitioned, 5-2
 - exchanging partitions including indexes, 5-5
 - rebuilding, 18-4
 - parallel execution, 18-3, 18-5
 - R-tree
 - description, 1-9
 - requirements before creating, 5-7
 - size (R-tree), 31-4
- index-organized tables
 - cannot create spatial index on, 2-45, 18-10
- INIT function, 28-8, 30-7
- INITIALIZE_INDEXES_FOR_TTS procedure, 32-47
- input_location element, 13-18
- InsertCapabilitiesInfo procedure, 22-7, 34-9
- InsertDomainInfo procedure, 22-8
- InsertFtDataUpdated procedure, 34-10
- InsertFtMDUpdated procedure, 34-11
- inserting spatial data
 - PL/SQL, 4-3
- InsertPluginMap procedure, 22-9
- InsertRecordViewMap procedure, 22-10
- InsertRtDataUpdated procedure, 22-12
- InsertRtMDUpdated procedure, 22-13
- INSIDE
 - SDO_INSIDE operator, 19-16
 - topological relationship, 1-12
- installation, A-1
 - Oracle Multimedia requirement for Locator, B-1
- INTERPRETATION (SDO_INTERPRETATION value), 2-8
- interaction
 - ANYINTERACT, 1-12
- interior
 - of an area, 1-10
- interior polygon rings, 2-8, 2-21, 2-22
- interior solids, 2-8
- INTERIOR_POINT function, 32-49
- International Organization for Standardization (ISO)
 - compliance of Spatial with standards, 1-26

- intersection, 24-30, 25-53
- intersections
 - GC_INTERSECTION_<suffix> table, 11-15
- inverse flattening, 6-34, 6-50
- IS_GEOM_SEGMENT_DEFINED function, 25-46
- IS_MEASURE_DECREASING function, 25-47
- IS_MEASURE_INCREASING function, 25-48
- IS_SHAPE_PT_MEASURE function, 25-49
- ISO (International Organization for Standardization)
 - compliance of Spatial with standards, 1-26

J

- Java application programming interface (API) for Spatial, 1-24
 - WFS administration, 15-13, 16-15
- join
 - SDO_JOIN operator, 19-18

K

- Keyhole Markup Language (KML)
 - FROM_KMLGEOMETRY function, 32-37
 - TO_KMLGEOMETRY function, 32-73
- KML
 - FROM_KMLGEOMETRY function, 32-37
 - TO_KMLGEOMETRY function, 32-73

L

- language attribute
 - of route request, 13-18
- layer, 1-5
 - transforming, 21-44
 - validating with context, 24-53
- layer_gtype
 - constraining data to a geometry type, 5-2
- length
 - SDO_LENGTH function, 24-32
- line
 - converting polygon to, 32-52
 - data, 1-5
 - length, 24-32
- line string
 - boundary of, 1-11
 - compound, 2-10, 2-23
 - reversing, 32-58
 - self-crossing, 1-4
- linear features, 7-5
- linear measure, 7-3
- linear referencing system (LRS)
 - 3D formats of functions, 7-7
 - not supported with geodetic data, 6-69
 - conceptual and usage information, 7-1
 - data model, 7-6
 - example, 7-15
 - Get_LRS_Dim method, 2-12
 - limiting indexing to X and Y dimensions, 7-7
 - LRS points, 7-5
 - segments, 7-1
 - subprogram reference information, 25-1

- tolerance values with LRS functions, 7-15
- loading spatial data, 4-1
- local coordinate systems, 6-7
- local coordinates, 1-6, 6-2
- LOCAL partitioning
 - spatial indexes, 5-2
- LOCATE_PT function, 25-51
- location for route segment, 13-16
- location prospecting, 8-5
- Locator, B-1
 - manually installing, B-4
- LRS
 - See* linear referencing system (LRS)
- LRS points, 7-5
- LRS_INTERSECTION function, 25-53

M

- MAKE_3D function, 21-34, 21-35
- MakeOpenLSClobRequest function, 27-2
- MakeOpenLSRequest function, 27-4
- map projections
 - MDSYS.SDO_PROJECTIONS_OLD_FORMAT table, 6-50
 - MDSYS.SDO_PROJECTIONS_OLD_SNAPSHOT table, 6-50
- MAP_EPSG_SRID_TO_ORACLE function, 21-36
- MAP_ORACLE_SRID_TO_EPSG function, 21-37
- match codes, 11-3
- match modes, 11-2
- match vector (MatchVector attribute)
 - geocoding, 11-4
- max-corner values
 - for three-dimensional rectangle, 1-19
- MBR
 - See* minimum bounding rectangle (MBR)
- MDDATA account and schema, 1-25
- mddins.sql script, B-4
- mdinst.sql script, B-4
- MDSYS schema, 1-2
- MDSYS.CS_SRS table, 6-42
- MDSYS.MOVE_SDO procedure, 1-27
- MDSYS.SDO_ANGLE_UNITS table, 6-46
- MDSYS.SDO_AREA_UNITS view, 6-47
- MDSYS.SDO_CS package, 21-1
- MDSYS.SDO_DATUMS_OLD_FORMAT table, 6-47
- MDSYS.SDO_DATUMS_OLD_SNAPSHOT table, 6-47
- MDSYS.SDO_DIST_UNITS view, 6-49
- MDSYS.SDO_ELLIPSOIDS_OLD_FORMAT table, 6-49
- MDSYS.SDO_ELLIPSOIDS_OLD_SNAPSHOT table, 6-49
- MDSYS.SDO_GCDR package, 23-1
- MDSYS.SDO_GEOM_PATH_INFO type, 16-3
- MDSYS.SDO_OLS package, 27-1
- MDSYS.SDO_PROJECTIONS_OLD_FORMAT table, 6-50
- MDSYS.SDO_PROJECTIONS_OLD_SNAPSHOT table, 6-50

- MDSYS.SDO_SAM package, 29-1
- MDSYS.SDO_WFS_LOCK package, 33-1
- MDSYS.SDO_WFS_PROCESS package, 22-1, 34-1
- mean sea level (MSL), 6-4
- measure, 7-3
 - populating, 7-3
 - resetting, 25-67
 - reversing, 25-71
 - with multiline strings and polygons with holes, 7-5
- measure range, 7-5
- MEASURE_RANGE function, 25-55
- MEASURE_TO_PERCENTAGE function, 25-56
- messages
 - Spatial error messages, 1-27
- methods
 - SDO_GEOMETRY object type, 2-12
- migration
 - See* upgrading
- min-corner values
 - for three-dimensional rectangle, 1-19
- minimum bounding rectangle (MBR)
 - AVERAGE_MBR procedure, 31-2
 - EXTENT_OF function, 31-7
 - geodetic, 6-5
 - SDO_AGGR_MBR aggregate function, 20-8
 - SDO_MAX_MBR_ORDINATE function, 24-34
 - SDO_MBR function, 24-36
 - SDO_MIN_MBR_ORDINATE function, 24-38
- mining
 - See* data mining
- MIX_INFO procedure, 31-8
- MOVE_SDO procedure, 1-27
- MSL (mean sea level), 6-4
- multi-address routing, 13-2
- multiline string
 - boundary of, 1-11
 - LRS measure values, 7-5
- multimaster replication
 - SDO_GEOMETRY objects, B-4
- multipolygon, 2-22

N

- NaC coordinate reference system, 6-70
- NADCON grids
 - converting Spatial XML format to NADCON format, 21-10
 - converting to Spatial XML format, 21-6
- name conflicts
 - avoiding with SQL Multimedia implementations, 3-8
- naming considerations
 - Spatial table and column names, 2-44
- nearest neighbor
 - SDO_NN operator, 19-23
 - SDO_NN_DISTANCE operator, 19-28
- neighborhood influence, 8-3
- NODE table
 - routing engine use of, 13-25

- non-ellipsoidal height, 6-3
- normal vector, 1-24
- NTv2 grids
 - converting Spatial XML format to NTv2 format, 21-12
 - converting to Spatial XML format, 21-8

O

- object types
 - embedding SDO_GEOMETRY objects in, 9-1, 9-4
- OCG (Open Geospatial Consortium) simple features conformance, 1-26
- OCI (Oracle Call Interface) examples, 1-28
- ODM
 - See Oracle Data Mining (ODM)
- offset, 7-3
 - FIND_OFFSET function, 25-30
- OFFSET_GEOM_SEGMENT function, 25-58
- offsetting
 - geometric segment, 7-12
- OGC_X and OGC_Y function names, 1-26
- ON
 - SDO_ON operator, 19-30
 - topological relationship, 1-12
- Open Geospatial Consortium (OCG) simple features conformance, 1-26
- OpenLS
 - subprogram reference information, 27-1
- OPENLS_DIR_BUSINESS_CHAINS table, 12-3
- OPENLS_DIR_BUSINESSES table, 12-2
- OPENLS_DIR_CATEGORIES table, 12-3
- OPENLS_DIR_CATEGORIZATIONS table, 12-4
- OPENLS_DIR_CATEGORY_TYPES table, 12-4
- OPENLS_DIR_SYNONYMS table, 12-5
- operators
 - ORDERED optimizer hint with, 1-13
 - SDO_FILTER, 19-14
 - SDO_JOIN, 19-19
 - overview, 1-13
 - performance-related guidelines, 1-13
 - SDO_ANYINTERACT, 19-3
 - SDO_CONTAINS, 19-5
 - SDO_COVEREDBY, 19-7
 - SDO_COVERS, 19-9
 - SDO_EQUAL, 19-11
 - SDO_FILTER, 19-13
 - SDO_INSIDE, 19-16
 - SDO_JOIN, 19-18
 - SDO_NN, 19-23
 - SDO_NN_DISTANCE, 19-28
 - SDO_ON, 19-30
 - SDO_OVERLAPBDYDISJOINT, 19-32
 - SDO_OVERLAPBDYINTERSECT, 19-34
 - SDO_OVERLAPS, 19-36
 - SDO_RELATE, 19-38
 - SDO_TOUCH, 19-42
 - SDO_WITHIN_DISTANCE, 19-44
- optimized box, 2-11
- optimized rectangle, 2-10

- three-dimensional, 1-19
- optimizer hint (ORDERED) with spatial operators, 1-13
 - SDO_FILTER, 19-14
 - SDO_JOIN, 19-19
- Oracle Call Interface (OCI) examples, 1-28
- Oracle Data Mining (ODM)
 - spatial analysis and mining information, 8-1
- Oracle Database 10g
 - upgrading Spatial to, A-1
- Oracle Locator
 - See Locator
- Oracle Multimedia
 - proper installation required for Locator, B-1
- Oracle Workspace Manager
 - using with WFS, 15-24
- ORDERED optimizer hint with spatial operators, 1-13
 - SDO_FILTER, 19-14
 - SDO_JOIN, 19-19
- Ordnance Survey grid transformation, 6-67
- oriented point
 - illustration and example, 2-27
- orthometric height, 6-10
- OSTN02/OSGM02 grid transformation, 6-67
- OVERLAPBDYDISJOINT
 - SDO_OVERLAPBDYDISJOINT operator, 19-32
 - topological relationship, 1-11
- OVERLAPBDYINTERSECT
 - SDO_OVERLAPBDYINTERSECT operator, 19-34
 - topological relationship, 1-12
- OVERLAPS
 - SDO_OVERLAPS operator, 19-36

P

- parallel execution for index creation and rebuilding, 18-3, 18-5, 18-9
- parser profiles
 - GC_PARSER_PROFILEAFS table, 11-19
 - GC_PARSER_PROFILES table, 11-16
- PARTITION table
 - routing engine use of, 13-25
- partitioned spatial indexes, 5-2
 - exchanging partitions, 5-5
- PERCENTAGE_TO_MEASURE function, 25-61
- performance and tuning information, 1-26
 - for Spatial operators, 1-13
- PL/SQL and SQL examples, 1-28
- plugins
 - registering for record type, 16-26
- point
 - data, 1-5
 - illustration and examples of point-only geometry, 2-25
 - interior on surface of polygon, 32-49
 - locating on geometric segment, 7-12
 - LRS, 7-5
 - on surface of polygon, 24-40
 - oriented point, 2-27

- projection of onto geometric segment, 7-5, 7-13
- shape, 7-2
- point clouds
 - clipping, 28-2
 - converting to geometry, 28-11
 - dropping dependencies, 28-6
 - getting point IDs, 28-7
 - initializing, 28-8
 - modeling solids as, 1-18
 - subprograms, 28-1
- point of interest (POI)
 - GC_POI_<suffix> table, 11-22
- POINT_AT_BEARING function, 32-50
- policies
 - RLS restriction relating to SDO_FILTER, 19-14
- polygon
 - area of, 24-11
 - boundary of, 1-11
 - buffer, 24-13
 - centroid, 24-16
 - compound, 2-10
 - exterior and interior rings, 2-8, 2-21, 2-22
 - interior point on surface, 32-49
 - point on surface, 24-40
 - self-crossing not supported, 1-4
 - self-intersecting polygons, 24-52
 - with hole (LRS measure values), 7-5
- polygon collection, 2-22
- polygon data, 1-5
- POLYGONTOLINE function, 32-52
- PopulateFeatureTypeXMLInfo procedure, 34-12
- populating
 - measure, 7-3
- pre_geocoded_location element, 13-18
- pre_geocoded_locations attribute
 - of route request, 13-18
- PREPARE_FOR_TTS procedure, 32-53
- primary filter, 1-8, 5-8, 5-9
- primitive types, 1-3
- problems in current release, 6-69
- PROJECT_PT function, 25-63
- projected coordinates, 1-5, 6-2
- projections, 7-5, 7-13
 - MDSYS.SDO_PROJECTIONS_OLD_FORMAT table, 6-50
 - MDSYS.SDO_PROJECTIONS_OLD_SNAPSHOT table, 6-50
 - PROJECT_PT function, 25-63
- proxy authentication
 - identity propagation option, 17-2
- publishFeatureType method, 15-15
- PublishFeatureType procedure, 34-13
- publishRecordType method, 16-18

Q

- quality
 - R-tree, 1-10
- QUALITY_DEGRADATION function
 - (deprecated), 31-10

- query, 5-7
- query model for Spatial, 1-8
- query window, 5-8
- querying geometric segments
 - subprograms for, 25-2

R

- range
 - measure, 7-5
- README file
 - for Spatial, GeoRaster, and topology and network data models, 1-28
- rebuilding
 - spatial indexes, 18-4
- record types
 - dropping, 16-16
 - getting ID, 16-17
 - granting access to a user, 16-18
 - publishing, 16-18
 - registering plugin, 16-26
 - revoking access from a user, 16-26
 - setting capabilities information, 16-27
- record view map
 - deleting, 16-16
- record view maps (setting), 16-27
- rectangle
 - minimum bounding, 31-7
 - three-dimensional optimized, 1-19
 - type, 2-10
- rectification of geometries, 32-54
- RECTIFY_GEOMETRY function, 32-54
- REDEFINE_GEOM_SEGMENT procedure, 25-65
- redefining
 - geometric segment, 7-8
- RegisterFeatureTable procedure, 33-3
- RegisterMTableView procedure, 34-18
- registerTypePluginMap method, 16-26
- RELATE function, 24-4
 - See also* SDO_RELATE operator
- relational feature types (WFS), 15-2
- release number (Spatial)
 - retrieving, 1-26
- REMOVE_DUPLICATE_VERTICES function, 32-56
- replication
 - multimaster, B-4
 - object, B-3
- RESET_MEASURE procedure, 25-67
- restrictions in current release, 6-69
- return_detailed_geometry attribute
 - of route request, 13-17
- return_driving_directions attribute
 - of route request, 13-17
- return_hierarchical_driving_directions attribute
 - of route request, 13-17
- return_locations attribute
 - of route request, 13-17
- return_route_edge_ids attribute
 - of route request, 13-17
- return_route_geometry attribute

- of batch route request, 13-23
- of route request, 13-17
- return_segment_geometry attribute
 - of batch route request, 13-23
 - of route request, 13-17
- return_subroute_edge_ids attribute
 - of route request, 13-17
- return_subroute_geometry attribute
 - of route request, 13-17
- return_subroutes attribute
 - of route request, 13-17
- reverse geocoding, 23-11
- REVERSE_GEOCODE function, 23-11
- REVERSE_GEOMETRY function, 25-69
- REVERSE_LINestring function, 32-58
- REVERSE_MEASURE function, 25-71
- REVOKE_PREFERENCE_FOR_OP procedure, 21-38
- revokeFeatureTypeFromUser method, 15-23
- RevokeFeatureTypeFromUser procedure, 34-21
- RevokeMDAccessFromUser procedure, 34-22
- revokeMDAccessToUser method, 15-23, 16-26
- revokeRecordTypeFromUser method, 16-26
- ring
 - exterior and interior polygon, 2-8
 - extracting from a geometry, 32-21, 32-24
- RLS
 - restriction regarding fine-grained access control policies and SDO_FILTER, 19-14
- road segments
 - GC_ROAD_SEGMENT_<suffix> table, 11-26
- road_preference attribute
 - of batch route request, 13-23
 - of route request, 13-17
- roads
 - GC_ROAD_<suffix> table, 11-24
- rollback segment
 - R-tree index creation, 5-7
- route geometry
 - in route request, 13-17
- route requests, 13-16
 - DTD, 13-14
 - example, 13-9
 - previously geocoded locations, 13-13
 - input_location element, 13-18
 - pre_geocoded_location element, 13-18
- route responses
 - DTD, 13-19
 - example, 13-9
 - previously geocoded locations, 13-14
- route_preference attribute
 - of route request, 13-17
- route_request element, 13-16
- routing engine
 - configuring, 13-3
 - data structures used by, 13-24
 - deploying, 13-3
 - multi-address routing, 13-2
 - overview, 13-1
 - XML API, 13-8
- R-tree indexes

- description of indexing process, 1-9
- rebuilding, 18-4
- requirements before creating, 5-7
- sequence object, 2-49
- R-tree quality, 1-10

S

- SCALE_GEOM_SEGMENT function, 25-73
- scaling
 - geometric segment, 7-11
- schemas
 - creating index on table in another schema, 5-2
 - invoking SDO_JOIN on table in another schema, 19-21
- SDO_ADDR_ARRAY data type, 11-8
- SDO_AGGR_CENTROID aggregate function, 20-2
- SDO_AGGR_CONCAT_LINES aggregate function, 20-3
- SDO_AGGR_CONVEXHULL aggregate function, 20-5
- SDO_AGGR_LRS_CONCAT aggregate function, 20-6
- SDO_AGGR_MBR aggregate function, 20-8
- SDO_AGGR_SET_UNION aggregate function, 20-9
- SDO_AGGR_UNION aggregate function, 20-11
 - complex examples, C-5
- SDO_ALPHA_SHAPE function, 24-7
- SDO_ANGLE_UNITS table, 6-46
- SDO_ANYINTERACT operator, 19-3
- SDO_ARC_DENSIFY function, 24-9
- SDO_AREA function, 24-11
- SDO_AREA_UNITS view, 6-47
- SDO_BUFFER function, 24-13
- SDO_CENTROID function, 24-16
- SDO_CLOSEST_POINTS procedure, 24-18
- SDO_CONCAVEHULL function, 24-20
- SDO_CONCAVEHULL_BOUNDARY function, 24-22
- SDO_CONTAINS operator, 19-5
- SDO_CONVEXHULL function, 24-24
- SDO_COORD_AXES table, 6-20
- SDO_COORD_AXIS_NAMES table, 6-20
- SDO_COORD_OP_METHODS table, 6-21
- SDO_COORD_OP_PARAM_USE table, 6-21
- SDO_COORD_OP_PARAM_VALS table, 6-22
- SDO_COORD_OP_PARAMS table, 6-23
- SDO_COORD_OP_PATHS table, 6-23
- SDO_COORD_OPS table, 6-23
- SDO_COORD_REF_SYS table, 6-25
- SDO_COORD_REF_SYSTEM view, 6-27
- SDO_COORD_SYS table, 6-27
- SDO_COVEREDBY operator, 19-7
- SDO_COVERS operator, 19-9
- SDO_CRS_COMPOUND view, 6-27
- SDO_CRS_ENGINEERING view, 6-28
- SDO_CRS_GEOCENTRIC view, 6-28
- SDO_CRS_GEOGRAPHIC2D view, 6-29
- SDO_CRS_GEOGRAPHIC3D view, 6-29
- SDO_CRS_PROJECTED view, 6-30

SDO_CRS_VERTICAL view, 6-30
 SDO_CS package, 21-1
 ADD_PREFERENCE_FOR_OP, 21-4
 CONVERT_NADCON_TO_XML, 21-6
 CONVERT_NTV2_TO_XML, 21-8
 CONVERT_XML_TO_NADCON, 21-10
 CONVERT_XML_TO_NTV2, 21-12
 CREATE_CONCATENATED_OP, 21-14
 CREATE_OBVIOUS_EPSG_RULES, 21-15
 CREATE_PREF_CONCATENATED_OP, 21-16
 DELETE_ALL_EPSG_RULES, 21-18
 DELETE_OP, 21-19
 DETERMINE_CHAIN, 21-20
 DETERMINE_DEFAULT_CHAIN, 21-22
 FIND_GEOG_CRS, 21-23
 FIND_PROJ_CRS, 21-25
 FIND_SRID, 21-27
 FROM_OGC_SIMPLEFEATURE_SRS, 21-31
 FROM_USNG, 21-32
 GET_EPSG_DATA_VERSION function, 21-33
 MAKE_3D, 21-34, 21-35
 MAP_EPSG_SRID_TO_ORACLE, 21-36
 MAP_ORACLE_SRID_TO_EPSG, 21-37
 REVOKE_PREFERENCE_FOR_OP, 21-38
 TO_OGC_SIMPLEFEATURE_SRS, 21-39
 TO_USNG, 21-40
 TRANSFORM, 21-42
 TRANSFORM_LAYER, 21-44
 UPDATE_WKTS_FOR_ALL_EPSG_CRS, 21-46
 UPDATE_WKTS_FOR_EPSG_CRS, 21-47
 UPDATE_WKTS_FOR_EPSG_DATUM, 21-48
 UPDATE_WKTS_FOR_EPSG_ELLIPS, 21-49
 UPDATE_WKTS_FOR_EPSG_OP, 21-50
 UPDATE_WKTS_FOR_EPSG_PARAM, 21-51
 UPDATE_WKTS_FOR_EPSG_PM, 21-52
 VALIDATE_WKT, 21-53
 SDO_CSW_PROCESS package
 DeleteCapabilitiesInfo, 22-2
 DeleteDomainInfo, 22-3
 DeletePluginMap, 22-4
 DeleteRecordViewMap, 22-5
 GetRecordTypeId, 22-6
 InsertCapabilitiesInfo, 22-7
 InsertDomainInfo, 22-8
 InsertPluginMap, 22-9
 InsertRecordViewMap, 22-10
 InsertRtDataUpdated, 22-12
 InsertRtMDUUpdated, 22-13
 SDO_DATUM_ENGINEERING view, 6-31
 SDO_DATUM_GEODETTIC view, 6-32
 SDO_DATUM_VERTICAL view, 6-32
 SDO_DATUMS table, 6-33
 SDO_DATUMS_OLD_FORMAT table, 6-47
 SDO_DATUMS_OLD_SNAPSHOT table, 6-47
 SDO_DIFFERENCE function, 24-26
 SDO_DIST_UNITS view, 6-49
 SDO_DISTANCE function, 24-28
 SDO_ELEM_INFO attribute, 2-7
 SDO_ELEM_INFO_ARRAY type, 2-5
 SDO_ELLIPSOIDS table, 6-34
 SDO_ELLIPSOIDS_OLD_FORMAT table, 6-49
 SDO_ELLIPSOIDS_OLD_SNAPSHOT table, 6-49
 SDO_EQUAL operator, 19-11
 SDO_ETYPE value, 2-8, 2-9
 SDO_FILTER operator, 19-13
 SDO_GCDR package, 23-1
 CREATE_PROFILE_TABLES, 23-2
 GEOCODE, 23-3
 GEOCODE_ADDR, 23-4
 GEOCODE_ADDR_ALL, 23-6
 GEOCODE_ALL, 23-8
 GEOCODE_AS_GEOMETRY, 23-10
 REVERSE_GEOCODE, 23-11
 SDO_GEO_ADDR data type and constructors, 11-5
 SDO_GEOM package
 RELATE, 24-4
 SDO_ALPHA_SHAPE, 24-7
 SDO_ARC_DENSIFY, 24-9
 SDO_AREA, 24-11
 SDO_BUFFER, 24-13
 SDO_CENTROID, 24-16
 SDO_CLOSEST_POINTS, 24-18
 SDO_CONCAVEHULL, 24-20
 SDO_CONCAVEHULL_BOUNDARY, 24-22
 SDO_CONVEXHULL, 24-24
 SDO_DIFFERENCE, 24-26
 SDO_DISTANCE, 24-28
 SDO_INTERSECTION, 24-30
 SDO_LENGTH, 24-32
 SDO_MAX_MBR_ORDINATE, 24-34
 SDO_MBR, 24-36
 SDO_MIN_MBR_ORDINATE, 24-38
 SDO_POINTONSURFACE, 24-40
 SDO_TRIANGULATE, 24-42
 SDO_UNION, 24-43
 SDO_VOLUME, 24-45
 SDO_XOR, 24-47
 VALIDATE_GEOMETRY_WITH_CONTEXT, 24-49
 VALIDATE_LAYER_WITH_CONTEXT, 24-53
 WITHIN_DISTANCE, 24-56
 SDO_GEOM_PATH_INFO
 MDSYS.SDO_GEOM_PATH_INFO type, 16-3
 SDO_GEOMETRY object type, 2-5
 constructors, 2-13
 embedding in user-defined type, 9-1, 9-4
 in function-based indexes, 9-3
 methods (member functions), 2-12
 SDO_GTYPE attribute, 2-5
 constraining data to a geometry type, 5-2
 Get_Dims method, 2-12
 Get_GType method, 2-12
 Get_LRS_Dim method, 2-12
 SDO_INDEX_TABLE entry in index metadata views, 2-49
 SDO_INDX_DIMS keyword, 7-7, 18-2
 SDO_INSIDE operator, 19-16
 SDO_INTERPRETATION value, 2-8
 SDO_INTERSECTION function, 24-30
 SDO_JOIN operator, 19-18

- cross-schema invocation, 19-21
- SDO_KEYWORDARRAY data type, 11-8
- SDO_LENGTH function, 24-32
- SDO_LRS package
 - CLIP_GEOM_SEGMENT, 25-5
 - CONCATENATE_GEOM_SEGMENTS, 25-7
 - CONNECTED_GEOM_SEGMENTS, 25-10
 - CONVERT_TO_LRS_DIM_ARRAY, 25-12
 - CONVERT_TO_LRS_GEOM, 25-14
 - CONVERT_TO_LRS_LAYER, 25-16
 - CONVERT_TO_STD_DIM_ARRAY, 25-18
 - CONVERT_TO_STD_GEOM, 25-19
 - CONVERT_TO_STD_LAYER, 25-20
 - DEFINE_GEOM_SEGMENT, 25-22
 - DYNAMIC_SEGMENT, 25-25
 - FIND_LRS_DIM_POS, 25-27
 - FIND_MEASURE, 25-28
 - FIND_OFFSET, 25-30
 - GEOM_SEGMENT_END_MEASURE, 25-32
 - GEOM_SEGMENT_END_PT, 25-33
 - GEOM_SEGMENT_LENGTH, 25-34
 - GEOM_SEGMENT_START_MEASURE, 25-35
 - GEOM_SEGMENT_START_PT, 25-36
 - GET_MEASURE, 25-37
 - GET_NEXT_SHAPE_PT, 25-38
 - GET_NEXT_SHAPE_PT_MEASURE, 25-40
 - GET_PREV_SHAPE_PT, 25-42
 - GET_PREV_SHAPE_PT_MEASURE, 25-44
 - IS_GEOM_SEGMENT_DEFINED, 25-46
 - IS_MEASURE_DECREASING, 25-47
 - IS_MEASURE_INCREASING, 25-48
 - IS_SHAPE_PT_MEASURE, 25-49
 - LOCATE_PT, 25-51
 - LRS_INTERSECTION, 25-53
 - MEASURE_RANGE, 25-55
 - MEASURE_TO_PERCENTAGE, 25-56
 - OFFSET_GEOM_SEGMENT, 25-58
 - PERCENTAGE_TO_MEASURE, 25-61
 - PROJECT_PT, 25-63
 - REDEFINE_GEOM_SEGMENT, 25-65
 - RESET_MEASURE, 25-67
 - REVERSE_GEOMETRY, 25-69
 - REVERSE_MEASURE, 25-71
 - SCALE_GEOM_SEGMENT, 25-73
 - SET_PT_MEASURE, 25-75
 - SPLIT_GEOM_SEGMENT, 25-78
 - TRANSLATE_MEASURE, 25-80
 - VALID_GEOM_SEGMENT, 25-82
 - VALID_LRS_PT, 25-83
 - VALID_MEASURE, 25-84
 - VALIDATE_LRS_GEOMETRY, 25-86
- SDO_MAX_MBR_ORDINATE function, 24-34
- SDO_MBR function, 24-36
- SDO_MIGRATE package
 - TO_CURRENT, 26-2
- SDO_MIN_MBR_ORDINATE function, 24-38
- SDO_NN operator, 19-23
 - complex examples, C-3
 - optimizer hints, 19-25
- SDO_NN_DISTANCE ancillary operator, 19-28
- SDO_NN_DISTANCE operator
 - complex examples, C-3
- SDO_OLS package, 27-1
 - MakeOpenLSClobRequest, 27-2
 - MakeOpenLSRequest, 27-4
- SDO_ON operator, 19-30
- SDO_ORDINATE_ARRAY type, 2-5
- SDO_ORDINATES attribute, 2-11
- SDO_OVERLAPBDYDISJOINT operator, 19-32
- SDO_OVERLAPBDYINTERSECT operator, 19-34
- SDO_OVERLAPS operator, 19-36
- SDO_PC object type, 2-18
- SDO_PC_BLK object type, 2-20
- SDO_PC_BLK_TYPE object type, 2-20
- SDO_PC_PKG package
 - CLIP_PC, 28-2
 - CREATE_PC, 28-4
 - DROP_DEPENDENCIES, 28-6
 - GET_PT_IDS, 28-7
 - INIT, 28-8
 - TO_GEOMETRY, 28-11
- SDO_POINT attribute, 2-7
- SDO_POINT_TYPE object type, 2-5
- SDO_POINTONSURFACE function, 24-40
- SDO_PREFERRED_OPS_SYSTEM table, 6-35
- SDO_PREFERRED_OPS_USER table, 6-35
- SDO_PRIME_MERIDIANS table, 6-36
- SDO_PROJECTIONS_OLD_FORMAT table, 6-50
- SDO_PROJECTIONS_OLD_SNAPSHOT table, 6-50
- SDO_REGAGGR object type, 29-6, 29-19
- SDO_REGAGGRSET object type, 29-6, 29-19
- SDO_REGION object type, 29-22
- SDO_REGIONSET object type, 29-22
- SDO_RELATE operator, 19-38
- SDO_ROWIDPAIR object type, 19-18
- SDO_ROWIDSET data type, 19-18
- SDO_RTREE_SEQ_NAME sequence object, 2-49
- SDO_SAM package, 29-1
 - AGGREGATES_FOR_GEOMETRY, 29-3
 - AGGREGATES_FOR_LAYER, 29-5
 - BIN_GEOMETRY, 29-7
 - BIN_LAYER, 29-9
 - COLOCATED_REFERENCE_FEATURES, 29-11
 - SIMPLIFY_GEOMETRY, 29-13
 - SIMPLIFY_LAYER, 29-15
 - SPATIAL_CLUSTERS, 29-17
 - TILED_AGGREGATES, 29-18
 - TILED_BINS, 29-21
- SDO_SRID attribute, 2-7
- SDO_ST_TOLERANCE table, 3-8
- SDO_STARTING_OFFSET value, 2-7
- SDO_TFM_CHAIN type, 6-19
- SDO_TIN object type, 2-15
- SDO_TIN_BLK object type, 2-18
- SDO_TIN_BLK_TYPE object type, 2-18
- SDO_TIN_PKG package
 - CLIP_TIN, 30-2
 - CREATE_TIN, 30-4
 - DROP_DEPENDENCIES, 30-6
 - INIT, 30-7

- TO_GEOMETRY, 30-10
- SDO_TOUCH operator, 19-42
- SDO_TRIANGULATE function, 24-42
- SDO_TUNE package
 - AVERAGE_MBR, 31-2
 - ESTIMATE_RTREE_INDEX_SIZE, 31-4
 - EXTENT_OF, 31-7
 - MIX_INFO, 31-8
 - QUALITY_DEGRADATION (deprecated function), 31-10
- SDO_UNION function, 24-43
- SDO_UNIT column
 - in SDO_AREA_UNITS table, 6-47
 - in SDO_DIST_UNITS table, 6-49
- SDO_UNITS_OF_MEASURE table, 6-36
- SDO_UTIL package
 - AFFINETRANSFORMS, 32-4
 - APPEND, 32-10
 - BEARING_TILT_FOR_POINTS, 32-11
 - CIRCLE_POLYGON, 32-13
 - CONCAT_LINES, 32-15
 - CONVERT_UNIT, 32-17
 - DROP_WORK_TABLES, 32-18
 - ELLIPSE_POLYGON, 32-19
 - EXTRACT, 32-21
 - EXTRACT_ALL, 32-24
 - EXTRACT3D, 32-28
 - EXTRUDE, 32-30
 - FROM_GML311GEOMETRY, 32-33
 - FROM_GMLGEOMETRY, 32-35
 - FROM_KMLGEOMETRY, 32-37
 - FROM_WKBGEOMETRY, 32-39
 - FROM_WKTGEOMETRY, 32-41
 - GETNUMELEM, 32-43
 - GETNUMVERTICES, 32-44
 - GETVERTICES, 32-45
 - INITIALIZE_INDEXES_FOR_TTS, 32-47
 - INTERIOR_POINT, 32-49
 - POINT_AT_BEARING, 32-50
 - POLYGONTOLINE, 32-52
 - PREPARE_FOR_TTS, 32-53
 - RECTIFY_GEOMETRY, 32-54
 - REMOVE_DUPLICATE_VERTICES, 32-56
 - REVERSE_LINestring, 32-58
 - SIMPLIFY, 32-59
 - TO_GML311GEOMETRY, 32-62
 - TO_GMLGEOMETRY, 32-67
 - TO_KMLGEOMETRY, 32-73
 - TO_WKBGEOMETRY, 32-75
 - TO_WKTGEOMETRY, 32-77
 - VALIDATE_WKBGEOMETRY, 32-79
 - VALIDATE_WKTGEOMETRY, 32-81
- SDO_VERSION function, 1-26
- SDO_VOLUME function, 24-45
- SDO_WFS_LOCK package, 33-1
 - EnableDBTxns, 33-2
 - RegisterFeatureTable, 33-3
 - UnRegisterFeatureTable, 33-4
- SDO_WFS_PROCESS package, 22-1, 34-1
 - DropFeatureType, 34-3
 - DropFeatureTypes, 34-4
 - GenCollectionProcs, 34-5
 - GetFeatureTypeId, 34-6
 - GrantFeatureTypeToUser, 34-7
 - GrantMDAccessToUser, 34-8
 - InsertCapabilitiesInfo, 34-9
 - InsertFtDataUpdated, 34-10
 - InsertFtMDUpdated, 34-11
 - PopulateFeatureTypeXMLInfo, 34-12
 - PublishFeatureType, 34-13
 - RegisterMTableView, 34-18
 - RevokeFeatureTypeFromUser, 34-21
 - RevokeMDAccessFromUser, 34-22
 - UnRegisterMTableView, 34-23
- SDO_WITHIN_DISTANCE operator, 19-44
 - complex examples, C-2
- SDO_XOR function, 24-47
- SDOAGGRTYPE object type, 1-14
- sdows.ear file
 - deploying, 10-2
- sea level
 - gravity-related height, 6-10
- secondary filter, 1-8, 5-9
- segment geometry
 - in route request, 13-17
- segments
 - geometric, 7-1
 - in a route or subroute, 13-2
- self-crossing line strings and polygons, 1-4
- self-intersecting polygons, 24-52
- self-joins
 - optimizing, 19-20
- semi-major axis, 6-34, 6-50
- semi-minor axis, 6-35
- sequence object for R-tree index, 2-49
- SET_PT_MEASURE procedure, 25-75
- setCapabilitiesInfo method, 16-27
- setDomainInfo method, 16-27
- setRecordViewMap method, 16-27
- setXMLTableIndexInfo method, 15-23, 16-28
- shape point, 7-2
 - determining if measure value is a shape point, 25-49
 - getting measure of next, 25-40
 - getting measure of previous, 25-44
 - getting next, 25-38
 - getting previous, 25-42
- Shapefiles
 - loading into Spatial, D-1
- SIGN_POST table
 - routing engine use of, 13-26
- simple element, 2-8
- simple features (OGC)
 - Oracle Spatial conformance, 1-26
- simplification of geometries, 32-59
- SIMPLIFY function, 32-59
- SIMPLIFY_GEOMETRY function, 29-13
- SIMPLIFY_LAYER procedure, 29-15
- single application user
 - identity propagation option, 17-2

- size requirements (hardware) for spatial applications, 1-27
- solids
 - exterior and interior, 2-8
 - modeling of, 1-18
 - SDO_ETYPE value, 2-11
 - volume of, 24-45
- SORT_AREA_SIZE parameter
 - R-tree index creation, 5-7
- sort_by_distance attribute
 - of batch route request, 13-23
- spatial aggregate functions
 - See aggregate functions
- spatial analysis and mining
 - conceptual and usage information, 8-1
 - function reference information, 29-1
- spatial binning, 8-3
 - See alsobins
- spatial clustering, 8-4
- spatial correlation, 8-3
- spatial data mining
 - conceptual and usage information, 8-1
 - function reference information, 29-1
- spatial data structures, 2-1
- spatial data types, 2-1
- spatial index
 - See index
- spatial join, 5-12
 - SDO_JOIN operator, 19-18
- Spatial metadata tables
 - moving, 1-27
- spatial operators
 - See operators
- spatial query, 5-7
- spatial reference systems
 - conceptual and usage information, 6-1
 - example, 6-72
 - subprogram reference information, 21-1
- spatial routing engine
 - See routing engine
- Spatial Web services
 - client setup, 10-2
 - demo files, 10-6
 - identity propagation, 17-2
 - introduction, 10-1
 - user management, 17-1
 - virtual private databases, 17-3
- SPATIAL_CLUSTERS function, 29-17
- SPATIAL_CSW_ADMIN_USR account and schema, 1-25
- SPATIAL_WFS_ADMIN_USR account and schema, 1-25
- spheroids
 - MDSYS.SDO_ELLIPSOIDS_OLD_FORMAT table, 6-49
 - MDSYS.SDO_ELLIPSOIDS_OLD_SNAPSHOT table, 6-49
- SPLIT_GEOM_SEGMENT procedure, 25-78
- splitting
 - geometric segment, 7-9
- SQL and PL/SQL examples, 1-28
- SQL Multimedia
 - avoiding name conflicts, 3-8
 - FROM_WKBGEOMETRY function, 32-39
 - FROM_WKTGEOMETRY function, 32-41
 - ST_GEOMETRY type, 3-1
 - support in Spatial, 3-1
 - TO_WKBGEOMETRY function, 32-75
 - TO_WKTGEOMETRY function, 32-77
 - tolerance value, 3-8
 - VALIDATE_WKBGEOMETRY function, 32-79
 - VALIDATE_WKTGEOMETRY function, 32-81
- SQL Multimedia standard
 - ST_CoordDim method, 2-12
 - ST_IsValid method, 2-12
- SQL statements
 - for indexing spatial data, 18-1
- SQL*Loader, 4-1
- SRID
 - checking for existence, 21-27
 - finding, 21-27
 - in USER_SDO_GEOM_METADATA, 2-46
 - mapping Oracle to EPSG, 21-37
 - SDO_SRID attribute in SDO_GEOMETRY, 2-7
- ST_ANNOTATION_TEXT constructor, 3-8
- ST_CoordDim method, 2-12
- ST_GEOMETRY type, 3-1
- ST_IsValid method, 2-12
- start location for route, 13-16
- subprograms
 - coordinate system transformation, 21-1
 - data mining, 29-1
 - geocoding, 23-1
 - geometry, 24-1
 - linear referencing, 25-1
 - OpenLS, 27-1
 - point clouds, 28-1
 - SDO_MIGRATE, 26-1
 - spatial analysis, 29-1
 - TINs, 30-1
 - tuning, 31-1
 - utility, 32-1
 - WFS, 33-1
 - WFS processing, 22-1, 34-1
- subroutes
 - explanation of, 13-2
 - returning coordinates in route request, 13-17
 - returning edge IDs in route request, 13-17
 - returning in route request, 13-17
- surface normal, 1-24
- surfaces, 2-8
 - modeling of, 1-17
 - SDO_ETYPE value, 2-10

T

- table names
 - restrictions on spatial table names, 2-45
- TABLE_NAME (in USER_SDO_GEOM_METADATA), 2-45

- textures
 - using, 1-20
- TFM_PLAN object type, 6-19
- three-dimensional (3D)
 - formats of LRS functions, 7-7
 - not supported with geodetic data, 6-69
 - spatial objects, 1-15
 - solids, 1-18
 - surfaces, 1-17
- TILED_AGGREGATES function, 29-18
- TILED_BINS function, 29-21
- time_unit attribute
 - of route request, 13-18
- TINS
 - subprograms, 30-1
- TINs
 - clipping, 30-2
 - converting to geometry, 30-10
 - creating, 28-4, 30-4
 - dropping dependencies, 30-6
 - initializing, 30-7
- TINs (triangulated irregular networks), 1-17
- TO_CURRENT procedure and function, 26-2
- TO_GEOMETRY procedure, 28-11, 30-10
- TO_GML311GEOMETRY function, 32-62
- TO_GMLGEOMETRY function, 32-67
- TO_KMLGEOMETRY function, 32-73
- TO_OGC_SIMPLEFEATURE_SRS function, 21-39
- TO_USNG function, 21-40
- TO_WKBGEOMETRY function, 32-75
- TO_WKTGEOMETRY function, 32-77
- tolerance, 1-6
 - for SQL Multimedia types, 3-8
 - with LRS functions, 7-15
- TOUCH
 - SDO_TOUCH operator, 19-42
 - topological relationship, 1-11
- transactional insertion of spatial data, 4-3
- TRANSFORM function, 21-42
- TRANSFORM_LAYER procedure, 21-44
 - table for transformed layer, 21-45
- transformation, 6-2
 - arcs and circles not supported, 6-6
- TRANSLATE_MEASURE function, 25-80
- transportable tablespaces
 - initializing spatial indexes, 32-47
 - preparing for when using spatial indexes, 32-53
- triangulated irregular networks (TINs), 1-17
- triangulation
 - SDO_TRIANGULATE function, 24-42
- tuning and performance information, 1-26
 - for spatial operators, 1-13
- tuning subprograms, 31-1
- two-tier query model, 1-8
- type zero (0) element, 2-29

U

- unformatted addresses, 11-2
- union, 24-43

- unit of measurement
 - MDSYS tables, 2-49
- UNIT_NAME column
 - in SDO_ANGLE_UNITS table, 6-46
 - in SDO_AREA_UNITS table, 6-47
 - in SDO_DIST_UNITS table, 6-49
- unknown CRS coordinate reference system, 6-70
- UnRegisterFeatureTable procedure, 33-4
- UnRegisterMTableView procedure, 34-23
- UPDATE_WKTS_FOR_ALL_EPSG_CRCS
 - procedure, 21-46
- UPDATE_WKTS_FOR_EPSG_CRCS procedure, 21-47
- UPDATE_WKTS_FOR_EPSG_DATUM
 - procedure, 21-48
- UPDATE_WKTS_FOR_EPSG_ELLIPS
 - procedure, 21-49
- UPDATE_WKTS_FOR_EPSG_OP procedure, 21-50
- UPDATE_WKTS_FOR_EPSG_PARAM
 - procedure, 21-51
- UPDATE_WKTS_FOR_EPSG_PM procedure, 21-52
- upgrading
 - data to current Spatial release, 26-2
 - GeoRaster, A-1
 - Spatial to current Oracle Database release, A-1
 - upgrading spatial data to current release, 26-2
- U.S. National Grid
 - SDO_CS.FROM_USNG function, 21-32
 - SDO_CS.TO_USNG function, 21-40
 - support in Oracle Spatial, 6-70
- use cases
 - for coordinate system transformation, 6-8
- USE_SPHERICAL use case name, 6-71
- USER_ANNOTATION_TEXT_METADATA
 - view, 3-9
- USER_SDO_GEOM_METADATA view, 2-44
- USER_SDO_INDEX_INFO view, 2-46
- USER_SDO_INDEX_METADATA view, 2-47
- user-defined coordinate reference system, 6-52
- user-defined data types
 - embedding SDO_GEOMETRY objects in, 9-1, 9-4
- utility subprograms, 32-1

V

- VALID_GEOM_SEGMENT function, 25-82
- VALID_LRS_PT function, 25-83
- VALID_MEASURE function, 25-84
- VALIDATE_GEOMETRY_WITH_CONTEXT
 - function, 24-49
- VALIDATE_LAYER_WITH_CONTEXT
 - procedure, 24-53
- VALIDATE_LRS_GEOMETRY function, 25-86
- VALIDATE_WKBGEOMETRY function, 32-79
- VALIDATE_WKT function, 21-53
- VALIDATE_WKTGEOMETRY function, 32-81
- validation of geometries
 - general and two-dimensional checks, 24-49
 - three-dimensional checks, 1-23
- vendor attribute
 - of route request, 13-16

- version number (Spatial)
 - retrieving, 1-26
- versioning (CSW)
 - disabling, 16-16
 - enabling, 16-17
- VERTEX_SET_TYPE data type, 32-45
- VERTEX_TYPE object type, 32-45
- vertices
 - maximum number in SDO_GEOMETRY object, 2-5
 - removing duplicate, 32-56
 - returning geometry coordinates as, 32-45
- views
 - ALL_ANNOTATION_TEXT_METADATA, 3-10
 - ALL_SDO_GEOM_METADATA, 2-44
 - ALL_SDO_INDEX_INFO, 2-46
 - ALL_SDO_INDEX_METADATA, 2-47
 - USER_ANNOTATION_TEXT_METADATA, 3-9
 - USER_SDO_GEOM_METADATA, 2-44
 - USER_SDO_INDEX_INFO, 2-46
 - USER_SDO_INDEX_METADATA, 2-47
- virtual private databases
 - Spatial Web services security, 17-3
- volume, 24-45
- VPDs
 - Spatial Web services security, 17-3

W

- Web services
 - client setup, 10-2
 - demo files, 10-6
 - introduction, 10-1
- well-known binary (WKB)
 - See* WKB
- well-known text (WKT)
 - See* WKT
- WFS
 - engine, 15-1
 - feature types, 15-2
 - Java API, 15-13, 16-15
 - subprogram reference information, 33-1
 - using with Oracle Workspace Manager, 15-24
- WFS processing
 - subprogram reference information, 22-1, 34-1
- WFSAdmin Java class, 15-13, 16-15
- WITHIN_DISTANCE function, 24-56
 - See also* SDO_WITHIN_DISTANCE operator
- WKB
 - FROM_WKBGEOMETRY function, 32-39
 - Get_WKB method, 2-12
 - TO_WKBGEOMETRY function, 32-75
 - VALIDATE_WKBGEOMETRY function, 32-79
- WKT, 6-43
 - FROM_WKTGEOMETRY function, 32-41
 - Get_WKT method, 2-12
 - procedures for updating, 6-46
 - TO_WKTGEOMETRY function, 32-77
 - UPDATE_WKTS_FOR_ALL_EPSG_CRS procedure, 21-46

- UPDATE_WKTS_FOR_EPSG_CRS procedure, 21-47
- UPDATE_WKTS_FOR_EPSG_DATUM procedure, 21-48
- UPDATE_WKTS_FOR_EPSG_ELLIPS procedure, 21-49
- UPDATE_WKTS_FOR_EPSG_OP procedure, 21-50
- UPDATE_WKTS_FOR_EPSG_PARAM procedure, 21-51
- UPDATE_WKTS_FOR_EPSG_PM procedure, 21-52
- VALIDATE_WKTGEOMETRY function, 32-81
- validating (given SRID), 21-53
- WKTEXT column of MDSYS.CS_SRS table, 6-43
 - procedures for updating value, 6-46
- Workspace Manager
 - executing SOAP request in workspace, 17-3
 - using with WFS, 15-24
- wsclient.jar file, 10-6
- WSConfig.xml file, 10-3

X

- XML API
 - routing engine, 13-8
- XML table index
 - setting information for a feature type, 15-23
 - setting information for record type, 16-28
- XMLTABLEINDEX index
 - checking for existence, 15-14, 16-17
 - creating on feature table, 15-13, 16-15
 - deleting on feature table, 15-14, 16-17
- XOR
 - SDO_XOR function, 24-47

Y

- Yellow Pages
 - See* business directory (YP)
- YP
 - See* business directory (YP)

Z

- zero
 - type 0 element, 2-29