

Oracle® Label Security

Administrator's Guide



18c
E87129-01
February 2018

The Oracle logo, consisting of a solid red square with the word "ORACLE" in white, uppercase, sans-serif font centered within it.

ORACLE®

Oracle Label Security Administrator's Guide, 18c

E87129-01

Copyright © 2006, 2018, Oracle and/or its affiliates. All rights reserved.

Primary Author: Sumit Jeloka

Contributors: Chi Ching Chui, Rishabh Gupta, John Kati, Lakshmi Kethana, Gopal Mulagund, Paul Needham, Hozefa Palitanawala, Vikram Pesati, Amoghavarsha Ramappa, Saikat Saha, Digvijay Sirmukaddam, Srividya Tata, Kamal Tbeileh, Peter Wahl

This software and related documentation are provided under a license agreement containing restrictions on use and disclosure and are protected by intellectual property laws. Except as expressly permitted in your license agreement or allowed by law, you may not use, copy, reproduce, translate, broadcast, modify, license, transmit, distribute, exhibit, perform, publish, or display any part, in any form, or by any means. Reverse engineering, disassembly, or decompilation of this software, unless required by law for interoperability, is prohibited.

The information contained herein is subject to change without notice and is not warranted to be error-free. If you find any errors, please report them to us in writing.

If this is software or related documentation that is delivered to the U.S. Government or anyone licensing it on behalf of the U.S. Government, then the following notice is applicable:

U.S. GOVERNMENT END USERS: Oracle programs, including any operating system, integrated software, any programs installed on the hardware, and/or documentation, delivered to U.S. Government end users are "commercial computer software" pursuant to the applicable Federal Acquisition Regulation and agency-specific supplemental regulations. As such, use, duplication, disclosure, modification, and adaptation of the programs, including any operating system, integrated software, any programs installed on the hardware, and/or documentation, shall be subject to license terms and license restrictions applicable to the programs. No other rights are granted to the U.S. Government.

This software or hardware is developed for general use in a variety of information management applications. It is not developed or intended for use in any inherently dangerous applications, including applications that may create a risk of personal injury. If you use this software or hardware in dangerous applications, then you shall be responsible to take all appropriate fail-safe, backup, redundancy, and other measures to ensure its safe use. Oracle Corporation and its affiliates disclaim any liability for any damages caused by use of this software or hardware in dangerous applications.

Oracle and Java are registered trademarks of Oracle and/or its affiliates. Other names may be trademarks of their respective owners.

Intel and Intel Xeon are trademarks or registered trademarks of Intel Corporation. All SPARC trademarks are used under license and are trademarks or registered trademarks of SPARC International, Inc. AMD, Opteron, the AMD logo, and the AMD Opteron logo are trademarks or registered trademarks of Advanced Micro Devices. UNIX is a registered trademark of The Open Group.

This software or hardware and documentation may provide access to or information about content, products, and services from third parties. Oracle Corporation and its affiliates are not responsible for and expressly disclaim all warranties of any kind with respect to third-party content, products, and services unless otherwise set forth in an applicable agreement between you and Oracle. Oracle Corporation and its affiliates will not be responsible for any loss, costs, or damages incurred due to your access to or use of third-party content, products, or services, except as set forth in an applicable agreement between you and Oracle.

Contents

Preface

| | |
|-----------------------------|-----|
| Audience | xix |
| Documentation Accessibility | xix |
| Related Documentation | xx |
| Conventions | xx |

Changes in This Release for Oracle Label Security Administrator's Guide

| | |
|---|------|
| Changes in Oracle Database 18c | xxi |
| Changes in Oracle Database 12c Release 2 (12.2) | xxii |

Part I Getting Started with Oracle Label Security

1 Introduction to Oracle Label Security

| | |
|--|-----|
| About Oracle Label Security | 1-1 |
| Benefits of Oracle Label Security | 1-2 |
| Who Has Privileges to Use Oracle Label Security? | 1-2 |
| Duties of Oracle Label Security Administrators | 1-2 |
| Components of Oracle Label Security | 1-3 |
| Oracle Label Security Architecture | 1-4 |
| Oracle Label Security Administrative Interfaces | 1-5 |
| Oracle Label Security Packages | 1-5 |
| Oracle Label Security Demonstration File | 1-6 |
| Oracle Enterprise Manager Cloud Control | 1-6 |
| How Oracle Label Security Works with Other Oracle Products | 1-7 |
| Oracle Label Security Integration with Oracle Internet Directory | 1-7 |
| Oracle Label Security Integration in a Multitenant Environment | 1-7 |

2 Understanding Data Labels and User Labels

| | |
|---|------|
| About Label-Based Security | 2-1 |
| About User Label and Privilege Management | 2-2 |
| Label Components | 2-2 |
| Label Component Definitions and Valid Characters | 2-3 |
| Level Sensitivity Components | 2-4 |
| Compartment Components | 2-5 |
| Group Components | 2-7 |
| Industry Examples of Levels, Compartments, and Groups | 2-9 |
| Label Syntax and Type | 2-9 |
| How Data Labels and User Labels Work Together | 2-10 |
| Administration of Labels | 2-12 |

3 Access Controls and Privileges

| | |
|--|------|
| Access Mediation | 3-1 |
| How the Session Label and Row Label Work | 3-2 |
| The Session Label | 3-3 |
| The Row Label | 3-3 |
| Session Label Example | 3-3 |
| How User Authorizations Work | 3-4 |
| Authorizations Set by the Administrator | 3-5 |
| Authorized Levels | 3-5 |
| Authorized Compartments | 3-6 |
| Authorized Groups | 3-6 |
| Computed Session Labels | 3-7 |
| Evaluation of Labels for Access Mediation | 3-8 |
| About Read and Write Access | 3-8 |
| Difference Between Read and Write Operations | 3-8 |
| Propagation of Read/Write Authorizations on Groups | 3-9 |
| How Oracle Label Security Algorithm for Read Access Works | 3-9 |
| How the Oracle Label Security Algorithm for Write Access Works | 3-11 |
| Oracle Label Security Privileges | 3-13 |
| Privileges Defined by Oracle Label Security Policies | 3-13 |
| Special Access Privileges | 3-14 |
| READ Privilege | 3-14 |
| FULL Privilege | 3-15 |
| COMPACCESS Privilege | 3-15 |
| PROFILE_ACCESS Privilege | 3-16 |
| Special Row Label Privileges | 3-16 |
| WRITEUP Privilege | 3-17 |

| | |
|--|------|
| WRITEDOWN Privilege | 3-17 |
| WRITEACROSS Privilege | 3-17 |
| System Privileges, Object Privileges, and Policy Privileges | 3-17 |
| Access Mediation and Views | 3-18 |
| Access Mediation and Program Unit Execution | 3-18 |
| Access Mediation and Policy Enforcement Options | 3-19 |
| Working with Multiple Oracle Label Security Policies | 3-20 |
| Multiple Oracle Label Security Policies in a Single Database | 3-20 |
| Multiple Oracle Label Security Policies in a Distributed Environment | 3-20 |

Part II Using Oracle Label Security Functionality

4 Getting Started with Oracle Label Security

| | |
|---|-----|
| Registering Oracle Label Security with an Oracle Database | 4-1 |
| About Registering Oracle Label Security | 4-1 |
| Checking if Oracle Label Security Has Been Registered and Enabled | 4-2 |
| Registering and Enabling Oracle Label Security from SQL*Plus | 4-2 |
| Registering and Enabling Oracle Label Security Using DBCA | 4-3 |
| Enabling the LBACSYS Oracle Label Security Account | 4-4 |
| Logging in to Cloud Control or SQL*Plus for Oracle Label Security | 4-5 |
| Logging in to Oracle Label Security from Enterprise Manager Cloud Control | 4-5 |
| Logging in to Oracle Label Security from SQL*Plus | 4-6 |

5 Creating an Oracle Label Security Policy

| | |
|---|------|
| About Creating Oracle Label Security Policies | 5-1 |
| Step 1: Create the Label Security Policy Container | 5-2 |
| About the Label Security Policy Container | 5-2 |
| Creating a Label Policy Container | 5-3 |
| Step 2: Create Data Labels for the Label Security Policy | 5-3 |
| About Data Labels | 5-4 |
| About Policy Level Sensitivity Components | 5-4 |
| Creating a Policy Level Component | 5-5 |
| About Policy Compartment Components | 5-6 |
| Creating a Policy Compartment Component | 5-7 |
| About Policy Group Components | 5-8 |
| Creating a Policy Data Label Group | 5-9 |
| About Associating the Policy Components with a Named Data Label | 5-10 |
| Associating the Policy Components with a Named Data Label | 5-10 |
| Step 3: Authorize Users for the Label Security Policy | 5-11 |

| | |
|---|------|
| About Authorizing Users for Label Security Policies | 5-12 |
| About Authorizing Levels | 5-12 |
| Authorizing a Level | 5-12 |
| About Authorizing Compartments | 5-13 |
| Authorizing a Compartment | 5-13 |
| About Authorizing Groups | 5-14 |
| Authorizing a Group | 5-14 |
| Step 4: Grant Privileges to Users and Trusted Stored Program Units | 5-15 |
| About Granting Privileges to Users and Trusted Program Units for the Policy | 5-15 |
| Granting Privileges to a User | 5-16 |
| Granting Privileges to a Trusted Program Unit | 5-16 |
| Step 5: Apply the Policy to a Database Table or Schema | 5-17 |
| About Applying the Policy to a Database Table or Schema | 5-17 |
| Applying a Policy to a Schema | 5-18 |
| Step 6: Add Policy Labels to Table Rows | 5-18 |
| About Adding Policy Labels to Table Rows | 5-19 |
| Adding a Policy Label to a Table Row | 5-19 |
| Step 7: (Optional) Configure Auditing | 5-19 |
| About Configuring Auditing | 5-20 |
| Configuring Auditing | 5-20 |
| Using Enterprise Manager Cloud Control to Create an OLS Policy | 5-20 |
| Creating the Label Security Policy Container Using Cloud Control | 5-21 |
| Creating Policy Components Using Cloud Control | 5-22 |
| Creating Data Labels for the Policy Using Cloud Control | 5-23 |
| Authorizing, Granting Privileges, and Auditing Users for a Policy Using Cloud Control | 5-23 |
| Granting Privileges to Trusted Program Units Using Cloud Control | 5-25 |
| Applying a Policy to a Database Table with Cloud Control | 5-26 |
| Applying Policy Labels to Table Rows Using Cloud Control | 5-27 |
| Auditing Oracle Label Security Policies Using Cloud Control | 5-27 |

6 Working with Labeled Data

| | |
|--|-----|
| How Policy Label Column and Label Tags Work | 6-1 |
| The Policy Label Column | 6-2 |
| About the Policy Label Column | 6-2 |
| Hiding the Policy Label Column | 6-2 |
| Label Tags | 6-3 |
| About Label Tags | 6-3 |
| Manually Defined Label Tags to Order Labels | 6-4 |
| Manually Defined Label Tags to Manipulate Data | 6-4 |
| Automatically Generated Label Tags | 6-5 |

| | |
|--|------|
| Assignments of Labels to Data Rows | 6-5 |
| Presenting the Label | 6-6 |
| Converting a Character String to a Label Tag with CHAR_TO_LABEL | 6-6 |
| Conversion of a Label Tag to a Character String, with LABEL_TO_CHAR | 6-6 |
| Converting a Label Tag to a Character String with LABEL_TO_CHAR | 6-7 |
| LABEL_TO_CHAR Examples | 6-7 |
| Retrieving All Columns from a Table When the Policy Label Column Is Hidden | 6-8 |
| Filtration of Data Using Labels | 6-9 |
| Use of Numeric Label Tags in WHERE Clauses | 6-9 |
| Ordering Labeled Data Rows | 6-10 |
| Ordering by Character Representation of Label | 6-10 |
| Determination of the Upper and Lower Bounds of Labels | 6-10 |
| Finding Least Upper Bound with LEAST_UBOUND | 6-11 |
| Finding Greatest Lower Bound with GREATEST_LBOUND | 6-12 |
| Merging Labels with the MERGE_LABEL Function | 6-12 |
| Inserting Labeled Data | 6-14 |
| About Inserting Labeled Data | 6-14 |
| Inserting Labels Using CHAR_TO_LABEL | 6-15 |
| Inserting Labels Using Numeric Label Tag Values | 6-15 |
| Inserting Data Without Specifying a Label | 6-15 |
| Inserting Data When the Policy Label Column Is Hidden | 6-16 |
| Inserting Labels Using TO_DATA_LABEL | 6-16 |
| Changing Session and Row Labels | 6-17 |

7 Oracle Label Security Using Oracle Internet Directory

| | |
|--|------|
| About Label Management on Oracle Internet Directory | 7-2 |
| Configuring Oracle Internet Directory-Enabled Label Security | 7-6 |
| About Configuring Oracle Internet Directory-Enabled Label Security | 7-6 |
| Granting Permissions for Configuring OID-Enabled Oracle Label Security | 7-7 |
| Registering a Database and Configuring OID-Enabled Oracle Label Security | 7-7 |
| Step 1: Configure Your Oracle Home for Directory Usage | 7-8 |
| Step 2: Configure Oracle Internet Directory for Oracle Label Security | 7-8 |
| Step 2 Alternate: Configuring Database for OID-Enabled Oracle Label Security | 7-9 |
| Step 3: Set the DIP Password and Connect Data | 7-9 |
| Unregistration of a Database with OID-Enabled Oracle Label Security | 7-10 |
| Oracle Label Security Profiles | 7-10 |
| Integrated Capabilities When Label Security Uses the Directory | 7-11 |
| Oracle Label Security Policy Attributes in Oracle Internet Directory | 7-12 |
| Subscription of Policies in Directory-Enabled Label Security | 7-13 |

| | |
|--|------|
| Restrictions on New Data Label Creation | 7-13 |
| Administrator Duties for Oracle Internet Directory and Oracle Label Security | 7-14 |
| Bootstrapping Databases | 7-14 |
| Synchronizing the Database and Oracle Internet Directory | 7-15 |
| About Synchronizing the Database and Oracle Internet Directory | 7-15 |
| Oracle Directory Integration and Provisioning (DIP) Provisioning Profiles | 7-16 |
| Modifying a Provisioning Profile | 7-17 |
| Changing the Database Connection Information for a Provisioning Profile | 7-18 |
| Configuring OID-Enabled Oracle Label Security with Oracle Data Guard | 7-19 |
| Step 1: Set Up Directory-Enabled Oracle Label Security with Data Guard | 7-19 |
| Step 2: After the Switchover, Update the OID Provisioning Profile | 7-20 |
| Security Roles and Permitted Actions | 7-21 |
| Permitted Tasks and Access Levels for Oracle Internet Directory | 7-21 |
| Restriction on Policy Creators for Directory-Enabled Oracle Label Security | 7-22 |
| Superseded PL/SQL Statements When OID Is Enabled with OLS | 7-22 |
| Oracle Label Security Procedures for Policy Administrators | 7-23 |

Part III Administering an Oracle Label Security Application

8 Implementing Policy Enforcement Options and Labeling Functions

| | |
|--|------|
| Oracle Label Security Policy Enforcement Options | 8-1 |
| About Policy Enforcement Options | 8-2 |
| Levels of Policy Enforcement Options | 8-2 |
| Categories of Policy Enforcement Options | 8-3 |
| Relationships of Policy Enforcement Options | 8-4 |
| How the HIDE Policy Column Option Works | 8-6 |
| How the Label Management Enforcement Options Work | 8-6 |
| About the Label Management Enforcement Options | 8-6 |
| LABEL_DEFAULT: Using the Session's Default Row Label | 8-7 |
| LABEL_UPDATE: Changing Data Labels | 8-7 |
| CHECK_CONTROL: Checking Data Labels | 8-7 |
| How the Access Control Enforcement Options Work | 8-8 |
| READ_CONTROL: Reading Data | 8-8 |
| WRITE_CONTROL: Writing Data | 8-8 |
| INSERT_CONTROL, UPDATE_CONTROL, and DELETE_CONTROL | 8-9 |
| How the Overriding Enforcement Options Work | 8-9 |
| Guidelines for Using the Policy Enforcement Options | 8-9 |
| Exemptions from Oracle Label Security Policy Enforcement | 8-10 |
| Data Dictionary Views for Viewing Policy Options on Tables and Schemas | 8-11 |
| Labeling Functions | 8-11 |

| | |
|--|------|
| Labeling Data Rows under Oracle Label Security | 8-11 |
| How Labeling Functions in Oracle Label Security Policies Works | 8-12 |
| Creating a Labeling Function for a Policy | 8-13 |
| Specifying a Labeling Function in a Policy | 8-14 |
| Inserting Labeled Data Using Policy Options and Labeling Functions | 8-14 |
| Outcome of Insert or Updates Operations on Data Based on Authorizations | 8-15 |
| Label Insertions When a Labeling Function Is Specified | 8-15 |
| Child Row Insertions in Tables with Declarative Referential Integrity | 8-15 |
| Updating Labeled Data Using Policy Options and Labeling Functions | 8-15 |
| Updating Labels Using CHAR_TO_LABEL | 8-16 |
| Evaluation of Enforcement Control Options and UPDATE | 8-16 |
| Updates to Labels When a Labeling Function Is Specified | 8-17 |
| Updates to Child Rows in Tables with Declarative Referential Integrity Enabled | 8-17 |
| Deletion of Labeled Data Using Policy Options and Labeling Functions | 8-18 |
| SQL Predicates with an Oracle Label Security Policy | 8-18 |
| Modifications to an Oracle Label Security Policy with a SQL Predicate | 8-19 |
| How Multiple SQL Predicates Affect Oracle Label Security Policies | 8-19 |

9 Administering and Using Trusted Stored Program Units

| | |
|---|-----|
| About Trusted Stored Program Units | 9-1 |
| How a Trusted Stored Program Unit Runs | 9-2 |
| Example: Trusted Stored Program Unit | 9-2 |
| Creating and Compiling Trusted Stored Program Units | 9-3 |
| Creation of Trusted Stored Program Units | 9-3 |
| Privileges for Trusted Stored Program Units | 9-3 |
| Recompiling of Trusted Stored Program Units | 9-4 |
| Re-creation of Trusted Stored Program Units | 9-4 |
| Execution of Trusted Stored Program Units | 9-4 |
| How Setting and Returning Label Information Works | 9-5 |

10 Auditing Under Oracle Label Security

| | |
|---|------|
| About Oracle Label Security Auditing | 10-1 |
| Systemwide Auditing: AUDIT_TRAIL Initialization Parameter | 10-2 |
| How Oracle Label Security Auditing Is Enabled or Disabled | 10-3 |
| Oracle Label Security and Unified Auditing | 10-3 |
| Oracle Label Security Auditing Tips | 10-3 |
| Strategy for Setting SA_AUDIT_ADMIN Options | 10-4 |
| Auditing of Privileged Operations | 10-4 |

11 Using Oracle Label Security with a Distributed Database

| | |
|---|-------|
| About the Oracle Label Security Distributed Configuration | 11-1 |
| How Connections to a Remote Database Under Oracle Label Security Work | 11-2 |
| Session Labels and Row Labels in Remote Sessions | 11-3 |
| Labels in a Distributed Environment | 11-4 |
| Label Tags in a Distributed Environment | 11-4 |
| Numeric Form of Label Components in a Distributed Environment | 11-5 |
| Oracle Label Security Policies in a Distributed Environment | 11-5 |
| Replication with Oracle Label Security | 11-6 |
| About Replication Under Oracle Label Security | 11-6 |
| Replication Functionality Supported by Oracle Label Security | 11-6 |
| Row-Level Security Restriction on Replication Under Oracle Label Security | 11-7 |
| Contents of a Materialized View | 11-7 |
| How Materialized View Contents Are Determined | 11-7 |
| Complete Materialized Views | 11-8 |
| Partial Materialized Views | 11-8 |
| Requirements for Creating Materialized Views Under Oracle Label Security | 11-8 |
| Requirements for a Replication Administrator | 11-9 |
| Requirements for the Owner of the Materialized View | 11-9 |
| Requirements for Creating Partial Multilevel Materialized Views | 11-10 |
| Requirements for Creating Complete Multilevel Materialized Views | 11-10 |
| How to Refresh Materialized Views | 11-10 |

12 Performing DBA Functions Under Oracle Label Security

| | |
|--|------|
| Oracle Data Pump Export Use with Oracle Label Security | 12-1 |
| Full Database Export | 12-1 |
| Schema and Table-Level Export | 12-2 |
| Data Pump Import Use with Oracle Label Security | 12-2 |
| Full Database Import for the LBACSYS Schema Metadata | 12-2 |
| Schema and Table Level Import | 12-3 |
| Requirements for Import Under Oracle Label Security | 12-3 |
| Definition of Data Labels for Import | 12-4 |
| Imports of Labeled Data Without Installing Oracle Label Security | 12-5 |
| Imports of Unlabeled Data | 12-5 |
| Importing Tables with Hidden Columns | 12-5 |
| SQL*Loader Use with Oracle Label Security | 12-5 |
| Requirements for Using SQL*Loader Under Oracle Label Security | 12-6 |
| Oracle Label Security Input to SQL*Loader | 12-6 |
| Performance Tips for Oracle Label Security | 12-7 |
| Use of ANALYZE to Improve Oracle Label Security Performance | 12-7 |

| | |
|---|-------|
| Creation of Indexes on the Policy Label Column | 12-7 |
| Label Tag Strategy Plan to Enhance Performance | 12-8 |
| Partitioned Data Based on Numeric Label Tags | 12-9 |
| Creation of Additional Databases After Installation | 12-10 |
| About the Creation of Additional Databases After Installation | 12-10 |
| Creating Additional Databases When the Label Security Schema Is in the Seed | 12-11 |
| Creating Additional Databases with the Custom Installation Option | 12-11 |
| Oracle Label Security Upgrades and Downgrades | 12-11 |
| About Oracle Label Security Upgrades and Downgrades | 12-11 |
| Oracle Label Security Upgrades | 12-12 |
| About Oracle Label Security Upgrades | 12-12 |
| Running the Oracle Label Security Preprocess Script Before Upgrading | 12-13 |
| Oracle Label Security Downgrades | 12-13 |
| About Oracle Label Security Downgrades | 12-13 |
| Running the Oracle Label Security Preprocess Script Before Downgrading | 12-14 |

13 Releasability Using Inverse Groups

| | |
|--|-------|
| About Inverse Groups and Releasability | 13-1 |
| Comparison of Standard Groups and Inverse Groups | 13-2 |
| How Inverse Groups Work | 13-3 |
| Implementation of Inverse Groups with INVERSE_GROUP Enforcement | 13-3 |
| Inverse Groups and Label Components | 13-4 |
| Computed Labels with Inverse Groups | 13-4 |
| Computed Session Labels with Inverse Groups | 13-5 |
| Inverse Groups and Computed Max Read Groups and Max Write Groups | 13-5 |
| Inverse Groups and Hierarchical Structure | 13-6 |
| Inverse Groups and User Privileges | 13-7 |
| Algorithm for Read Access with Inverse Groups | 13-7 |
| Algorithm for Write Access with Inverse Groups | 13-8 |
| Algorithms for COMPACCESS Privilege with Inverse Groups | 13-9 |
| Session Labels and Inverse Groups | 13-10 |
| Initial Session and Row Labels for Standard or Inverse Groups | 13-11 |
| About the Initial Session and Row Labels for Standard or Inverse Groups | 13-11 |
| Standard Groups: Rules for Changing Initial Session/Row Labels | 13-11 |
| Inverse Groups: Rules for Changing Initial Session/Row Labels | 13-11 |
| Setting Current Session or Row Labels for Standard or Inverse Groups | 13-12 |
| About Setting Current Session or Row Labels for Standard or Inverse Groups | 13-12 |
| Standard Groups: Rules for Changing Current Session/Row Labels | 13-12 |
| Inverse Groups: Rules for Changing Current Session/Row Labels | 13-12 |
| Examples of Session Labels and Inverse Groups | 13-13 |

| | |
|---|-------|
| Example: Simple Inverse Groups | 13-13 |
| Example: Complex Inverse Groups | 13-14 |
| Changes in Behavior of Procedures with Inverse Groups | 13-15 |
| SA_SYSDBA.CREATE_POLICY with Inverse Groups | 13-16 |
| SA_SYSDBA.ALTER_POLICY with Inverse Groups | 13-16 |
| SA_USER_ADMIN.ADD_GROUPS with Inverse Groups | 13-16 |
| SA_USER_ADMIN.ALTER_GROUPS with Inverse Groups | 13-17 |
| SA_USER_ADMIN.SET_GROUPS with Inverse Groups | 13-17 |
| SA_USER_ADMIN.SET_USER_LABELS with Inverse Groups | 13-18 |
| SA_USER_ADMIN.SET_DEFAULT_LABEL with Inverse Groups | 13-19 |
| SA_USER_ADMIN.SET_ROW_LABEL with Inverse Groups | 13-19 |
| SA_COMPONENTS.CREATE_GROUP with Inverse Groups | 13-20 |
| SA_COMPONENTS.ALTER_GROUP_PARENT with Inverse Groups | 13-20 |
| SA_SESSION.SET_LABEL with Inverse Groups | 13-20 |
| SA_SESSION.SET_ROW_LABEL with Inverse Groups | 13-20 |
| LEAST_UBOUND with Inverse Groups | 13-21 |
| GREATEST_LBOUND with Inverse Groups | 13-21 |
| Dominance Rules for Labels with Inverse Groups | 13-21 |

Part IV Appendixes

A Disabling and Enabling Oracle Label Security

| | |
|---|-----|
| When You Must Disable Oracle Label Security | A-1 |
| Disabling Oracle Label Security | A-1 |
| Enabling Oracle Label Security | A-2 |

B Advanced Topics in Oracle Label Security

| | |
|---|-----|
| Analyzing the Relationships Between Labels | B-1 |
| About Dominant and Dominated Labels | B-1 |
| Non-Comparable Labels | B-2 |
| Using Dominance Functions | B-2 |
| About the Dominance Functions | B-3 |
| OLS_DOMINATES Standalone Function | B-3 |
| OLS_LABEL_DOMINATES Standalone Function | B-4 |
| OLS_STRICTLY_DOMINATES Standalone Function | B-6 |
| OLS_DOMINATED_BY Standalone Function | B-6 |
| OLS_STRICTLY_DOMINATED_BY Standalone Function | B-7 |
| SA_UTL.DOMINATES | B-8 |
| SA_UTL.STRICTLY_DOMINATES | B-9 |

| | |
|--|------|
| SA_UTL.DOMINATED_BY | B-10 |
| SA_UTL.STRICTLY_DOMINATED_BY | B-10 |
| Queries for Audited Oracle Label Security Session Labels | B-11 |
| About Queries for Auditing Oracle Label Security Session Labels | B-11 |
| ORA_GET_AUDITED_LABEL Function | B-12 |
| Oracle Call Interface for Setting Session Labels | B-12 |
| About Using the Oracle Call Interface to Set Session Labels | B-13 |
| Using the Oracle Call Interface to Set Session Labels | B-13 |
| Example: Using Oracle Call Interface with the SYS_CONTEXT Function | B-14 |

C Command-line Tools for Label Security Using Oracle Internet Directory

| | |
|--|------|
| About the Command-line Oracle Label Security Tools | C-1 |
| Oracle Label Security Commands in Categories | C-1 |
| olsadmintool Command Reference | C-3 |
| About the olsadmintool Commands | C-5 |
| olsadmintool addadmin | C-5 |
| olsadmintool addpolcreator | C-5 |
| olsadmintool adduser | C-6 |
| olsadmintool altercompartment | C-6 |
| olsadmintool altergroup | C-6 |
| olsadmintool altergroupparent | C-7 |
| olsadmintool alterlabel | C-7 |
| olsadmintool alterlevel | C-8 |
| olsadmintool alterpolicy | C-8 |
| olsadmintool audit | C-8 |
| olsadmintool createcompartment | C-9 |
| olsadmintool creategroup | C-9 |
| olsadmintool createlabel | C-9 |
| olsadmintool createlevel | C-10 |
| olsadmintool createprofile | C-10 |
| olsadmintool createpolicy | C-11 |
| olsadmintool describeprofile | C-11 |
| olsadmintool dropadmin | C-11 |
| olsadmintool dropcompartment | C-12 |
| olsadmintool dropgroup | C-12 |
| olsadmintool droplabel | C-12 |
| olsadmintool droplevel | C-13 |
| olsadmintool droppolicy | C-13 |
| olsadmintool dropprofile | C-13 |

| | |
|--|------|
| olsadmintool droppolcreator | C-14 |
| olsadmintool dropuser | C-14 |
| olsadmintool --help | C-14 |
| olsadmintool noaudit | C-14 |
| olsadmintool listprofile | C-15 |
| Relating Parameters to Commands for olsadmintool | C-15 |
| About Relating Parameters to Commands for olsadmintool | C-15 |
| Summaries of olsadmintool Parameters | C-16 |
| Examples of Using the olsadmintool Utility | C-19 |
| Example: Making Other Users Policy Creators | C-19 |
| Example: Creating Policies with Valid Options | C-20 |
| Example: Creating Policy Administrators | C-20 |
| Example: Creating Levels | C-20 |
| Example: Creating Compartments | C-20 |
| Example: Creating Groups | C-21 |
| Example: Creating Labels | C-21 |
| Example: Creating a Profile | C-21 |
| Example: Adding a User to a Profile | C-21 |
| Example: Adding Another User to a Profile | C-22 |
| Example: Setting Audit Options | C-22 |
| Results of These Examples | C-22 |

D Oracle Label Security in an Oracle RAC Environment

| | |
|---|-----|
| Oracle Label Security Policy Functions in an Oracle RAC Environment | D-1 |
| Transparent Application Failover in Oracle Label Security | D-2 |

E Oracle Label Security PL/SQL Packages

| | |
|--|------|
| SA_AUDIT_ADMIN Oracle Label Security Auditing PL/SQL Package | E-1 |
| About the SA_AUDIT_ADMIN PL/SQL Package | E-2 |
| SA_AUDIT_ADMIN.AUDIT | E-2 |
| SA_AUDIT_ADMIN.AUDIT_LABEL | E-4 |
| SA_AUDIT_ADMIN.AUDIT_LABEL_ENABLED | E-5 |
| SA_AUDIT_ADMIN.CREATE_VIEW | E-5 |
| SA_AUDIT_ADMIN.DROP_VIEW | E-6 |
| SA_AUDIT_ADMIN.NOAUDIT | E-7 |
| SA_AUDIT_ADMIN.NOAUDIT_LABEL | E-8 |
| SA_COMPONENTS Label Components PL/SQL Package | E-9 |
| About the SA_COMPONENTS PL/SQL Package | E-10 |
| SA_COMPONENTS.ALTER_COMPARTMENT | E-10 |

| | |
|--|------|
| SA_COMPONENTS.ALTER_GROUP | E-11 |
| SA_COMPONENTS.ALTER_GROUP_PARENT | E-12 |
| SA_COMPONENTS.ALTER_LEVEL | E-13 |
| SA_COMPONENTS.CREATE_COMPARTMENT | E-14 |
| SA_COMPONENTS.CREATE_GROUP | E-15 |
| SA_COMPONENTS.CREATE_LEVEL | E-16 |
| SA_COMPONENTS.DROP_COMPARTMENT | E-17 |
| SA_COMPONENTS.DROP_GROUP | E-18 |
| SA_COMPONENTS.DROP_LEVEL | E-19 |
| SA_LABEL_ADMIN Label Management PL/SQL Package | E-20 |
| About the SA_LABEL_ADMIN PL/SQL Package | E-20 |
| SA_LABEL_ADMIN.ALTER_LABEL | E-20 |
| SA_LABEL_ADMIN.CREATE_LABEL | E-21 |
| SA_LABEL_ADMIN.DROP_LABEL | E-22 |
| SA_POLICY_ADMIN Policy Administration PL/SQL Package | E-23 |
| About the SA_POLICY_ADMIN PL/SQL Package | E-24 |
| SA_POLICY_ADMIN.ALTER_SCHEMA_POLICY | E-25 |
| SA_POLICY_ADMIN.APPLY_SCHEMA_POLICY | E-26 |
| SA_POLICY_ADMIN.APPLY_TABLE_POLICY | E-26 |
| SA_POLICY_ADMIN.DISABLE_SCHEMA_POLICY | E-27 |
| SA_POLICY_ADMIN.DISABLE_TABLE_POLICY | E-28 |
| SA_POLICY_ADMIN.ENABLE_SCHEMA_POLICY | E-29 |
| SA_POLICY_ADMIN.ENABLE_TABLE_POLICY | E-30 |
| SA_POLICY_ADMIN.POLICY_SUBSCRIBE | E-31 |
| SA_POLICY_ADMIN.POLICY_UNSUBSCRIBE | E-32 |
| SA_POLICY_ADMIN.REMOVE_SCHEMA_POLICY | E-32 |
| SA_POLICY_ADMIN.REMOVE_TABLE_POLICY | E-33 |
| SA_SESSION Session Management PL/SQL Package | E-34 |
| About the SA_SESSION PL/SQL Package | E-35 |
| SA_SESSION.COMP_READ | E-36 |
| SA_SESSION.COMP_WRITE | E-36 |
| SA_SESSION.GROUP_READ | E-37 |
| SA_SESSION.GROUP_WRITE | E-37 |
| SA_SESSION.LABEL | E-38 |
| SA_SESSION.MAX_LEVEL | E-39 |
| SA_SESSION.MAX_READ_LABEL | E-39 |
| SA_SESSION.MAX_WRITE_LABEL | E-40 |
| SA_SESSION.MIN_LEVEL | E-40 |
| SA_SESSION.MIN_WRITE_LABEL | E-41 |
| SA_SESSION.PRIVS | E-41 |
| SA_SESSION.RESTORE_DEFAULT_LABELS | E-42 |

| | |
|--|------|
| SA_SESSION.ROW_LABEL | E-42 |
| SA_SESSION.SET_LABEL | E-43 |
| SA_SESSION.SA_USER_NAME | E-44 |
| SA_SESSION.SAVE_DEFAULT_LABELS | E-44 |
| SA_SESSION.SET_ACCESS_PROFILE | E-45 |
| SA_SESSION.SET_ROW_LABEL | E-46 |
| SA_SYSDBA Policy Management PL/SQL Package | E-47 |
| About the SA_SYSDBA PL/SQL Package | E-48 |
| SA_SYSDBA.ALTER_POLICY | E-48 |
| SA_SYSDBA.CREATE_POLICY | E-49 |
| SA_SYSDBA.DISABLE_POLICY | E-50 |
| SA_SYSDBA.DROP_POLICY | E-51 |
| SA_SYSDBA.ENABLE_POLICY | E-52 |
| SA_USER_ADMIN PL/SQL Package | E-52 |
| About the SA_USER_ADMIN PL/SQL Package | E-53 |
| SA_USER_ADMIN.ADD_COMPARTMENTS | E-54 |
| SA_USER_ADMIN.ADD_GROUPS | E-55 |
| SA_USER_ADMIN.ALTER_COMPARTMENTS | E-56 |
| SA_USER_ADMIN.ALTER_GROUPS | E-57 |
| SA_USER_ADMIN.DROP_ALL_COMPARTMENTS | E-58 |
| SA_USER_ADMIN.DROP_ALL_GROUPS | E-59 |
| SA_USER_ADMIN.DROP_COMPARTMENTS | E-60 |
| SA_USER_ADMIN.DROP_GROUPS | E-60 |
| SA_USER_ADMIN.DROP_USER_ACCESS | E-61 |
| SA_USER_ADMIN.SET_COMPARTMENTS | E-62 |
| SA_USER_ADMIN.SET_DEFAULT_LABEL | E-63 |
| SA_USER_ADMIN.SET_GROUPS | E-64 |
| SA_USER_ADMIN.SET_LEVELS | E-65 |
| SA_USER_ADMIN.SET_PROG_PRIVS | E-66 |
| SA_USER_ADMIN.SET_ROW_LABEL | E-67 |
| SA_USER_ADMIN.SET_USER_LABELS | E-68 |
| SA_USER_ADMIN.SET_USER_PRIVS | E-70 |
| SA_UTL PL/SQL Utility Functions and Procedures | E-71 |
| About the SA_UTL PL/SQL Package | E-72 |
| SA_UTL.CHECK_LABEL_CHANGE | E-73 |
| SA_UTL.CHECK_READ | E-74 |
| SA_UTL.CHECK_WRITE | E-74 |
| SA_UTL.DATA_LABEL | E-75 |
| SA_UTL.GREATEST_LBOUND | E-76 |
| SA_UTL.LEAST_UBOUND | E-76 |
| SA_UTL.NUMERIC_LABEL | E-77 |

| | |
|--------------------------|------|
| SA_UTL.NUMERIC_ROW_LABEL | E-78 |
| SA_UTL.SET_LABEL | E-78 |
| SA_UTL.SET_ROW_LABEL | E-79 |

F Oracle Label Security Reference

| | |
|--|------|
| Oracle Label Security Data Dictionary Tables and Views | F-1 |
| Oracle Database Data Dictionary Tables | F-1 |
| Oracle Label Security Data Dictionary Views | F-1 |
| ALL_SA_AUDIT_OPTIONS View | F-4 |
| ALL_SA_COMPARTMENTS | F-5 |
| ALL_SA_DATA_LABELS | F-5 |
| ALL_SA_GROUPS | F-6 |
| ALL_SA_LABELS | F-6 |
| ALL_SA_LEVELS | F-7 |
| ALL_SA_POLICIES | F-7 |
| ALL_SA_PROG_PRIVS | F-8 |
| ALL_SA_SCHEMA_POLICIES | F-8 |
| ALL_SA_TABLE_POLICIES | F-9 |
| ALL_SA_USERS | F-10 |
| ALL_SA_USER_LABELS | F-11 |
| ALL_SA_USER_LEVELS | F-12 |
| ALL_SA_USER_PRIVS | F-12 |
| CDB_OLS_STATUS | F-12 |
| DBA_SA_AUDIT_OPTIONS | F-13 |
| DBA_SA_COMPARTMENTS | F-13 |
| DBA_SA_DATA_LABELS | F-13 |
| DBA_SA_GROUPS | F-14 |
| DBA_SA_GROUP_HIERARCHY | F-14 |
| DBA_SA_LABELS | F-15 |
| DBA_SA_LEVELS | F-15 |
| DBA_SA_POLICIES | F-15 |
| DBA_SA_PROG_PRIVS | F-16 |
| DBA_SA_SCHEMA_POLICIES | F-16 |
| DBA_SA_TABLE_POLICIES | F-16 |
| DBA_SA_USERS | F-16 |
| DBA_SA_USER_COMPARTMENTS | F-17 |
| DBA_SA_USER_GROUPS | F-17 |
| DBA_SA_USER_LABELS | F-18 |
| DBA_SA_USER_LEVELS | F-18 |
| DBA_SA_USER_PRIVS | F-18 |

| | |
|--|------|
| DBA_OLS_STATUS | F-18 |
| USER_SA_SESSION | F-19 |
| Oracle Label Security User-Created Auditing View | F-20 |
| Restrictions in Oracle Label Security | F-21 |

G Frequently Asked Questions about Oracle Label Security

| | |
|---|-----|
| Who Uses Oracle Label Security? | G-1 |
| How Can Oracle Label Security Address My Security Needs? | G-2 |
| Should I Use Oracle Label Security to Protect All My Tables? | G-2 |
| What Is the Difference Between Oracle Virtual Private Database and Oracle Label Security? | G-2 |
| Can I Combine Oracle Virtual Private Database and Oracle Label Security? | G-3 |
| Can I Use Oracle Label Security with Oracle E-Business Suite? | G-3 |
| Can I Use Oracle Label Security with Oracle Database Vault? | G-3 |
| Does Oracle Label Security Provide Column-Level Access Control? | G-4 |
| Can I Base Secure Application Roles on Oracle Label Security? | G-4 |
| What Are Trusted Stored Program Units? | G-4 |
| Does VPD or OLS Add an Additional Column to the Protected Table? | G-5 |
| Why Should the Additional OLS Row Label Column Be Hidden? | G-5 |

Index

Preface

Oracle Label Security enables access control to reach specific (labeled) rows of a database. With Oracle Label Security in place, users with varying privilege levels automatically have (or are excluded from) the right to see or alter labeled rows of data.

Oracle Label Security Administrator's Guide describes how to use Oracle Label Security to protect sensitive data. It explains the basic concepts behind label-based security and provides examples to show how it is used.

- [Audience](#)
- [Documentation Accessibility](#)
- [Related Documentation](#)
- [Conventions](#)

Audience

Oracle Label Security Administrator's Guide is intended for database administrators (DBAs), application programmers, security administrators, system operators, and other Oracle users who perform the following tasks:

- Analyze application security requirements
- Create label-based security policies
- Administer label-based security policies
- Use label-based security policies

To use this document, you need a working knowledge of SQL and Oracle fundamentals. You should also be familiar with Oracle security features described in [Related Documentation](#). To use SQL*Loader, you must know how to use the file management facilities of your operating system.

Documentation Accessibility

For information about Oracle's commitment to accessibility, visit the Oracle Accessibility Program website at <http://www.oracle.com/pls/topic/lookup?ctx=acc&id=docacc>.

Access to Oracle Support

Oracle customers that have purchased support have access to electronic support through My Oracle Support. For information, visit <http://www.oracle.com/pls/topic/lookup?ctx=acc&id=info> or visit <http://www.oracle.com/pls/topic/lookup?ctx=acc&id=trs> if you are hearing impaired.

Related Documentation

For more information, see these Oracle resources:

- *Oracle Database Concepts*
- *Oracle Database Security Guide*
- *Oracle Database 2 Day + Security Guide*
- *Oracle Database Enterprise User Security Administrator's Guide*
- *Oracle Database Development Guide*
- *Oracle Database Administrator's Guide*
- *Oracle Database SQL Language Reference*
- *Oracle Database Reference*
- *Oracle Database Utilities*
- *Oracle Database Performance Tuning Guide*

Many of the examples in this book use the sample schemas, which are installed by default when you select the Basic Installation option with an Oracle Database installation. See *Oracle Database Sample Schemas* for information on how these schemas were created and how you can use them yourself.

To download free release notes, installation documentation, white papers, or other collateral, please visit the Oracle Technology Network (OTN) at

<http://www.oracle.com/technetwork/index.html>

For the latest version of the Oracle documentation, including this guide, visit

<http://www.oracle.com/technetwork/documentation/index.html>

Conventions

The following text conventions are used in this document:

| Convention | Meaning |
|-----------------|--|
| boldface | Boldface type indicates graphical user interface elements associated with an action, or terms defined in text or the glossary. |
| <i>italic</i> | Italic type indicates book titles, emphasis, or placeholder variables for which you supply particular values. |
| monospace | Monospace type indicates commands within a paragraph, URLs, code in examples, text that appears on the screen, or text that you enter. |

Changes in This Release for Oracle Label Security Administrator's Guide

This preface contains:

- [Changes in Oracle Database 18c](#)
- [Changes in Oracle Database 12c Release 2 \(12.2\)](#)

Changes in Oracle Database 18c

The following are changes in *Oracle Label Security Administrator's Guide* for Oracle Database 18c.

- [LBACSYS User Created by Default as a Schema Only Account](#)
Starting with this release, the `LBACSYS` user account is create as a schema only account.
- [Deprecated Columns in Oracle Label Security Views](#)
Starting in this release, four Oracle Label Security data dictionary views have deprecated columns.

LBACSYS User Created by Default as a Schema Only Account

Starting with this release, the `LBACSYS` user account is create as a schema only account.

Users cannot login to a schema only account until an authentication method is configured for the account by using the `ALTER USER` statement. `LBACSYS` is only used as a login account initially to provision named Oracle Label Security administrators. Because users do not need to log in to this account (except for initial provisioning), `LBACSYS` should remain a schema only account so that default passwords do not need to be changed or rotated.

This feature meets requirements for users who must be able to create schemas for object ownership without actually allowing the schema owner to log in to the database. Examples of environments that have this need include some Oracle schemas as well as some customer schemas.

Related Topics

- [Enabling the LBACSYS Oracle Label Security Account](#)
After you complete the registration process, the default user account, `LBACSYS`, is granted the `LBAC_DBA` database role, which provides the privileges necessary to manage Oracle Label Security.
- *Oracle Database Security Guide*

Deprecated Columns in Oracle Label Security Views

Starting in this release, four Oracle Label Security data dictionary views have deprecated columns.

| Data Dictionary View | Deprecated Column |
|----------------------|-------------------|
| ALL_SA_USER_LABELS | LABELS |
| ALL_SA_USERS | USER_LABELS |
| DBA_SA_USER_LABELS | LABELS |
| DBA_SA_USERS | USER_LABELS |

The information in the `LABELS` and `USER_LABELS` columns is redundant. This information is displayed in other columns in these data dictionary views.

Related Topics

- [Oracle Label Security Data Dictionary Views](#)
Oracle Label Security maintains an independent set of data dictionary views, which are exempt from any policy enforcement.

Changes in Oracle Database 12c Release 2 (12.2)

The following are changes in *Oracle Label Security Administrator's Guide* for Oracle Database 12c release 2 (12.2).

- [New Features](#)

New Features

This section contains:

- [Oracle Label Security Support for Oracle Database Real Application Security Users](#)
Starting with this release, Oracle Label Security provides support for the Oracle Database Real Application Security user account.
- [Oracle Label Security Support for Data Guard Rolling Upgrades](#)
Oracle Label Security now supports rolling upgrades for Oracle Data Guard.
- [Enhancements for Oracle Label Security in a Multitenant Environment](#)
Starting with this release, Oracle Label Security supports the use of Oracle Label Security policies in application containers.

Oracle Label Security Support for Oracle Database Real Application Security Users

Starting with this release, Oracle Label Security provides support for the Oracle Database Real Application Security user account.

This feature enables Oracle Label Security policies to be enforced for Real Application Security users by assigning labels and privileges to Real Application Security users.

To configure the Oracle Database Real Application Security user for Oracle Label Security, you can set the `user_name` parameter in the `SA_USER_ADMIN.SET_USER_LABELS` procedure and in the `SA_USER_ADMIN.SET_USER_PRIVS` procedure.

Related Topics

- [SA_USER_ADMIN.SET_USER_LABELS](#)
The `SA_USER_ADMIN.SET_USER_LABELS` procedure sets the user's levels, compartments, and groups using a set of labels, instead of the individual components.
- [SA_USER_ADMIN.SET_USER_PRIVS](#)
The `SA_USER_ADMIN.SET_USER_PRIVS` procedure sets policy-specific privileges for users.

Oracle Label Security Support for Data Guard Rolling Upgrades

Oracle Label Security now supports rolling upgrades for Oracle Data Guard.

You can perform Oracle Data Guard rolling upgrades to new database releases or patch sets in a rolling fashion, which reduces the planned downtime. The total database downtime for a rolling upgrade is limited to the small amount of time that is required to execute an Oracle Data Guard switchover operation.

See Also:

Oracle Data Guard Concepts and Administration for more information about Oracle Data Guard rolling upgrades

Enhancements for Oracle Label Security in a Multitenant Environment

Starting with this release, Oracle Label Security supports the use of Oracle Label Security policies in application containers.

In addition to application container support, there are changes in how you can use Oracle Label Security in a CDB environment. As part of this enhancement, you can query the `CDB_OLS_STATUS` to check the enablement status of Oracle Label Security in a multitenant environment.

Related Topics

- [Oracle Label Security Integration in a Multitenant Environment](#)
You can use Oracle Label Security in a multitenant environment.
- [CDB_OLS_STATUS](#)
The `CDB_OLS_STATUS` data dictionary view shows the configuration status of Oracle Label Security in the database in a multitenant environment.

Part I

Getting Started with Oracle Label Security

Part I introduces the terms, concepts, and relationships that constitute the basic elements of Oracle Label Security.

- [Introduction to Oracle Label Security](#)
Oracle Label Security provides fine-grained access to individual table rows.
- [Understanding Data Labels and User Labels](#)
You should understand fundamental concepts of data labels and user labels.
- [Access Controls and Privileges](#)
Oracle provides access controls and privileges that determine the *type* of access users can have to labeled rows.

1

Introduction to Oracle Label Security

Oracle Label Security provides fine-grained access to individual table rows.

- [About Oracle Label Security](#)
Oracle Label Security controls the display of individual table rows using labels that are assigned to individual table rows and application users.
- [Benefits of Oracle Label Security](#)
Oracle Label Security provides several benefits for controlling row level management.
- [Who Has Privileges to Use Oracle Label Security?](#)
When you register Oracle Label Security with a database, the registration process creates an administrative user named `LBACSYS`, who has the `LBAC_DBA` role.
- [Duties of Oracle Label Security Administrators](#)
Oracle Label Security administrators have a set of package- and role-based privileges.
- [Components of Oracle Label Security](#)
An Oracle Label Security policy has a standard set of components.
- [Oracle Label Security Architecture](#)
The Oracle Label Security works with Oracle Database authentication to perform row level security.
- [Oracle Label Security Administrative Interfaces](#)
You can perform Oracle Label Security development and administrative tasks using either of two interfaces.
- [How Oracle Label Security Works with Other Oracle Products](#)
You can integrate Oracle Label Security with Oracle Internet Directory (OID) and in a multitenant environment.

About Oracle Label Security

Oracle Label Security controls the display of individual table rows using labels that are assigned to individual table rows and application users.

Oracle Label Security is based on multi-level security (MLS) requirements that are found in government and defense organizations. You can easily restrict sensitive information to only authorized users. Oracle Label Security is based on Oracle Virtual Private Database (VPD). However, unlike VPD, Oracle Label Security provides the access mediation functions, data dictionary tables, and policy based architecture out of the box, eliminating customized coding and providing a consistent label based access control model that can be used by multiple applications. Oracle Label Security policies can be applied to one or more application tables. Oracle Label Security works by comparing the row label with a user's label authorizations. Oracle Label Security software is installed by default, but not automatically enabled. You can easily enable Oracle Label Security in either SQL*Plus or by using the Oracle Database Configuration Assistant (DBCA). To manage Oracle Label Security, you can use either Oracle Enterprise Manager Cloud Control or a set of PL/SQL packages and

standalone functions at the command line level. The default administrator for Oracle Label Security is the user `LBACSYS`. To find information about Oracle Label Security policies, you can query `ALL_SA_*`, `DBA_SA_*`, or `USER_SA_*` data dictionary views.

Benefits of Oracle Label Security

Oracle Label Security provides several benefits for controlling row level management.

- It enables row level data classification and provides out of the box access mediation based on the data classification and the user label authorization or security clearance.
- It enables you to assign label authorizations or security clearances to both database users and application users.
- It provides both a graphical user interface and APIs for defining and storing data classification labels and user label authorizations.
- It integrates with Oracle Database Vault and Oracle Advanced Security Data Redaction, enabling security clearances to be use in both Database Vault command rules and Data Redaction policy definitions.

Who Has Privileges to Use Oracle Label Security?

When you register Oracle Label Security with a database, the registration process creates an administrative user named `LBACSYS`, who has the `LBAC_DBA` role.

You can grant this role to any database user who will be responsible for managing Oracle Label Security policies. In addition, you can grant Oracle Label Security administrators the `EXECUTE` privilege for the Oracle Label Security packages, and privileges to manage individual Oracle Label Security policies.

Duties of Oracle Label Security Administrators

Oracle Label Security administrators have a set of package- and role-based privileges.

These privileges are:

- **Package-specific privileges:** Most of the Oracle Label Security PL/SQL packages, except for the public `SA_SESSION` and `SA_UTL` packages, require the `EXECUTE` privilege.
- **Role-based privileges:** The Oracle Label Security-specific roles are:
 - The `policy_DBA` role, which is created and granted to the user when he or she creates a policy. For example, for a policy named `ols_hr_pol`, the role created is named `ols_hr_pol_DBA`. This role adds a layer of granularity for access control for your site's Oracle Label Security policies.
 - The `LBAC_DBA` role, which provides the `EXECUTE` privilege for the `SA_SYSDBA` package. This role is owned by the `LBACSYS` user account. The `SA_SYSDBA` package enables the user to create, alter, enable, disable, and drop Oracle Label Security policies.

You can use the Oracle Label Security package `EXECUTE` privilege grants along with grants of the `policy_DBA` role to achieve additional separation of duty. The packages are categorized based on different tasks. For example, you could grant the `EXECUTE`

privilege on the `SA_COMPONENTS` and `SA_LABEL_ADMIN` packages to one user or role to manage label definitions, and then grant `EXECUTE` on `SA_USER_ADMIN` to a different user or role to manage user labels and privileges. Both of these users or roles must also be granted the `policy_DBA` role for the policies for which they are responsible. In this way, different users can be responsible for the management of different aspects of the policies for which they are responsible. For example, user `psmith` could be responsible for the label definitions of the `ols_hr_pol` policy, and user `tjones` could be responsible for the label definitions of the `ols_oe_pol` policy. However, user `psmith` cannot modify label definitions for the `ols_oe_pol` policy, nor can `tjones` modify the `ols_hr_pol` policy label definitions.

Related Topics

- [Oracle Label Security Packages](#)
Oracle Label Security packages provide a direct, command-line interface for ease of administration.

Components of Oracle Label Security

An Oracle Label Security policy has a standard set of components.

These components are as follows:

- **Labels.** Labels for data and users, along with authorizations for users and program units, govern access to specified protected objects. Labels are composed of the following:
 - **Levels.** Levels indicate the type of sensitivity that you want to assign to the row, for example, `SENSITIVE` or `HIGHLY SENSITIVE`.
 - **Compartments.** (Optional) Data can have the same level (Public, Confidential and Secret), but can belong to different projects inside a company, for example ACME Merger and IT Security. Compartments represent the projects in this example, that help define more precise access controls. They are most often used in government environments.
 - **Groups.** (Optional) Groups identify organizations owning or accessing the data, for example, UK, US, Asia, Europe. Groups are used both in commercial and government environments, and frequently used in place of compartments due to their flexibility.
- **Policy.** A policy is a name associated with these labels, rules, authorizations, and protected tables.

For example, assume that a user has the `SELECT` privilege on an application table. As illustrated in [Figure 1-1](#), when the user runs a `SELECT` statement, Oracle Label Security evaluates each row selected to determine whether the user can access using the privileges and labels assigned to the user and the label on the row. You can configure Oracle Label Security to perform security checks on `UPDATE`, `DELETE`, and `INSERT` statements as well.

Figure 1-1 Oracle Label Security Label-Based Security

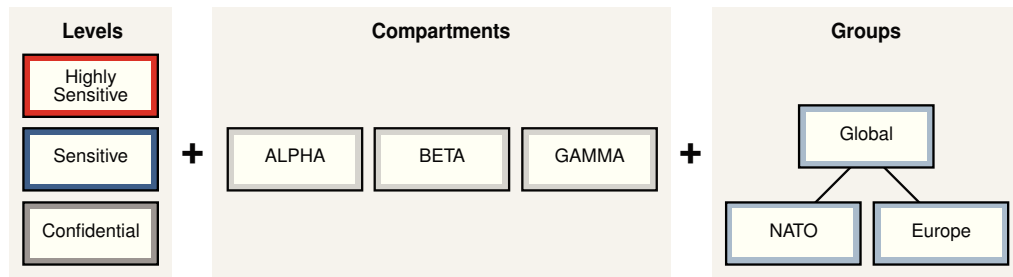

Oracle Label Security Architecture

The Oracle Label Security works with Oracle Database authentication to perform row level security.

Figure 1-2 shows how data is accessed under Oracle Label Security and the sequence of label security checks.

Figure 1-2 Oracle Label Security Architecture

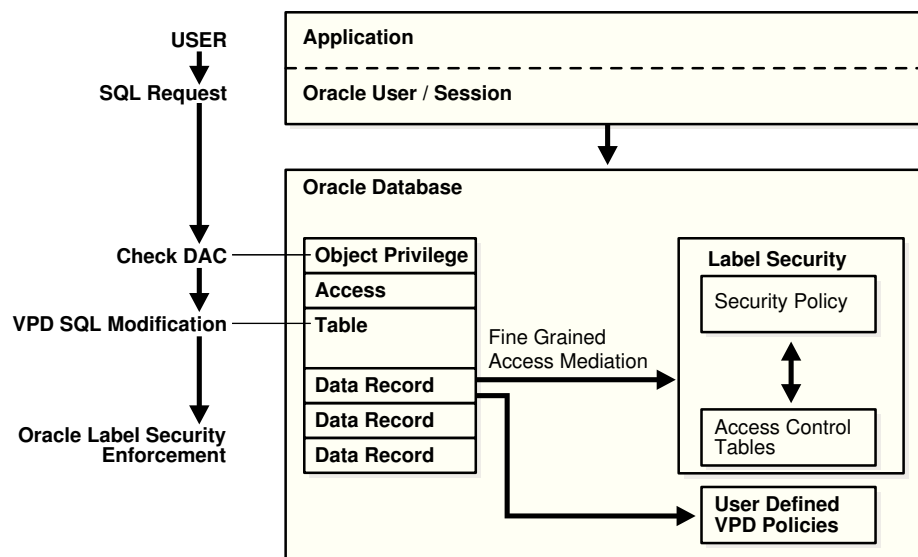

In this scenario, the following actions take place:

1. An application user in an Oracle Database session sends a SQL request to query a table.
2. Oracle Database checks the user's data access control (DAC) privileges for performing a `SELECT` statement on the table.
3. If the user does have the appropriate privileges, then Oracle Database checks if there are any Oracle Virtual Private Database (VPD) policies attached to the table.
4. Oracle Database then checks if there are any Oracle Label Security policies that are assigned to the table.

5. Oracle Label Security then compares the labels that are assigned to individual rows with the users' label authorizations, allowing or denying access. The session label is based on label authorizations that are assigned to the user.

Oracle Label Security Administrative Interfaces

You can perform Oracle Label Security development and administrative tasks using either of two interfaces.

- [Oracle Label Security Packages](#)
Oracle Label Security packages provide a direct, command-line interface for ease of administration.
- [Oracle Label Security Demonstration File](#)
The `olsdemo.sql` file provides a demonstration on using Oracle Label Security.
- [Oracle Enterprise Manager Cloud Control](#)
The Oracle Enterprise Manager Cloud Control Web interface can be used to administer Oracle Label Security.

Oracle Label Security Packages

Oracle Label Security packages provide a direct, command-line interface for ease of administration.

[Table 1-1](#) lists the available Oracle Label Security administrative packages.

Table 1-1 Oracle Label Security Administrative Packages

| Package | Purpose |
|-----------------|--|
| SA_SYSDBA | To create, alter, and drop Oracle Label Security policies See SA_SYSDBA Policy Management PL/SQL Package |
| SA_COMPONENTS | To define the levels, compartments, and groups for the policy See SA_COMPONENTS Label Components PL/SQL Package |
| SA_LABEL_ADMIN | To perform standard label policy administrative functions, such as creating labels See SA_LABEL_ADMIN Label Management PL/SQL Package |
| SA_POLICY_ADMIN | To apply policies to schemas and tables See SA_POLICY_ADMIN Policy Administration PL/SQL Package |
| SA_USER_ADMIN | To manage user authorizations for levels, compartments, and groups, as well as program unit privileges. Also to administer user privileges. See SA_USER_ADMIN.SET_USER_PRIVS and SA_USER_ADMIN.SET_PROG_PRIVS |
| SA_AUDIT_ADMIN | To set options to audit administrative tasks and use of privileges See SA_AUDIT_ADMIN Oracle Label Security Auditing PL/SQL Package |
| SA_SESSION | To change labels during a session within the authorizations set by the administrator See SA_SESSION Session Management PL/SQL Package |

Table 1-1 (Cont.) Oracle Label Security Administrative Packages

| Package | Purpose |
|---------|---|
| SA_UTL | A set of utility functions designed for use within PL/SQL programs to return information about the current values of the session security attributes, as numeric label values See SA_UTL PL/SQL Utility Functions and Procedures |

Oracle Label Security Demonstration File

The `olsdemo.sql` file provides a demonstration on using Oracle Label Security.

This file show to create and develop an Oracle Label Security policy using the supplied packages. You can install this script from the `ORACLE_HOME/rdbms/demo` directory.

Oracle Enterprise Manager Cloud Control

The Oracle Enterprise Manager Cloud Control Web interface can be used to administer Oracle Label Security.

[Figure 1-3](#) illustrates the Oracle Enterprise Manager interface.

Figure 1-3 Using Enterprise Manager to Configure Oracle Label Security Policies

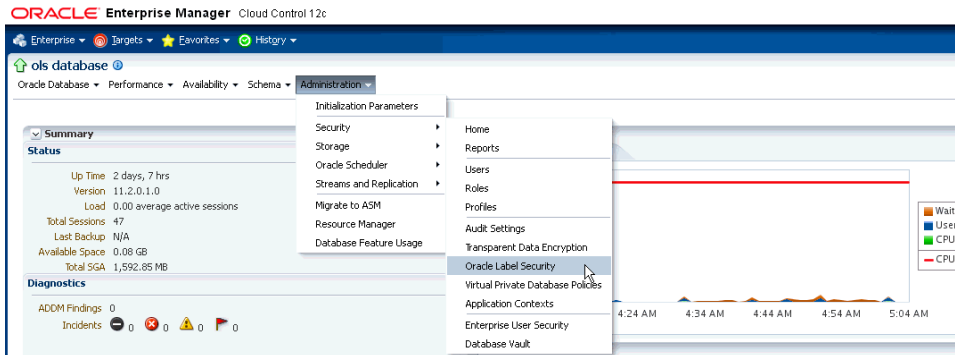

Related Topics

- [Logging in to Cloud Control or SQL*Plus for Oracle Label Security](#)
After you complete the Oracle Label Security registration and enablement process, you can begin using it.
- [Getting Started with Oracle Label Security](#)
Before using Oracle Label Security, you must register it with the database and then enable the `LBACSYS` Oracle Label Security account.

How Oracle Label Security Works with Other Oracle Products

You can integrate Oracle Label Security with Oracle Internet Directory (OID) and in a multitenant environment.

- [Oracle Label Security Integration with Oracle Internet Directory](#)
Sites that integrate their use of Oracle Label Security with Oracle Internet Directory gain significant efficiencies of label security operation and administration.
- [Oracle Label Security Integration in a Multitenant Environment](#)
You can use Oracle Label Security in a multitenant environment.

Oracle Label Security Integration with Oracle Internet Directory

Sites that integrate their use of Oracle Label Security with Oracle Internet Directory gain significant efficiencies of label security operation and administration.

You can create and manage directly policies and user authorization profiles in the directory by means of the commands that are described in [Command-line Tools for Label Security Using Oracle Internet Directory](#). Changes are automatically propagated to the associated directories.

A complete introduction to this integration is presented in [Oracle Label Security Using Oracle Internet Directory](#).

Oracle Label Security Integration in a Multitenant Environment

You can use Oracle Label Security in a multitenant environment.

In a multitenant environment, pluggable databases (PDBs) can be plugged in and out of a multitenant container database (CDB) or an application container.

Note the following:

- Each PDB has its own Oracle Label Security metadata, such as policies, labels, and user authorizations. The `LBACSYS` schema is a common user schema. See [Enabling the LBACSYS Oracle Label Security Account](#) for more information about the `LBACSYS` account.
- Before you plug a PDB into a CDB, if the database does not have Oracle Label Security installed, then ensure that you have run the `$ORACLE_HOME/rdbms/admin/catols.sql` script on the database. See *Oracle Database Administrator's Guide* for more information about creating CDBs.
- Because Oracle Label Security policies are scoped to individual PDBs, you can create individual policies for each PDB. A policy defined for a PDB can be enforced on the local tables and schema objects contained in the PDB.
- In a single CDB, there can be multiple PDBs, each configured with Oracle Label Security.
- You cannot create Oracle Label Security policies in the CDB root or the application root.

- You cannot enforce a local Oracle Label Security policy on a common CDB object or a common application object.
- You cannot assign Oracle Label Security policy labels and privileges to common users and application common users in a pluggable database.
- You cannot assign Oracle Label Security privileges to common procedures or functions and application common procedures or functions in a pluggable database.
- If you are configuring Oracle Label Security with Oracle Internet Directory, be aware that the same configuration must be used throughout with all PDBs contained in the CDB. You can determine if your database is configured for Oracle Internet Directory by querying the `DBA_OLS_STATUS` data dictionary view as follows from within any PDB:

```
SELECT STATUS FROM DBA_OLS_STATUS WHERE NAME = 'OLS_DIRECTORY_STATUS';
```

If it returns `TRUE`, then Oracle Label Security is Internet Directory-enabled. Otherwise, it returns `FALSE`.

See Also:

- *Oracle Database Security Guide* for information on how the multitenant architecture affects privileges
- [Oracle Label Security Integration with Oracle Internet Directory](#) for information about Internet Directory-enabled Oracle Label Security

2

Understanding Data Labels and User Labels

You should understand fundamental concepts of data labels and user labels.

- [About Label-Based Security](#)
Label-based security provides a flexible way of controlling access to sensitive data.
- [About User Label and Privilege Management](#)
To manage user labels and privileges, you must have the `EXECUTE` privilege for the `SA_USER_ADMIN` package and the `policy_DBA` role.
- [Label Components](#)
You should understand the elements that are used in labels.
- [Label Syntax and Type](#)
After label components are defined, you can create data labels by combining particular sets of level, compartments, and groups.
- [How Data Labels and User Labels Work Together](#)
A user can access data only within the range of his or her own label authorizations.
- [Administration of Labels](#)
Oracle Label Security provides administrative interfaces to define and manage the labels used in a database.

About Label-Based Security

Label-based security provides a flexible way of controlling access to sensitive data.

Oracle Label Security controls data access based on the identity and label of the user, and the sensitivity and label of the data. Label security adds protections beyond the discretionary access controls that determine the operations users can perform upon data in an *object*, such as a table or view.

[Table 2-1](#) shows the three dimensions with which an Oracle Label Security policy controls access to data.

Table 2-1 Oracle Label Security Data Dimensions

| Data Dimension | Explanation |
|----------------|--|
| Data Labels | A data row label indicates the level and nature of the row's sensitivity and specifies the additional criteria that a user must meet to gain access to that row. |

Table 2-1 (Cont.) Oracle Label Security Data Dimensions

| Data Dimension | Explanation |
|-------------------|--|
| User Labels | A user label specifies that user's sensitivity level plus any compartments and groups that constrain the user's access to labeled data. Each user is assigned a range of levels, compartments, and groups, and each session can operate within that authorized range to access labeled data within that range. |
| Policy Privileges | Users can be given specific rights (privileges) to perform special operations or to access data beyond their label authorizations. |

Note that the discussion here concerns access to data. The particular *type* of access, such as reading or writing the data, is covered in [Access Controls and Privileges](#).

When an Oracle Label Security policy is applied to a database table, a column is added to the table to contain each row's label. The administrator can choose to display or hide this column.

About User Label and Privilege Management

To manage user labels and privileges, you must have the `EXECUTE` privilege for the `SA_USER_ADMIN` package and the `policy_DBA` role.

The `SA_USER_ADMIN` package provides the functions to manage the Oracle Label Security user security attributes. It contains several procedures to manage user labels by component: that is, specifying user levels, compartments, and groups. For convenience, there are additional procedures that accept character string representations of full labels, rather than components. Note that the level, compartment and group parameters use the short name defined for each component.

All of the label and privilege information is stored in Oracle Label Security data dictionary tables. When a user connects to the database, his session labels are established based on the information stored in the Oracle Label Security data dictionary.

Note that a user can be authorized under multiple policies.

Related Topics

- [SA_USER_ADMIN PL/SQL Package](#)
The `SA_USER_ADMIN` PL/SQL package manages user labels by label component.
- [SA_USER_ADMIN.SET_USER_PRIVS](#)
The `SA_USER_ADMIN.SET_USER_PRIVS` procedure sets policy-specific privileges for users.
- [Duties of Oracle Label Security Administrators](#)
Oracle Label Security administrators have a set of package- and role-based privileges.

Label Components

You should understand the elements that are used in labels.

- [Label Component Definitions and Valid Characters](#)
A sensitivity label is a single attribute with multiple components.
- [Level Sensitivity Components](#)
A *level* is a ranking that denotes the sensitivity of the information it labels.
- [Compartment Components](#)
Compartments identify areas that describe the sensitivity of the labeled data, providing a finer level of granularity within a level.
- [Group Components](#)
Groups identify organizations owning or accessing the data, such as EASTERN_REGION, WESTERN_REGION, WR_SALES.
- [Industry Examples of Levels, Compartments, and Groups](#)
Oracle Label Security levels, compartments, groups are designed to be implemented in various industries.

Label Component Definitions and Valid Characters

A sensitivity label is a single attribute with multiple components.

All data labels must contain a level component, but the compartment and group components are optional. An administrator must define the label components before creating labels.

Note:

Although the administrator defines both long and short names for the label components, only the short form of the name is displayed upon retrieval. When users manipulate the labels, they use only the short form of the component names. Examples of short forms are illustrated in component-specific example tables below.

Table 2-2 Sensitivity Label Components

| Component | Description | Examples |
|--------------|--|---|
| Level | A single specification of the sensitivity of labeled data within the ordered ranks established | CONFIDENTIAL (1), SENSITIVE (2), HIGHLY_SENSITIVE (3) |
| Compartments | Zero or more categories associated with the labeled data | FINANCIAL, STRATEGIC, NUCLEAR |
| Groups | Zero or more identifiers for organizations owning or accessing the data | EASTERN_REGION, WESTERN_REGION |

Valid characters for specifying all label components include alphanumeric characters, underscores, and spaces. (Leading and trailing spaces are ignored.)

The following figure illustrates the three dimensions in which data can be logically classified, using levels, compartments, and groups.

Figure 2-1 Data Categorization with Levels, Compartments and Groups

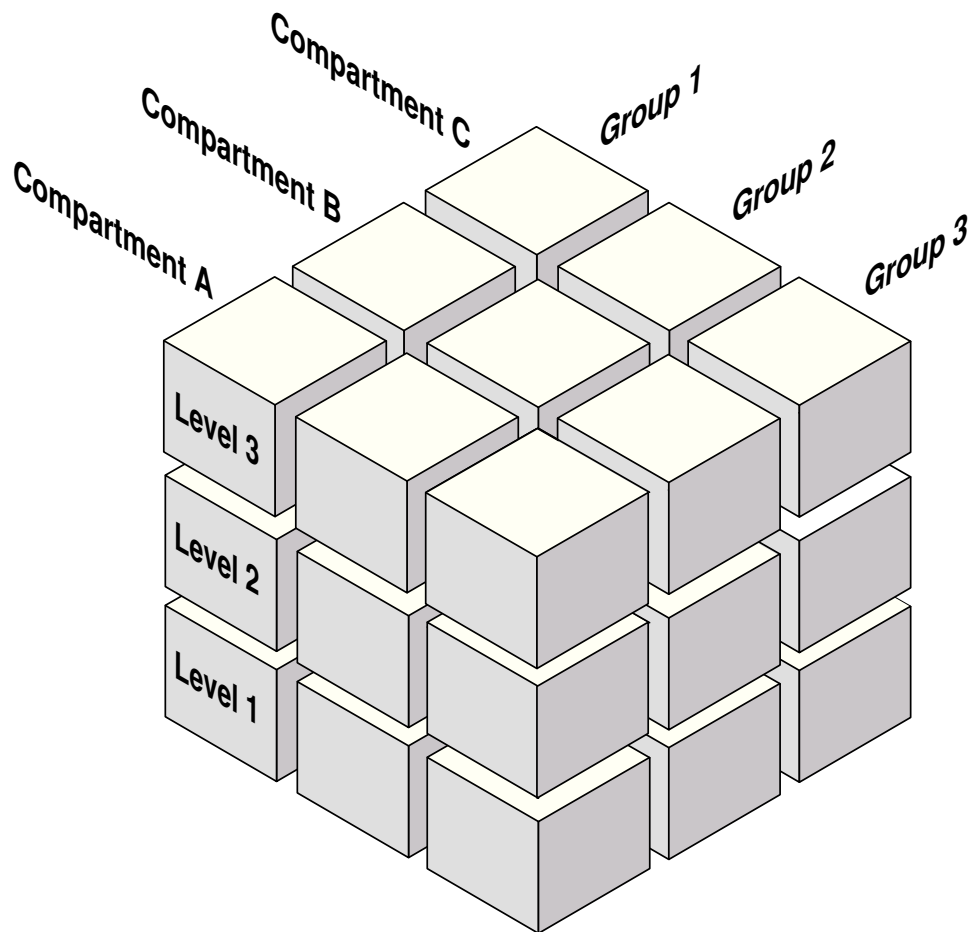

Level Sensitivity Components

A *level* is a ranking that denotes the sensitivity of the information it labels.

The more sensitive the information, the higher its level. The less sensitive the information, the lower its level.

The more sensitive the information, the higher its level. The less sensitive the information, the lower its level.

Every label must include one level. Oracle Label Security permits defining up to 10,000 levels in a policy. For each level, the Oracle Label Security administrator defines a numeric form, a long character form, and the required short character form.

For example, you can define a set of levels such as the following'

[Table 2-2](#) shows examples of levels.

Table 2-3 Level Example

| Numeric Form | Long Form | Short Form |
|--------------|------------------|------------|
| 40 | HIGHLY_SENSITIVE | HS |
| 30 | SENSITIVE | S |
| 20 | CONFIDENTIAL | C |
| 10 | PUBLIC | P |

Table 2-4 shows different ways of specifying levels.

Table 2-4 Forms of Specifying Levels

| Form | Explanation |
|---------------------------------|--|
| Numeric form, also called "tag" | The numeric form of the level can range from 0 to 9999. Sensitivity is ranked by this numeric value, so you must assign higher numbers to levels that are more sensitive, and lower numbers to levels that are less sensitive. In Table 2-3, 40 (HIGHLY_SENSITIVE) is a higher level than 30, 20, and 10. Administrators should avoid using sequential numbers for the numeric form of levels. A good strategy is to use even increments (such as 50 or 100) between levels. You can then insert additional levels between two preexisting levels, at a later date. |
| Long form | The long form of the level name can contain up to 80 characters. |
| Short form | The short form can contain up to 30 characters. |

Although the administrator defines both long and short names for the level (and for each of the other label components), only the short form of the name is displayed upon retrieval of the records when the Oracle Label Security policy is in effect. When users manipulate the labels, they use only the short form of the component names.

Other sets of levels that users commonly define include TOP_SECRET, SECRET, CONFIDENTIAL, and UNCLASSIFIED or TRADE_SECRET, PROPRIETARY, COMPANY_CONFIDENTIAL, PUBLIC_DOMAIN.

If only levels are used, a level 40 user (in this example) can access or alter any data row whose level is 40 or less.

 **Note:**

All levels and labels (including TOP_SECRET, SECRET, CONFIDENTIAL, and so on) in this guide, are used as illustrations only.

Compartment Components

Compartments identify areas that describe the sensitivity of the labeled data, providing a finer level of granularity within a level.

Compartments associate the data with one or more security areas. All data related to a particular project can be labeled with the same compartment. For example, you can define a set of compartments like the following.

Table 2-5 shows examples of compartments.

Table 2-5 Compartment Example

| Numeric Form | Long Form | Short Form |
|--------------|-------------|------------|
| 85 | FINANCIAL | FINCL |
| 65 | CHEMICAL | CHEM |
| 45 | OPERATIONAL | OP |

Table 2-6 shows different ways of specifying compartments.

Table 2-6 Forms of Specifying Compartments

| Form | Explanation |
|--------------|--|
| Numeric form | <p>The numeric form can range from 0 to 9999. It is unrelated to the numbers used for the levels. The numeric form of the compartment does not indicate greater or less sensitivity. Instead, it controls the display order of the short form compartment name in the label character string. For example, assume a label is created that has all three compartments listed in Table 2-5, and a level of <code>SENSITIVE</code>. When this label is displayed in string format, it looks like this:</p> <pre>S:OP,CHEM,FINCL</pre> <p>meaning <code>SENSITIVE: OPERATIONAL, CHEMICAL, FINANCIAL</code></p> <p>The display order follows the order of the numbers assigned to the compartments: 45 is lower than 65, and 65 is lower than 85. By contrast, if the number assigned to the <code>FINCL</code> compartment were 5, the character string format of the label would look like this:</p> <pre>S:FINCL,OP,CHEM</pre> |
| Long form | The long form of the compartment name can have up to 80 characters. |
| Short form | The short form can contain up to 30 characters. |

Compartments are optional. A label can contain zero or more compartments. Oracle Label Security permits defining up to 10,000 compartments.

Not all labels need to have compartments. For example, you can specify `HIGHLY_SENSITIVE` and `CONFIDENTIAL` levels with no compartments, and a `SENSITIVE` level that does contain compartments.

When you analyze the sensitivity of data, you may find that some compartments are only useful at specific levels.

Figure 2-2 shows how compartments can be used to categorize data.

Figure 2-2 Label Matrix

Compartments

| | | | | |
|--------|-----------|-------|------|----|
| Levels | HS | FINCL | CHEM | OP |
| | S | FINCL | | OP |
| | P | | | OP |

Here, compartments `FINCL`, `CHEM`, and `OP` are used with the level `HIGHLY_SENSITIVE` (40). The label `HIGHLY_SENSITIVE.FINCL, CHEM` indicates a level of 40 with the two named compartments. Compartment `FINCL` is not more sensitive than `CHEM`, nor is `CHEM` more sensitive than `FINCL`. Note also that some data in the protected table may not belong to any compartment.

If compartments are specified, then a user whose level would normally permit access to a row's data will nevertheless be prevented from such access unless the user's label also contains all the compartments appearing in that row's label.

Group Components

Groups identify organizations owning or accessing the data, such as `EASTERN_REGION`, `WESTERN_REGION`, `WR_SALES`.

All data pertaining to a certain department can have that department's group in the label. Groups are useful for the controlled dissemination of data and for timely reaction to organizational change. When a company reorganizes, data access can change right along with the reorganization.

Groups are hierarchical. You can label data based upon your organizational infrastructure. A group can thus be associated with a parent group.

Figure 2-3 shows how you can define a set of groups corresponding to the following organizational hierarchy.

Figure 2-3 Group Example

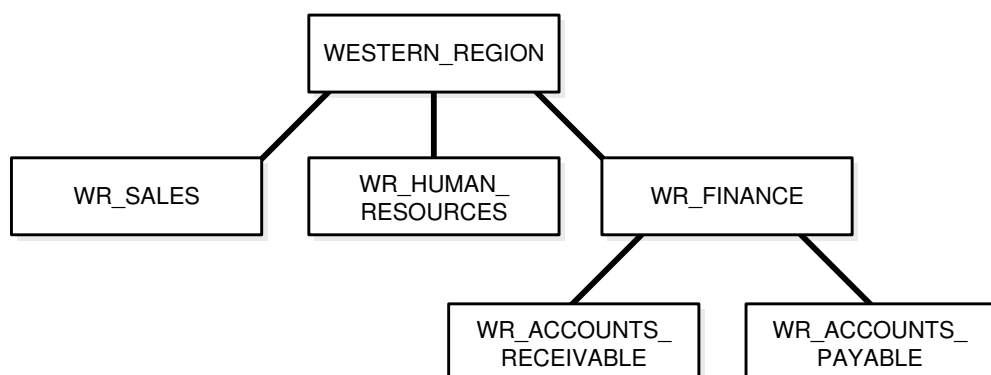

The `WESTERN_REGION` group includes three subgroups: `WR_SALES`, `WR_HUMAN_RESOURCES`, and `WR_FINANCE`. The `WR_FINANCE` subgroup is subdivided into `WR_ACCOUNTS_RECEIVABLE` and `WR_ACCOUNTS_PAYABLE`.

Table 2-7 shows how the organizational structure in this example can be expressed in the form of Oracle Label Security groups. Notice that the numeric form assigned to the groups affects display order only. The administrator specifies the hierarchy (that is, the parent/child relationships) separately.

Table 2-7 Group Example

| Numeric Form | Long Form | Short Form | Parent Group |
|--------------|-------------------------------------|---------------------|---------------------|
| 1000 | <code>WESTERN_REGION</code> | <code>WR</code> | |
| 1100 | <code>WR_SALES</code> | <code>WR_SAL</code> | <code>WR</code> |
| 1200 | <code>WR_HUMAN_RESOURCES</code> | <code>WR_HR</code> | <code>WR</code> |
| 1300 | <code>WR_FINANCE</code> | <code>WR_FIN</code> | <code>WR</code> |
| 1310 | <code>WR_ACCOUNTS_PAYABLE</code> | <code>WR_AP</code> | <code>WR_FIN</code> |
| 1320 | <code>WR_ACCOUNTS_RECEIVABLE</code> | <code>WR_AR</code> | <code>WR_FIN</code> |

Table 2-8 shows different ways of specifying groups.

Table 2-8 Forms of Specifying Groups

| Form | Explanation |
|--------------|--|
| Numeric form | <p>The numeric form of the group can range from 0 to 9999, and it must be unique for each policy.</p> <p>The numeric form does not indicate any kind of ranking. It does not indicate a parent-child relationship, or greater or less sensitivity. It only controls the display order of the short form group name in the label character string.</p> <p>For example, assume that a label is created that has the level <code>SENSITIVE</code>, the compartment <code>CHEMICAL</code>, and the groups <code>WESTERN_REGION</code> and <code>WR_HUMAN_RESOURCES</code> as listed in Table 2-7. When displayed in string format, the label looks like this:</p> <pre>S:CHEM:WR,WR_HR</pre> <p><code>WR</code> is displayed before <code>WR_HR</code> because 1000 comes before 1200.</p> |
| Long form | The long form of the group name can contain up to 80 characters. |
| Short form | The short form can contain up to 30 characters. |

Groups are optional; a label can contain zero or more groups. Oracle Label Security permits defining up to 10,000 groups.

All labels need not have groups. When you analyze the sensitivity of data, you may find that some groups are only used at specific levels. For example, you can specify `HIGHLY_SENSITIVE` and `CONFIDENTIAL` labels with no groups, and a `SENSITIVE` label that does contain groups.

Related Topics

- [Releasability Using Inverse Groups](#)
Oracle Label Security can implement the releasability using inverse groups.

Industry Examples of Levels, Compartments, and Groups

Oracle Label Security levels, compartments, groups are designed to be implemented in various industries.

[Table 2-9](#) illustrates the flexibility of Oracle Label Security levels, compartments, and groups, by listing typical ways in which they can be implemented in various industries.

Table 2-9 Typical Levels, Compartments, and Groups, by Industry

| Industry | Levels | Compartments | Groups |
|----------------------|----------------------|---------------------|----------------|
| Business to Business | TRADE_SECRET | MARKETING | AJAX_CORP |
| | PROPRIETARY | FINANCIAL | BILTWELL_CO |
| | COMPANY_CONFIDENTIAL | SALES | ACME_INC |
| | PUBLIC | PERSONNEL | ERSATZ_LTD |
| Financial Services | ACQUISITIONS | INSURANCE | CLIENT |
| | CORPORATE | EQUITIES | TRUSTEE |
| | CLIENT | TRUSTS | BENEFICIARY |
| | OPERATIONS | COMMERCIAL_LOANS | MANAGEMENT |
| Judicial | NATIONAL_SECURITY | CIVIL | ADMINISTRATION |
| | | CRIMINAL | DEFENSE |
| | PUBLIC | | PROSECUTION |
| Health Care | PRIMARY_PHYSICIAN | PHARMACEUTICAL | CDC |
| | PATIENT_CONFIDENTIAL | INFECTIOUS_DISEASES | RESEARCH |
| | PATIENT_RELEASE | | NURSING_STAFF |
| | | | HOSPITAL_STAFF |
| Defense | TOP_SECRET | ALPHA | UK |
| | SECRET | DELTA | NATO |
| | CONFIDENTIAL | SIGMA | SPAIN |
| | UNCLASSIFIED | | |

Label Syntax and Type

After label components are defined, you can create data labels by combining particular sets of level, compartments, and groups.

You can use the Oracle Enterprise Manager graphical user interface or a command line procedure. Character string representations of labels use the following syntax:

```
LEVEL:COMPARTMENT1,...,COMPARTMENTn:GROUP1,...,GROUPn
```

The text string specifying the label can have a maximum of 4,000 characters, including alphanumeric characters, spaces, and underscores. The labels are case-insensitive.

You can enter them in uppercase, lowercase, or mixed case, but the string is stored in the data dictionary and displayed in uppercase. A colon is used as the delimiter between components. It is not necessary to enter trailing delimiters in this syntax.

For example, you can create valid labels such as these:

```
SENSITIVE:FINANCIAL,CHEMICAL:EASTERN_REGION,WESTERN_REGION  
CONFIDENTIAL:FINANCIAL:VP_GRP  
SENSITIVE  
HIGHLY_SENSITIVE:FINANCIAL  
SENSITIVE::WESTERN_REGION
```

When a valid data label is created, two additional things occur:

- The label is automatically designated as a valid data label. This functionality limits the labels that can be assigned to data. Oracle Label Security can also create valid data labels dynamically at run time, from those that are predefined in Oracle Internet Directory. Most users, however, prefer to create the labels manually in order to limit data label proliferation.
- A numeric label tag is associated with the text string representing the label. It is this label tag, rather than the text string, that is stored in the policy label column of the protected table.

 **Note:**

For Oracle Label Security installations that do not use Oracle Internet Directory, dynamic creation of valid data labels uses the `TO_DATA_LABEL` function. Its usage should be tightly controlled.

Related Topics

- [Inserting Labels Using TO_DATA_LABEL](#)
The `TO_DATA_LABEL` function can generate new labels dynamically.
- [How Policy Label Column and Label Tags Work](#)
You should understand how policy label columns in a table or schema are created and filled.
- [Label Tags](#)
You can create label tags, either manually or automatically generating them, that define the label components.

How Data Labels and User Labels Work Together

A user can access data only within the range of his or her own label authorizations.

A user has the following:

- Maximum and minimum levels
- A set of authorized compartments
- A set of authorized groups (and, implicitly, authorization for any subgroups)

For example, if a user is assigned a maximum level of `SENSITIVE`, then the user potentially has access to `SENSITIVE`, `CONFIDENTIAL`, and `UNCLASSIFIED` data. The user has no access to `HIGHLY_SENSITIVE` data.

Figure 2-4 shows how data labels and user labels work together to provide access control in Oracle Label Security. While data labels are discrete, user labels are inclusive. Depending upon authorized compartments and groups, a user can potentially access data corresponding to all levels within his or her range.

Figure 2-4 Example: Data Labels and User Labels

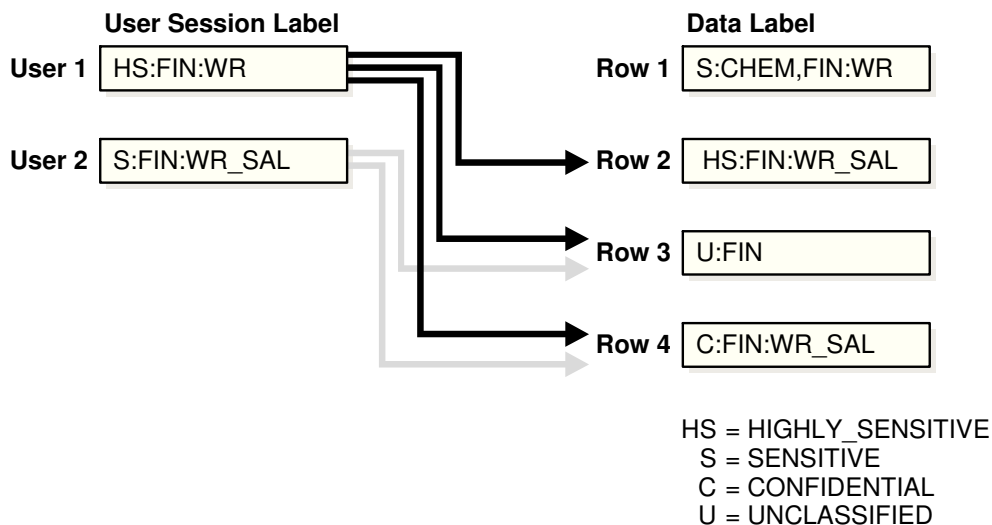

As shown in the figure, User 1 can access the rows 2, 3, and 4 because her maximum level is HS. She has access to the FIN compartment, and her access to group WR hierarchically includes group WR_SAL. She cannot access row 1 because she does not have the CHEM compartment. (A user must have authorization for *all* compartments in a row's data label to be able to access that row.)

User 2 can access rows 3 and 4. His maximum level is S, which is less than HS in row 2. Although he has access to the FIN compartment, he only has authorization for group WR_SAL. So, he cannot access row 1.

Figure 2-5 shows how data pertaining to an organizational hierarchy fits into data levels and compartments.

Figure 2-5 How Label Components Interrelate

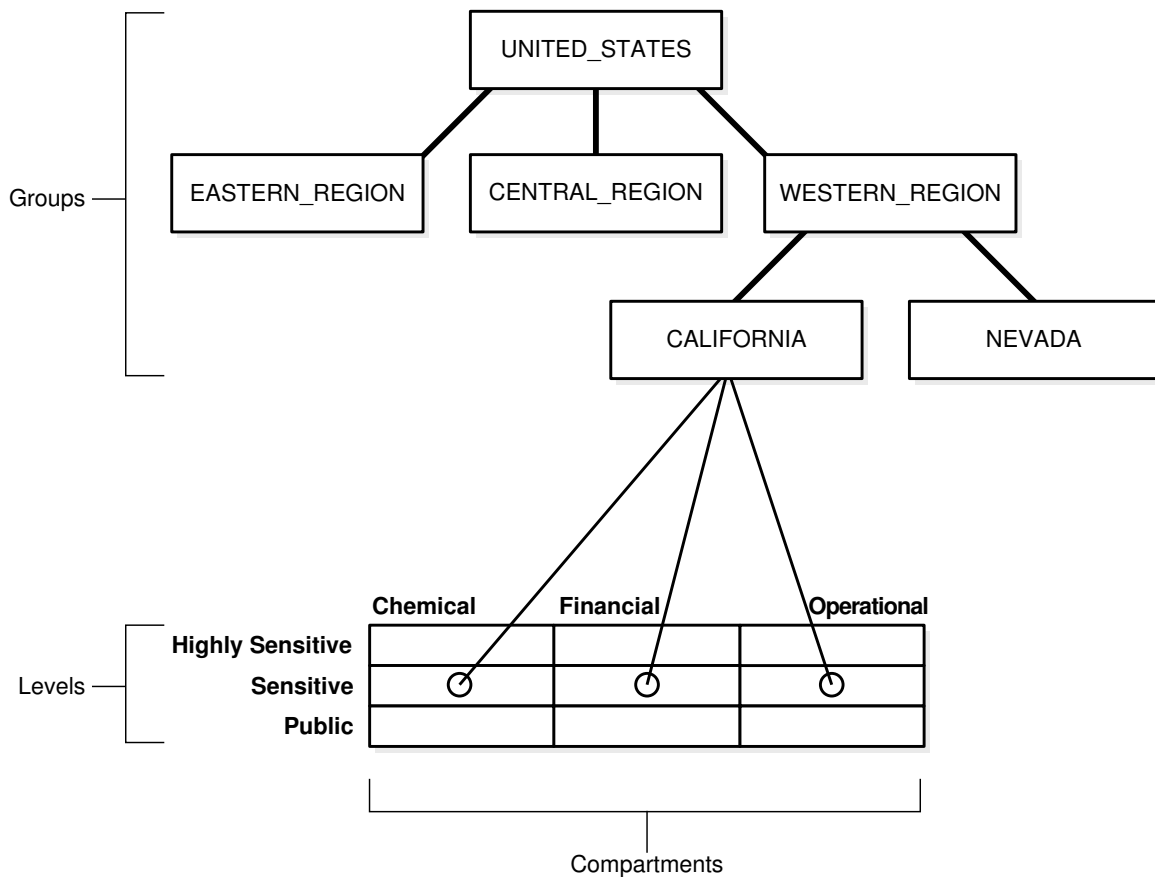

For example, the `UNITED_STATES` group includes three subgroups: `EASTERN_REGION`, `CENTRAL_REGION`, and `WESTERN_REGION`. The `WESTERN_REGION` subgroup is further subdivided into `CALIFORNIA` and `NEVADA`. For each group and subgroup, there may be data belonging to some of the valid compartments and levels within the database. So, there may be `SENSITIVE` data that is `FINANCIAL`, within the `CALIFORNIA` subgroup.

Note that data is generally labeled with a single group whereas users' labels form a hierarchy. If users have a particular group, then that group may implicitly include child groups. This way a user associated with the `UNITED_STATES` group has access to all data, but a user associated with `CALIFORNIA` would have access to data pertaining to only that subgroup.

Administration of Labels

Oracle Label Security provides administrative interfaces to define and manage the labels used in a database.

You define labels in Oracle Database using Oracle Label Security packages or by using Oracle Enterprise Manager. Initially, an administrator must define the levels, compartments, and groups that compose the labels, and then, the user can define the set of valid data labels for the contents of the database.

An administrator can apply a policy to individual tables in the database or to entire application schemas. Finally, the administrator assigns to each database user the label components (and privileges, if needed) required for the user's job function.

3

Access Controls and Privileges

Oracle provides access controls and privileges that determine the *type* of access users can have to labeled rows.

- [Access Mediation](#)
To access data protected by an Oracle Label Security policy, a user must have authorizations based on the labels defined for the policy.
- [How the Session Label and Row Label Work](#)
It is important to understand session labels and row labels.
- [How User Authorizations Work](#)
Oracle Label Security provides authorizations set by the Oracle Label Security administrator and authorizations set by computed session labels.
- [Evaluation of Labels for Access Mediation](#)
Oracle Label Security evaluates labels by comparing the user's label components to the row's label components.
- [Oracle Label Security Privileges](#)
Oracle Label Security provides a set of database and row label privileges.
- [Working with Multiple Oracle Label Security Policies](#)
You can use multiple Oracle Label Security policies in both a single database environments and in a distributed environments.

Related Topics

- [Understanding Data Labels and User Labels](#)
You should understand fundamental concepts of data labels and user labels.

Access Mediation

To access data protected by an Oracle Label Security policy, a user must have authorizations based on the labels defined for the policy.

[Figure 3-1](#) illustrates the relationships between users, data, and labels.

- Data labels specify the sensitivity of data rows.
- User labels provide the appropriate authorizations to users.
- Access mediation between users and rows of data depends on users' labels.

Figure 3-1 Relationships Between Users, Data, and Labels

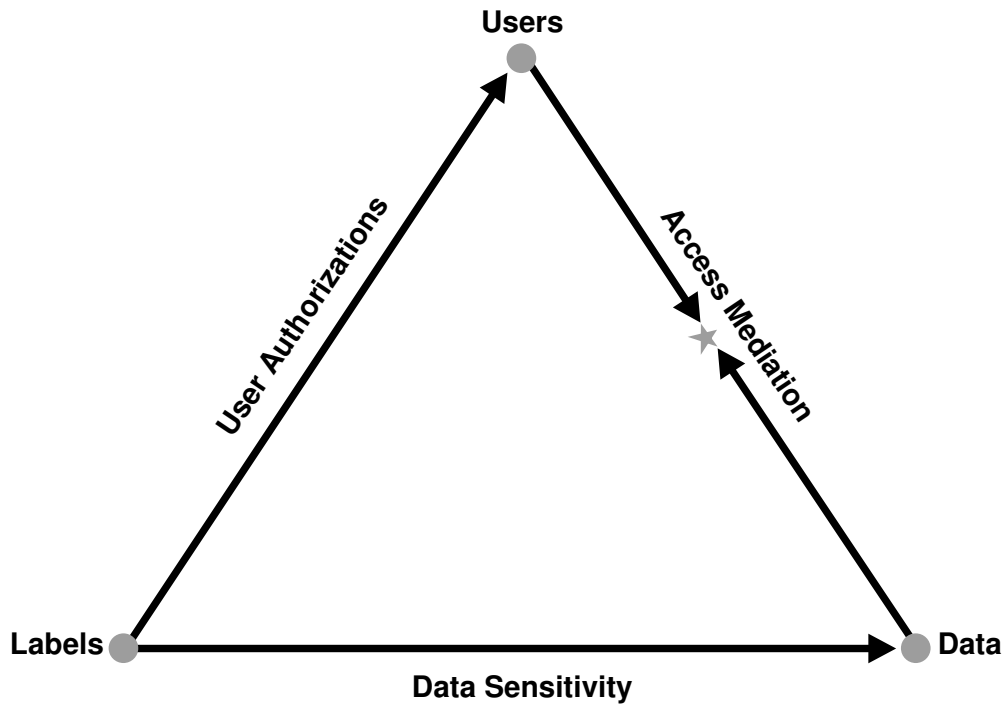

Note:

Oracle Label Security enforcement options affect how access controls apply to tables and schemas. This chapter assumes that all policy enforcement options are in effect.

Related Topics

- [Oracle Label Security Policy Enforcement Options](#)
Oracle Label Security provides a set of policy enforcement options.

How the Session Label and Row Label Work

It is important to understand session labels and row labels.

- [The Session Label](#)
Each Oracle Label Security user has authorizations that include special components.
- [The Row Label](#)
When a user writes data without specifying its label, a *row label* is assigned automatically, using the user's session label.
- [Session Label Example](#)
The session label and the row label can fall anywhere within the range of the user's level, compartment, and group authorizations.

The Session Label

Each Oracle Label Security user has authorizations that include special components.

- A maximum and minimum level
- A set of authorized compartments
- A set of authorized groups
- For each compartment and group, a specification of read-only access, or read/write access

The administrator also specifies the user's initial session label when setting up these authorizations for the user.

The *session label* is the particular combination of level, compartments, and groups at which a user works at any given time. The user can change the session label to any combination of components for which the user is authorized.

Related Topics

- [SA_SESSION Session Management PL/SQL Package](#)
The `SA_SESSION` PL/SQL package manages session behavior for user authorizations.

The Row Label

When a user writes data without specifying its label, a *row label* is assigned automatically, using the user's session label.

However, the user can set the label for the written row, within certain restrictions on the components of the label he specifies. The level of this label can be set to any level within the range specified by the administrator. For example, it can be set to the level of the user's current session label down to the user's minimum level. However, the compartments and groups for this row's new label are more restricted. The new label can include only those compartments and groups contained in the current session label and, among those, only the ones for which the user has write access.

When the administrator sets up the user authorizations, he or she also specifies an initial default row label.

See Also:

- [SA_USER_ADMIN PL/SQL Package](#)
- [SA_SESSION Session Management PL/SQL Package](#)

Session Label Example

The session label and the row label can fall anywhere within the range of the user's level, compartment, and group authorizations.

In [Figure 3-2](#), the user's maximum level is `SENSITIVE` and the minimum level is `UNCLASSIFIED`. However, his default session label is `C:FIN,OP:WR`. In this example, the

administrator has set the user's session label so that the user connects to the database at the `CONFIDENTIAL` level.

Similarly, although the user is authorized for compartments `FIN` and `OP`, and group `WR`, the administrator could set the session label so that the user connects with only compartment `FIN` and group `WR`.

Figure 3-2 User Session Label

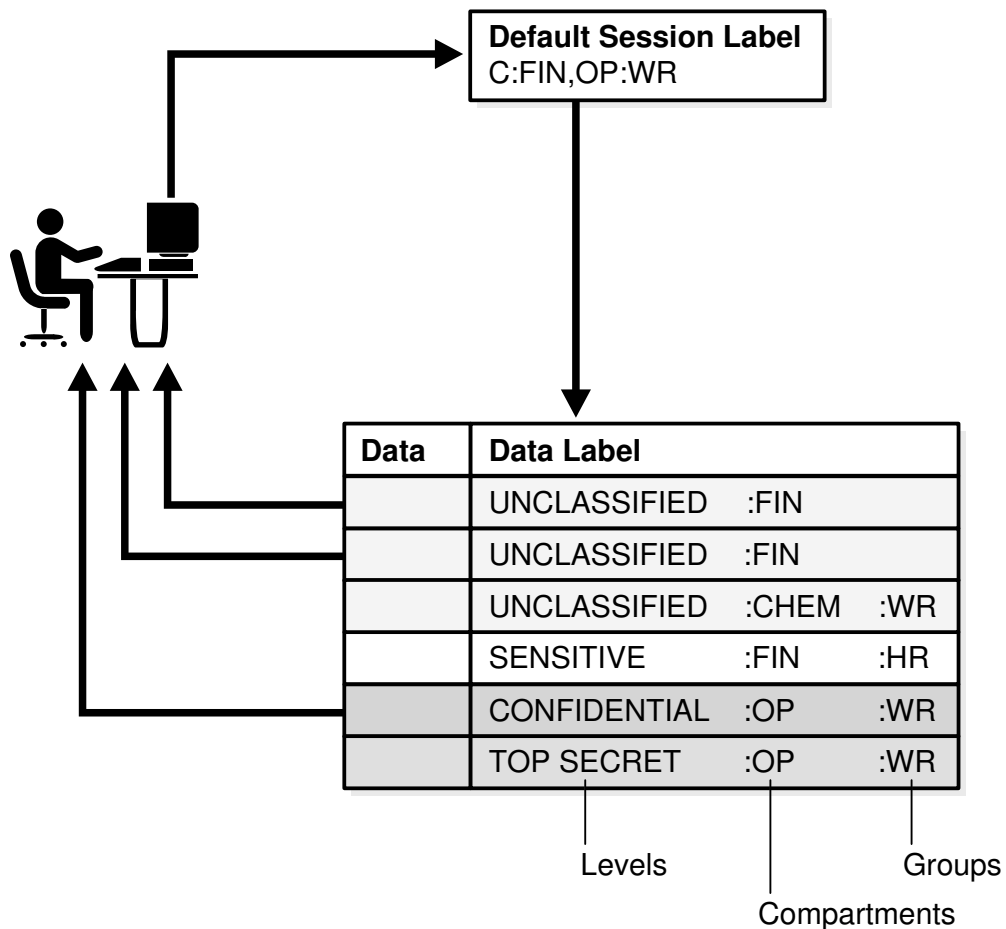

Related Topics

- [SA_USER_ADMIN.SET_COMPARTMENTS](#)
The `SA_USER_ADMIN.SET_COMPARTMENTS` procedure assigns compartments to a user and identifies default values for the user's session label and row label.
- [SA_USER_ADMIN.ALTER_COMPARTMENTS](#)
The `SA_USER_ADMIN.ALTER_COMPARTMENTS` procedure changes the write access, default label indicator, and row label indicator for the specified compartments.

How User Authorizations Work

Oracle Label Security provides authorizations set by the Oracle Label Security administrator and authorizations set by computed session labels.

- [Authorizations Set by the Administrator](#)
The administrator explicitly sets authorizations for levels, compartments, and groups.
- [Computed Session Labels](#)
Oracle Label Security automatically computes a number of labels based on the value of the session label.

Authorizations Set by the Administrator

The administrator explicitly sets authorizations for levels, compartments, and groups.

- [Authorized Levels](#)
The administrator explicitly sets the level authorization for an Oracle Label Security policy.
- [Authorized Compartments](#)
The administrator specifies the list of compartments that a user can place in their session label.
- [Authorized Groups](#)
You must specify a list of groups that a user can place in a session label and grant write access for each group.

Authorized Levels

The administrator explicitly sets the level authorization for an Oracle Label Security policy.

Table 3-1 Authorized Levels Set by the Administrator

| Authorization | Meaning |
|------------------------|--|
| User Max Level | The maximum ranking of sensitivity that a user can access during read and write operations |
| User Min Level | The minimum ranking of sensitivity that a user can access during write operations. The User Max Level must be equal to or greater than the User Min Level. |
| User Default Level | The level that is assumed by default when connecting to Oracle Database |
| User Default Row Level | The level that is used by default when inserting data into Oracle Database |

For example, in Oracle Enterprise Manager, the administrator might set the following level authorizations for user Joe:

| Type | Short Name | Long Name | Description |
|---------|------------|------------------|----------------------|
| Maximum | HS | HIGHLY_SENSITIVE | User's highest level |
| Minimum | P | PUBLIC | User's lowest level |
| Default | C | CONFIDENTIAL | User's default level |
| Row | C | CONFIDENTIAL | Row level on INSERT |

Authorized Compartments

The administrator specifies the list of compartments that a user can place in their session label.

Write access must be explicitly given for each compartment. A user cannot directly insert, update, or delete a row that contains a compartment that she does not have authorization to write.

For example, in Oracle Enterprise Manager, the administrator might set the following compartment authorizations for user Joe:

| Short Name | Long Name | WRITE | DEFAULT | ROW |
|------------|-------------|-------|---------|-----|
| CHEM | CHEMICAL | YES | YES | NO |
| FINCL | FINANCIAL | YES | YES | NO |
| OP | OPERATIONAL | YES | YES | YES |

Figure 3-3 Setting Up Authorized Compartments In Enterprise Manager

Compartments

Specify zero or more compartments to be assigned to the user.

| Select | Short Name | Write | Default | Row |
|-------------------------------------|------------|-------------------------------------|-------------------------------------|-------------------------------------|
| <input checked="" type="checkbox"/> | CHEM | <input checked="" type="checkbox"/> | <input checked="" type="checkbox"/> | <input type="checkbox"/> |
| <input checked="" type="checkbox"/> | FINCL | <input checked="" type="checkbox"/> | <input checked="" type="checkbox"/> | <input type="checkbox"/> |
| <input checked="" type="checkbox"/> | OP | <input checked="" type="checkbox"/> | <input checked="" type="checkbox"/> | <input checked="" type="checkbox"/> |

In [Figure 3-3](#), the row designation indicates whether the compartment should be used as part of the default row label for newly inserted data. Note also that the policy option must be in effect for this setting to be valid.

Authorized Groups

You must specify a list of groups that a user can place in a session label and grant write access for each group.

For example, in Oracle Enterprise Manager, the administrator might set the following group authorizations:

| Short Name | Long Name | WRITE | DEFAULT | ROW | Parent |
|------------|------------------------|-------|---------|-----|--------|
| WR_HR | WR_HUMAN_RESOURCES | YES | YES | YES | WR |
| WR_AP | WR_ACCOUNTS_PAYABLE | YES | YES | NO | WR_FIN |
| WR_AR | WR_ACCOUNTS_RECEIVABLE | YES | YES | NO | WR_FIN |

Figure 3-4 Setting Up Authorized Groups in Enterprise Manager

Groups

Specify zero or more groups to be assigned to the user.

[Select All](#) | [Select None](#)

| Select | Short Name | Write | Default | Row |
|-------------------------------------|------------|-------------------------------------|-------------------------------------|-------------------------------------|
| <input checked="" type="checkbox"/> | WR_HR | <input checked="" type="checkbox"/> | <input checked="" type="checkbox"/> | <input checked="" type="checkbox"/> |
| <input checked="" type="checkbox"/> | WR_AP | <input checked="" type="checkbox"/> | <input checked="" type="checkbox"/> | <input type="checkbox"/> |
| <input checked="" type="checkbox"/> | WR_AR | <input checked="" type="checkbox"/> | <input checked="" type="checkbox"/> | <input type="checkbox"/> |

In this figure, the row designation indicates whether the group should be used as part of the default row label for newly inserted data. Note also that the LABEL_DEFAULT policy option must be in effect for this setting to be valid.

Related Topics

- [LABEL_DEFAULT: Using the Session's Default Row Label](#)
A user can update a row without specifying a label value, because the updated row uses its original label.

Computed Session Labels

Oracle Label Security automatically computes a number of labels based on the value of the session label.

These include:

Table 3-2 Computed Session Labels

| Computed Label | Definition |
|---------------------|--|
| Maximum Read Label | The user's maximum level combined with any combination of compartments and groups for which the user is authorized. |
| Maximum Write Label | The user's maximum level combined with the compartments and groups for which the user has been granted write access. |
| Minimum Write Label | The user's minimum level. |
| Default Read Label | The single default level combined with compartments and groups that have been designated as default for the user. |
| Default Write Label | A subset of the default read label, containing the compartments and groups to which the user has been granted write access. The level component is equal to the level default in the read label. This label is automatically derived from the read label based on the user's write authorizations. |
| Default Row Label | The combination of components between the user's minimum write label and the maximum write label, which has been designated as the default value for the data label for inserted data. |

Related Topics

- [Computed Labels with Inverse Groups](#)
Inverse groups affect computed label values.

Evaluation of Labels for Access Mediation

Oracle Label Security evaluates labels by comparing the user's label components to the row's label components.

This way, the Oracle Label Security policy can determine whether the user can access the data. This enables Oracle Label Security to evaluate whether the user is authorized to perform the requested operation on the data in the row.

- [About Read and Write Access](#)
Although data labels are stored in a column within data records, information about user authorizations is stored in relational tables.
- [How Oracle Label Security Algorithm for Read Access Works](#)
The `READ_CONTROL` enforcement determines the ability to read data in a row.
- [How the Oracle Label Security Algorithm for Write Access Works](#)
In the context of Oracle Label Security, `WRITE_CONTROL` enforcement determines the ability to insert, update, or delete data in a row.

About Read and Write Access

Although data labels are stored in a column within data records, information about user authorizations is stored in relational tables.

When a user logs on, the tables are used to dynamically generate user labels for use during the session.

- [Difference Between Read and Write Operations](#)
Two fundamental types of access mediation on Data Manipulation language (DML) operations exist within protected tables: read access and write access.
- [Propagation of Read/Write Authorizations on Groups](#)
When groups are organized hierarchically, a user's assigned groups include all subgroups that are subordinate to the group to which the user belongs.

Difference Between Read and Write Operations

Two fundamental types of access mediation on Data Manipulation language (DML) operations exist within protected tables: read access and write access.

The user has a maximum authorization for the data he or she can read; the user's write authorization is a subset of that. The minimum write level controls the user's ability to disseminate data by lowering its sensitivity. The user cannot write data with a level lower than the minimum level the administrator assigned to this user.

In addition, there are separate lists of compartments and groups for which the user is authorized; that is, for which the user has at least read access. An access flag indicates whether the user can also write to individual compartments or groups.

Propagation of Read/Write Authorizations on Groups

When groups are organized hierarchically, a user's assigned groups include all subgroups that are subordinate to the group to which the user belongs.

In this case, the user's read/write authorizations on a parent group flow down to all the subgroups.

Consider the parent group `WESTERN_REGION`, with three subgroups as illustrated in [Figure 3-5](#). If the user has read access to `WESTERN_REGION`, then the read access is also granted to the three subgroups. The administrator can give the user write access to subgroup `WR_FINANCE`, without granting write access to the `WESTERN_REGION` parent group (or to the other subgroups). On the other hand, if the user has read/write access on `WESTERN_REGION`, then read/write access is also granted on all of the subgroups subordinate to it in the tree.

Write authorization on a group does not give a user write authorization on the parent group. If a user has read-only access to `WESTERN_REGION` and `WR_FINANCE`, then the administrator can grant write access to `WR_ACCOUNTS_RECEIVABLE`, without affecting the read-only access to the higher-level groups.

Figure 3-5 Subgroup Inheritance of Read/Write Access

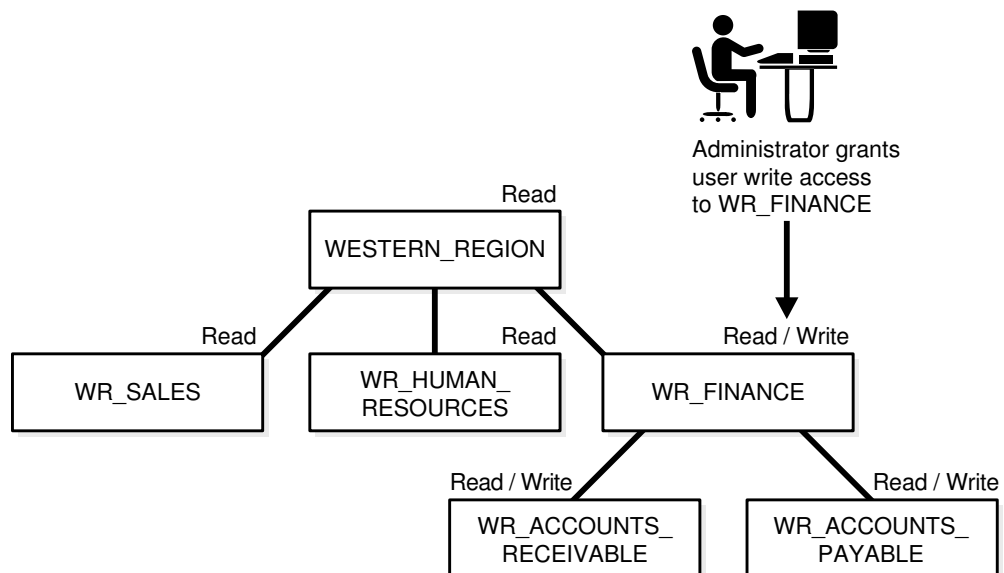

Related Topics

- [How Inverse Groups Work](#)
Inverse groups are implemented in a special way and are organized to suit the needs of Oracle Label Security.

How Oracle Label Security Algorithm for Read Access Works

The `READ_CONTROL` enforcement determines the ability to read data in a row.

The following rules are used, in the sequence listed, to determine a user's read access to a row of data:

1. The user's level must be *greater than or equal to* the level of the data.
2. The user's label must include *at least one of the groups* that belong to the data (or the parent group of one such subgroup).
3. The user's label must include *all the compartments* that belong to the data.

If the user's label passes these tests, then it is said to dominate the row's label.

Note that there is no notion of read or write access connected with levels. This is because the administrator specifies a range of levels (minimum to maximum) within which a user can potentially read and write. At any time, the user can read all data equal to or less than the current session level. No privileges (other than `FULL`) allow the user to write below the minimum authorized level.

Figure 3-6 illustrates how the label evaluation process proceeds from levels to groups to compartments. Note that if the data label is null or invalid, then the user is denied access.

Figure 3-6 Label Evaluation Process for Read Access

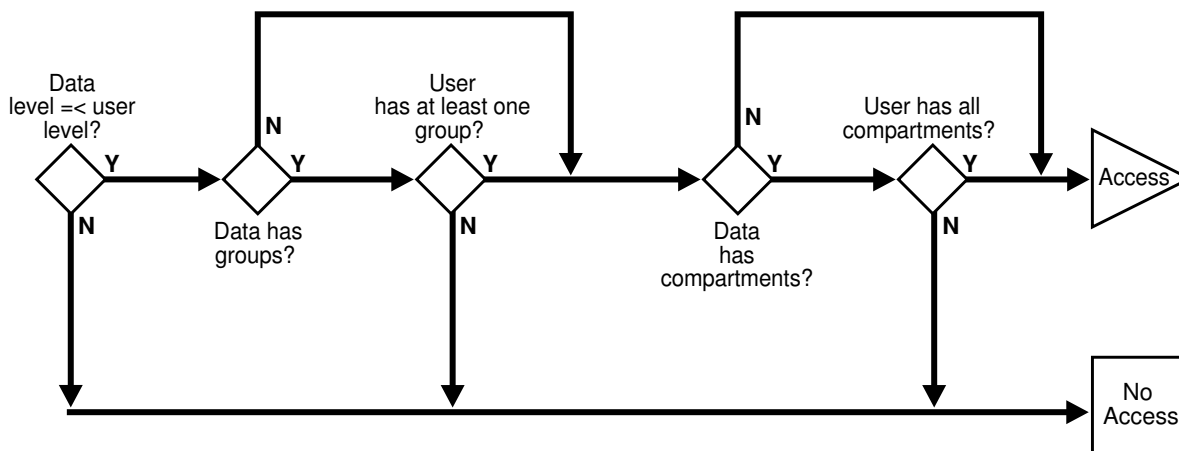

As a read access request comes in, Oracle Label Security evaluates each row to determine the following:

1. Is the user's level equal to, or greater than, the level of the data?
2. If so, does the user have access to at least one of the groups present in the data label?
3. If so, does the user have access to all the compartments present in the data label? (That is, are the data's compartments a subset of the user's compartments?)

If the answer is no at any stage in this evaluation process, then Oracle Label Security denies access to the row and moves on to evaluate the next row of data.

Oracle Label Security policies allow user sessions to read rows at their label and below, which is called *reading down*. Sessions cannot read rows at labels that they do not dominate.

For example, if you are logged in at `SENSITIVE:ALPHA,BETA`, you can read a row labeled `SENSITIVE:ALPHA` because your label dominates that of the row. However, you cannot read a row labeled `SENSITIVE:ALPHA,GAMMA` because your label does not dominate that of the row.

Note that the user can gain access to the rows otherwise denied, if she or he has special Oracle Label Security privileges.

Related Topics

- [Privileges Defined by Oracle Label Security Policies](#)
Oracle Label Security supports special privileges that allow authorized users to bypass certain parts of the policy.
- [How the Access Control Enforcement Options Work](#)
Access control options limit the rows accessible for `SELECT`, `UPDATE`, `INSERT`, or `DELETE` operations to only those rows whose labels meet established policies.

How the Oracle Label Security Algorithm for Write Access Works

In the context of Oracle Label Security, `WRITE_CONTROL` enforcement determines the ability to insert, update, or delete data in a row.

`WRITE_CONTROL` enables you to control data access with ever finer granularity. Granularity increases when compartments are added to levels. It increases again when groups are added to compartments. Access control becomes even more fine grained when you can manage the user's ability to write the data that he can read.

To determine whether a user can write a particular row of data, Oracle Label Security evaluates the following rules, in the order given:

1. The level in the data label must be greater than or equal to the user's minimum level and less than or equal to the user's session level.
2. When groups are present, the user's label must include *at least one of the groups with write access* that appear in the data label (or the parent of one such subgroup). In addition, the user's label must include *all the compartments* in the data label.
3. When no groups are present, the user's label must have write access on *all of the compartments* in the data label.

To state tests 2 and 3 another way:

- If the label has *no* groups, then the user must have write access on all the compartments in the label in order to write the data.
- If the label *does* have groups and the user has write access to one of the groups, she only needs read access to the compartments in order to write the data.

Just as with read operations, the label evaluation process proceeds from levels to groups to compartments. Note that the user cannot write any data below the authorized minimum level, nor above the current session level. The user can always read below the minimum level.

[Figure 3-7](#) illustrates how the process works with `INSERT`, `UPDATE`, and `DELETE` operations. Note that if the data label is null or invalid, then the user is denied access.

Figure 3-7 Label Evaluation Process for Write Access

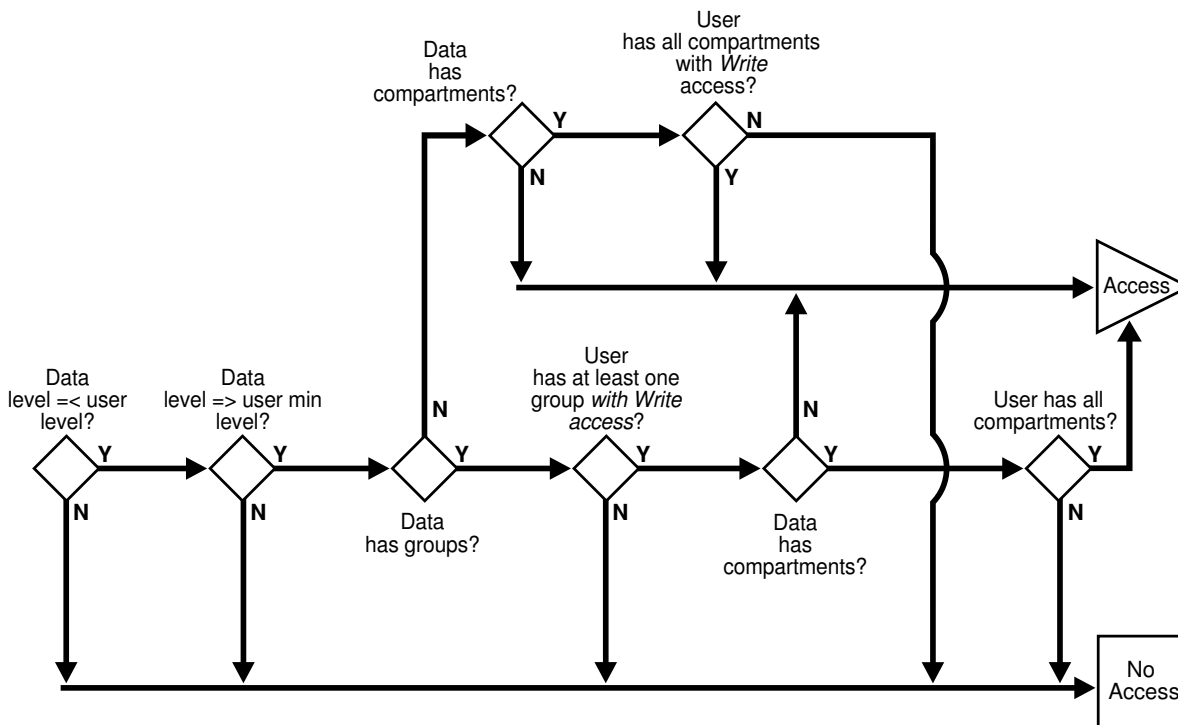

As an access request comes in, Oracle Label Security evaluates each row to determine the following:

1. Is the data's level equal to, or less than the level of the user?
2. Is the data's level equal to, or greater than the user's minimum level?
3. If the data's level falls within the foregoing bounds, then does the user have write access to at least one of the groups present in the data label?
4. If so, does the user have access to all the compartments with at least read access that are present in the data label?
5. If there are no groups but there are compartments, then does the user have write access to all of the compartments?

If the answer is no at any stage in this evaluation process, then Oracle Label Security denies access to the row, and moves on to evaluate the next row of data.

Consider a situation in which your session label is `S:ALPHA,BETA` but you have write access to only compartment `ALPHA`. In this case, you can read a row with the label `S:ALPHA,BETA` but you cannot update it.

In summary, write access is enforced on `INSERT`, `UPDATE` and `DELETE` operations upon the data in the row.

In addition, each user may have an associated minimum level below which the user cannot write. The user cannot update or delete any rows labeled with levels below the minimum, and cannot insert a row with a row label containing a level less than the minimum.

Related Topics

- [How the Access Control Enforcement Options Work](#)
Access control options limit the rows accessible for `SELECT`, `UPDATE`, `INSERT`, or `DELETE` operations to only those rows whose labels meet established policies.

Oracle Label Security Privileges

Oracle Label Security provides a set of database and row label privileges.

- [Privileges Defined by Oracle Label Security Policies](#)
Oracle Label Security supports special privileges that allow authorized users to bypass certain parts of the policy.
- [Special Access Privileges](#)
A user's authorizations can be modified with any of four privileges.
- [Special Row Label Privileges](#)
Once the label on a row has been set, Oracle Label Security privileges are required to modify the label.
- [System Privileges, Object Privileges, and Policy Privileges](#)
Oracle Label Security privileges are different from the standard Oracle Database system and object privileges.
- [Access Mediation and Views](#)
Prior to accessing data through a view, the users must have the appropriate system and object privileges on the view.
- [Access Mediation and Program Unit Execution](#)
The privileges with which procedures that are owned by different users are executed differently in Oracle Database and Oracle Label Security.
- [Access Mediation and Policy Enforcement Options](#)
An administrator can choose from among a set of policy enforcement options when applying an Oracle Label Security policy to individual tables.

Privileges Defined by Oracle Label Security Policies

Oracle Label Security supports special privileges that allow authorized users to bypass certain parts of the policy.

[Table 3-3](#) summarizes the full set of privileges that can be granted to users or trusted stored program units. Each privilege is more fully discussed after the table.

Table 3-3 Oracle Label Security Privileges

| Security Privilege | Explanation |
|--------------------|---|
| READ | Allows read access to all data protected by the policy |
| FULL | Allows full read and write access to all data protected by the policy |
| COMPACCESS | Allows a session access to data authorized by the row's compartments, independent of the row's groups |
| PROFILE_ACCESS | Allows a session to change its labels and privileges to those of a different user |

Table 3-3 (Cont.) Oracle Label Security Privileges

| Security Privilege | Explanation |
|--------------------|---|
| WRITEUP | Allows users to set or raise only the level, within a row label, up to the maximum level authorized for the user. (Active only if LABEL_UPDATE is active.) |
| WRITEDOWN | Allows users to set or lower the level, within a row label, to any level equal to or greater than the minimum level authorized for the user. (Active only if LABEL_UPDATE is active.) |
| WRITEACROSS | Allows a user to set or change groups and compartments of a row label, but does not allow changes to the level. (Active only if LABEL_UPDATE is active.) |

Special Access Privileges

A user's authorizations can be modified with any of four privileges.

- **READ Privilege**
A user with the `READ` privilege can read all data protected by the policy, regardless of the authorizations or session label.
- **FULL Privilege**
The `FULL` privilege has the same effect and benefits as the `READ` privilege, with one difference.
- **COMPACCESS Privilege**
The `COMPACCESS` privilege allows a user to access data based on the row label's compartments, independent of the row label's groups.
- **PROFILE_ACCESS Privilege**
The `PROFILE_ACCESS` privilege allows a session to change its session labels and session privileges to those of a different user.

READ Privilege

A user with the `READ` privilege can read all data protected by the policy, regardless of the authorizations or session label.

The user does not even need to have label authorizations.

Note, in addition, that a user with `READ` privilege can *write* to any data rows for which he or she has write access, based on any label authorizations.



Note:

Access mediation is still enforced on `UPDATE`, `INSERT`, and `DELETE` operations.

This privilege is useful for system administrators who need to export data but who should not be allowed to change data. It is also useful for people who must run reports and compile information but not change data. The `READ` privilege enables optimal

performance on `SELECT` statements, because the system behaves as though the Oracle Label Security policy were not even present.

FULL Privilege

The `FULL` privilege has the same effect and benefits as the `READ` privilege, with one difference.

A user with the `FULL` privilege can also *write* to all the data.

For a user with the `FULL` privilege, the `READ` and `WRITE` algorithms are not enforced.

Note that Oracle system and object authorizations are still enforced. For example, a user must still have `SELECT` on the application table. The `FULL` authorization turns off the access mediation check at the individual row level.

COMPACCESS Privilege

The `COMPACCESS` privilege allows a user to access data based on the row label's compartments, independent of the row label's groups.

If a row label has no compartments, then access is determined by the group authorizations. However, when compartments do exist and access to them is authorized, then the group authorization is bypassed. This allows a privileged user whose label matches all the compartments of the data to access any data in any particular compartment, independent of what groups may own or otherwise be allowed access to the data.

Figure 3-8 shows the label evaluation process for read access with the `COMPACCESS` privilege. Note that if the data label is null or invalid, then the user is denied access.

Figure 3-8 Label Evaluation Process for Read Access with `COMPACCESS` Privilege

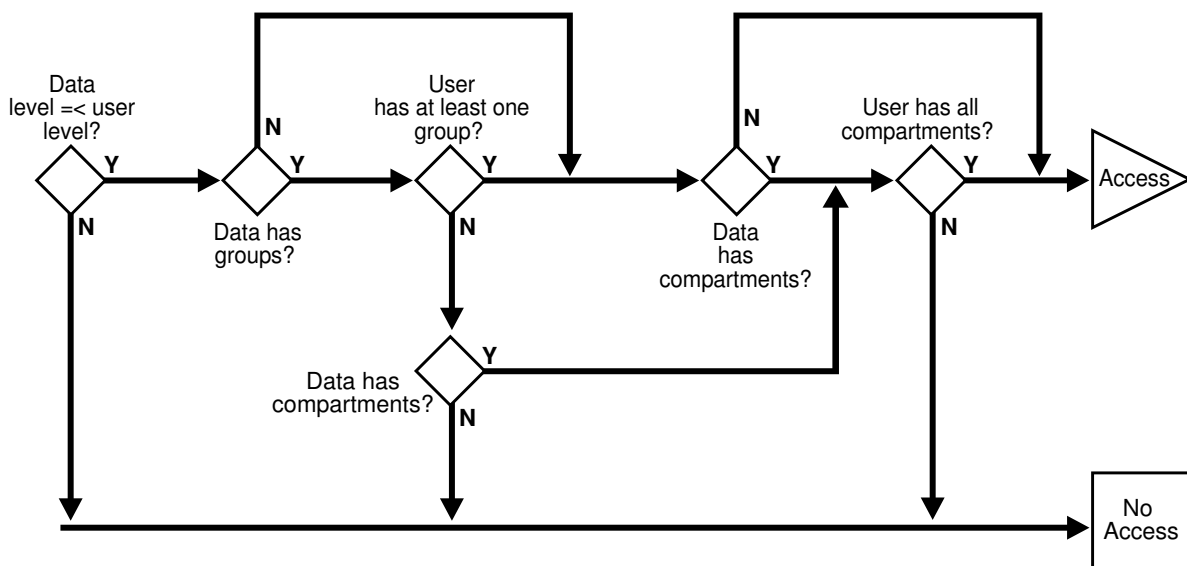
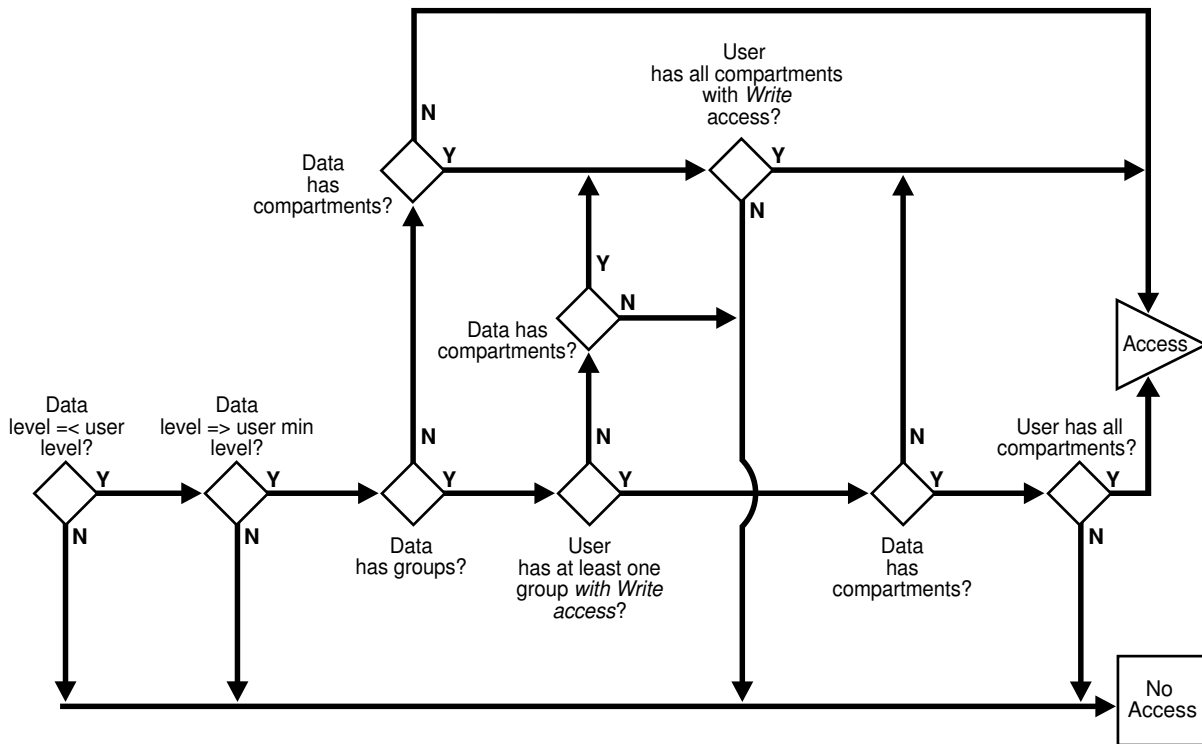

Figure 3-9 shows the label evaluation process for write access with `COMPACCESS` privilege. Note that if the data label is null or invalid, then the user is denied access.

Figure 3-9 Label Evaluation Process for Write Access with COMPACCESS Privilege



PROFILE_ACCESS Privilege

The `PROFILE_ACCESS` privilege allows a session to change its session labels and session privileges to those of a different user.

This is a very powerful privilege, because the user can potentially become a user with `FULL` privileges. This privilege cannot be granted to a trusted stored program unit.

Special Row Label Privileges

Once the label on a row has been set, Oracle Label Security privileges are required to modify the label.

Note that the `LABEL_UPDATE` enforcement option must be on for these label modification privileges to be enforced. When a user updates a row label, the new label and old label are compared, and the required privileges are determined.

The special row label privileges include:

- **WRITEUP Privilege**
The `WRITEUP` privilege enables the user to raise the level of data within a row, without compromising the compartments or groups.
- **WRITEDOWN Privilege**
The `WRITEDOWN` privilege enables the user to lower the level of data within a row, without compromising the compartments or groups.

- **WRITEACROSS Privilege**
The `WRITEACROSS` privilege allows the user to change the compartments and groups of data, without altering its sensitivity level.

WRITEUP Privilege

The `WRITEUP` privilege enables the user to raise the level of data within a row, without compromising the compartments or groups.

This privilege enables a user to raise the level up to his or her maximum authorized level. You can find the privileges that users have by querying the `ALL_SA_USER_PRIVS` data dictionary view.

For example, an authorized user can raise the level of a data row that has a level lower than his own minimum level. If a row is `UNCLASSIFIED` and the user's maximum level is `SENSITIVE`, then the row's level can be raised to `SENSITIVE`. It can be raised above the current session level, but it cannot change the compartments.

WRITEDOWN Privilege

The `WRITEDOWN` privilege enables the user to lower the level of data within a row, without compromising the compartments or groups.

The user can lower the level to any level equal to or greater than his or her minimum authorized level. You can find the privileges that have been granted to a user by querying the `ALL_SA_USER_PRIVS` data dictionary view.

WRITEACROSS Privilege

The `WRITEACROSS` privilege allows the user to change the compartments and groups of data, without altering its sensitivity level.

This guarantees, for example, that `SENSITIVE` data remains at the `SENSITIVE` level, but at the same time enables the data's dissemination to be managed.

It lets the user change compartments and groups to anything that is currently defined as a valid compartment or group within the policy, while maintaining the level. With the `WRITEACROSS` privilege, a user with read access to one group (or more) can write to a different group without explicitly being given access to it.

You can find the privileges that have been granted to a user by querying the `ALL_SA_USER_PRIVS` data dictionary view.

System Privileges, Object Privileges, and Policy Privileges

Oracle Label Security privileges are different from the standard Oracle Database system and object privileges.

Table 3-4 Types of Privilege

| Source | Privileges | Definition |
|-----------------|-------------------|---|
| Oracle Database | System Privileges | The right to run a particular type of SQL statement |
| Oracle Database | Object Privileges | The right to access another user's object |

Table 3-4 (Cont.) Types of Privilege

| Source | Privileges | Definition |
|-----------------------|-------------------|--|
| Oracle Label Security | Policy Privileges | The ability to bypass certain parts of the label security policy |

Oracle Database enforces the discretionary access control privileges that a user has been granted. By default, a user has no privileges except those granted to the `PUBLIC` user group. A user must explicitly be granted the appropriate privilege to perform an operation.

For example, to read an object in Oracle Database, you must either be the object's owner, or be granted the `SELECT` privilege on the object, or be granted the `SELECT ANY TABLE` system privilege. Similarly, to update an object, you must either be the object's owner, or be granted the `UPDATE` privilege on the object, or be granted the `UPDATE ANY TABLE` privilege.

See Also:

Oracle Database Security Guide for more information about managing system privileges and object privileges

Access Mediation and Views

Prior to accessing data through a view, the users must have the appropriate system and object privileges on the view.

If the underlying table (on which the view is based) is protected by Oracle Label Security, then the user of the view must have authorization from Oracle Label Security to access specific rows of labeled data.

Access Mediation and Program Unit Execution

The privileges with which procedures that are owned by different users are executed differently in Oracle Database and Oracle Label Security.

For example, In Oracle Database, if `user1` executes a procedure that belongs to `user2`, then the procedure runs with `user2`'S system and object privileges. You can find the privileges that have been granted to a user by querying the `DBA_SYS_PRIVS` data dictionary view. However, any procedure executed by `user1` runs with `user1`'s own Oracle Label Security labels and privileges. This is true even when `user1` executes stored program units owned by other users.

Figure 3-10 illustrates this process:

- Stored program units run with the DAC privileges of the procedure's owner (`user2`).
- In addition, stored program units accessing tables protected by Oracle Label Security mediate access to data rows based on the label attached to the row, and the Oracle Label Security labels and privileges of the invoker of the procedure (`user1`).

Figure 3-10 Stored Program Unit Execution

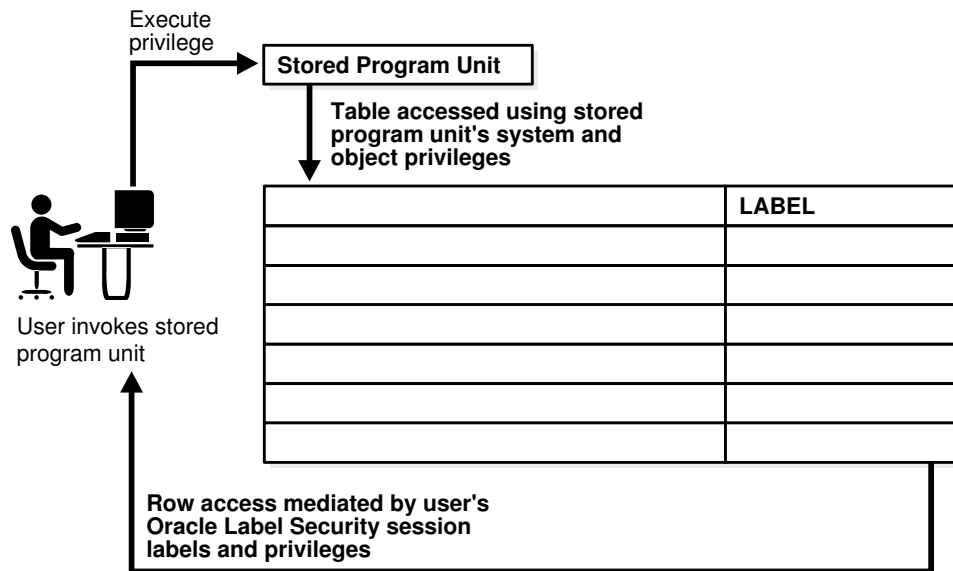

Stored program units can become *trusted* when an administrator assigns them Oracle Label Security privileges. A stored program unit can be run with its own autonomous Oracle Label Security privileges rather than those of the user who calls it. For example, if you possess no Oracle Label Security privileges in your own right but run a stored program unit that has the `WRITEDOWN` privilege, then you can update labels. In this case, the privileges used are those of the stored program unit, and not your own.

Trusted program units can encapsulate privileged operations in a controlled manner. By using procedures, packages, and functions with assigned privileges, you may be able to access data that your own labels and privileges would not authorize. For example, to perform aggregate functions over all data in a table, not just the data visible to you, you might use a trusted program set up by an administrator. This way program units can thus perform operations on behalf of users, without the need to grant privileges directly to users.

Related Topics

- [Administering and Using Trusted Stored Program Units](#)
You can use trusted stored program units to enhance system security.

Access Mediation and Policy Enforcement Options

An administrator can choose from among a set of policy enforcement options when applying an Oracle Label Security policy to individual tables.

These options enable enforcement to be tailored differently for each database table. In addition to the access controls based on the labels, a SQL predicate can also be associated with each table. The predicate can further define which rows in the table are accessible to the user.

In cases where the label to be associated with a new or updated row should be automatically computed, an administrator can specify a labeling function when applying the policy. That function will thereafter always be invoked to provide the data

labels written under that policy, because active labeling functions take precedence over any alternative means of supplying a label.

Except where noted, this guide assumes that all enforcement options are in effect.

Related Topics

- [Implementing Policy Enforcement Options and Labeling Functions](#)
You can customize the enforcement of Oracle Label Security policies and implement labeling functions.
- [Labeling Functions](#)
Labeling functions can compute and return a label using resources such as context variables (for example, date or username) and data values.
- [SA_POLICY_ADMIN.APPLY_SCHEMA_POLICY](#)
The `SA_POLICY_ADMIN.APPLY_SCHEMA_POLICY` procedure applies a policy to all of the tables in a schema and enables the policy for these tables.

Working with Multiple Oracle Label Security Policies

You can use multiple Oracle Label Security policies in both a single database environments and in a distributed environments.

- [Multiple Oracle Label Security Policies in a Single Database](#)
Several Oracle Label Security policies can protect data in a single database.
- [Multiple Oracle Label Security Policies in a Distributed Environment](#)
In a distributed environment that uses Oracle Label Security, remote connections are controlled by Oracle Label Security.

Multiple Oracle Label Security Policies in a Single Database

Several Oracle Label Security policies can protect data in a single database.

Each defined policy is associated with a set of labels used only by that policy. Data labels are constrained by the set of defined labels for each policy.

Each policy may protect a different table, but multiple policies can also apply to a single table. To access data, you must have label authorizations for all policies protecting that data. To access any particular row, you must be authorized by *all* policies protecting the table containing your desired rows. If you require privileges, then you may need privileges for all of the policies affecting your work.

Multiple Oracle Label Security Policies in a Distributed Environment

In a distributed environment that uses Oracle Label Security, remote connections are controlled by Oracle Label Security.

Related Topics

- [Using Oracle Label Security with a Distributed Database](#)
You should understand the special considerations for using Oracle Label Security in a distributed configuration.

Part II

Using Oracle Label Security Functionality

Part II explains how to work with Oracle Label Security functionality.

- [Getting Started with Oracle Label Security](#)
Before using Oracle Label Security, you must register it with the database and then enable the `LBACSYS` Oracle Label Security account.
- [Creating an Oracle Label Security Policy](#)
An Oracle Label Security policy is a named set of commands that implements Oracle Label Security.
- [Working with Labeled Data](#)
You can manage labeled data, view that data of security attributes for a session, and change the value of session attributes.
- [Oracle Label Security Using Oracle Internet Directory](#)
You can use Oracle Label Security with Oracle Internet Directory.

4

Getting Started with Oracle Label Security

Before using Oracle Label Security, you must register it with the database and then enable the `LBACSYS` Oracle Label Security account.

- [Registering Oracle Label Security with an Oracle Database](#)
You must register Oracle Label Security with the database in which you plan to use it.
- [Enabling the LBACSYS Oracle Label Security Account](#)
After you complete the registration process, the default user account, `LBACSYS`, is granted the `LBAC_DBA` database role, which provides the privileges necessary to manage Oracle Label Security.
- [Logging in to Cloud Control or SQL*Plus for Oracle Label Security](#)
After you complete the Oracle Label Security registration and enablement process, you can begin using it.

Registering Oracle Label Security with an Oracle Database

You must register Oracle Label Security with the database in which you plan to use it.

- [About Registering Oracle Label Security](#)
When you install Oracle Database, by default Oracle Label Security is not enabled.
- [Checking if Oracle Label Security Has Been Registered and Enabled](#)
You can query the `DBA_OLS_STATUS` and `CDB_OLS_STATUS` data dictionary views to find if Oracle Label Security has already been registered and enabled.
- [Registering and Enabling Oracle Label Security from SQL*Plus](#)
You can both register and enable Oracle Label Security from SQL*Plus.
- [Registering and Enabling Oracle Label Security Using DBCA](#)
You can both register and enable Oracle Label Security using Database Configuration Assistant.

About Registering Oracle Label Security

When you install Oracle Database, by default Oracle Label Security is not enabled.

You must register Oracle Label Security with the database. Afterwards, you must enable the default Oracle Label Security user account, `LBACSYS`. After you register Oracle Label Security, you can disable and re-enable it when necessary.

If you are using a multitenant environment, then only register Oracle Label Security in the pluggable databases (PDBs) in which you plan to create Oracle Label Security policies. Because Oracle Label Security is not designed to protect data dictionary objects, you cannot create policies in the root.

Checking if Oracle Label Security Has Been Registered and Enabled

You can query the `DBA_OLS_STATUS` and `CDB_OLS_STATUS` data dictionary views to find if Oracle Label Security has already been registered and enabled.

1. Log into the database instance as user `SYS` with the `SYSDBA` administrative privilege.

```
sqlplus sys as sysdba
Enter password: password
```

2. If you are using a multitenant environment, then connect to the appropriate PDB.

For example, to connect to the PDB `hrpdb`:

```
CONNECT SYS@hrpdb AS SYSDBA
Enter password: password
```

To find the available PDBs, query the `DBA_PDBS` data dictionary view. To check the current PDB, run the `show con_name` command.

3. Run the appropriate query to find if Oracle Label Security has been registered (configured) and enabled.

- If you want to find the Oracle Label Security status for a non-multitenant database, or in a multitenant environment for the root only or an individual PDB, then query `DBA_OLS_STATUS`. For example:

```
SELECT * FROM DBA_OLS_STATUS;
```

| NAME | STATUS | DESCRIPTION |
|----------------------|--------|---------------------------------------|
| OLS_CONFIGURE_STATUS | TRUE | Determines if OLS is configured |
| OLS_DIRECTORY_STATUS | FALSE | Determines if OID is enabled with OLS |
| OLS_ENABLE_STATUS | TRUE | Determines if OLS is enabled |

- If you want to find the Oracle Label Security status of all PDBs in a multitenant environment, as a common user with administrative privileges, then query `CDB_OLS_STATUS`. For example:

```
SELECT * FROM CDB_OLS_STATUS;
```

| NAME | STATUS | DESCRIPTION | |
|----------------------|--------|---------------------------------------|---|
| CON_ID | | | |
| OLS_DIRECTORY_STATUS | FALSE | Determines if OID is enabled with OLS | 4 |
| OLS_ENABLE_STATUS | TRUE | Determines if OLS is enabled | 4 |
| OLS_CONFIGURE_STATUS | TRUE | Determines if OLS is configured | 4 |
| OLS_DIRECTORY_STATUS | FALSE | Determines if OID is enabled with OLS | 5 |
| OLS_ENABLE_STATUS | TRUE | Determines if OLS is enabled | 5 |
| OLS_CONFIGURE_STATUS | TRUE | Determines if OLS is configured | 5 |

Registering and Enabling Oracle Label Security from SQL*Plus

You can both register and enable Oracle Label Security from SQL*Plus.

1. Log into the database instance as user `SYS` with the `SYSDBA` administrative privilege.

For example:

```
sqlplus sys as sysdba
Enter password: password
```

2. If you are using a multitenant environment, then connect to the appropriate PDB.

For example, to connect to the PDB `hrpdb`:

```
CONNECT SYS@hrpdb AS SYSDBA
Enter password: password
```

To find the available PDBs, query the `DBA_PDBS` data dictionary view. To check the current PDB, run the `show con_name` command.

3. Register and enable Oracle Label Security as follows.

```
EXEC LBACSYS.CONFIGURE_OLS; -- This procedure registers Oracle Label Security.
EXEC LBACSYS.OLS_ENFORCEMENT.ENABLE_OLS; -- This procedure enables it.
```

4. Connect as user `SYS` with the `SYSOPER` privilege.

```
CONNECT SYS AS SYSOPER -- Or, CONNECT SYS@hrpdb AS SYSOPER
Enter password: password
```

5. Restart the database.

For example:

```
SHUTDOWN IMMEDIATE
STARTUP
```

Registering and Enabling Oracle Label Security Using DBCA

You can both register and enable Oracle Label Security using Database Configuration Assistant.

1. Start Database Configuration Assistant (DBCA).

- **UNIX:** Run the following command:

```
$ORACLE_HOME/bin/dbca
```

- **Windows:** From the **Start** menu, click **All Programs**. Then click **Oracle - ORACLE_HOME**, then **Configuration and Migration Tools**, and then **Database Configuration Assistant**.

The Welcome screen appears.

2. Click **Next**.

The Operations screen appears.

3. Select **Configure Database Options**. Click **Next**.

The Database screen appears.

4. From the list, select the database where you need to configure and enable OLS. Click **Next**.

The Database Content screen appears.

5. Select **Oracle Label Security**. Click **Next**.

The Connection Mode screen appears.

6. Select either **Dedicated Server Mode** or **Shared Server Mode**. Click **Finish**.

A dialog box is displayed informing you that the operation will require the database to be restarted.

7. Click **OK**.
A confirmation dialog box is displayed.
8. Click **OK**.
The DBCA progress screen is displayed.
9. After the operation is complete, you are prompted to perform another operation.
Click **No** to exit DBCA.

Enabling the LBACSYS Oracle Label Security Account

After you complete the registration process, the default user account, `LBACSYS`, is granted the `LBAC_DBA` database role, which provides the privileges necessary to manage Oracle Label Security.

By default, `LBACSYS` is created as a schema only account. It is a locked account with no password.

1. Log into the database instance as a user who has been granted the `ALTER USER` system privilege (for example, a named user who has been granted this privilege).

For example:

```
sqlplus sec_admin -- Or, sqlplus sec_admin@hrpdb for the hrpdb pluggable
database (PDB)
Enter password: password
```

If Oracle Database Vault is enabled, then log in as a user who has been granted the `DV_ACCTMGR` role.

2. Enter this statement:

```
ALTER USER LBACSYS ACCOUNT UNLOCK IDENTIFIED BY password;
```

Replace `password` with a password that is secure. See *Oracle Database Security Guide* for the minimum requirements for creating passwords.

After you unlock user `LBACSYS` and provide a password, as a good practice, for day-to-day use, grant the `LBAC_DBA` database role to trusted users who will administer Oracle Label Security. Then, as a best security practice, use the `ALTER` statement to lock the `LBACSYS` account back to schema only account. After the `LBAC_DBA` role has been granted, then use the `ALTER USER` statement as follows:

```
ALTER USER LBACSYS NO AUTHENTICATION;
```

This way, the `LBACSYS` account is protected and does not require password maintenance.

If you plan to use Enterprise Manager Cloud Control to administer Oracle Label Security, then ensure that any users to whom you have granted the `LBAC_DBA` role also have the `SELECT ANY DICTIONARY` privilege. By default, the `LBACSYS` account already has this privilege.

Logging in to Cloud Control or SQL*Plus for Oracle Label Security

After you complete the Oracle Label Security registration and enablement process, you can begin using it.

- [Logging in to Oracle Label Security from Enterprise Manager Cloud Control](#)
From Enterprise Manager Cloud Control, you use the Oracle Label Security pages to create and manage Oracle Label Security policies.
- [Logging in to Oracle Label Security from SQL*Plus](#)
You can log in to Oracle Label Security from SQL*Plus if you have been granted the `LBAC_DBA` database role.

Logging in to Oracle Label Security from Enterprise Manager Cloud Control

From Enterprise Manager Cloud Control, you use the Oracle Label Security pages to create and manage Oracle Label Security policies.

1. Ensure that you have configured the Cloud Control target databases that you plan to use with Oracle Label Security.

See the Oracle Enterprise Manager online help and *Oracle Database Enterprise User Security Administrator's Guide* for more information about configuring target databases.

2. Point your browser to the Cloud Control login page.

For example:

```
https://myserver.example.com:7799/em
```

3. Log into Cloud Control as user `SYSMAN`.
4. In the Cloud Control home page, from the **Targets** menu, select **Databases**.
5. In the Databases page, select the link for the database to which you want to connect.

The Database home page appears.

6. From the **Security** menu, select **Label Security**.

The Database Login page appears.

7. Enter the following information:

- **Username:** Enter the user name of a user who has been granted the `LBAC_DBA` database role, or enter `LBACSYS`.
- **Password:** Enter the password.
- **Role:** Select **NORMAL** from the list.
- **Save As:** Select this check box if you want these credentials to be automatically filled in for you the next time that this page appears. The credentials are stored in Enterprise Manager in a secured manner. Access to these credentials depends on the user who is currently logged in.

Logging in to Oracle Label Security from SQL*Plus

You can log in to Oracle Label Security from SQL*Plus if you have been granted the `LBAC_DBA` database role.

- To use Oracle Label Security from SQL*Plus, connect as user `LBACSYS` or as a user who has been granted the `LBAC_DBA` database role. To find if a user has been granted this role, query the `GRANTEE` and `GRANTED_ROLE` columns of the `DBA_ROLE_PRIVS` data dictionary view.

For example:

```
sqlplus psmith_ols -- Or, sqlplus psmith_ols@hrpdb for a PDB named hrpdb  
Enter password: password
```

To find the available PDBs, query the `DBA_PDBS` data dictionary view. To check the current PDB, run the `show con_name` command.

5

Creating an Oracle Label Security Policy

An Oracle Label Security policy is a named set of commands that implements Oracle Label Security.

- [About Creating Oracle Label Security Policies](#)
When you create an Oracle Label Security policy, you must follow a set of general steps.
- [Step 1: Create the Label Security Policy Container](#)
The Oracle Label Security policy container is a storage place for the policy settings.
- [Step 2: Create Data Labels for the Label Security Policy](#)
After you create a policy container, you are ready to create data labels for each database table row.
- [Step 3: Authorize Users for the Label Security Policy](#)
Before users can have access to data that is protected by an Oracle Label Security policy, they must be authorized.
- [Step 4: Grant Privileges to Users and Trusted Stored Program Units](#)
You can grant privileges to users, such as `READ` so that users can read data protected an Oracle Label Security policy protects.
- [Step 5: Apply the Policy to a Database Table or Schema](#)
After you create grant authorizations and privileges to an Oracle Label Security policy, you can apply it to a database table or schema.
- [Step 6: Add Policy Labels to Table Rows](#)
You must add policy labels to table rows.
- [Step 7: \(Optional\) Configure Auditing](#)
You can audit Oracle Label Security policies by using the `SA_USER_ADMIN` P/L SQL package.
- [Using Enterprise Manager Cloud Control to Create an OLS Policy](#)
You can create Oracle Label Security policies in Oracle Enterprise Manager Cloud Control.

About Creating Oracle Label Security Policies

When you create an Oracle Label Security policy, you must follow a set of general steps.

1. Create a policy container that defines the policy name, the name of a column that Oracle Label Security will add to the tables to be protected, whether to hide this column, whether to enable the policy, and default enforcement options for the policy.

See [Step 1: Create the Label Security Policy Container](#) for more information.
2. Define the following attributes for the label: level of sensitivity, and optionally, compartments and groups to further filter the label sensitivity. Once you have the

attributes defined, create the label itself and then associate these attributes with the label.

See [Step 2: Create Data Labels for the Label Security Policy](#).

3. Authorize users for the policy.

See [Step 3: Authorize Users for the Label Security Policy](#) for more information.

4. Grant privileges to these users or to trusted program units.

See [Step 4: Grant Privileges to Users and Trusted Stored Program Units](#) for more information.

5. Apply the policy to a database table. Alternatively, you can apply the policy to an entire schema.

See [Step 5: Apply the Policy to a Database Table or Schema](#) for more information.

6. Add the policy labels to the table rows. You must update the table that is being used for the policy.

See [Step 6: Add Policy Labels to Table Rows](#) for more information.

7. Optionally, configure audit settings for users.

See [Step 7: \(Optional\) Configure Auditing](#) for more information.

Step 1: Create the Label Security Policy Container

The Oracle Label Security policy container is a storage place for the policy settings.

- [About the Label Security Policy Container](#)
The Oracle Label Security policy container stores metadata that describes how the policy behaves.
- [Creating a Label Policy Container](#)
You can use the `SA_SYSDBA.CREATE_POLICY` procedure to create an Oracle Label Security policy container.

About the Label Security Policy Container

The Oracle Label Security policy container stores metadata that describes how the policy behaves.

This container defines the policy name, the name of a column that Oracle Label Security will add to the tables to be protected, whether to hide this column, and default enforcement options for the policy.

The column that you add to the tables that you want to protect will include data labels (which you create later on) that are assigned to specific rows in a the table, based on values in a specific column. The policy creation process creates a special role for the policy and grants this role to the user who creates the policy. The role name is in the format `policy_DBA`. For example, for a policy named `EMP_OLS_POL`, the role name is `EMP_OLS_POL_DBA`. This role becomes effective only after a new user session begins.

You can create the policy container in Oracle Enterprise Manager Cloud Control, or use the `SA_SYSDBA.CREATE_POLICY` procedure.

Creating a Label Policy Container

You can use the `SA_SYSDBA.CREATE_POLICY` procedure to create an Oracle Label Security policy container.

- To create the policy, run `SA_SYSDBA.CREATE_POLICY`, specifying the policy name, column name, and default options.

For example:

```
BEGIN
SA_SYSDBA.CREATE_POLICY (
  policy_name      => 'emp_ols_pol',
  column_name      => 'ols_col',
  default_options  => 'read_control, update_control');
END;
/
```

Related Topics

- [SA_SYSDBA.CREATE_POLICY](#)
The `SA_SYSDBA.CREATE_POLICY` procedure creates a new Oracle Label Security policy, defines a policy-specific column name, and specifies default policy options.

Step 2: Create Data Labels for the Label Security Policy

After you create a policy container, you are ready to create data labels for each database table row.

- [About Data Labels](#)
A data label indicates the sensitivity of a database table row.
- [About Policy Level Sensitivity Components](#)
A *level* is a ranking that denotes the sensitivity of the information it labels.
- [Creating a Policy Level Component](#)
The `SA_COMPONENTS.CREATE_LEVEL` procedure creates a policy level component.
- [About Policy Compartment Components](#)
Compartments identify areas that describe the sensitivity of the labeled data, providing a finer level of granularity within a level.
- [Creating a Policy Compartment Component](#)
The `SA_COMPONENTS.CREATE_COMPARTMENT` procedure creates an Oracle Label Security compartment.
- [About Policy Group Components](#)
Groups identify organizations owning or accessing the data, such as `EASTERN_REGION`, `WESTERN_REGION`, `WR_SALES`.
- [Creating a Policy Data Label Group](#)
The `SA_COMPONENTS.CREATE_GROUP` procedure creates a data label group.
- [About Associating the Policy Components with a Named Data Label](#)
After defining the data label components, you can create a data label itself by associating it with an existing level.
- [Associating the Policy Components with a Named Data Label](#)
The `SA_LABEL_ADMIN.CREATE_LABEL` procedure creates a data label.

About Data Labels

A data label indicates the sensitivity of a database table row.

Each label is a single attribute with multiple components that control the types of filtering to be used for user access.

[Table 5-1](#) describes the different components of a data label.

Table 5-1 Sensitivity Data Label Components

| Component | Description | Examples |
|--------------|--|---|
| Level | A single specification of the sensitivity of labeled data within the ordered ranks established | CONFIDENTIAL (1), SENSITIVE (2), HIGHLY_SENSITIVE (3) |
| Compartments | Zero or more categories associated with the labeled data | FINANCIAL, STRATEGIC, NUCLEAR |
| Groups | Zero or more identifiers for organizations owning or accessing the data | EASTERN_REGION, WESTERN_REGION |

All data labels must contain a level component, but the compartment and group components are optional. Compartments and groups are a way of fine tuning access that users will have to the data. Valid characters for specifying all label components include alphanumeric characters, underscores, and spaces. (Leading and trailing spaces are ignored.) You must define the label components before you can create the data label itself.

You can use Cloud Control to create the label and its components for an existing policy. Alternatively, you can use the `SA_COMPONENTS` PL/SQL package to create the components, and the `SA_LABEL_ADMIN` package to create the data label.

Related Topics

- [SA_COMPONENTS Label Components PL/SQL Package](#)
The `SA_COMPONENTS` PL/SQL package manages the component definitions of an Oracle Label Security label.

About Policy Level Sensitivity Components

A *level* is a ranking that denotes the sensitivity of the information it labels.

The more sensitive the information, the higher its level. The less sensitive the information, the lower its level.

Every label must include one level. Oracle Label Security permits up to 10,000 levels in a policy. For each level, you must define a numeric form, a long character form, and the required short character form.

[Table 5-2](#) shows examples of levels.

Table 5-2 Policy Level Example

| Numeric Form | Long Form | Short Form |
|--------------|------------------|------------|
| 40 | HIGHLY_SENSITIVE | HS |
| 30 | SENSITIVE | S |
| 20 | CONFIDENTIAL | C |
| 10 | PUBLIC | P |

Table 5-2 explains the numeric form, long form, and short form for levels.

Table 5-3 Forms of Specifying Levels

| Form | Explanation |
|---------------------------------|---|
| Numeric form, also called "tag" | The numeric form of the level can range from 0 to 9999. Sensitivity is ranked by this numeric value, so you must assign higher numbers to levels that are more sensitive, and lower numbers to levels that are less sensitive. In Table 5-2, 40 (HIGHLY_SENSITIVE) is a higher level than 30, 20, and 10. Administrators should avoid using sequential numbers for the numeric form of levels. A good strategy is to use even increments (such as 50 or 100) between levels. You can then insert additional levels between two preexisting levels, at a later date. |
| Long form | The long form of the level name can contain up to 80 characters. |
| Short form | The short form can contain up to 30 characters. |

Although you define both long and short names for the level (and for each of the other label components), only the short form of the name is displayed upon retrieval. When users manipulate the labels, they use only the short form of the component names.

Examples of levels can be names such as TOP_SECRET, SECRET, CONFIDENTIAL, and UNCLASSIFIED OR TRADE_SECRET, PROPRIETARY, COMPANY_CONFIDENTIAL, PUBLIC_DOMAIN.

If you use only levels, a level 40 user (in this example) can access or alter any data row whose level is 40 or less.

Creating a Policy Level Component

The SA_COMPONENTS.CREATE_LEVEL procedure creates a policy level component.

- To create the policy level component, run SA_COMPONENTS.CREATE_LEVEL, specifying the policy name and details about the component.

For example:

```
BEGIN
  SA_COMPONENTS.CREATE_LEVEL (
    policy_name => 'emp_ols_pol',
    level_num   => 40,
    short_name  => 'HS',
    long_name   => 'HIGHLY_SENSITIVE');
END;
/
```

Related Topics

- [SA_COMPONENTS.CREATE_LEVEL](#)

The `SA_COMPONENTS.CREATE_LEVEL` procedure creates a level and specify its short name and long name.

About Policy Compartment Components

Compartments identify areas that describe the sensitivity of the labeled data, providing a finer level of granularity within a level.

Compartments associate the data with one or more security areas. All data related to a particular project can be labeled with the same compartment.

[Table 5-4](#) shows an example set of compartments.

Table 5-4 Policy Compartment Example

| Numeric Form | Long Form | Short Form |
|--------------|-------------|------------|
| 85 | FINANCIAL | FINCL |
| 65 | CHEMICAL | CHEM |
| 45 | OPERATIONAL | OP |

[Table 5-5](#) shows different ways to specify compartments.

Table 5-5 Forms of Specifying Compartments

| Form | Explanation |
|--------------|--|
| Numeric form | <p>The numeric form can range from 0 to 9999. It is unrelated to the numbers used for the levels. The numeric form of the compartment does not indicate greater or less sensitivity. Instead, it controls the display order of the short form compartment name in the label character string. For example, assume a label is created that has all three compartments listed in Table 5-4, and a level of <code>SENSITIVE</code>. When this label is displayed in string format, it looks like this:</p> <pre>S:OP,CHEM,FINCL</pre> <p>meaning <code>SENSITIVE: OPERATIONAL, CHEMICAL, FINANCIAL</code></p> <p>The display order follows the order of the numbers assigned to the compartments: 45 is lower than 65, and 65 is lower than 85. By contrast, if the number assigned to the <code>FINCL</code> compartment were 5, the character string format of the label would look like this:</p> <pre>S:FINCL,OP,CHEM</pre> |
| Long form | The long form of the compartment name can have up to 80 characters. |
| Short form | The short form can contain up to 30 characters. |

Compartments are optional. You can include up to 10,000 compartments for a label.

Not all labels must have compartments. For example, you can specify `HIGHLY_SENSITIVE` and `CONFIDENTIAL` levels with no compartments, and a `SENSITIVE` level that does contain compartments.

When you analyze the sensitivity of data, you may find that some compartments are only useful at specific levels.

Figure 5-1 shows how compartments can be used to categorize data.

Figure 5-1 Compartments in a Label

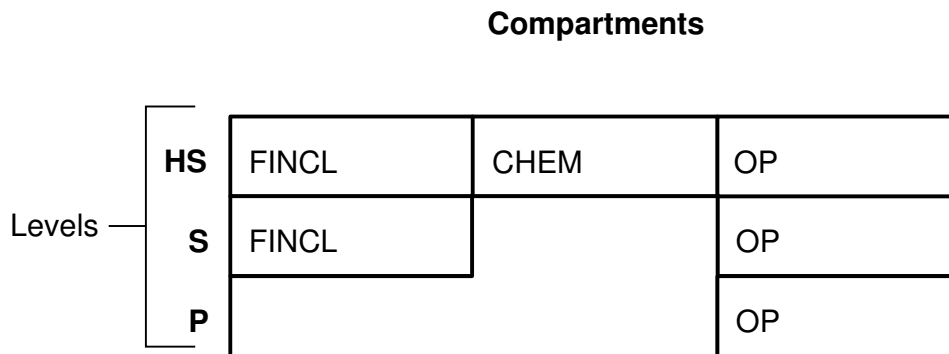

Here, compartments `FINCL`, `CHEM`, and `OP` are used with the level `HIGHLY_SENSITIVE` (`HS`). The label `HIGHLY_SENSITIVE.FINCL, CHEM` indicates a level of 40 with the two named compartments. Compartment `FINCL` is not more sensitive than `CHEM`, nor is `CHEM` more sensitive than `FINCL`. Note also that some data in the protected table may not belong to any compartment.

If you specify compartments, then a user whose level would normally permit access to a row's data will nevertheless be prevented from such access unless the user's label also contains all the compartments appearing in that row's label. For example, user `hpreston`, who is granted access to the `HS` level, could be granted access only to `FINCL` and `CHEM` but not to `OP`.

Creating a Policy Compartment Component

The `SA_COMPONENTS.CREATE_COMPARTMENT` procedure creates an Oracle Label Security compartment.

- To create the compartment, run the `SA_COMPONENTS.CREATE_COMPARTMENT` procedure to create a compartment, specifying the policy name and details about the compartment.

For example:

```
BEGIN
  SA_COMPONENTS.CREATE_COMPARTMENT (
    policy_name => 'emp_ols_pol',
    comp_num    => '85',
    short_name  => 'FINCL',
    long_name   => 'FINANCIAL');
END;
/
```

Related Topics

- [SA_COMPONENTS.CREATE_COMPARTMENT](#)
The `SA_COMPONENTS.CREATE_COMPARTMENT` procedure creates a compartment and specify its short name and long name.

About Policy Group Components

Groups identify organizations owning or accessing the data, such as `EASTERN_REGION`, `WESTERN_REGION`, `WR_SALES`.

All data pertaining to a certain department can have that department's group in the label. Groups are useful for the controlled dissemination of data and for timely reaction to organizational change. When a company reorganizes, data access can change right along with the reorganization.

Groups are hierarchical. You can label data based upon your organizational infrastructure. A group can thus be associated with a parent group.

Figure 5-2 shows how you can define a set of groups corresponding to the following organizational hierarchy.

Figure 5-2 Group Example

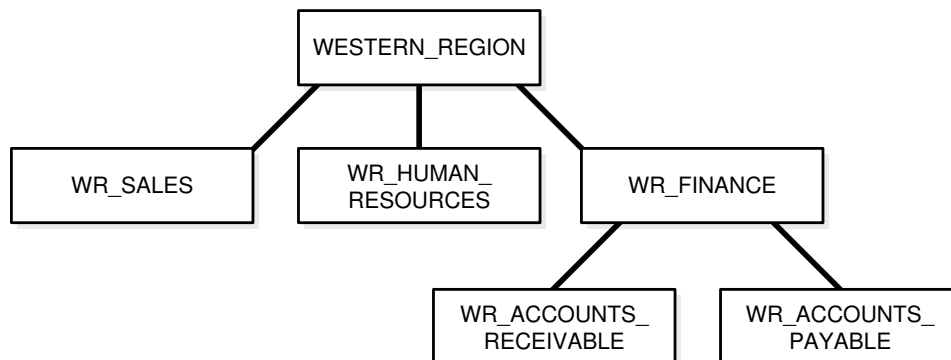

The `WESTERN_REGION` group includes three subgroups: `WR_SALES`, `WR_HUMAN_RESOURCES`, and `WR_FINANCE`. The `WR_FINANCE` subgroup is subdivided into `WR_ACCOUNTS_RECEIVABLE` and `WR_ACCOUNTS_PAYABLE`.

Table 5-6 shows how the organizational structure in this example can be expressed in the form of Oracle Label Security groups. The numeric form assigned to the groups affects display order only. You specify the hierarchy (that is, the parent and child relationships) separately. The first group listed, `WESTERN_REGION`, is the parent group of the remaining groups in the table.

Table 5-6 Group Example

| Numeric Form | Long Form | Short Form | Parent Group |
|--------------|--------------------|------------|--------------|
| 1000 | WESTERN_REGION | WR | |
| 1100 | WR_SALES | WR_SAL | WR |
| 1200 | WR_HUMAN_RESOURCES | WR_HR | WR |

Table 5-6 (Cont.) Group Example

| Numeric Form | Long Form | Short Form | Parent Group |
|--------------|------------------------|------------|--------------|
| 1300 | WR_FINANCE | WR_FIN | WR |
| 1310 | WR_ACCOUNTS_PAYABLE | WR_AP | WR_FIN |
| 1320 | WR_ACCOUNTS_RECEIVABLE | WR_AR | WR_FIN |

[Table 5-7](#) shows the forms that you must use when you specify groups.

Table 5-7 Forms of Specifying Groups

| Form | Explanation |
|--------------|--|
| Numeric form | <p>The numeric form of the group can range from 0 to 9999, and it must be unique for each policy.</p> <p>The numeric form does not indicate any kind of ranking. It does not indicate a parent-child relationship, or greater or less sensitivity. It only controls the display order of the short form group name in the label character string.</p> <p>For example, assume that a label is created that has the level <code>SENSITIVE</code>, the compartment <code>CHEMICAL</code>, and the groups <code>WESTERN_REGION</code> and <code>WR_HUMAN_RESOURCES</code> as listed in Table 5-6. When displayed in string format, the label looks like this:</p> <pre>S:CHEM:WR,WR_HR</pre> <p><code>WR</code> is displayed before <code>WR_HR</code> because 1000 comes before 1200.</p> |
| Long form | The long form of the group name can contain up to 80 characters. |
| Short form | The short form can contain up to 30 characters. |

Groups are optional. A label can contain up to 10,000 groups.

All labels do not need to have groups. When you analyze the sensitivity of data, you may find that some groups are only used at specific levels. For example, you can specify `HIGHLY_SENSITIVE` and `CONFIDENTIAL` labels with no groups, and a `SENSITIVE` label that does contain groups.

Creating a Policy Data Label Group

The `SA_COMPONENTS.CREATE_GROUP` procedure creates a data label group.

- Run the `SA_COMPONENTS.CREATE_GROUP` procedure for each data label group that you need.

In the following example, the first `CREATE_GROUP` procedure creates the parent group, `WR`, and the second procedure associates a second group with the `WR` group by using the `parent_name` parameter.

```
BEGIN
SA_COMPONENTS.CREATE_GROUP (
  policy_name => 'emp_ols_pol',
  group_num   => 1000,
  short_name  => 'WR',
  long_name   => 'WESTERN_REGION');
```

```

END;
/
BEGIN
  SA_COMPONENTS.CREATE_GROUP (
    policy_name      => 'emp_ols_pol',
    group_num        => 1100,
    short_name       => 'WR_SAL',
    long_name        => 'WR_SALES',
    parent_name      => 'WR');
END;
/

```

Related Topics

- [SA_COMPONENTS.CREATE_GROUP](#)

The `SA_COMPONENTS.CREATE_GROUP` procedure creates a group and specifies its short name and long name, and optionally a parent group.

About Associating the Policy Components with a Named Data Label

After defining the data label components, you can create a data label itself by associating it with an existing level.

Optionally, you can include compartments and groups in this association.

You can use Oracle Enterprise Manager Cloud Control or the `SA_LABEL_ADMIN.CREATE_LABEL` procedure. Character string representations of labels use the following syntax:

```
level:compartment1,...,compartmentn:group1,...,groupn
```

The text string that specifies the label can have a maximum of 4,000 characters, including alphanumeric characters, spaces, and underscores. The label names are case-insensitive. You can enter them in uppercase, lowercase, or mixed case, but the string is stored in the data dictionary and displayed in uppercase. Separate each set of components with a colon. You do not need to enter trailing delimiters in this syntax.

For example, you can create valid labels such as these:

```

SENSITIVE:FINANCIAL,CHEMICAL:EASTERN_REGION,WESTERN_REGION
CONFIDENTIAL:FINANCIAL:VP_GRP
SENSITIVE
HIGHLY_SENSITIVE:FINANCIAL
SENSITIVE::WESTERN_REGION

```

Associating the Policy Components with a Named Data Label

The `SA_LABEL_ADMIN.CREATE_LABEL` procedure creates a data label.

- Run `SA_LABEL_ADMIN.CREATE_LABEL`, specifying the policy name and details about the policy components.

For example:

```

BEGIN
  SA_LABEL_ADMIN.CREATE_LABEL (
    policy_name      => 'emp_ols_pol',
    label_tag        => '1310',
    label_value      => 'SENSITIVE:FINANCIAL,CHEMICAL:EASTERN_REGION,WESTERN_REGION',
    data_label       => TRUE);

```

```
END;
/
```

When you create a data label, two additional actions occur:

- The label is automatically designated as a valid data label. This functionality limits the labels that can be assigned to data. Oracle Label Security can also create valid data labels dynamically at run time, from those that are predefined in Oracle Internet Directory. Most users, however, prefer to create the labels manually in order to limit data label proliferation.
- A numeric label tag is associated with the text string representing the label. It is this label tag, rather than the text string, that is stored in the policy label column of the protected table.

 **Note:**

For Oracle Label Security installations that do not use Oracle Internet Directory, dynamic creation of valid data labels uses the `TO_DATA_LABEL` function. Its usage should be tightly controlled.

Related Topics

- [Inserting Labels Using TO_DATA_LABEL](#)
The `TO_DATA_LABEL` function can generate new labels dynamically.
- [SA_LABEL_ADMIN.CREATE_LABEL](#)
The `SA_LABEL_ADMIN.CREATE_LABEL` procedure creates data labels.

Step 3: Authorize Users for the Label Security Policy

Before users can have access to data that is protected by an Oracle Label Security policy, they must be authorized.

- [About Authorizing Users for Label Security Policies](#)
When you authorize users, you enable them to have access to row data based on how the data labels are defined.
- [About Authorizing Levels](#)
You can explicitly set default, minimum, and maximum authorization levels.
- [Authorizing a Level](#)
The `SA_USER_ADMIN.SET_LEVELS` procedure authorizes users for policy levels components.
- [About Authorizing Compartments](#)
After you authorize the user for a specific level, optionally you can specify compartments to be added to a session label.
- [Authorizing a Compartment](#)
The `SA_USER_ADMIN.SET_COMPARTMENTS` procedure authorizes a user for the compartments component.
- [About Authorizing Groups](#)
You can specify the list of groups that a user can place in session label.
- [Authorizing a Group](#)
The `SA_USER_ADMIN.SET_GROUPS` procedure authorizes users for a policy group.

About Authorizing Users for Label Security Policies

When you authorize users, you enable them to have access to row data based on how the data labels are defined.

First, you set the user's authorization for each level, compartment, and group that is associated with the label. You can find the currently granted privileges for a user by querying the `DBA_SA_USER_PRIVS` data dictionary view.

About Authorizing Levels

You can explicitly set default, minimum, and maximum authorization levels.

Table 5-8 Authorized Levels Set by the Administrator

| Authorization | Meaning |
|------------------------|--|
| User Max Level | The maximum ranking of sensitivity that a user can access during read and write operations |
| User Min Level | The minimum ranking of sensitivity that a user can access during write operations. The User Max Level must be equal to or greater than the User Min Level. |
| User Default Level | The level that is assumed by default when connecting to Oracle Database |
| User Default Row Level | The level that is used by default when inserting data into Oracle Database |

For example, you might set the following level authorizations for user `hpreston`:

| Type | Short Name | Long Name | Description |
|---------|------------|------------------|----------------------|
| Maximum | HS | HIGHLY_SENSITIVE | User's highest level |
| Minimum | P | PUBLIC | User's lowest level |
| Default | C | CONFIDENTIAL | User's default level |
| Row | C | CONFIDENTIAL | Row level on INSERT |

Authorizing a Level

The `SA_USER_ADMIN.SET_LEVELS` procedure authorizes users for policy levels components.

Note that when you specify the levels, you must always use the short names, not the long names.

- Run `SA_USER_ADMIN.SET_LEVELS` to authorize the level, specifying the policy name, user name, and levels.

For example:

```
BEGIN
  SA_USER_ADMIN.SET_LEVELS (
    policy_name => 'ols_admin_pol',
```

```

user_name      => 'hpreston',
max_level      => 'HS',
min_level      => 'P',
def_level      => 'C',
row_level      => 'C');
END;
/

```

Related Topics

- [SA_USER_ADMIN.SET_LEVELS](#)

The `SA_USER_ADMIN.SET_LEVELS` procedure assigns a user minimum and maximum levels and identifies default values for the user's session label and row label.

About Authorizing Compartments

After you authorize the user for a specific level, optionally you can specify compartments to be added to a session label.

Write access must be explicitly given for each compartment. A user cannot directly insert, update, or delete a row that contains a compartment that the user does not have authorization to write.

For example, you could set the following compartment authorizations for user `hpreston`:

| Short Name | Long Name | WRITE | DEFAULT | ROW |
|------------|-------------|-------|---------|-----|
| CHEM | CHEMICAL | YES | YES | NO |
| FINCL | FINANCIAL | YES | YES | NO |
| OP | OPERATIONAL | YES | YES | YES |

Authorizing a Compartment

The `SA_USER_ADMIN.SET_COMPARTMENTS` procedure authorizes a user for the compartments component.

When you specify the compartments, you must use their short names, not their long names.

- Run `SA_USER_ADMIN.SET_COMPARTMENTS` to authorize a user for a compartment, specifying the policy name, user name, and compartment details.

For example:

```

BEGIN
SA_USER_ADMIN.SET_COMPARTMENTS (
  policy_name => 'ols_admin_pol',
  user_name   => 'hpreston',
  read_comps  => 'FINCL',
  write_comps => 'FINCL',
  def_comps   => 'FINCL',
  row_comps   => 'FINCL');
END;
/

```

After you have run this procedure, you can authorize the user for additional compartments by running the `SA_USER_ADMIN.ADD_COMPARTMENTS` procedure.

Related Topics

- [SA_USER_ADMIN.SET_COMPARTMENTS](#)
The `SA_USER_ADMIN.SET_COMPARTMENTS` procedure assigns compartments to a user and identifies default values for the user's session label and row label.
- [SA_USER_ADMIN.ADD_COMPARTMENTS](#)
The `SA_USER_ADMIN.ADD_COMPARTMENTS` procedure adds (assigns) compartments to a user's authorizations, indicating if the compartments are authorized for write and read privileges.

About Authorizing Groups

You can specify the list of groups that a user can place in session label.

Write access must be explicitly given for each group listed.

For example, you could set the following group authorizations:

| Short Name | Long Name | WRITE | DEFAULT | ROW | Parent |
|------------|------------------------|-------|---------|-----|--------|
| WR_HR | WR_HUMAN_RESOURCES | YES | YES | YES | WR |
| WR_AP | WR_ACCOUNTS_PAYABLE | YES | YES | NO | WR_FIN |
| WR_AR | WR_ACCOUNTS_RECEIVABLE | YES | YES | NO | WR_FIN |

Authorizing a Group

The `SA_USER_ADMIN.SET_GROUPS` procedure authorizes users for a policy group.

- Run `SA_USER_ADMIN.SET_GROUPS` to authorize the user, specifying the policy name, user name, and authorizations that you want. When you specify the groups, you must use the short name, not the long name.

For example:

```
BEGIN
  SA_USER_ADMIN.SET_GROUPS (
    policy_name => 'ols_admin_pol',
    user_name   => 'hpreston',
    read_groups => 'WR_AP',
    write_groups => 'WR_AP',
    def_groups  => 'WR_AP',
    row_groups  => 'WR_AP');
END;
/
```

Related Topics

- [SA_USER_ADMIN.SET_GROUPS](#)
The `SA_USER_ADMIN.SET_GROUPS` procedure assigns groups to a user and identifies default values for the user's session label and row label.

Step 4: Grant Privileges to Users and Trusted Stored Program Units

You can grant privileges to users, such as `READ` so that users can read data protected an Oracle Label Security policy protects.

- [About Granting Privileges to Users and Trusted Program Units for the Policy](#)
After you have authorized users for policy levels, compartments, and groups, you are ready to grant the user privileges.
- [Granting Privileges to a User](#)
The `SA_USER_ADMIN.SET_USER_PRIVS` procedure grants users privileges.
- [Granting Privileges to a Trusted Program Unit](#)
The `SA_USER_ADMIN.SET_PROG_PRIVS` procedure grants privileges to trusted program units.

About Granting Privileges to Users and Trusted Program Units for the Policy

After you have authorized users for policy levels, compartments, and groups, you are ready to grant the user privileges.

Trusted program units are functions, procedures, or packages that are granted Oracle Label Security privileges. You create a trusted stored program unit in the same way that you create a standard procedure, function, or package, that is by using the `CREATE PROCEDURE`, `CREATE FUNCTION`, or `CREATE PACKAGE` and `CREATE PACKAGE BODY` statements. The program unit becomes trusted when you grant Oracle Label Security privileges to it.

[Table 5-9](#) summarizes the privileges that can be granted to users or trusted stored program units.

Table 5-9 Oracle Label Security Privileges

| Security Privilege | Explanation |
|-----------------------------|---|
| <code>READ</code> | Allows read access to all data protected by the policy |
| <code>FULL</code> | Allows full read and write access to all data protected by the policy |
| <code>COMPACCESS</code> | Allows a session access to data authorized by the row's compartments, independent of the row's groups |
| <code>PROFILE_ACCESS</code> | Allows a session to change its labels and privileges to those of a different user |
| <code>WRITEUP</code> | Allows users to set or raise only the level, within a row label, up to the maximum level authorized for the user. (Active only if <code>LABEL_UPDATE</code> is active.) |

Table 5-9 (Cont.) Oracle Label Security Privileges

| Security Privilege | Explanation |
|--------------------|---|
| WRITEDOWN | Allows users to set or lower the level, within a row label, to any level equal to or greater than the minimum level authorized for the user. (Active only if LABEL_UPDATE is active.) |
| WRITEACROSS | Allows a user to set or change groups and compartments of a row label, but does not allow changes to the level. (Active only if LABEL_UPDATE is active.) |

Granting Privileges to a User

The `SA_USER_ADMIN.SET_USER_PRIVS` procedure grants users privileges.

- Run `SA_USER_ADMIN.SET_USER_PRIVS`, specifying the policy name, user name, and privileges that you want to grant.

For example:

```
BEGIN
  SA_USER_ADMIN.SET_USER_PRIVS(
    policy_name => 'ols_admin_pol',
    user_name   => 'hpreston',
    privileges  => 'WRITEDOWN');
END;
/
```

Related Topics

- [SA_USER_ADMIN.SET_USER_PRIVS](#)
The `SA_USER_ADMIN.SET_USER_PRIVS` procedure sets policy-specific privileges for users.

Granting Privileges to a Trusted Program Unit

The `SA_USER_ADMIN.SET_PROG_PRIVS` procedure grants privileges to trusted program units.

- Run `SA_USER_ADMIN.SET_PROG_PRIVS` to grant the privileges, specifying the policy name, schema name, program unit name, and privileges that you want to grant.

For example:

```
BEGIN
  SA_USER_ADMIN.SET_PROG_PRIVS (
    policy_name      => 'oe_ols_pol',
    schema_name     => 'oe',
    program_unit_name => 'check_order_updates',
    privileges       => 'READ');
END;
/
```

Related Topics

- [SA_USER_ADMIN.SET_PROG_PRIVS](#)
The `SA_USER_ADMIN.SET_PROG_PRIVS` procedure sets policy-specific privileges for program units.

Step 5: Apply the Policy to a Database Table or Schema

After you create grant authorizations and privileges to an Oracle Label Security policy, you can apply it to a database table or schema.

- [About Applying the Policy to a Database Table or Schema](#)
When you apply a policy to a table, the policy is automatically enabled.
- [Applying a Policy to a Schema](#)
The `SA_POLICY_ADMIN.APPLY_TABLE_POLICY` procedure applies a policy to either a table within a schema or an entire schema .

About Applying the Policy to a Database Table or Schema

When you apply a policy to a table, the policy is automatically enabled.

To disable a policy is to turn off its protections, although it is still applied to the table. To enable a policy is to turn on and enforce its protections for a particular table or schema.

To remove a policy is to take it entirely away from the table or schema. Note, however, that the policy label column and the labels remain in the table unless you explicitly drop them.

You can alter the default policy enforcement options for future tables that may be created in a schema. This does not, however, affect policy enforcement options on existing tables in the schema.

To change the enforcement options on an existing table, you must first *remove* the policy from the table, make the desired changes, and then reapply the policy to the table.

Be aware that you cannot enforce Oracle Label Security policies on external tables.

After you have created the policy components and configured user authorizations, privileges, and auditing for them, you can apply the policy to a database table or to an entire schema.

When you apply the policy to a database table, in addition to the policy name and target schema table, you must specify the following information:

- `table_options`: A comma-delimited list of policy enforcement options to be used for the table. If `NULL`, then the policy's default options are used.
- `label_function`: A string calling a function to return a label value to use as the default. For example, `my_label(:new.dept, :new.status)` computes the label based on the new values of the `DEPT` and `STATUS` columns in the row.
- `predicate`: An additional predicate to combine (using `AND` or `OR`) with the label-based predicate for `READ_CONTROL`

Note the following aspects of using Oracle Label Security policies with schemas:

- If you apply a policy to an empty schema, then every time you create a table within that schema, the policy is applied. Once the policy is applied to the schema, the default options you choose are applied to every table added.
- If you remove the policy from a table so that it is unprotected, and then run `SA_POLICY_ADMIN.ENABLE_SCHEMA_POLICY`, then the table will remain unprotected. If you wish to protect the table once again, then you must apply the policy to the table, or re-apply the policy to the schema.

If you apply a policy to a schema that already contains tables protected by the policy, then all future tables will have the new options that were specified when you applied the policy. The existing tables will retain the options they already had.

Applying a Policy to a Schema

The `SA_POLICY_ADMIN.APPLY_TABLE_POLICY` procedure applies a policy to either a table within a schema or an entire schema .

- Run `SA_POLICY_ADMIN.APPLY_TABLE_POLICY` to apply the policy to a schema, specifying the policy name, schema name, and necessary options.

The following example shows how to use the `SA_POLICY_ADMIN.APPLY_TABLE_POLICY` procedure to apply the `ols_admin_pol` policy to the `HR.EMPLOYEES` table.

```
BEGIN
SA_USER_ADMIN.APPLY_TABLE_POLICY (
  policy_name    => 'ols_admin_pol',
  schema_name    => 'hr',
  table_name     => 'employees',
  table_options  => 'READ_CONTROL,WRITE_CONTROL,CHECK_CONTROL',
  label_function => 'hr.gen_emp_label(:new.department_id,:new.salary',
  predicate      => NULL);
END;
/
```

This example shows how to use the `SA_POLICY_ADMIN.APPLY_SCHEMA_POLICY` procedure to apply a policy to an entire schema.

```
BEGIN
SA_USER_ADMIN.APPLY_SCHEMA_POLICY (
  policy_name    => 'ols_admin_pol',
  schema_name    => 'hr',
  default_options => NULL);
END;
/
```

Related Topics

- [SA_POLICY_ADMIN.APPLY_TABLE_POLICY](#)
The `SA_POLICY_ADMIN.APPLY_TABLE_POLICY` procedure adds the specified policy to a table.
- [SA_POLICY_ADMIN.APPLY_SCHEMA_POLICY](#)
The `SA_POLICY_ADMIN.APPLY_SCHEMA_POLICY` procedure applies a policy to all of the tables in a schema and enables the policy for these tables.

Step 6: Add Policy Labels to Table Rows

You must add policy labels to table rows.

- [About Adding Policy Labels to Table Rows](#)
After you have applied a policy to a table, you must add data labels to the rows in the table.
- [Adding a Policy Label to a Table Row](#)
You must update the table to which you are adding a policy label.

About Adding Policy Labels to Table Rows

After you have applied a policy to a table, you must add data labels to the rows in the table.

These labels are stored in the policy label column that you created earlier in the table. The user updating the table must have the `FULL` security privilege for the policy. This user is normally the owner of the table.

Adding a Policy Label to a Table Row

You must update the table to which you are adding a policy label.

1. To add data labels to a table, in SQL*Plus, enter an `UPDATE` statement using the following syntax:

```
UPDATE table_name
SET ols_column = CHAR_TO_LABEL('ols_policy','data_label')
WHERE UPPER(table_column) IN (column_data);
```

For example, suppose `LABCSYS` has created a policy called `ACCESS_LOCATIONS` and wants to add the label `SENS` to the cities Beijing, Tokyo, and Singapore in the `HR.LOCATIONS` table. The policy label column is called `ROW_LABEL`. The `UPDATE` statement is as follows:

```
UPDATE LOCATIONS
SET ROW_LABEL = CHAR_TO_LABEL('ACCESS_LOCATIONS','SENS')
WHERE UPPER(city) IN ('BEIJING', 'TOKYO', 'SINGAPORE');
```

2. Run the following `SELECT` statement to ensure that the policy was added to the table:

```
SELECT LABEL_TO_CHAR (ROW_LABEL) FROM LOCATIONS;
```

Step 7: (Optional) Configure Auditing

You can audit Oracle Label Security policies by using the `SA_USER_ADMIN` P/L SQL package.

- [About Configuring Auditing](#)
After you authorize users for the policy and grant them privileges, you can configure auditing for each user and for the policy itself.
- [Configuring Auditing](#)
The `SA_USER_ADMIN.AUDIT` procedure configures auditing for users in a non-unified auditing environment.

About Configuring Auditing

After you authorize users for the policy and grant them privileges, you can configure auditing for each user and for the policy itself.

If unified auditing is not enabled, then use the procedures in this section to configure the auditing. If it is enabled, then you must create a unified audit policy, as described in *Oracle Database Security Guide*.

[Table 5-10](#) describes the available auditing options.

Table 5-10 Auditing Options for Oracle Label Security

| Option | Description |
|------------|--|
| APPLY | Audits application of specified Oracle Label Security policies to tables and schemas |
| REMOVE | Audits removal of specified Oracle Label Security policies from tables and schemas |
| SET | Audits the setting of user authorizations, and user and program privileges |
| PRIVILEGES | Audits use of all policy-specific privileges |

Configuring Auditing

The `SA_USER_ADMIN.AUDIT` procedure configures auditing for users in a non-unified auditing environment.

- Run `SA_USER_ADMIN.AUDIT` to configure user auditing, specifying the policy name, one or more users, and the appropriate audit options.

For example:

```

BEGIN
  SA_USER_ADMIN.AUDIT(
    policy_name => 'ols_admin_pol',
    users       => 'hpreston',
    audit_option => 'REMOVE',
    audit_type  => 'BY ACCESS',
    success     => NULL);
END;
/

```

Related Topics

- [SA_AUDIT_ADMIN.AUDIT](#)
The `SA_AUDIT_ADMIN.AUDIT` procedure enables policy-specific auditing.

Using Enterprise Manager Cloud Control to Create an OLS Policy

You can create Oracle Label Security policies in Oracle Enterprise Manager Cloud Control.

- [Creating the Label Security Policy Container Using Cloud Control](#)
You can create the Oracle Label Security policy container in Cloud Control.
- [Creating Policy Components Using Cloud Control](#)
After you create a container for the policy and set enforcement options for it, you can create components for the policy.
- [Creating Data Labels for the Policy Using Cloud Control](#)
You can create data labels for an Oracle Label Security policy in Cloud Control.
- [Authorizing, Granting Privileges, and Auditing Users for a Policy Using Cloud Control](#)
You can authorize, grant privileges to, and set up auditing for users for a policy during the user creation process.
- [Granting Privileges to Trusted Program Units Using Cloud Control](#)
You can grant privileges to trusted program units in Cloud Control.
- [Applying a Policy to a Database Table with Cloud Control](#)
You can apply an Oracle Label Security policy to a database table in Cloud Control.
- [Applying Policy Labels to Table Rows Using Cloud Control](#)
You can apply Oracle Label Security policy labels to table rows in Cloud Control.
- [Auditing Oracle Label Security Policies Using Cloud Control](#)
You can audit Oracle Label Security policies in Cloud Control, except if you are using unified auditing.

Creating the Label Security Policy Container Using Cloud Control

You can create the Oracle Label Security policy container in Cloud Control.

1. Log in to Cloud Control as the `SYSTEM` user.
2. To navigate to your database, select **Databases** from the **Targets** menu.
3. Click the database name in the list that appears.
The database page appears.
4. Under the **Administration** menu, select **Security, Oracle Label Security**. The Label Security Policies page appears.
You may be required to log in to the database with appropriate credentials. You can use the `LBACSYS` account credentials that you create in [Enabling the LBACSYS Oracle Label Security Account](#).
5. Click **Create** to start creating a new label security policy. The Create Label Security Policy page appears.
6. Define the policy's name, label column, and the default policy enforcement options.
 - **Name:** Enter a name for the policy, for example, `ACCESS_LOCATIONS`.
 - **Label Column:** (Optional) Enter a name for the label column, for example, `OLS_COLUMN`. If you create an OLS policy without specifying the column name, the column name is auto-generated as `Pol_name_COL`. Later on, when you apply the policy to a table, the label column is added to that table. By default, the data type of the policy label column is `NUMBER(10)`. You can also specify an existing table column of the `NUMBER(10)` data type as the label column.

- **Hide Label Column:** Select to hide the column. When you first create the policy, you may want to disable **Hide Label Column** during the development phase of the policy. When the policy is satisfactory and ready for use by users, hide the column so that it is transparent to applications.
- **Enabled:** Toggle to enable or disable the policy.
- **Default Policy Enforcement Options:** The default policy enforcement options are used when the policy is applied. Ensure that these meet the needs of the application to which you are applying the policy.

Select from the following options:

- **Apply No Policy Enforcements (NO_CONTROL)**
- **Apply Policy Enforcements**
 - For all queries (READ_CONTROL)**
 - For Insert operations (INSERT_CONTROL)**
 - For Update Operations (UPDATE_CONTROL)**
 - Use session's default label for label column update (LABEL_DEFAULT)**
 - Operations that update the label column (LABEL_UPDATE)**
 - Update and Insert operations so that they are read accessible (CHECK_CONTROL)**

7. Click **OK**.

The new policy appears in the Oracle Label Security Policies page.

Creating Policy Components Using Cloud Control

After you create a container for the policy and set enforcement options for it, you can create components for the policy.

1. In the Oracle Label Security Policies page, select the policy you just created. Click **Edit**.
2. In the Edit Label Security Policy page, select the **Label Components** tab.
3. Click **Add 5 Rows** under Levels to add levels for the policy. Enter a Long Name, Short Name, and Numeric Tag for each level that you create. The numeric tag corresponds to the sensitivity of the level. To create more levels, you can click **Add 5 Rows** again. Use the same steps to create compartments and rows. For compartments and groups, the numeric tags do not correspond to sensitivity.

At a minimum, you must create one level, such as `SECRET`. Creating compartments and groups is optional.

The level numbers indicate the level of sensitivity for their corresponding labels. A greater number implies greater sensitivity. Select a numeric range that can be expanded later on, in case your security policy needs more levels. For example, if you have created levels `PUBLIC (7000)` and `SENSITIVE (8000)`, and you now want to create an intermediate level called `CONFIDENTIAL`, then you can assign the numeric value 7500 to this level.

Compartments identify categories associated with data, providing a finer level of granularity within a level. For example, a single table might have data

corresponding to different departments that you might like to separate using compartments. Compartments are optional.

Groups identify organizations owning or accessing the data. Groups are useful for the controlled dissemination of data and for timely reaction to organizational change. Groups are optional.

4. Click **Apply**.

Creating Data Labels for the Policy Using Cloud Control

You can create data labels for an Oracle Label Security policy in Cloud Control.

1. In the Label Security Policies page, select the policy that needs to have labels linked to levels.
2. In the **Actions** box, select Data Labels. Click **Go**.
The Data Labels page appears.
3. Click **Add**.
The Create Data Label page appears.
4. Enter the following information:
 - **Numeric Tag:** Enter a number that uniquely identifies the label. This number should be unique across all policies.
 - **Level:** Select a level from the list.
5. You can optionally select Compartments to add to the label. To add compartments, click **Add** under Compartments. Select the compartments to be added to the label. Click **Select** to add the compartments.
6. Optionally, to add groups, click **Add** under **Groups**. Select the groups to be added to the label. Click **Select** to add the groups.
7. Click **OK** in the Create Data Label page.
The data label appears in the Data Labels page.
8. Repeat steps 3 to 7 to create more data labels.

Alternatively, you can use the `SA_LABEL_ADMIN` package to define label components for a policy.



See Also:

[SA_LABEL_ADMIN Label Management PL/SQL Package](#)

Authorizing, Granting Privileges, and Auditing Users for a Policy Using Cloud Control

You can authorize, grant privileges to, and set up auditing for users for a policy during the user creation process.

1. In the Label Security Policies page, select the policy that needs authorization.

2. In the **Actions** box, select **Authorization**. Click **Go**.

The Create User page appears.

3. Add users as follows:

- Under Database Users, click **Add**. In the Search and Select window, select users that you want and then click **Select**.
- Under Non Database Users, click **Add 5 Rows**, and then add the user names of the non-database users that you want to add. Most application users are considered non-database users. A non-database user does not exist in the database. This can be any user name that meets the Oracle Database naming standards and can fit into the `VARCHAR2(30)` length field. However, be aware that Oracle Database does not automatically configure the associated security information for the non-database user when the application connects to the database. In this case, the application needs to call an Oracle Label Security function to assume the label authorizations of the specified user who is not a real database user.

4. In the Create User page, select the user that you want to authorize. Click **Next**. If you have multiple users that need the same authorizations, then select all users who need the same authorizations. Click **Next**.

The Privileges step appears.

5. Next, you can assign privileges to the user you selected in the preceding step. Privileges allow a database user to bypass certain controls enforced by the policy. Select the privileges you want to grant. Click **Next**.

If you do not want to assign any privileges to the user, then click **Next** without selecting any privileges.

The Labels, Compartments, and Groups step appears.

6. Next, to create the user label for the user: under Levels, use the flashlight icon to select data to enter for the following fields:

- **Maximum Level:** Enter the highest level for read and write access for this user.
- **Minimum Level:** Enter the lowest level for write access.
- **Default Level:** Enter the default level when the user logs in.

This value is equal to or greater than the minimum level and equal to or less than the maximum level.

- **Row Level:** Enter the level given to the row when user writes to the table.
7. Click **Add** under Compartments, to add compartments to the user label. Select the compartments to add. Click **Select**.
 8. For each compartment that you add, you can select the following properties:
 - **Write:** Allows the user to write to data that has the compartment as part of its label
 - **Default:** Adds the compartment to the user's default session label
 - **Row:** Adds the compartment to the data label when the user writes to the table
 9. Click **Add** under Groups, to add groups to the user label. Select the groups and click **Select**.

10. For each group that you add, you can select the following properties:

- **Write:** Allows the user to write to data that has the group as part of its label
 - **Default:** Adds the group to the user's default session label
 - **Row:** Adds the group to the data label when the user writes to the table
11. Click **Next**.
The Audit step appears.
 12. Select from the following audit options:
 - Policy Applied:
Audit On Success By audits successful application of the policy to a table or schema. Select `ACCESS` to audit by access or `SESSION` to audit by session.
Audit On Failure By audits failed application of the policy to a table or schema. Select `ACCESS` to audit by access or `SESSION` to audit by session.
 - Policy Removed:
Audit On Success By audits successful removal of the policy from a table or schema. Select `ACCESS` to audit by access or `SESSION` to audit by session.
Audit On Failure By audits failed removal of the policy from a table or schema. Select `ACCESS` to audit by access or `SESSION` to audit by session.
 - Labels And Privileges Set:
Audit On Success By audits successful setting of user authorizations and privileges. Select `ACCESS` to audit by access or `SESSION` to audit by session.
Audit On Failure By audits failed setting of user authorizations and privileges. Select `ACCESS` to audit by access or `SESSION` to audit by session.
 - All Policy Specific Privileges:
Audit On Success By audits successful use of policy privileges. Select `ACCESS` to audit by access or `SESSION` to audit by session.
Audit On Failure By audits failed use of policy privileges. Select `ACCESS` to audit by access or `SESSION` to audit by session.
 13. Click **Next**.
 14. You can review the policy authorization settings. Click **Finish** to create the policy authorization. Alternatively, you can click **Back** to modify the authorization settings.

Alternatively, you can use the `SA_USER_ADMIN` package to authorize users.

Granting Privileges to Trusted Program Units Using Cloud Control

You can grant privileges to trusted program units in Cloud Control.

1. In the Label Security Policies page, select the policy that needs authorization.
2. In the **Actions** box, select Authorization. Click **Go**.
The Authorization page appears.
3. Click the **Trusted Program Units** tab.
4. Click **Add** to add Oracle Label Security privileges for a procedure, function, or package.

The **Create Program Unit** page appears.

5. Enter the name of the procedure, function, or package, for which the privileges need to be granted, in the **Program Unit** field. You can also use the **Search** icon to search for the procedure, function, or package.
6. Select one or more policy-specific privileges that need to be granted to the program unit. Click **OK**.

The trusted program unit is added to the Authorizations page.

Alternatively, you can use the **SA_USER_ADMIN** package to authorize trusted program units.

Related Topics

- [Administering and Using Trusted Stored Program Units](#)
You can use trusted stored program units to enhance system security.

Applying a Policy to a Database Table with Cloud Control

You can apply an Oracle Label Security policy to a database table in Cloud Control.

1. In the Label Security Policies page, select the policy that needs to be applied to a table.
2. Select Apply from the **Actions** box. Click **Go**.

The Apply page appears.

3. Select the **Tables** tab to apply the policy to a table.

Select the **Schemas** tab if you are applying the policy to a schema. The process is same as applying the policy to a table.

4. Click **Create**.

The Add Table page appears.

5. Next to the **Table** box, click the flashlight icon.

6. In the Search and Select window, enter the following information under Search:

- **Schema:** Enter the name of the schema in which the table appears. Leaving this field empty displays tables in all schemas.
- **Name:** Optionally, enter the name of the table. Leaving this box empty displays all the tables within the schema.

To narrow the search by using wildcards, use the percent (%) sign. For example, enter o% to search for all tables beginning with the letter O.

7. Select the table and click **Select**.

The Add Table page appears.

8. Enter the following information:

- **Policy Enforcement Options:** Select enforcement options as needed. These options will apply to the table on top of the enforcement options that you selected when you created the policy in [Step 1: Create the Label Security Policy Container](#).

To make no change from those enforcement options, that is, to use the same enforcement options created earlier, select **Use Default Policy Enforcement**. To add more enforcement options, select from the other options listed.

- **Labeling Function:** Optionally, specify a labeling function to automatically compute the label to be associated with a new or updated row. That function is always invoked thereafter to provide the data labels written under that policy, because active labeling functions take precedence over any alternative means of supplying a label.
 - **Predicate:** Optionally, specify an additional predicate to combine (using **AND** or **OR**) with the label-based predicate for `READ_CONTROL`.
9. Click **OK**.

Applying Policy Labels to Table Rows Using Cloud Control

You can apply Oracle Label Security policy labels to table rows in Cloud Control.

1. In the Label Security Policies page, select the policy, for example, `ACCESS_LOCATIONS`.
2. Select Authorization from the **Actions** box. Click **Go**.
The Authorization page appears.
3. Click **Add**.
The Create User page appears.
4. Under Database Users, click **Add**.
The Search and Select window appears.
5. Select the check box corresponding to the user that owns the table. Click **Select**.
The Create User page lists the user that was added.
6. Click **Next**.
The Privileges step appears.
7. Select the appropriate privileges for the user, and then click **Next**.
The Labels, Compartments, and Groups page appears.
8. Click **Next**.
The Audit step appears.
9. Click **Next**.
The Review step appears.
10. Click **Finish**.

Auditing Oracle Label Security Policies Using Cloud Control

You can audit Oracle Label Security policies in Cloud Control, except if you are using unified auditing.

1. In the Label Security Policies page, select the policy that you need to configure.
2. Click **Edit**.
The Edit Label Security Policy Settings page appears.
3. Click the **Advanced** tab. You can edit the audit settings under the Audit section.

4. Select **Include Label In Audit trail** under Audit Labels, if you wish to include user session labels in the audit table.
5. Select the **Operation**, to audit, under Audit Settings. You can choose from the following operations:
 - Policy Applied: Audits application of the policy to a table or schema.
 - Policy Removed: Audits removal of the policy from a table or schema.
 - Labels And Privileges Set: Audits setting of user authorizations and privileges.
 - All Policy Specific Privileges: Audits use of policy privileges.
6. Click **Add** under Policy Applied to add users that will be audited for the **Operation** you selected in the preceding step.

The Search and Select window appears.
7. Select the users that you need to add. Click **Select**.
8. Select values for **Audit on Success By** and **Audit on Failure By**, for each user that you added.

For each user that you added, you can choose to audit successful and failed instances of the chosen operation. You can also choose to audit by access or session.
9. Repeat steps 5 to 8 for each operation that you choose to audit.

Related Topics

- [Auditing Under Oracle Label Security](#)

You can use Oracle Label Security auditing if you have not configured your database to use unified auditing.

6

Working with Labeled Data

You can manage labeled data, view that data of security attributes for a session, and change the value of session attributes.

Note:

Many of the examples in this guide use the `HUMAN_RESOURCES` sample policy. Its policy name is `HR` and its policy label column is `HR_LABEL`. Unless otherwise noted, the examples assume that the SQL statements are performed on rows within the user's authorization and with full Oracle Label Security policy enforcement in effect.

- [How Policy Label Column and Label Tags Work](#)
You should understand how policy label columns in a table or schema are created and filled.
- [Assignments of Labels to Data Rows](#)
For existing data rows, labels can be assigned by a labeling function that you create.
- [Presenting the Label](#)
When you retrieve labels, you do not automatically obtain the character string value.
- [Filtration of Data Using Labels](#)
When SQL statements are processed, Oracle Label Security makes calls to the security policies defined in the database by create-and-apply procedures.
- [Inserting Labeled Data](#)
You can insert labeled data in a variety of situations.
- [Changing Session and Row Labels](#)
During a session, a user can change labels based on the authorizations an administrator sets.

How Policy Label Column and Label Tags Work

You should understand how policy label columns in a table or schema are created and filled.

- [The Policy Label Column](#)
You should understand how to use policy label columns.
- [Label Tags](#)
You can create label tags, either manually or automatically generating them, that define the label components.

The Policy Label Column

You should understand how to use policy label columns.

- [About the Policy Label Column](#)
Each policy that is applied to a table creates a column in the database.
- [Hiding the Policy Label Column](#)
You can choose not to display the column representing a policy.

About the Policy Label Column

Each policy that is applied to a table creates a column in the database.

By default, the data type of the `NUMBER`.

Each row's label for that policy is represented by a tag in that column, using the numeric equivalent of the character-string label value. The label tag is automatically generated when the label is created, unless the administrator specifies the tag manually at that time.

The automatic label generation follows the rules established by the administrator while defining the label components, as described in [Understanding Data Labels and User Labels](#).



Note:

The act of creating a policy does not in itself have any effect on tables or schemas. It only applies the policy to a table or schema.

Hiding the Policy Label Column

You can choose not to display the column representing a policy.

- To hide the display of a column, apply the `HIDE` option to the table.

After a policy using `HIDE` is applied to a table, a user executing a `SELECT *` or performing a `DESCRIBE` operation will not see the policy label column. If the policy label column is not hidden, then the label tag is displayed as data type `NUMBER`.

Example 1: Numeric Column Data Type (NUMBER)

```
DESCRIBE EMP;
Name                               Null?    Type
-----
EMPNO                               NOT NULL NUMBER(4)
ENAME                               CHAR(10)
JOB                                  CHAR(9)
MGR                                  NUMBER(4)
SAL                                  NUMBER(7,2)
DEPTNO                              NOT NULL NUMBER(2)
HR_LABEL                             NUMBER(10)
```

Example 2: Numeric Column Data Type with Hidden Column

Notice that in this example, the `HR_LABEL` column is *not* displayed.

```
DESCRIBE EMP;
Name                               Null?    Type
-----
EMPNO                               NOT NULL NUMBER(4)
ENAME                               CHAR(10)
JOB                                  CHAR(9)
MGR                                  NUMBER(4)
SAL                                  NUMBER(7,2)
DEPTNO                              NOT NULL NUMBER(2)
```

Related Topics

- [How the HIDE Policy Column Option Works](#)
You can specify the `HIDE` policy configuration option when you add an Oracle Label Security policy column to a table.

Label Tags

You can create label tags, either manually or automatically generating them, that define the label components.

- [About Label Tags](#)
The administrator first defines a set of label components to be used in a policy.
- [Manually Defined Label Tags to Order Labels](#)
By manually defining label tags, you can implement a data manipulation strategy that permits labels to be meaningfully sorted and compared.
- [Manually Defined Label Tags to Manipulate Data](#)
An administratively defined label tag is a convenient way to reference a complete label string (that is, a combination of label components).
- [Automatically Generated Label Tags](#)
Dynamically generated label tags have 10 digits, with no relationship to numbers assigned to any label component.

About Label Tags

The administrator first defines a set of label components to be used in a policy.

When creating labels, the administrator specifies the set of valid combinations of components that can make up a label, that is, a level optionally combined with one or more groups or compartments.

Each such valid label within a policy is uniquely identified by an associated numeric tag assigned by the administrator or generated automatically upon its first use. Manual definition has the advantage of allowing the administrator to control the ordering of label values when they are sorted or logically compared.

However, label tags must be unique across all policies in the database. When you use multiple policies in a database, you cannot use the same numeric label tag in different policies. Remember that each label tag uniquely identifies one label, and that numeric tag is what is stored in the data rows, not the label's character-string representation.

Manually Defined Label Tags to Order Labels

By manually defining label tags, you can implement a data manipulation strategy that permits labels to be meaningfully sorted and compared.

To do this, you must predefine all of the labels to be associated with protected data, and assigns to each label a meaningful label tag value. Manually assigned label tags can have up to eight digits. The value of a label tag must be greater than zero.

It may be advantageous to implement a strategy in which label tag values are related to the numeric values of label components. In this way, you can use the tags to group data rows in a meaningful way. This approach, however, is not mandatory. It is good practice to set tags for labels of higher sensitivity to a higher numeric value than tags for labels of lower sensitivity.

[Table 6-1](#) illustrates a set of label tags that have been assigned. Notice that, in this example, the administrator has based the label tag value on the numeric form of the levels, compartments, and rows that were discussed in [Understanding Data Labels and User Labels](#).

Table 6-1 Administratively Defined Label Tags (Example)

| Label Tag | Label String |
|-----------|--------------|
| 10000 | P |
| 20000 | C |
| 21000 | C:FNCL |
| 21100 | C:FNCL,OP |
| 30000 | S |
| 31110 | S:OP:WR |
| 40000 | HS |
| 42000 | HS:OP |

In this example, labels with a level of `PUBLIC` begin with "1", labels with a level of `CONFIDENTIAL` begin with "2", labels with a level of `SENSITIVE` begin with "3", and labels with a level of `HIGHLY_SENSITIVE` begin with "4".

Labels with the `FINANCIAL` compartment then come in the 1000 range, labels with the compartment `OP` are in the 1100 range, and so on. The tens place is used to indicate the group `WR`, for example.

Another strategy might be completely based on groups, where the tags might be 3110, 3120, 3130, and so on.

Note, however, that label tags identify the *whole* label, independent of the numeric values assigned for the individual label components. The label tag is used as a whole integer, not as a set of individually evaluated numbers.

Manually Defined Label Tags to Manipulate Data

An administratively defined label tag is a convenient way to reference a complete label string (that is, a combination of label components).

As illustrated in [Table 6-1](#), for example, the tag "31110" could stand for the complete label string "S:OP:WR".

Label tags can be used as a convenient way to partition data. For example, all data with labels in the range 1000 - 1999 could be placed in tablespace A, all data with labels in the range 2000 - 2999 could be placed in tablespace B, and so on.

This simplified notation also comes in handy when there is a finite number of labels and you need to perform various operations upon them. Consider a situation in which one company hosts a human resources system for many other companies. Assume that all users from Company Y have the label "C:ALPHA:CY", for which the tag "210" has been set. To determine the total number of application users from Company Y, the host administrator can enter:

```
SELECT * FROM tabl
WHERE hr_label = 210;
```

Automatically Generated Label Tags

Dynamically generated label tags have 10 digits, with no relationship to numbers assigned to any label component.

You cannot group the data by label.

[Table 6-2](#) describes how automatically generated label tags work.

Table 6-2 Generated Label Tags (Example)

| Label Tag | Label String |
|-----------|--------------|
| 100000020 | P |
| 100000052 | C |
| 100000503 | C:FNCL |
| 100000132 | C:FNCL,OP |
| 100000003 | S |
| 100000780 | S:OP:WR |
| 100000035 | HS |
| 100000036 | HS:OP |

Assignments of Labels to Data Rows

For existing data rows, labels can be assigned by a labeling function that you create.

In such a function, you specify the exact table and row conditions defining what label to insert. The function can be named in the call to apply a policy to a table or schema, or in an update by the administrator.

Related Topics

- [Inserting Labeled Data](#)
You can insert labeled data in a variety of situations.
- [Labeling Functions](#)
Labeling functions can compute and return a label using resources such as context variables (for example, date or username) and data values.

- [SA_POLICY_ADMIN.APPLY_TABLE_POLICY](#)
The `SA_POLICY_ADMIN.APPLY_TABLE_POLICY` procedure adds the specified policy to a table.
- [SA_POLICY_ADMIN.APPLY_SCHEMA_POLICY](#)
The `SA_POLICY_ADMIN.APPLY_SCHEMA_POLICY` procedure applies a policy to all of the tables in a schema and enables the policy for these tables.

Presenting the Label

When you retrieve labels, you do not automatically obtain the character string value.

By default, the label tag value is returned. Two label manipulation functions enable you to convert the label tag value to and from its character string representation.

- [Converting a Character String to a Label Tag with CHAR_TO_LABEL](#)
The `CHAR_TO_LABEL` function converts character strings to a label tag, returning the label tag for the specified character string.
- [Conversion of a Label Tag to a Character String, with LABEL_TO_CHAR](#)
You can convert label tags to character strings.

Converting a Character String to a Label Tag with CHAR_TO_LABEL

The `CHAR_TO_LABEL` function converts character strings to a label tag, returning the label tag for the specified character string.

- To convert a character string to a label tag, use the following syntax for the `CHAR_TO_LABEL` function:

```
FUNCTION CHAR_TO_LABEL (  
    policy_name    IN VARCHAR2,  
    label_string   IN VARCHAR2)  
RETURN NUMBER;
```

For example:

```
INSERT INTO emp (empno,hr_label)  
VALUES (999, CHAR_TO_LABEL('HR','S:A,B:G5'));
```

Here, `HR` is the label policy name, `s` is a sensitivity level, `A,B` compartments, and `G5` a group.

```
FUNCTION CHAR_TO_LABEL (  
    policy_name    IN VARCHAR2,  
    label_string   IN VARCHAR2)  
RETURN NUMBER;
```

Here, `HR` is the label policy name, `s` is a sensitivity level, `A,B` compartments, and `G5` a group.

Conversion of a Label Tag to a Character String, with LABEL_TO_CHAR

You can convert label tags to character strings.

- [Converting a Label Tag to a Character String with LABEL_TO_CHAR](#)
The `LABEL_TO_CHAR` function returns a `VARCHAR2` string when it converts a label tag to a character string.
- [LABEL_TO_CHAR Examples](#)
Oracle provides examples that illustrate the use of `LABEL_TO_CHAR`.
- [Retrieving All Columns from a Table When the Policy Label Column Is Hidden](#)
If the policy label column is hidden, then it is not automatically returned when you execute `SELECT *` on the table.

Converting a Label Tag to a Character String with LABEL_TO_CHAR

The `LABEL_TO_CHAR` function returns a `VARCHAR2` string when it converts a label tag to a character string.

When you query a table or view, you automatically retrieve all of the rows in the table or view that satisfy the qualifications of the query and are dominated by your label. If the policy label column is not hidden, then the label tag value for each row is displayed. You must use the `LABEL_TO_CHAR` function to display the character string value of each label.

Note that all conversions must be explicit. There is no automatic casting to and from tag and character string representations.

- To convert a label tag to a character string, use the following syntax for the `LABEL_TO_CHAR` function:

```
FUNCTION LABEL_TO_CHAR (
    label IN NUMBER)
RETURN VARCHAR2;
```

LABEL_TO_CHAR Examples

Oracle provides examples that illustrate the use of `LABEL_TO_CHAR`.

Example: Retrieving a Row Label from a Table or a View

To retrieve the label of a row from a table or view, specify the policy label column in the `SELECT` statement.

For example:

```
SELECT label_to_char (hr_label) AS label, ename FROM tab1;
WHERE ename = 'RWRIGHT';
```

This statement returns the following:

```
LABEL          ENAME
-----
S:A,B:G1      RWRIGHT
```

Example: Retrieving a Policy Label Column

You can also specify the policy label column in the `WHERE` clause of a `SELECT` statement.

The following statement displays all rows that have the policy label `S:A,B:G1`

```
SELECT label_to_char (hr_label) AS label,ename FROM emp
WHERE hr_label = char_to_label ('HR', 'S:A,B:G1');
```

This statement returns the following:

```
LABEL          ENAME
-----
S:A,B:G1      RWRIGHT
S:A,B:G1      ESTANTON
```

Alternatively, you could use a more flexible statement to look up data that contains the string "S:A,B:G1" anywhere in the text of the `HR_LABEL` column:

```
SELECT label_to_char (hr_label) AS label,ename FROM emp
WHERE label_to_char (hr_label) like '%S:A,B:G1%';
```

If you do not use the `LABEL_TO_CHAR` function, then you will see the label tag.

Example: Retrieving a Numeric Column Data Type

The following example is with the numeric column data type (`NUMBER`) and dynamically generated label tags, but without using the `LABEL_TO_CHAR` function. If you do not use the `LABEL_TO_CHAR` function, then you will see the label tag.

```
SQL> select empno, hr_label from emp
      where ename='RWRIGHT';
```

```
EMPNO      HR_LABEL
-----
7839      1000000562
```

Retrieving All Columns from a Table When the Policy Label Column Is Hidden

If the policy label column is hidden, then it is not automatically returned when you execute `SELECT *` on the table.

- To explicitly specify that you want to retrieve a label, use the `LABEL_TO_CHAR` function in the `SELECT` statement.

For example, to retrieve all columns from the `DEPT` table (including the policy label column in its character representation), enter the following:

```
COLUMN LABEL FORMAT a10
SELECT LABEL_TO_CHAR (hr_label) AS LABEL, DEPT.* FROM DEPT;
```

Running these SQL statements returns the following data:

Table 6-3 Data Returned from Sample SQL Statements re Hidden Column

| LABEL | DEPTNO | DNAME | LOC |
|-------|--------|------------|----------|
| L1 | 10 | ACCOUNTING | NEW YORK |
| L1 | 20 | RESEARCH | DALLAS |
| L1 | 30 | SALES | CHICAGO |
| L1 | 40 | OPERATIONS | BOSTON |

By contrast, if you do not explicitly specify the `HR_LABEL` column, the label is not displayed at all. Note that while the policy column name is on a policy basis, the `HIDE` option is on a table-by-table basis.

Related Topics

- [How the HIDE Policy Column Option Works](#)
You can specify the `HIDE` policy configuration option when you add an Oracle Label Security policy column to a table.

Filtration of Data Using Labels

When SQL statements are processed, Oracle Label Security makes calls to the security policies defined in the database by create-and-apply procedures.

For `SELECT` statements, the policy filters the data rows that the user is authorized to see. For `INSERT`, `UPDATE`, and `DELETE` statements, Oracle Label Security permits or denies the requested operation, based on the user's authorizations.

- [Use of Numeric Label Tags in WHERE Clauses](#)
There are different techniques of using numeric label tags in `WHERE` clauses of `SELECT` statements.
- [Ordering Labeled Data Rows](#)
The `ORDER BY` clause of a `SELECT` statement can be used to order rows by the numeric label tag.
- [Ordering by Character Representation of Label](#)
The `LABEL_TO_CHAR` function orders data rows by the character representation of the label.
- [Determination of the Upper and Lower Bounds of Labels](#)
Oracle Label Security provides functions that determine the least upper bound or the greatest lower bound of two or more labels.
- [Merging Labels with the MERGE_LABEL Function](#)
The `MERGE_LABEL` function merges two labels together.

Use of Numeric Label Tags in WHERE Clauses

There are different techniques of using numeric label tags in `WHERE` clauses of `SELECT` statements.

When using labels in the `NUMBER` format, you can set up labels so that a list of your label tags distinguishes the different levels. Comparisons of these numeric label tags can be used for `ORDER BY` processing, and with the logical operators.

For example, if you have assigned all `UNCLASSIFIED` labels to the 1000 range, all `SENSITIVE` labels to the 2000 range, and all `HIGHLY_SENSITIVE` labels to the 3000 range, then you can list all `SENSITIVE` records.

```
SELECT * FROM emp
WHERE hr_label BETWEEN 2000 AND 2999;
```

To list all `SENSITIVE` and `UNCLASSIFIED` records, you can enter:

```
SELECT * FROM emp
WHERE hr_label <3000;
```

To list all `HIGHLY_SENSITIVE` records, you can enter:

```
SELECT * FROM emp
WHERE hr_label=3000;
```

 **Note:**

Remember that such queries have meaning only if the administrator has applied a numeric ordering strategy to the label tags that he or she originally assigned to the labels. In this way, the administrator can provide for convenient dissemination of data. If, however, the label tag values are generated automatically, then there is no intrinsic relationship between the value of the tag and the order of the labels.

Alternatively, you can use dominance relationships to set up an ordering strategy.

Related Topics

- [Using Dominance Functions](#)
Oracle Label Security provides functions to control dominance.

Ordering Labeled Data Rows

The `ORDER BY` clause of a `SELECT` statement can be used to order rows by the numeric label tag.

- To perform the `ORDER BY` operation, use a `SELECT` statement similar to the following:

```
SELECT * from emp
ORDER BY hr_label;
```

Notice that no functions were necessary in this statement. The statement made use of label tags set up by the administrator.

 **Note:**

Again, such queries have meaning only if the administrator has applied a numeric ordering strategy to the label tags originally assigned to the labels.

Ordering by Character Representation of Label

The `LABEL_TO_CHAR` function orders data rows by the character representation of the label.

- To order data rows by the character representation of a label, use a statement similar to the following, which returns all rows sorted by the text order of the label :

```
SELECT * FROM emp
ORDER BY label_to_char (hr_label);
```

Determination of the Upper and Lower Bounds of Labels

Oracle Label Security provides functions that determine the least upper bound or the greatest lower bound of two or more labels.

Two single-row functions operate on each row returned by a query. They return one result for each row.

 **Note:**

In all functions that take multiple labels, the labels must all belong to the same policy.

- **Finding Least Upper Bound with LEAST_UBOUND**
The `OLS_LEAST_UBOUND` (`OLS_LUBD`) function returns a character string label that is the least upper bound of `label1` and `label2`.
- **Finding Greatest Lower Bound with GREATEST_LBOUND**
The `OLS_GREATEST_LBOUND` (`OLS_GLBD`) standalone function determines the lowest label of the data that can be involved in an operation, given two different labels.

Finding Least Upper Bound with LEAST_UBOUND

The `OLS_LEAST_UBOUND` (`OLS_LUBD`) function returns a character string label that is the least upper bound of `label1` and `label2`.

That is, the one label that dominates both. The least upper bound is the highest level, the union of the compartments in the labels, and the union of the groups in the labels.

For example, the least upper bound of `HIGHLY_SENSITIVE:ALPHA` and `SENSITIVE:BETA` is `HIGHLY_SENSITIVE:ALPHA,BETA`.

- To find the least upper bound, use the following syntax:

```
FUNCTION OLS_LEAST_UBOUND (
    label1                IN NUMBER,
    label2                IN NUMBER)
RETURN VARCHAR2;
```

The `OLS_LEAST_UBOUND` function is useful when joining rows with different labels, because it provides a high water mark label for joined rows.

The following query compares each employee's label with the label of his or her department, and returns the higher label, whether it be in the `EMP` table or the `DEPT` table.

```
SELECT ename,dept.deptno,
       OLS_LEAST_UBOUND(emp.hr_label,dept.hr_label) as label
FROM emp, dept
WHERE emp.deptno=dept.deptno;
```

This query returns the following data:

Table 6-4 Data Returned from Sample SQL Statements re Least_UBound

| ENAME | DEPTNO | LABEL |
|--------|--------|----------|
| KING | 10 | L3:M:D10 |
| BLAKE | 30 | L3:M:D30 |
| CLARK | 10 | L3:M:D10 |
| JONES | 20 | L3:M:D20 |
| MARTIN | 30 | L2:E:D30 |

 **Note:**

The old OLS functions, `LEAST_UBOUND` and `LUBD` have been deprecated in Oracle Database 12c release 1 (12.1).

You can still use the old functions in this release, but Oracle recommends that you use the `OLS_LEAST_UBOUND` and `OLS_LUBD` functions instead. Using the new function names avoids potential name conflicts with other database components.

Finding Greatest Lower Bound with `GREATEST_LBOUND`

The `OLS_GREATEST_LBOUND` (`OLS_GLBD`) standalone function determines the lowest label of the data that can be involved in an operation, given two different labels.

This function returns a character string label that is the greatest lower bound of `label1` and `label2`. The greatest lower bound is the lowest level, the intersection of the compartments in the labels and the groups in the labels. For example, the greatest lower bound of `HIGHLY_SENSITIVE:ALPHA` and `SENSITIVE` is `SENSITIVE`.

- To find the greatest lower bound, use the following syntax:

```
FUNCTION OLS_GREATEST_LBOUND (  
    label1          IN NUMBER,  
    label2          IN NUMBER)  
RETURN VARCHAR2;
```

 **Note:**

The old OLS functions, `GREATEST_LBOUND` and `GLBD` were deprecated in Oracle Database 12c release 1 (12.1).

You can still use the old functions in this release, but Oracle recommends that you use the `OLS_GREATEST_LBOUND` and `OLS_GLBD` functions instead. Using the new function names avoids potential name conflicts with other database components.

Merging Labels with the `MERGE_LABEL` Function

The `MERGE_LABEL` function merges two labels together.

It accepts the character string form of two labels and the three-character specification of a merge format.

- To merge labels, use the following syntax:

```
FUNCTION merge_label (label1 IN number,  
                    label2 IN number,  
                    merge_format IN VARCHAR2)  
RETURN number;
```

The valid merge format is specified with a three-character string:

<highest level or lowest level><union or intersection of compartments><union or intersection of groups>

- The first character indicates whether to merge using the highest level or the lowest level of the two labels.
- The second character indicates whether to merge using the union or the intersection of the compartments in the two labels.
- The third character indicates whether to merge using the union or the intersection of the groups in the two labels.

Table 6-5 defines the `MERGE_LABEL` format constants.

Table 6-5 MERGE_LABEL Format Constants

| Format Specification | Data Type | Constant | Meaning | Positions in Which Format Is Used |
|--------------------------|-------------------------|----------|---|--|
| <code>max_lvl_fmt</code> | CONSTANT varchar2(1) | H | Maximum level | First (level) |
| <code>min_lvl_fmt</code> | CONSTANT varchar2(1) | L | Minimum level | First (Level) |
| <code>union_fmt</code> | CONSTANT varchar2(1) | U | Union of the two labels | Second (compartments) and Third (groups) |
| <code>inter_fmt</code> | CONSTANT varchar2(1) | I | Intersection of the two labels | Second (compartments) and Third (groups) |
| <code>minus_fmt</code> | CONSTANT varchar2(1) | M | Remove second label from first label | Second (compartments) and Third (groups) |
| <code>null_fmt</code> | CONSTANT varchar2(1) | N | If specified in compartments column, returns no compartments. If specified in groups column, returns no groups. | Second (compartments) and Third (groups) |

For example, `HUI` specifies the highest level of the two labels, union of the compartments, intersection of the groups.

The `MERGE_LABEL` function is particularly useful to developers if the `LEAST_UBOUND` function does not provide the intended result. The `LEAST_UBOUND` function, when used with two labels containing groups, may result in a less sensitive data label than expected. The `MERGE_LABEL` function enables you to compute an intersection on the groups, instead of the union of groups that is provided by the `LEAST_UBOUND` function.

For example, if the label of one data record contains the group `UNITED_STATES`, and the label of another data record contains the group `UNITED_KINGDOM`, and the `LEAST_UBOUND` function is used to compute the least upper bound of these two labels, then the

resulting label would be accessible to users authorized for either the `UNITED_STATES` or the `UNITED_KINGDOM`.

If, by contrast, the `MERGE_LABEL` function is used with a format clause of `HUI`, then the resulting label would contain the highest level, the union of the compartments, and no groups. This is because `UNITED_STATES` and `UNITED_KINGDOM` do not intersect.

Inserting Labeled Data

You can insert labeled data in a variety of situations.

- [About Inserting Labeled Data](#)
When you insert data into a table protected by an Oracle Label Security policy, you must supply a numeric label value tag.
- [Inserting Labels Using `CHAR_TO_LABEL`](#)
To insert a row label, you can specify the label character string and then transform it into a label using the `CHAR_TO_LABEL` function.
- [Inserting Labels Using Numeric Label Tag Values](#)
You can insert data using the numeric label tag value of a label, rather than using the `CHAR_TO_LABEL` function.
- [Inserting Data Without Specifying a Label](#)
There are two situations in which you do not need to specify a label in `INSERT` statements.
- [Inserting Data When the Policy Label Column Is Hidden](#)
If the label column is hidden, then the existence of the column is transparent to the insertion of data.
- [Inserting Labels Using `TO_DATA_LABEL`](#)
The `TO_DATA_LABEL` function can generate new labels dynamically.

About Inserting Labeled Data

When you insert data into a table protected by an Oracle Label Security policy, you must supply a numeric label value tag.

Usually, you can insert this value in the `INSERT` statement itself.

To do this, you must explicitly specify the tag for the desired label or explicitly convert the character string representation of the label into the correct tag. Note that this does not mean generating new label tags, but referencing the correct tag. When Oracle Label Security is using Oracle Internet Directory, the only permissible labels (and corresponding tags) are those pre-defined by the administrator and already in Oracle Internet Directory.

The only times an `INSERT` statement may omit a label value are:

- If the `LABEL_DEFAULT` enforcement option was specified when the policy was applied, or
- If no enforcement options were specified when the policy was applied and `LABEL_DEFAULT` was specified when the policy was created
- If the statement applying the policy named a labeling function.

In the first two cases, the user's session default row label is used as the inserted row's label. In the third case, the inserted row's label is created by that labeling function.

Related Topics

- [Labeling Functions](#)
Labeling functions can compute and return a label using resources such as context variables (for example, date or username) and data values.
- [Implementing Policy Enforcement Options and Labeling Functions](#)
You can customize the enforcement of Oracle Label Security policies and implement labeling functions.

Inserting Labels Using CHAR_TO_LABEL

To insert a row label, you can specify the label character string and then transform it into a label using the `CHAR_TO_LABEL` function.

The `CHAR_TO_LABEL` function automatically creates a valid data label.

- To insert labels, use an `INSERT INTO` statement.

Using the definition for table `emp`, the following example shows how to insert data with explicit labels:

```
INSERT INTO emp (ename, empno, hr_label)
VALUES ('ESTANTON', 10, char_to_label ('HR', 'SENSITIVE'));
```

Inserting Labels Using Numeric Label Tag Values

You can insert data using the numeric label tag value of a label, rather than using the `CHAR_TO_LABEL` function.

- To insert labels using numeric label tag values, use an `INSERT INTO` statement.

For example, if the numeric label tag for `SENSITIVE` is 3000, it would appear as follows:

```
INSERT INTO emp (ename, empno, hr_label)
VALUES ('ESTANTON', 10, 3000);
```

Inserting Data Without Specifying a Label

There are two situations in which you do not need to specify a label in `INSERT` statements.

If `LABEL_DEFAULT` is set, or if there is a labeling function applied to the table, then you do not need to specify a label in your `INSERT` statements. The label will be provided automatically.

- To insert data without specifying a label, use an `INSERT INTO` statement.

For example:

```
INSERT INTO emp (ename, empno)
VALUES ('ESTANTON', 10);
```

The resulting row label is set according to the default value (or by a labeling function).

Inserting Data When the Policy Label Column Is Hidden

If the label column is hidden, then the existence of the column is transparent to the insertion of data.

`INSERT` statements can be written that do not explicitly list the table columns and do not include a value for the label column.

The session's row label is used to label the data, or a labeling function is used if one was specified when the policy was applied to the table or schema.

You can insert into a table without explicitly naming the columns, as long as you specify a value for each non-hidden column in the table. The following example shows how to insert a row into the table described in [Example 2: Numeric Column Data Type with Hidden Column](#):

- To insert data when the policy label column is hidden, use the following syntax:

```
INSERT INTO emp
VALUES ('196', 'ESTANTON', Technician, RSTOUT, 50000, 10);
```

Its label will be one of the following three possibilities:

- The label you specify
- The label established by the `LABEL_DEFAULT` option of the policy being applied
- The label created by a labeling function named by the policy being applied

Note:

If the policy label column is *not* hidden, then you must explicitly include a label value (possibly null, indicated by a comma) in the `INSERT` statement.

Inserting Labels Using `TO_DATA_LABEL`

The `TO_DATA_LABEL` function can generate new labels dynamically.

This approach guarantees that the data labels are valid. However, be aware that when Oracle Label Security is installed to work with Oracle Internet Directory, dynamic label generation is not allowed, because labels are managed centrally in Oracle Internet Directory, using `olsadmintool` commands. Therefore, when Oracle Label Security is directory-enabled, this function, `TO_DATA_LABEL`, is not available and will generate an error message if used.

1. Ensure that you have the `EXECUTE` privilege on the `TO_DATA_LABEL` function.
2. Use the `TO_DATA_LABEL` as necessary, for example, in an `INSERT INTO` statement.

For example:

```
INSERT INTO emp (ename, empno, hr_label)
VALUES ('ESTANTON', 10, to_data_label ('HR', 'SENSITIVE'));
```

 **Note:**

The `TO_DATA_LABEL` function must be explicitly granted to individuals, in order to be used. Its usage should be tightly controlled.

Related Topics

- [Command-line Tools for Label Security Using Oracle Internet Directory](#)
Oracle Label Security provides command-line tools for using Oracle Internet Directory.

Changing Session and Row Labels

During a session, a user can change labels based on the authorizations an administrator sets.

Related Topics

- [SA_SESSION Session Management PL/SQL Package](#)
The `SA_SESSION` PL/SQL package manages session behavior for user authorizations.

7

Oracle Label Security Using Oracle Internet Directory

You can use Oracle Label Security with Oracle Internet Directory.

- [About Label Management on Oracle Internet Directory](#)
Managing Oracle Label Security metadata in a centralized LDAP repository provides many benefits.
- [Configuring Oracle Internet Directory-Enabled Label Security](#)
You can configure Oracle Internet Directory-enabled Oracle Label Security.
- [Oracle Label Security Profiles](#)
A user profile is a set of user authorizations and privileges.
- [Integrated Capabilities When Label Security Uses the Directory](#)
The integration of Oracle Label Security and Oracle Internet Directory enables the several capabilities.
- [Oracle Label Security Policy Attributes in Oracle Internet Directory](#)
In Oracle Internet Directory, Oracle-related metadata is stored under `cn=OracleContext`.
- [Subscription of Policies in Directory-Enabled Label Security](#)
In an Oracle Internet Directory-enabled Oracle Label Security, you must subscribe a policy before it can be applied (by `SA_POLICY_ADMIN.APPLY_TABLE_POLICY` or `SA_POLICY_ADMIN.APPLY_SCHEMA_POLICY`).
- [Restrictions on New Data Label Creation](#)
When Oracle Label Security is used with Oracle Internet Directory, data labels must be pre-defined in the directory.
- [Administrator Duties for Oracle Internet Directory and Oracle Label Security](#)
Administrators listed within a policy are those individuals authorized to do the policy-specific administrative tasks.
- [Bootstrapping Databases](#)
After you register a new database with Oracle Internet Directory, you can install Oracle Internet Directory enabled Oracle Label Security on that database.
- [Synchronizing the Database and Oracle Internet Directory](#)
After you have installed and configured Oracle Internet Directory with Oracle Label Security, you should synchronize the database with OID and OLS.
- [Security Roles and Permitted Actions](#)
Oracle Label Security permits specific tasks and access levels for Oracle Internet Directory, including restrictions on directory-enabled OLS policy creators.
- [Superseded PL/SQL Statements When OID Is Enabled with OLS](#)
When Oracle Internet Directory is enabled with Oracle Label Security, there are several procedures that are superseded.

- [Oracle Label Security Procedures for Policy Administrators](#)
Several procedures in the `SA_POLICY_ADMIN` PL/SQL package are allowed to be run only by policy administrators (enterprise users defined in Oracle Internet Directory).

About Label Management on Oracle Internet Directory

Managing Oracle Label Security metadata in a centralized LDAP repository provides many benefits.

- You can easily provision policies and user label authorizations, and distribute them throughout the enterprise.
- When employees are terminated, you can revoke their label authorizations in one place and the change automatically propagates throughout the enterprise.

Previous releases of Oracle Label Security relied on the Oracle Database as the central repository for policy and user label authorizations. This leveraged the scalability and high availability of the Oracle Database, but not the identity management infrastructure, which includes the Oracle Internet Directory (OID). Integrating your installation of Oracle Label Security with Oracle Internet Directory allows label authorizations as part of your standard provisioning process.

These advantages apply also to directory-stored information about policies, user labels, and privileges that Oracle Label Security assigns to users. These labels and privileges are specific to the installation policies defining access control on tables and schemas. If a site is not using Oracle Internet Directory, then such information is stored locally in the database.

The following Oracle Label Security information is stored in the directory:

- Policy information, specifically policy name, column name, policy enforcement options, and audit options
- User profiles identifying their labels and privileges
- Policy label components: levels, compartments, and groups
- Policy data labels

Database-specific metadata, such as the following, is not stored in the directory:

- Lists of schemas or tables, with associated policy information
- Program units, with associated policy privileges

Note the following important aspects of integrating an Oracle Label Security installation with Oracle Internet Directory (OID):



Note:

Oracle will continue to support both the database and directory-based (OID) architectures for Oracle Label Security. However, a single database environment cannot host both architectures. Administrators must decide whether to use the centralized LDAP administration model or the database-centric model.

 **Note:**

You can manage Oracle Label Security policies directly in the directory using the Oracle Label Security administration tool (`olsadmintool`).

You can also use the graphical user interface provided by Oracle Enterprise Manager to manage Oracle Label Security. The Oracle Enterprise Manager help contains detailed documentation.

For sites that use Oracle Internet Directory, databases retrieve Oracle Label Security policy information from the directory. Administrators use the `olsadmintool` policy administration tool or the Enterprise Manager graphical user interface to operate directly on the directory to insert, alter, or remove metadata as needed. Because enterprise users can log in to multiple databases using the credentials stored in Oracle Internet Directory, it is logical to store their Oracle Label Security policy authorizations and privileges there as well. An administrator can then modify these authorizations and privileges by updating such metadata in the directory.

For distributed databases, centralized policy management removes the need for replicating policies, because the appropriate policy information is available in the directory. Changes are effective without further effort, synchronized with policy information in the databases by means of the Directory Integration Platform.

 **See Also:**

Synchronization using the Directory Integration Platform is described in the *Oracle Identity Management Integration Guide*

Figure 7-1 illustrates the structure of metadata storage in Oracle Internet Directory.

Figure 7-1 Diagram of Oracle Label Security Metadata Storage in Oracle Internet Directory

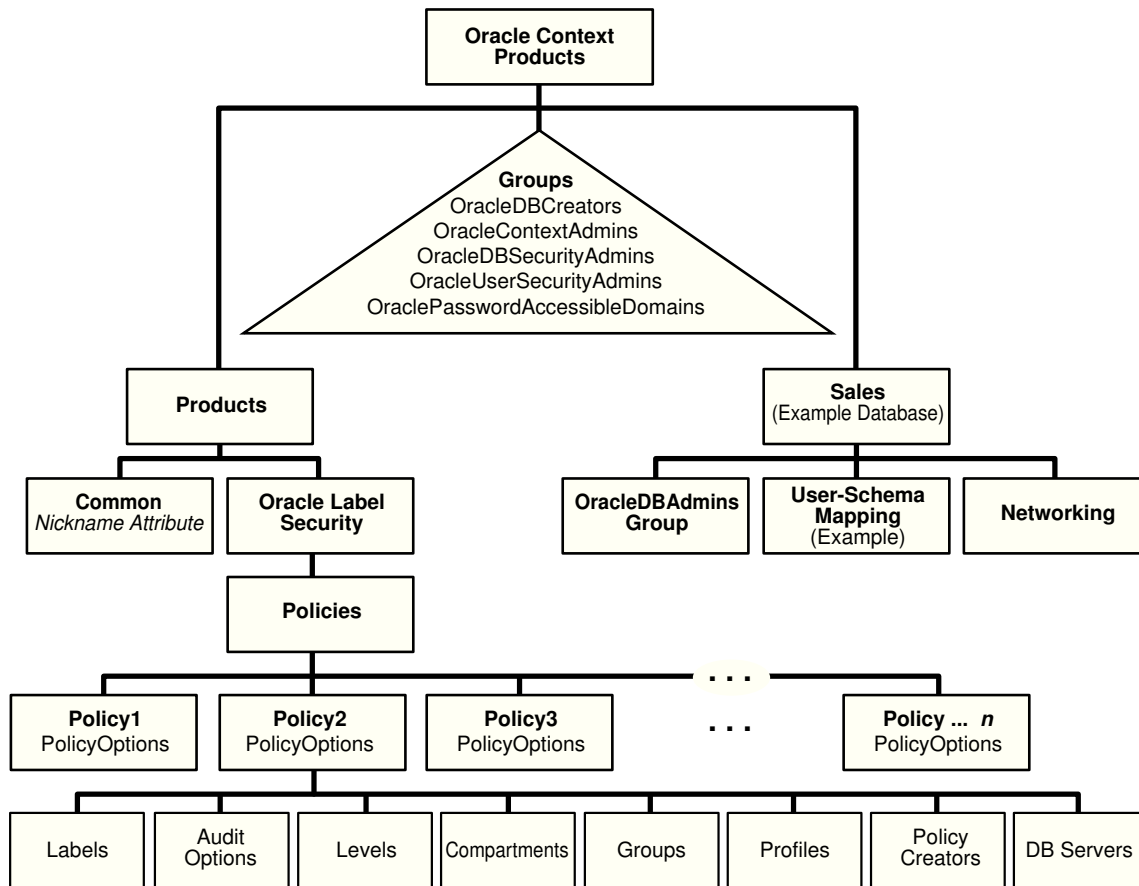
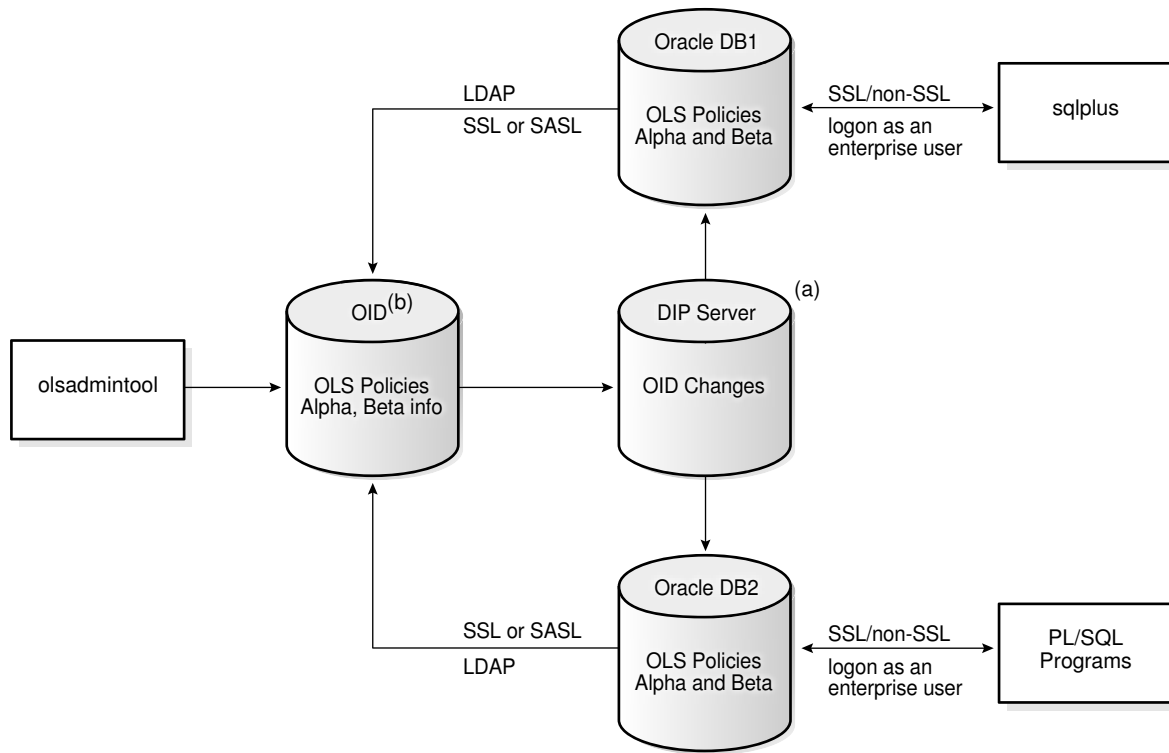

Figure 7-2 illustrates how different policies stored in Oracle Internet Directory apply to the databases accessed by different enterprise users. Directory entries corresponding to the user and the accessed database determine the policy to be applied.

Figure 7-2 Oracle Label Security Policies Applied through Oracle Internet Directory



1. Multiple OLS policy attributes
2. Enterprise users with OLS attributes

Notes:

- a. Directory Integration Platform (DIP) provisioning / synchronizing profile in Oracle Internet Directory (OID) changeable using oidprovtool.
- b. User profile in OID changeable using olsadmintool.

In this figure, the directory has information about two Oracle Label Security policies, Alpha, applying to database DB1, and Beta, applying to database DB2. Although both policies are known to each database, only the appropriate one is applied in each case. In addition, enterprise users who are to access rows protected by Oracle Label Security are listed in profiles within the Oracle Label Security attributes in Oracle Internet Directory.

As Figure 7-2 shows, the connections between different databases and the directory are established over either SSL or SASL. The database always binds to the directory as a known identity using password-based authentication. Links between databases and their clients (such as a SQL*Plus session, any PL/SQL programs, and so on) can use either SSL or non-SSL connections. The example of Figure 7-2 assumes that users are logged on through password authentication. The choice of connection type depends on the enterprise user model.

The Oracle Label Security policy administration tool operates directly on metadata in Oracle Internet Directory. Changes in the directory are then propagated to the Oracle Directory Integration and Provisioning server, which is configured to send changes to the databases at specific time intervals.

The databases update the policy information in Oracle Internet Directory only when policies are being applied to tables or schemas. These updates ensure that policies that are in use will not be dropped from the directory.

 **See Also:**

- *Oracle Database Enterprise User Security Administrator's Guide* for more information on enterprise domains, user models and authentication activities
- *Oracle Fusion Middleware Administrator's Guide for Oracle Internet Directory* for detailed information on Oracle Internet Directory

Configuring Oracle Internet Directory-Enabled Label Security

You can configure Oracle Internet Directory-enabled Oracle Label Security.

- [About Configuring Oracle Internet Directory-Enabled Label Security](#)
You can configure a database for Oracle Internet Directory-enabled Label Security after database creation or during custom database creation.
- [Granting Permissions for Configuring OID-Enabled Oracle Label Security](#)
Users who perform Oracle Internet Directory-enabled Oracle Label Security using the Database Configuration Assistant (DBCA) must have additional privileges.
- [Registering a Database and Configuring OID-Enabled Oracle Label Security](#)
The registration and configuration process entails configuring an Oracle home for the directory, performing the configuration, and setting a password and connect data.
- [Unregistration of a Database with OID-Enabled Oracle Label Security](#)
To unregister a database with Oracle Internet Directory-enabled Oracle Label Security, you can use DBCA.

About Configuring Oracle Internet Directory-Enabled Label Security

You can configure a database for Oracle Internet Directory-enabled Label Security after database creation or during custom database creation.

Oracle Internet Directory-enabled label security relies on the Enterprise User security feature.

 **See Also:**

- *Oracle Database Enterprise User Security Administrator's Guide* for prerequisites and steps to configure a database for directory usage
- *Oracle Database Enterprise User Security Administrator's Guide* for information about Database Configuration Assistant (DBCA).

Granting Permissions for Configuring OID-Enabled Oracle Label Security

Users who perform Oracle Internet Directory-enabled Oracle Label Security using the Database Configuration Assistant (DBCA) must have additional privileges.

The following steps describe what permissions are needed, and how to grant them:

1. Use Enterprise Manager to add the user to the `OracleDBCreators` group.

Oracle Database Enterprise User Security Administrator's Guide describes how to add a user to an administrative group.

2. Add the user to the Provisioning Admins group.

This is necessary because DBCA creates a `DIP` provisioning profile for Oracle Label Security. Use `ldapmodify` command with the following `.ldif` file to add a user to the Provisioning Admins group:

```
dn: cn=Provisioning Admins,cn=changelog subscriber, cn=oracle internet directory
changetype: modify
add: uniquemember
uniquemember: DN of the user who is to be added
```

3. Add the user to the `policyCreators` group using the `olsadmintool` command line tool.

DBCA bootstraps the database with the Oracle Label Security policy information from Oracle Internet Directory, and only `policyCreators` can perform this bootstrap.

4. If the database is already registered with the Oracle Internet Directory using DBCA, use Enterprise Manager to add the user to the `OracleDBAdmins` group of that database.

Note that the permissions specified earlier are also needed by the administrator who unregisters the database that has Oracle Internet Directory enabled Oracle Label Security configuration.

Registering a Database and Configuring OID-Enabled Oracle Label Security

The registration and configuration process entails configuring an Oracle home for the directory, performing the configuration, and setting a password and connect data.

- [Step 1: Configure Your Oracle Home for Directory Usage](#)
First, you must configure your Oracle home directory so that you can use Oracle Internet Directory.
- [Step 2: Configure Oracle Internet Directory for Oracle Label Security](#)
Next, you are ready to configure Oracle Internet Directory for Oracle Label security.
- [Step 2 Alternate: Configuring Database for OID-Enabled Oracle Label Security](#)
Registering the database and configuring Oracle Label Security can be done in one invocation of DBCA.
- [Step 3: Set the DIP Password and Connect Data](#)
The `DIP` user manages Oracle Internet Directory.

Step 1: Configure Your Oracle Home for Directory Usage

First, you must configure your Oracle home directory so that you can use Oracle Internet Directory.

- Follow the instructions in *Oracle Database Enterprise User Security Administrator's Guide* to configure your Oracle home for directory usage.

Step 2: Configure Oracle Internet Directory for Oracle Label Security

Next, you are ready to configure Oracle Internet Directory for Oracle Label security.

1. Register your database in the directory using Database Configuration Assistant (DBCA).
See *Oracle Database Enterprise User Security Administrator's Guide* .
2. After your database is registered in the directory, configure Label Security:
 - a. Start DBCA, select **Configure database options in a database**, and click **Next**.
 - b. Select a database and click **Next**.
 - c. Regarding the option of unregistering the database or keeping it registered, select **Keep the database registered**.
 - d. If the database is registered with Oracle Internet Directory, the **Database options** screen shows a customize button beside the Label Security check box. Select the **Label Security** option and click **Customize**.
 - e. This customize dialog has two configuration options, for standalone Oracle Label Security or for Oracle Internet Directory-enabled Oracle Label Security. Click **OID-enabled Label security configuration** and enter the Oracle Internet Directory credentials of an appropriate administrator. Click **Ok**.
 - f. Continue with the remaining DBCA steps and click **Finish** when it appears.

Note:

You can configure a standalone Oracle Label Security on a database that is registered with Oracle Internet Directory. Select the standalone option in step e.

When configuring for Oracle Internet Directory-enabled Oracle Label Security, DBCA does the following actions in addition to registering the database:

1. Creates a provisioning profile for propagating Label Security policy changes to the database.
2. Installs the required packages on the database side for Oracle Internet Directory-enabled Oracle Label Security.
3. Bootstraps the database with all the existing Label Security policy information in the Oracle Internet Directory.

Related Topics

- [Bootstrapping Databases](#)

After you register a new database with Oracle Internet Directory, you can install Oracle Internet Directory enabled Oracle Label Security on that database.

Step 2 Alternate: Configuring Database for OID-Enabled Oracle Label Security

Registering the database and configuring Oracle Label Security can be done in one invocation of DBCA.

1. Start DBCA.
2. Select **Configure database options in a database** and click **Next**.
3. Select a database and click **Next**.
4. Click **Register the database**.
5. Enter the Oracle Internet Directory credentials of an appropriate administrator, and the corresponding password for the database wallet that will be created.
6. Enter an optional Custom Database Name for the database.

The ability to specify a custom database name is new in Oracle Database 12c. By default, the database CN (first part of the DN or the distinguished name) in the directory is the `DB_UNIQUE_NAME`. You can change this to a custom value.

7. The Database options screen shows a Customize button beside the Label Security check box. Select the **Label Security** option and click **Customize**.

The Customize dialog box is displayed, showing two configuration options, for standalone Oracle Label Security or for Oracle Internet Directory-enabled Oracle Label Security.

8. Click **OID-enabled Label Security Configuration**.
9. Continue with the remaining DBCA steps and click **Finish**.

Step 3: Set the DIP Password and Connect Data

The `DIP` user manages Oracle Internet Directory.

After you configure this user's password, you must update the interface connect information in the `DIP` provisioning profile.

1. Use the command line tool `oidprovtool` to set the password for the `DIP` user and update the interface connect information in the `DIP` provisioning profile for that database with the new password.
2. Upon creation, the `DIP` profile uses a schedule value of 3600 seconds by default, meaning that Oracle Label Security changes are propagated to the database every hour. You can use `oidprovtool` to change this value if deployment considerations require that.

Once the database is configured for Oracle Internet Directory-enabled Oracle Label Security, further considerations regarding enterprise user security may apply.

 **See Also:**

- [Oracle Directory Integration and Provisioning \(DIP\) Provisioning Profiles](#)
- *Oracle Database Enterprise User Security Administrator's Guide* for further concepts, tools, steps, and procedures

Unregistration of a Database with OID-Enabled Oracle Label Security

To unregister a database with Oracle Internet Directory-enabled Oracle Label Security, you can use DBCA.

DBCA does the following in this process:

1. Deletes the `DIP` provisioning profile for the database created for Oracle Label Security.
2. Installs the required packages for standalone Oracle Label Security, so that after unregistering, Oracle Internet Directory enabled Oracle Label Security becomes standalone Oracle Label Security.

 **Note:**

- Specific instructions for database unregistration appear in the *Oracle Database Enterprise User Security Administrator's Guide*. No special steps are required when Oracle Internet Directory-enabled Oracle Label Security is configured.
- If a database has standalone Oracle Label Security, it cannot be converted to Oracle Internet Directory-enabled Oracle Label Security. You need to drop Oracle Label Security from the database and then use DBCA again to configure Oracle Internet Directory-enabled Oracle Label Security.

Oracle Label Security Profiles

A user profile is a set of user authorizations and privileges.

Profiles are maintained as part of each Oracle Label Security policy stored in the Directory. If a user is added to a profile, then the authorizations and privileges defined in that profile for that particular policy are acquired by the user, which include the following attributes:

- Five label authorizations:
 - maximum read label
 - maximum write label
 - minimum write label
 - default read label
 - default row label

- Privileges
- The list of enterprise users to whom these authorizations apply

An enterprise user can belong to only one profile, or none.

See Also:

- [Oracle Label Security Policy Attributes in Oracle Internet Directory](#)
- *Oracle Database Enterprise User Security Administrator's Guide* for more information on creating and managing enterprise users
- Oracle Enterprise Manager help for information on creating and administering Oracle Label Security profiles and policies

Integrated Capabilities When Label Security Uses the Directory

The integration of Oracle Label Security and Oracle Internet Directory enables the several capabilities.

- User/administrator actions
 - Storing multiple Oracle Label Security policies in Oracle Internet Directory
 - Managing Oracle Label Security policies and options in the directory, including
 - * creating or dropping a policy
 - * changing policy options
 - * changing audit settings
 - Creating label components for any Oracle Label Security policies by
 - * creating or removing levels, compartments, or groups
 - * assigning numeric values to levels, compartments, or groups
 - * changing long names of levels, compartments, or groups
 - * creating children groups
 - Managing enterprise users configured as users of any Oracle Label Security policies, including
 - * assigning or removing enterprise users to/from profiles within policies
 - * assigning policy-specific privileges to enterprise users, or removing them
 - * changing policy label authorizations assigned to enterprise users
 - Managing all user/administrator actions and capabilities by means of an integrated set of command line tools that monitor and manage Oracle Label Security policies in Oracle Internet Directory.
- Automatic results of Oracle Label Security
 - Limiting database policy usage to directory-defined policies only (no local policies defined or applied)

- Synchronizing changes to policies in the directory with the databases using Oracle Label Security (to apply after enterprise users reconnect)
- After changes are propagated by the Directory Integration Platform, having immediate access to enterprise users' Oracle Label Security attributes when these users log on to any database using Oracle Label Security, assuming they are configured within any Oracle Label Security policies. These attributes include users' label authorizations and users' privileges.

Oracle Label Security Policy Attributes in Oracle Internet Directory

In Oracle Internet Directory, Oracle-related metadata is stored under `cn=OracleContext`.

Within Label Security, each policy holds the information and parameters shown in [Figure 7-1](#):

When Oracle Label Security is used without Oracle Internet Directory, it supports automatic creation of data labels by means of a label function. However, when Oracle Label Security is used with Oracle Internet Directory, such functions can create labels only using data labels that are already defined in the directory.

Table 7-1 Contents of Each Policy

| Type of Entry | Contents | Meaning/Sample Usage/References |
|---------------------|---|--|
| Policy Name | The name assigned to this policy at its creation | Used in <code>olsadmintool</code> commands such as <code>olsadmintool createpolicy</code> (refer to Command-line Tools for Label Security Using Oracle Internet Directory) |
| Column Name | The name of the column that will hold the label values relevant to this policy | Column is added to database. Refer to How Policy Label Column and Label Tags Work Inserting Labeled Data How the HIDE Policy Column Option Works Oracle Label Security Reference . Used in <code>olsadmintool createpolicy</code> |
| Enforcement Options | Any combination of the following entries: <code>LABEL_DEFAULT</code> , <code>LABEL_UPDATE</code> , <code>CHECK_CONTROL</code> , <code>READ_CONTROL</code> , <code>WRITE_CONTROL</code> , <code>INSERT_CONTROL</code> , <code>DELETE_CONTROL</code> , <code>UPDATE_CONTROL</code> , <code>ALL_CONTROL</code> , or <code>NO_CONTROL</code> | Refer to the discussions in Implementing Policy Enforcement Options and Labeling Functions and Oracle Label Security Reference . Used in <code>olsadmintool createpolicy</code> and <code>olsadmintool alterpolicy</code> |
| Options | Enabled: <code>TRUE</code> or <code>FALSE</code> , Type: <code>ACCESS</code> or <code>SESSION</code> , Success: <code>SUCCESSFUL</code> , <code>UNSUCCESSFUL</code> , or <code>BOTH</code> . | Used in <code>olsadmintool audit</code> |
| Levels | Name and number for each level | Used in <code>olsadmintool create/alter/droplevel</code> |

Table 7-1 (Cont.) Contents of Each Policy

| Type of Entry | Contents | Meaning/Sample Usage/References |
|----------------|---|--|
| Compartments | Name and number for each compartment | Used in <code>olsadmintool create/alter/drop compartment</code> |
| Groups | Name, number, and parent for each group | Used in <code>olsadmintool create/alter/dropgroup</code> |
| Profiles | Maximum and default read labels, maximum and minimum write labels, default row label, list of users, and a set of privileges from this list: <code>READ, FULL, WRITEUP, WRITEDOWN, WRITEACROSS, PROFILE_ACCESS, or COMPACCESS</code> | Policies can have one or more profiles, each of which can be assigned to many users. Profiles reduce the need to set up label authorizations for individual users. All users with the same set of labels and privileges are grouped in a single profile. Each profile represents a different set of labels, privileges, and users. Each profile in a policy is unique. |
| Data Labels | Full name and number for each valid data label | Refer to Restrictions on New Data Label Creation . |
| Administrators | Name of each administrator authorized to modify the parameters within this policy. | Policy administrators can modify parameters within a policy. They are not necessarily also policy creators, who have the right to create or remove policies or policy administrators. Refer to Security Roles and Permitted Actions . |

Subscription of Policies in Directory-Enabled Label Security

In an Oracle Internet Directory-enabled Oracle Label Security, you must subscribe a policy before it can be applied (by `SA_POLICY_ADMIN.APPLY_TABLE_POLICY` or `SA_POLICY_ADMIN.APPLY_SCHEMA_POLICY`).

In a standalone Oracle Label Security installation, the `SA_POLICY_ADMIN.APPLY_TABLE_POLICY` or `SA_POLICY_ADMIN.APPLY_SCHEMA_POLICY` functions can be used directly without the need to subscribe.

Related Topics

- [SA_POLICY_ADMIN Policy Administration PL/SQL Package](#)
The `SA_POLICY_ADMIN` PL/SQL package manages Oracle Label Security policies as a whole.
- [Step 5: Apply the Policy to a Database Table or Schema](#)
After you create grant authorizations and privileges to an Oracle Label Security policy, you can apply it to a database table or schema.

Restrictions on New Data Label Creation

When Oracle Label Security is used with Oracle Internet Directory, data labels must be pre-defined in the directory.

They cannot be created dynamically by a label function, as is possible when label security is not integrated with the directory.

Administrator Duties for Oracle Internet Directory and Oracle Label Security

Administrators listed within a policy are those individuals authorized to do the policy-specific administrative tasks.

- Modify existing policy options and audit settings.
- Enable or disable auditing for a policy.
- Create or remove levels, compartments, groups or children groups.
- Modify full/long names for levels, compartment, or groups.
- Define or modify enterprise user settings, in this policy, for:
 - Privileges
 - Maximum or minimum levels
 - Read, write, or row access for levels, compartments, or groups
 - Label profiles
- Remove enterprise users from a policy.

There is a higher level of administrators, called policy creators, who can create and remove Oracle Label Security policies and the policy administrators named within them.

Bootstrapping Databases

After you register a new database with Oracle Internet Directory, you can install Oracle Internet Directory enabled Oracle Label Security on that database.

This installation process automatically creates a Directory Integration Platform (DIP) provisioning profile enabling policy information to be periodically refreshed in the future by downloading it to the database.

When configuring the database for Oracle Internet Directory enabled Oracle Label Security, the DBCA tool puts all the policy information in Oracle Internet Directory into the database.

- To bootstrap the database, run the bootstrap utility script at `$ORACLE_HOME/bin/olsoidsync` using the following parameters:

```
olsoidsync --dbconnectstring <"database connect string in host:port:sid format">  
--dbuser <database user> --dbuserpassword <database user password> [-c] [-r]  
[-b <admin context>] -h <OID host> [-p <port>] -D <bind DN> -w <bind password>
```

For example:

```
olsoidsync --dbconnectstring yippee:1521:ora101 --dbuser lbacsys  
--dbuserpassword lbacsys -c  
-b "ou=Americas,o=Oracle,c=US" -h yippee -D cn=policycreator -w Easy2rem
```

The `olsoidsync` command pulls policy information from Oracle Internet Directory and populates the information in the database. You must provide the database TNS name, the database user name, the database user's password, the administrative context (if

any), the Oracle Internet Directory host name, the bind DN and bind password, and optionally the Oracle Internet Directory port number.

The optional `-c` switch causes the command to drop all the existing policies in the database and refresh it with policy information from Oracle Internet Directory.

The optional `-r` switch causes the command to drop all the policy metadata (without dropping the policies themselves) and refresh the policies with new metadata from Oracle Internet Directory.

Without these two switches, the command will only create new policies from Oracle Internet Directory, and will halt on any errors encountered during the refresh.

Related Topics

- [Oracle Directory Integration and Provisioning \(DIP\) Provisioning Profiles](#)
The DIP server synchronizes policy changes in the directory with the connected databases, using a separate DIP provisioning profile created for each database.

Synchronizing the Database and Oracle Internet Directory

After you have installed and configured Oracle Internet Directory with Oracle Label Security, you should synchronize the database with OID and OLS.

- [About Synchronizing the Database and Oracle Internet Directory](#)
The Directory Integration Platform Oracle Directory Provisioning Service synchronizes Oracle Label Security metadata in the OID directory with the databases.
- [Oracle Directory Integration and Provisioning \(DIP\) Provisioning Profiles](#)
The DIP server synchronizes policy changes in the directory with the connected databases, using a separate DIP provisioning profile created for each database.
- [Modifying a Provisioning Profile](#)
The `oidprovtool modify` command changes the password for the `interface_connect_info` connect string.
- [Changing the Database Connection Information for a Provisioning Profile](#)
You can change the database connection information in the DIP profile.
- [Configuring OID-Enabled Oracle Label Security with Oracle Data Guard](#)
To configure Oracle Directory-Enabled Oracle Label Security to work with Oracle Data Guard, first you configure the primary database, then the secondary database.

About Synchronizing the Database and Oracle Internet Directory

The Directory Integration Platform Oracle Directory Provisioning Service synchronizes Oracle Label Security metadata in the OID directory with the databases.

Changes to the label security data in the directory are conveyed by the provisioning integration service in the form of provisioning events. A software agent receives these events and generates appropriate SQL or PL/SQL statements to update the database. After these statements are processed, Oracle Label Security data dictionaries are updated to match the changes already made in the directory.

Oracle Label Security subscribes itself to the Provisioning Integration Service automatically during installation. The provisioning service stores the information associated with each database in the form of a provisioning profile. The software agent

uses the identity of the user `DIP`, which is created as for Oracle Label Security, to connect to the database, when synchronizing the changes in Oracle Internet Directory with the database.

If the password for the user `DIP` is changed, then you must update this password in the provisioning profile of the provisioning integration service.

Oracle Directory Integration and Provisioning (DIP) Provisioning Profiles

The DIP server synchronizes policy changes in the directory with the connected databases, using a separate DIP provisioning profile created for each database.

This profile is created automatically as part of the installation process for Oracle Internet Directory-enabled Oracle Label Security. The administrator can use the provisioning tool `oidprovtool` to modify the password for a database profile, using the script `$ORACLE_HOME/bin/oidprovtool`. Each such profile contains the following information:

Table 7-2 Elements in a DIP Provisioning Profile

| Element | Name for This Element When Invoking <code>oidprovtool</code> |
|--|--|
| The LDAP host name | <code>ldap_host</code> |
| The LDAP port number | <code>ldap_port</code> |
| The user DN and password to bind to Oracle Internet Directory to retrieve policy information | <code>ldap_user</code> <code>ldap_user_password</code> |
| The database DN | <code>application_dn</code> |
| The organization DN, that is, the administrative context in which changes are being made | <code>organization_dn</code> |
| The callback function to be invoked, that is, <code>LBACSYS.OLS_DIP_NTIFY</code> | <code>interface_name</code> |
| The database connect information, which is the host name of the database, the port number used to connect to the database, the database SID, the database user name and password | <code>interface_connect_info</code> |
| Event subscriptions, including all <code>MODIFY</code> , <code>ADD</code> and <code>DELETE</code> events under <code>cn=LabelSecurity</code> in Oracle Internet Directory | <code>operation</code> |
| The time interval between synchronizations | <code>schedule</code> |

Here is an example of using `oidprovtool`, followed by an explanation of the parameters in this example:

```
oidprovtool operation=modify ldap_host=yippee ldap_port=389
ldap_user=cn=defense_admin ldap_user_password=Easy2rem
application_dn="cn=db1,cn=OracleContext,ou=Americas,o=Oracle,c=US"
organization_dn="ou=Americas,o=Oracle,c=US" interface_name=LBACSYS.OLS_DIP_NTIFY
interface_type=PLSQL interface_connect_info=yippee:1521:db1:dip:newdip schedule=60
event_subscription= "ENTRY:cn=LabelSecurity,cn=Products,cn=OracleContext,
ou=Americas,o=Oracle,c=US:ADD(*)" event_subscription=
"ENTRY:cn=LabelSecurity,cn=Products, cn=OracleContext,ou=Americas,
```

```
o=Oracle,c=US:MODIFY(*)" event_subscription="ENTRY:cn=LabelSecurity,cn=Products,
cn=OracleContext, ou=Americas,o=Oracle,c=US:DELETE"
```

This sample `oidprovtool` command creates and enables a new DIP provisioning profile with the following attributes:

- Oracle Internet Directory in host `yippee` using port `389`
- Oracle Internet Directory user bind DN: `cn=defense_admin` with password `Easy2rem`
- Database DN: `cn=db1, cn=OracleContext, ou=Americas, o=Oracle, c=US`
- Organization DN (administrative context): `ou=Americas, o=Oracle, c=US`
- Database on host `yippee`, listening on port `1521`
- Oracle SID: `db1`
- Database user: `dip` with new password `newdip`
- Interval to synchronize directory with connected databases: `60` seconds
- All the `ADD`, `MODIFY` and `DELETE` events under `cn=LabelSecurity` to be sent to DIP

To start the DIP server, use `$ORACLE_HOME/bin/oidctl`. For example:

```
oidctl server=odisrv connect=db2 config=0 instance=0 start
```

This command will start the DIP server by connecting to `db2` (the Oracle Internet Directory database) with `config` set to `0` and instance number `0`.



See also:

Oracle Identity Management Integration Guide for more information on DIP provisioning profiles

Modifying a Provisioning Profile

The `oidprovtool modify` command changes the password for the `interface_connect_info` connect string.

Before you change the password, you must temporarily disable the profile. After changing the password, you then reenables the profile.

1. Disable the profile by using the `oidprovtool .`

The syntax is as follows:

```
oidprovtool operation=disable ldap_host=host ldap_port=port
ldap_user_dn=ldap_user_dn ldap_user_password=password application_dn=app_dn
organization_dn=org_dn
```

For example:

```
oidprovtool operation=disable ldap_host=yippee ldap_port=389
```

```
ldap_user=cn=defense_admin ldap_user_password=password
application_dn="cn=db1, cn=OracleContext, ou=Americas, o=Oracle, c=US"
organization_dn="ou=Americas, o=Oracle, c=US"
```

2. Modify the password and connection information by using the following syntax:

```
oidprovtool operation=modify ldap_host=ldap_host ldap_port=port

ldap_user_dn=ldap_user_dn ldap_user_password=password application_dn=app_dn
organization_dn=org_dn interface_connect_info=new_connect_info
```

For example:

```
oidprovtool operation=modify ldap_host=yippee ldap_port=389

ldap_user=cn=defense_admin ldap_user_password=Easy2rem
application_dn="cn=dbl,cn=OracleContext,ou=Americas,o=Oracle,c=US"
organization_dn="ou=Americas,o=Oracle,c=US"
interface_connect_info=yippee:1521:dbl:dip:NewestDIPpassword
```

3. Reenable the profile by using the following syntax:

```
oidprovtool operation=enable ldap_host=host ldap_port=port
ldap_user_dn=ldap_user_dn ldap_user_password=password application_dn=app_dn
organization_dn=org_dn
```

For example

```
oidprovtool operation=enable ldap_host=yippee ldap_port=389

ldap_user=cn=defense_admin ldap_user_password=password
application_dn="cn=dbl,cn=OracleContext,ou=Americas,o=Oracle,c=US"
organization_dn="ou=Americas,o=Oracle,c=US"
```

Changing the Database Connection Information for a Provisioning Profile

You can change the database connection information in the `DIP` profile.

1. Disable the provisioning profile.

This step temporarily stops the propagation of label security changes in the directory to the database, but no data is lost. Once the profile is enabled, any label security changes that happened in the directory since the profile was disabled are synchronized with the database.

2. Update the database connection information in the profile.

3. Enable the profile.

 **Note:**

The database character set must be compatible with Oracle Internet Directory for Oracle Internet Directory-enabled Oracle Label Security to work correctly. Only then can there be successful synchronization of the Label Security metadata in Oracle Internet Directory with the Database.

 **See Also:**

- *Oracle Database Globalization Support Guide* for more information about character sets and Globalization Support parameters
- [Modifying a Provisioning Profile](#)
- *Oracle Identity Management Integration Guide* for more information about enabling and disabling of provisioning profiles

Configuring OID-Enabled Oracle Label Security with Oracle Data Guard

To configure Oracle Directory-Enabled Oracle Label Security to work with Oracle Data Guard, first you configure the primary database, then the secondary database.

- [Step 1: Set Up Directory-Enabled Oracle Label Security with Data Guard](#)
You must set up the directory-enabled Oracle Label Security with Oracle Data Guard.
- [Step 2: After the Switchover, Update the OID Provisioning Profile](#)
Once you complete the switchover operation, you must update the Oracle Internet Directory provisioning profile.

Step 1: Set Up Directory-Enabled Oracle Label Security with Data Guard

You must set up the directory-enabled Oracle Label Security with Oracle Data Guard.

1. Configure Oracle Data Guard for your database.
See *Oracle Data Guard Broker* for information about installing Oracle Data Guard.
2. Register Oracle Label Security in Oracle Internet Directory on the primary database.
See [Registering a Database and Configuring OID-Enabled Oracle Label Security](#) for more information.
3. Verify that the policies have been propagated to the primary database.
 - a. Create the Oracle Label Security policies in an Oracle Internet Directory using the `olsadmintool` utility or in Oracle Enterprise Manager Cloud Control.
See [Command-line Tools for Label Security Using Oracle Internet Directory](#) for more information about using the `olsadmintool` utility.
 - b. Connect to the primary database as user `LBACSYS`.
 - c. Query the `DBA_SA_POLICIES` data dictionary view to confirm that the policies were propagated to the primary database.

```
SELECT POLICY_NAME FROM DBA_SA_POLICIES;
```
4. Connect to the standby database as user `LBACSYS` and then perform the `SELECT POLICY_NAME FROM DBA_SA_POLICIES;` query to ensure that the policies that were propagated on the primary database are on the standby database, though the redo log apply process.

5. Copy the `ewallet.p12`, `sqlnet.ora`, and `ldap.ora` files from the primary database to the standby database after the OLS-OID registration is complete.

This step is useful in case of failover and the primary database is not accessible. By default, these files are in the following locations:

- `ewallet.p12`, the wallet file, is in either the `$ORACLE_BASE/admin/Oracle_SID/wallet` directory or the `$ORACLE_HOME/admin/Oracle_SID/wallet` directory.
 - `sqlnet.ora` is in the `$ORACLE_HOME/dbs` directory. (Back up this file before copying it to the standby database.)
 - `ldap.ora` is in the `$ORACLE_HOME/dbs` directory.
6. Go to the directory where you copied the `ewallet.p12` file.
 7. Create SSO wallet file (`cwallet.sso`) associated to PKCS#12 wallet (`ewallet.p12`) by using the following syntax:

```
orapki wallet create -wallet wallet_location -auto_login [-pwd password]
```

Step 2: After the Switchover, Update the OID Provisioning Profile

Once you complete the switchover operation, you must update the Oracle Internet Directory provisioning profile.

In this step, after you have performed the switchover and completed steps 5, 6, and 7 under [Step 1: Set Up Directory-Enabled Oracle Label Security with Data Guard](#), you are ready to update the provisioning profile in Oracle Internet Directory with the connection information of the new primary database.

If you do not complete the following procedure, then the policies will continue to be propagated to the new standby database, and the old primary database will fail with an `ORA-16000 database open for read-only access error`. After you have updated the provisioning profile with the new primary database connection information, then policy propagation takes place in the new primary database. In addition, these policies are propagated to the new standby through the redo apply process.

1. On either the primary or the standby computer, run the following `oidprovtool` utility command for the new primary database.

```
oidprovtool operation=modify \
ldap_host=OID_Server_hostname ldap_port=OID_Server_Port \
ldap_user_dn="cn=orcladmin" \
application_dn="LDAP_distinguished_name_of_application" \
```

The `application_dn` setting can be derived from `dn=dbname, cn=oraclecontext, default_admin_context`. The `ldap.ora` file lists the `default_admin_context` setting.

2. When prompted, enter the LDAP user password.

```
Please enter the LDAP password:
```

3. When prompted, enter the interface connection information in the following format:

```
host:port:service_name:dip:password
```

DIP is the Oracle Directory Integration and Provisioning (DIP) account that is installed with Oracle Label Security. This account is created automatically as part of the installation process for Oracle Internet Directory-enabled Oracle Label Security.

To specify no interface connection information, omit any settings and press **Return**.

4. After you complete the provisioning profile, then restart the `DIP` server.

Security Roles and Permitted Actions

Oracle Label Security permits specific tasks and access levels for Oracle Internet Directory, including restrictions on directory-enabled OLS policy creators.

- [Permitted Tasks and Access Levels for Oracle Internet Directory](#)
To manage Oracle Label Security policies in Oracle Internet Directory, certain entities are given access control rights in the directory.
- [Restriction on Policy Creators for Directory-Enabled Oracle Label Security](#)
A member of the Policy Creators group can only create, browse, and delete Oracle Label Security policies.

Permitted Tasks and Access Levels for Oracle Internet Directory

To manage Oracle Label Security policies in Oracle Internet Directory, certain entities are given access control rights in the directory.

The access control mechanisms are provided by Oracle Internet Directory.

[Table 7-3](#) describes, in abstract terms, these entities and the tasks they are enabled to perform.

Table 7-3 Tasks That Certain Entities Can Perform

| Entity | Tasks This Entity Can Perform |
|-----------------------|--|
| Policy creators | Create new (or delete existing) policies, create new (or remove existing) policy administrators. |
| Policy administrators | For Policies: modify existing policy options and audit settings, enable or disable auditing for a policy. For Label components: create, modify, or remove levels, compartments and groups, such as by changing their full or long names or (for groups) by creating or deleting their children groups. For enterprise users: remove enterprise users from a policy, modify enterprise users' maximum or minimum levels, their read, write, and row access for compartments or groups, their privileges for a policy, and their label profiles. |

[Table 7-4](#) lists the specific access level operations permitted or disallowed for policy creators, policy administrators, and label security users.

Table 7-4 Access Levels Allowed by Users in OID

| Entries | Policy Creators | Policy Administrators | Databases |
|---------------------------------------|------------------------|-----------------------|------------|
| <code>cn=Policies</code> | can modify | no access | no access |
| <code>cn=Admins, cn=Policy1</code> | can modify | no access | no access |
| <code>uniqueMember: cn=Policy1</code> | can browse | can browse | can modify |
| <code>cn=PolicyCreators</code> | no access ¹ | no access | no access |

Table 7-4 (Cont.) Access Levels Allowed by Users in OID

| Entries | Policy Creators | Policy Administrators | Databases |
|----------------------------|------------------------|-----------------------|-----------|
| cn=Levels,cn=Policy1 | can browse and delete | can modify | no access |
| cn=Compartments,cn=Policy1 | can browse and delete | can modify | no access |
| cn=Groups,cn=Policy1 | can browse and delete | can modify | no access |
| cn=AuditOptions,cn=Policy1 | can browse and delete | can modify | no access |
| cn=Profiles,cn=Policy1 | can browse and delete | can modify | no access |
| cn=Labels,cn=Policy1 | can browse and delete | can modify | no access |
| cn=DBServers | no access ² | no access | no access |

¹ The group cn=OracleContextAdmins is the owner of the group cn=PolicyCreators, so members in cn=OracleContextAdmins can modify cn=PolicyCreators.

² The group cn=OracleDBCreators is the owner of the group cn=DBServers, so members in cn=OracleDBCreators can modify cn=DBServers.

Restriction on Policy Creators for Directory-Enabled Oracle Label Security

A member of the Policy Creators group can only create, browse, and delete Oracle Label Security policies.

This user cannot perform policy administrative tasks, such as creating label components and adding users, even if explicitly added to the Policy Admins group of that policy. In short, a policy creator cannot be the administrator of any policy.

Superseded PL/SQL Statements When OID Is Enabled with OLS

When Oracle Internet Directory is enabled with Oracle Label Security, there are several procedures that are superseded.

Only user LBACSYS is allowed to run these procedures.

For some of the procedures listed in the table, the functionality they provided is replaced by the `olsadmintool` command named in the second column (and explained in [Oracle Label Security Reference](#)).

Table 7-5 Procedures Superseded by olsadmintool When Using Oracle Internet Directory

| Disabled Procedure | Replaced by olsadmintool Command |
|----------------------------|----------------------------------|
| SA_SYSDBA.CREATE_POLICY | olsadmintool createpolicy |
| SA_SYSDBA.ALTER_POLICY | olsadmintool alterpolicy |
| SA_SYSDBA.DROP_POLICY | olsadmintool droppolicy |
| SA_COMPONENTS.CREATE_LEVEL | olsadmintool createlevel |
| SA_COMPONENTS.ALTER_LEVEL | olsadmintool alterlevel |
| SA_COMPONENTS.DROP_LEVEL | olsadmintool droplevel |

Table 7-5 (Cont.) Procedures Superseded by olsadmintool When Using Oracle Internet Directory

| Disabled Procedure | Replaced by olsadmintool Command |
|-------------------------------------|---|
| SA_COMPONENTS.CREATE_COMPARTMENT | olsadmintool createcompartment |
| SA_COMPONENTS.ALTER_COMPARTMENT | olsadmintool altercompartment |
| SA_COMPONENTS.DROP_COMPARTMENT | olsadmintool dropcompartment |
| SA_COMPONENTS.CREATE_GROUP | olsadmintool creategroup |
| SA_COMPONENTS.ALTER_GROUP | olsadmintool altergroup |
| SA_COMPONENTS.ALTER_GROUP_PARENT | olsadmintool altergroup |
| SA_COMPONENTS.DROP_GROUP | olsadmintool droppgroup |
| SA_USER_ADMIN.SET_LEVELS | None |
| SA_USER_ADMIN.SET_COMPARTMENTS | None |
| SA_USER_ADMIN.SET_GROUPS | None |
| SA_USER_ADMIN.ADD_COMPARTMENTS | None |
| SA_USER_ADMIN.ALTER_COMPARTMENTS | None |
| SA_USER_ADMIN.DROP_COMPARTMENTS | None |
| SA_USER_ADMIN.DROP_ALL_COMPARTMENTS | None |
| SA_USER_ADMIN.ADD_GROUPS | None |
| SA_USER_ADMIN.ALTER_GROUPS | None |
| SA_USER_ADMIN.DROP_GROUPS | None |
| SA_USER_ADMIN.DROP_ALL_GROUPS | None |
| SA_USER_ADMIN.SET_USER_LABELS | olsadmintool createprofile; olsadmintool adduser; olsadmintool dropprofile; olsadmintool dropuser; |
| SA_USER_ADMIN.SET_DEFAULT_LABEL | None |
| SA_USER_ADMIN.SET_ROW_LABEL | None |
| SA_USER_ADMIN.DROP_USER_ACCESS | olsadmintool dropuser |
| SA_USER_ADMIN.SET_USER_PRIVS | olsadmintool createprofile; olsadmintool adduser; olsadmintool dropprofile; olsadmintool dropuser; |
| SA_AUDIT_ADMIN.AUDIT | olsadmintool audit |
| SA_AUDIT_ADMIN.NOAUDIT | olsadmintool noaudit |
| SA_AUDIT_ADMIN.AUDIT_LABEL | None |
| SA_AUDIT_ADMIN.NOAUDIT_LABEL | None |

Oracle Label Security Procedures for Policy Administrators

Several procedures in the SA_POLICY_ADMIN PL/SQL package are allowed to be run only by policy administrators (enterprise users defined in Oracle Internet Directory).

These procedures are as follows:

- SA_POLICY_ADMIN.APPLY_SCHEMA_POLICY
- SA_POLICY_ADMIN.APPLY_TABLE_POLICY

- SA_POLICY_ADMIN.DISABLE_SCHEMA_POLICY
- SA_POLICY_ADMIN.DISABLE_TABLE_POLICY
- SA_POLICY_ADMIN.ENABLE_SCHEMA_POLICY
- SA_POLICY_ADMIN.ENABLE_TABLE_POLICY
- SA_POLICY_ADMIN.GRANT_PROG_PRIVS
- SA_POLICY_ADMIN.POLICY_SUBSCRIBE
- SA_POLICY_ADMIN.POLICY_UNSUBSCRIBE
- SA_POLICY_ADMIN.REMOVE_SCHEMA_POLICY
- SA_POLICY_ADMIN.REMOVE_TABLE_POLICY
- SA_POLICY_ADMIN.SET_PROG_PRIVS
- SA_POLICY_ADMIN.REVOKE_PROG_PRIVS

Part III

Administering an Oracle Label Security Application

Part III describes how to administer an Oracle Label Security application.

- [Implementing Policy Enforcement Options and Labeling Functions](#)
You can customize the enforcement of Oracle Label Security policies and implement labeling functions.
- [Administering and Using Trusted Stored Program Units](#)
You can use trusted stored program units to enhance system security.
- [Auditing Under Oracle Label Security](#)
You can use Oracle Label Security auditing if you have not configured your database to use unified auditing.
- [Using Oracle Label Security with a Distributed Database](#)
You should understand the special considerations for using Oracle Label Security in a distributed configuration.
- [Performing DBA Functions Under Oracle Label Security](#)
Oracle Label Security supports the standard Oracle Database utilities, but certain restrictions apply, which may require extra steps to get the expected results.
- [Releasability Using Inverse Groups](#)
Oracle Label Security can implement the releasability using inverse groups.

8

Implementing Policy Enforcement Options and Labeling Functions

You can customize the enforcement of Oracle Label Security policies and implement labeling functions.

- [Oracle Label Security Policy Enforcement Options](#)
Oracle Label Security provides a set of policy enforcement options.
- [Labeling Functions](#)
Labeling functions can compute and return a label using resources such as context variables (for example, date or username) and data values.
- [Inserting Labeled Data Using Policy Options and Labeling Functions](#)
It is important to understand how enforcement options and labeling functions affect the insertion of labeled data.
- [Updating Labeled Data Using Policy Options and Labeling Functions](#)
Users must be authorized to change rows that are protected by Oracle Label Security.
- [Deletion of Labeled Data Using Policy Options and Labeling Functions](#)
You can delete labeled data.
- [SQL Predicates with an Oracle Label Security Policy](#)
You can use a SQL predicate to provide extensibility for selective enforcement of data access rules.

Oracle Label Security Policy Enforcement Options

Oracle Label Security provides a set of policy enforcement options.

- [About Policy Enforcement Options](#)
Of all the enforcement controls that Oracle Label Security permits, the administrator must choose those that meet the needs of the given application.
- [Levels of Policy Enforcement Options](#)
You can set policy, schema, and table levels of policy enforcement.
- [Categories of Policy Enforcement Options](#)
Oracle Label Security enforces policies using three categories: label management options, access control options, and overriding options.
- [Relationships of Policy Enforcement Options](#)
Oracle Label Security has a set of policy enforcement options.
- [How the HIDE Policy Column Option Works](#)
You can specify the `HIDE` policy configuration option when you add an Oracle Label Security policy column to a table.
- [How the Label Management Enforcement Options Work](#)
The three label enforcement options control the data label written when a row is inserted or updated.

- [How the Access Control Enforcement Options Work](#)
Access control options limit the rows accessible for `SELECT`, `UPDATE`, `INSERT`, or `DELETE` operations to only those rows whose labels meet established policies.
- [How the Overriding Enforcement Options Work](#)
Whereas `ALL_CONTROL` applies all of the label management and access control enforcement options, `NO_CONTROL` applies none of them.
- [Guidelines for Using the Policy Enforcement Options](#)
You can customize policy enforcement for a schema or table through the Oracle Enterprise Manager.
- [Exemptions from Oracle Label Security Policy Enforcement](#)
Oracle Label Security has several exceptions from OLS policy enforcement.
- [Data Dictionary Views for Viewing Policy Options on Tables and Schemas](#)
Oracle Label Security provides data dictionary views that describe the policy enforcement options currently applied to tables and schemas.

About Policy Enforcement Options

Of all the enforcement controls that Oracle Label Security permits, the administrator must choose those that meet the needs of the given application.

This means identifying levels of data sensitivity to exposure, alteration, or misuse, as well as identifying which users have the need or the right to access or alter such data. The policy enforcement options enable administrators to fine-tune users' abilities to read or write data or labels.

Levels of Policy Enforcement Options

You can set policy, schema, and table levels of policy enforcement.

[Table 8-1](#) lists the levels on which policy enforcement options can operate.

Table 8-1 When Policy Enforcement Options Take Effect

| Level at which option set | Options set at this level affect user operations ... |
|---------------------------|--|
| Policy level | ... only when the policy has been applied to the table or schema |
| Schema level | ... whenever a user acts in this schema |
| Table level | ... whenever a user acts in this table |

When you apply a policy to a table or schema, you can specify the enforcement options that are to constrain use of that table or schema. If you do not specify enforcement options at that time, then the default enforcement options you specified when you created that policy are used automatically.

These options customize your policy enforcement to meet your security requirements as to `READ` access, `WRITE` access, and label changes. You can also specify whether the label column should be displayed or hidden. You can choose to enforce some or all of the policy options for any protected table by specifying only those you want.

Optionally, you can assign each table a labeling function, which determines the label of any row inserted or updated in that table. You can also specify, optionally, a `SQL` predicate for a table, to control which rows are accessible to users, based on their labels.

When Oracle Label Security policy enforcement options are applied, they control which rows are accessible to view or to insert, update, or delete.

Related Topics

- [Labeling Functions](#)
Labeling functions can compute and return a label using resources such as context variables (for example, date or username) and data values.
- [SQL Predicates with an Oracle Label Security Policy](#)
You can use a SQL predicate to provide extensibility for selective enforcement of data access rules.

Categories of Policy Enforcement Options

Oracle Label Security enforces policies using three categories: label management options, access control options, and overriding options.

[Table 8-2](#) lists the categories of policy enforcement options.

- Label management options ensure that data labels written for inserted or updated rows do not violate policies set for such labels
- Access control options ensure that only rows whose labels meet established policies are accessible for `SELECT`, `UPDATE`, `INSERT`, or `DELETE` operations.
- Overriding options can suspend or apply all other enforcement options.

Table 8-2 Policy Enforcement Options

| Type of Enforcement | Option | Description |
|---|-----------------------------|--|
| How the Label Management Enforcement Options Work | <code>LABEL_DEFAULT</code> | Uses the session's default row label value unless the user explicitly specifies a label on <code>INSERT</code> . |
| - | <code>LABEL_UPDATE</code> | Applies policy enforcement to <code>UPDATE</code> operations that set or change the value of a label attached to a row. The <code>WRITEUP</code> , <code>WRITEDOWN</code> , and <code>WRITEACROSS</code> privileges are enforced only if the <code>LABEL_UPDATE</code> option is active. |
| - | <code>CHECK_CONTROL</code> | Applies <code>READ_CONTROL</code> policy enforcement to <code>INSERT</code> and <code>UPDATE</code> statements to assure that the new row label is read-accessible. |
| How the Access Control Enforcement Options Work | <code>READ_CONTROL</code> | Applies policy enforcement to all queries. Only authorized rows are accessible for <code>SELECT</code> , <code>UPDATE</code> , and <code>DELETE</code> operations. See INSERT_CONTROL , UPDATE_CONTROL , and DELETE_CONTROL . |
| - | <code>WRITE_CONTROL</code> | Determines the ability to <code>INSERT</code> , <code>UPDATE</code> , and <code>DELETE</code> data in a row. If this option is active, it enforces <code>INSERT_CONTROL</code> , <code>UPDATE_CONTROL</code> , and <code>DELETE_CONTROL</code> . |
| - | <code>INSERT_CONTROL</code> | Applies policy enforcement to <code>INSERT</code> operations, according to the algorithm for write access described in the figure in How Oracle Label Security Algorithm for Read Access Works . |

Table 8-2 (Cont.) Policy Enforcement Options

| Type of Enforcement | Option | Description |
|---|----------------|--|
| - | DELETE_CONTROL | Applies policy enforcement to DELETE operations, according to the algorithm for write access described in the figure in How Oracle Label Security Algorithm for Read Access Works . |
| - | UPDATE_CONTROL | Applies policy enforcement to UPDATE operations on the data columns within a row, according to the algorithm for write access described in the figure in How Oracle Label Security Algorithm for Read Access Works . |
| How the Overriding Enforcement Options Work | ALL_CONTROL | Applies all enforcement options. |
| - | NO_CONTROL | Applies no enforcement options. A labeling function or a SQL predicate can nonetheless be applied. |

Remember that even when Oracle Label Security is applicable to a table, some DML operations may not be covered by the policies being applied. The policy enforcement options set by the administrator determine both the SQL processing behavior and what an authorized user can actually see in response to a query on a protected table. Except where noted, this chapter assumes that ALL_CONTROL is active, meaning that all enforcement options are in effect. If users attempt to perform an operation for which they are not authorized, then an error message is raised and the SQL statement fails.

Understanding the relationships among these policy enforcement options, and what SQL statements they control, is essential to their effective use in designing and implementing your Oracle Label Security policies.

Related Topics

- [Implementation of Inverse Groups with INVERSE_GROUP Enforcement](#)
When creating an Oracle Label Security policy, you can specify whether the policy can use inverse group functionality to implement releasability.

Relationships of Policy Enforcement Options

Oracle Label Security has a set of policy enforcement options.

[Table 8-3](#) describes the relationships between policy enforcement options.

Table 8-3 What Policy Enforcement Options Control

| Specifying This Option in a Policy | Controls These SQL Operations | Using These Criteria and with These Effects |
|------------------------------------|-------------------------------|---|
| READ_CONTROL | SELECT, UPDATE, and DELETE | Only authorized rows (*) are accessible. |
| WRITE_CONTROL | INSERT, UPDATE, and DELETE | (a) Only authorized rows (**) are accessible (b) Data labels writable unless LABEL_UPDATE is active. |

Table 8-3 (Cont.) What Policy Enforcement Options Control

| Specifying This Option in a Policy | Controls These SQL Operations | Using These Criteria and with These Effects |
|---|-------------------------------|--|
| WRITE_CONTROL (necessary for INSERT_CONTROL, UPDATE_CONTROL, and DELETE_CONTROL) | - | - |
| INSERT_CONTROL | INSERT | - |
| UPDATE_CONTROL | UPDATE | - |
| DELETE_CONTROL | DELETE | - |
| CHECK_CONTROL | - | Applies READ_CONTROL policy enforcement to INSERT and UPDATE statements to assure that the new row label is read-accessible. |
| How the Access Control Enforcement Options Work | - | Applies policy enforcement to all queries. Only authorized rows are accessible for operations. |
| INSERT_CONTROL | INSERT_CONTROL | Applies policy enforcement to INSERT operations, according to the algorithm for write access described in the figure in How Oracle Label Security Auditing Is Enabled or Disabled . |
| DELETE_CONTROL | DELETE_CONTROL | Applies policy enforcement to DELETE operations, according to the algorithm for write access described in the figure in How Oracle Label Security Auditing Is Enabled or Disabled . |
| UPDATE_CONTROL | UPDATE_CONTROL | Applies policy enforcement to UPDATE operations on the data columns within a row, according to the algorithm for write access described in the figure in How Oracle Label Security Auditing Is Enabled or Disabled . |
| How the Overriding Enforcement Options Work | ALL_CONTROL | Applies all enforcement options. |
| NO_CONTROL | NO_CONTROL | Applies no enforcement options. A labeling function or a SQL predicate can nonetheless be applied. |

(*) A row is authorized for READ access if the following three criteria are all met: (user-minimum-level) <= (data-row-level) <= (session-level)(any-data-group) is a child of (any-user-group-or-childgroup) (every-data-compartment) is also in (the user's compartments). Refer to the figure in [How Oracle Label Security Algorithm for Read Access Works](#)

(**) A row is authorized for READ access if the following three criteria are all met: (user-minimum-level) <= (data-row-level) <= (session-level)(any-data-group) is a child of (any-user-group-or-childgroup) (every-data-compartment) is also in (the user's compartments). Refer to the figure in [How Oracle Label Security Algorithm for Read Access Works](#).

How the HIDE Policy Column Option Works

You can specify the `HIDE` policy configuration option when you add an Oracle Label Security policy column to a table.

This prevents display of the column containing the policy's labels.

Once the policy has been applied, the hidden (or not hidden) status of the column cannot be changed unless the policy is removed with the `DROP_COLUMN` parameter set to `TRUE`. Then, the policy can be reapplied with a new hidden status.

`INSERT` statements doing all-column inserts do not require the values for hidden label columns.

`SELECT` statements do not automatically return the values of hidden label columns. Such values must be explicitly retrieved.

A `DESCRIBE` on a table may or may not display the label column. If the administrator sets the `HIDE` option, then the label column will not be displayed. If `HIDE` is not specified for a policy, then the label column is displayed in response to a `SELECT`.

Related Topics

- [SA_POLICY_ADMIN.APPLY_TABLE_POLICY](#)
The `SA_POLICY_ADMIN.APPLY_TABLE_POLICY` procedure adds the specified policy to a table.
- [Retrieving All Columns from a Table When the Policy Label Column Is Hidden](#)
If the policy label column is hidden, then it is not automatically returned when you execute `SELECT *` on the table.

How the Label Management Enforcement Options Work

The three label enforcement options control the data label written when a row is inserted or updated.

- [About the Label Management Enforcement Options](#)
When a policy specifies the options and is applied to a table or schema, these options apply to special situations.
- [LABEL_DEFAULT: Using the Session's Default Row Label](#)
A user can update a row without specifying a label value, because the updated row uses its original label.
- [LABEL_UPDATE: Changing Data Labels](#)
A user updating a row can normally change its label to any label within his authorized label range.
- [CHECK_CONTROL: Checking Data Labels](#)
If an inserted or updated row gets its label from a labeling function, the label could be outside the user's authorizations.

About the Label Management Enforcement Options

When a policy specifies the options and is applied to a table or schema, these options apply to special situations.

A user inserting a row can specify any data label within the range of the user's label authorizations. If the user does not specify a label for the row being written, `LABEL_DEFAULT` can do so. Updates can be restricted by `LABEL_UPDATE`. Inserts or updates that use a labeling function need `CHECK_CONTROL` to prevent assigning a data label outside the user's authorizations. Such a label would prevent the user from accessing the row just written, and could enable the user to make data available inappropriately.

Any labeling function in force on a table overrides these options. Such a function can be named in the call that applies the policy to the table. If the administrator named such a function when applying a policy, but then disables or removes that policy, then that function is no longer applied.

Related Topics

- [SA_SYSDBA.DISABLE_POLICY](#)
The `SA_SYSDBA.DISABLE_POLICY` procedure turns off enforcement of a policy, without removing it from the database.

LABEL_DEFAULT: Using the Session's Default Row Label

A user can update a row without specifying a label value, because the updated row uses its original label.

However, to insert a new row, the user must supply a valid label unless a labeling function is in force or `LABEL_DEFAULT` applies for the table. `LABEL_DEFAULT` causes the user's session default row label to be used as the new row label.

If neither `LABEL_DEFAULT` nor a labeling function is in force and the user attempts to `INSERT` a row, then an error occurs.

Note that any labeling function in force on a table overrides the `LABEL_DEFAULT` option.

LABEL_UPDATE: Changing Data Labels

A user updating a row can normally change its label to any label within his authorized label range.

However, if `LABEL_UPDATE` applies, then to modify a label, the user must have one or more of these privileges: `WRITEUP`, `WRITEDOWN`, and `WRITEACROSS`.

The `LABEL_UPDATE` option uses an Oracle after-row trigger which is called only on an update operation affecting the label. Note that any labeling function in force on a table overrides the `LABEL_UPDATE` option.

Related Topics

- [Special Row Label Privileges](#)
Once the label on a row has been set, Oracle Label Security privileges are required to modify the label.

CHECK_CONTROL: Checking Data Labels

If an inserted or updated row gets its label from a labeling function, the label could be outside the user's authorizations.

This prevents this user from being able to read or update the row. To prevent this problem, use the `CHECK_CONTROL` setting to allow `READ_CONTROL` to apply to the new label.

This ensures that this user will be authorized to read the inserted or updated row after the operation. If not, then the insert or update operation is canceled and has no effect.

In other words, if `CHECK_CONTROL` is included as an option in a policy being enforced on a row, then the user modifying that row must still be able to access it after the operation. `CHECK_CONTROL` prevents a user or a labeling function from modifying a row's label to include a level, group, or compartment that the modifying user would be prevented from accessing.

Note that `CHECK_CONTROL` overrides any labeling function in force on a table.

How the Access Control Enforcement Options Work

Access control options limit the rows accessible for `SELECT`, `UPDATE`, `INSERT`, or `DELETE` operations to only those rows whose labels meet established policies.

- **READ_CONTROL: Reading Data**
`READ_CONTROL` limits the set of records accessible to a session for `SELECT`, `UPDATE` and `DELETE` operations.
- **WRITE_CONTROL: Writing Data**
When an Oracle Label Security policy specifying the `WRITE_CONTROL` option is applied to a table, triggers are generated and the algorithm is enforced.
- **INSERT_CONTROL, UPDATE_CONTROL, and DELETE_CONTROL**
The `INSERT_CONTROL`, `UPDATE_CONTROL`, and `DELETE_CONTROL` options control policy enforcement during the corresponding operations on the data columns in a row.

READ_CONTROL: Reading Data

`READ_CONTROL` limits the set of records accessible to a session for `SELECT`, `UPDATE` and `DELETE` operations.

If `READ_CONTROL` is not active, then even rows in the table protected by the policy are accessible to all users.

`READ_CONTROL` uses Oracle virtual private database (VPD) technology to enforce the read access mediation algorithm illustrated in [Figure 3-6](#).

WRITE_CONTROL: Writing Data

When an Oracle Label Security policy specifying the `WRITE_CONTROL` option is applied to a table, triggers are generated and the algorithm is enforced.

`WRITE_CONTROL` uses Oracle after-row triggers to enforce the write access mediation algorithm illustrated in [Figure 3-7](#).



Note:

The protection implementation for `WRITE_CONTROL` is the same for all write operations, but you need not apply all write options across the board. You can apply `WRITE_CONTROL` selectively for `INSERT`, `UPDATE`, and `DELETE` operations by using the corresponding policy enforcement option (`INSERT_CONTROL`, `UPDATE_CONTROL`, and `DELETE_CONTROL`) instead of `WRITE_CONTROL`.

If `WRITE_CONTROL` is on but `LABEL_UPDATE` is not specified, then the user can change both data and labels. If you want to control updating the row labels, then specify the `LABEL_UPDATE` option in addition to `WRITE_CONTROL` when creating your policies.

INSERT_CONTROL, UPDATE_CONTROL, and DELETE_CONTROL

The `INSERT_CONTROL`, `UPDATE_CONTROL`, and `DELETE_CONTROL` options control policy enforcement during the corresponding operations on the data columns in a row.

These options apply according to the algorithm for write access described in [Figure 3-7](#).

Specifying `WRITE_CONTROL` limits all `INSERT`, `UPDATE`, and `DELETE` operations. However,

- Specifying `INSERT_CONTROL` limits insertions but not updates or deletes.
- Specifying `UPDATE_CONTROL` limits updates but not insertions or deletes.
- Specifying `DELETE_CONTROL` limits deletes but not insertions or updates.

Related Topics

- [Inserting Labeled Data Using Policy Options and Labeling Functions](#)
It is important to understand how enforcement options and labeling functions affect the insertion of labeled data.
- [Updating Labeled Data Using Policy Options and Labeling Functions](#)
Users must be authorized to change rows that are protected by Oracle Label Security.
- [Deletion of Labeled Data Using Policy Options and Labeling Functions](#)
You can delete labeled data.

How the Overriding Enforcement Options Work

Whereas `ALL_CONTROL` applies all of the label management and access control enforcement options, `NO_CONTROL` applies none of them.

In either case, labeling functions and SQL predicates can be applied. Note that the `ALL_CONTROL` option can be used only on the command line. If you apply a policy with `NO_CONTROL` specified, then a policy label column is added to the table, but the label values are `NULL`. Because no access controls are operating on the table, you can proceed to enter labels as desired. You can then set the policy enforcement options as you want. `NO_CONTROL` can be a useful option if you have a labeling function in force to label the data correctly, but want to let all users access all the data.

Guidelines for Using the Policy Enforcement Options

You can customize policy enforcement for a schema or table through the Oracle Enterprise Manager.

This functionality is described in [Creating an Oracle Label Security Policy](#) or you can use the `SA_POLICY_ADMIN` package as described in [SA_POLICY_ADMIN Policy Administration PL/SQL Package](#).

This section documents the supported keywords.

Note that when you create a policy, you can specify a string of default options to be used whenever the policy is applied without schema or table options being specified.

If a policy is first applied to a table, and then also applied to the schema containing that table, then the options on the table are not affected by the schema policy. The options of the policy originally applied to the table remain in force.

In general, administrators use the `LABEL_DEFAULT` policy option, causing data written by a user to be labeled with that user's row label. Alternatively, a labeling function can be used to label the data. If neither of these two choices is used, then a label must be specified in every `INSERT` statement. (Updates retain the row's original label.)

The following table suggests that certain combinations of policy enforcement options are useful when implementing an Oracle Label Security policy. As the table indicates, you might typically enforce `READ_CONTROL` and `WRITE_CONTROL`, choosing from among several possible combinations for setting the data label on writes.

Table 8-4 Suggested Policy Enforcement Option Combinations

| Options | Access Enforcement |
|---|--|
| <code>READ_CONTROL</code> , <code>WRITE_CONTROL</code> , <code>LABEL_DEFAULT</code> | Read and write access based on session label. Default label provided; users can insert/update both data and labels. |
| <code>READ_CONTROL</code> , <code>WRITE_CONTROL</code> , Labeling Function | Read and write access based on session label. Users can set/change only row data; all row labels are set explicitly by the labeling function. Add <code>CHECK_CONTROL</code> to restrict new labels (on insert or update) to visible range of labels. |
| <code>READ_CONTROL</code> , <code>WRITE_CONTROL</code> , <code>LABEL_UPDATE</code> | Read and write access based on session label. Users cannot change labels without privileges. Add <code>CHECK_CONTROL</code> to restrict new labels (on insert or update) to visible range. |

Related Topics

- [Authorized Levels](#)
The administrator explicitly sets the level authorization for an Oracle Label Security policy.

Exemptions from Oracle Label Security Policy Enforcement

Oracle Label Security has several exceptions from OLS policy enforcement.

These exemptions are as follows:

- Oracle Label Security is not enforced during `DIRECT` path export.
- By design, Oracle Label Security policies cannot be applied to objects in schema `SYS`. As a consequence, the `SYS` user, and users making a DBA-privileged connection to the database (such as `CONNECT AS SYSDBA`) do not have Oracle Label Security policies applied to their actions. DBAs need to be able to administer the database. It would make no sense, for example, to export part of a table due to an Oracle Label Security policy being applied. The database user `SYS` is thus always exempt from Oracle Label Security enforcement, regardless of the export mode, application, or utility used to extract data from the database.

- Similarly, database users granted the `EXEMPT ACCESS POLICY` privilege, either directly or through a database role, are exempted from some Oracle Label Security policy enforcement controls such as `READ_CONTROL` and `CHECK_CONTROL`, regardless of the export mode, application or utility used to access the database or update its data. The following policy enforcement options remain in effect even when `EXEMPT ACCESS POLICY` is granted:
 - `INSERT_CONTROL`, `UPDATE_CONTROL`, `DELETE_CONTROL`, `WRITE_CONTROL`, `LABEL_UPDATE`, and `LABEL_DEFAULT`.
 - If the Oracle Label Security policy specifies the `ALL_CONTROL` option, then all enforcement controls are applied except `READ_CONTROL` and `CHECK_CONTROL`.

`EXEMPT ACCESS POLICY` is a very powerful privilege and should be carefully managed.

Note that this privilege does not affect the enforcement of standard Oracle Database object privileges such as `SELECT`, `INSERT`, `UPDATE`, and `DELETE`. These privileges are enforced even if a user has been granted the `EXEMPT ACCESS POLICY` privilege.

Related Topics

- [Categories of Policy Enforcement Options](#)
Oracle Label Security enforces policies using three categories: label management options, access control options, and overriding options.

Data Dictionary Views for Viewing Policy Options on Tables and Schemas

Oracle Label Security provides data dictionary views that describe the policy enforcement options currently applied to tables and schemas.

- `DBA_SA_TABLE_POLICIES`
- `DBA_SA_SCHEMA_POLICIES`

Labeling Functions

Labeling functions can compute and return a label using resources such as context variables (for example, date or username) and data values.

- [Labeling Data Rows under Oracle Label Security](#)
There are three ways to label data that is being inserted or updated.
- [How Labeling Functions in Oracle Label Security Policies Works](#)
Labeling functions enable you to consider, in your rules for assigning labels, information drawn from the application context.
- [Creating a Labeling Function for a Policy](#)
You can use the `CREATE OR REPLACE FUNCTION` SQL statement to create a labeling function.
- [Specifying a Labeling Function in a Policy](#)
You can use the `SA_POLICY_ADMIN` package to specify a labeling function.

Labeling Data Rows under Oracle Label Security

There are three ways to label data that is being inserted or updated.

- You can explicitly specify a label in every `INSERT` or `UPDATE` to the table.
- You can set the `LABEL_DEFAULT` option, which causes the session's row label to be used if an explicit row label is not included in the `INSERT` or `UPDATE` statement.
- You can create a labeling function, automatically calls on every `INSERT` or `UPDATE` statement and independently of any user's authorization.

The recommended approach is to write a labeling function to implement your rules for labeling data. If you specify a labeling function, then Oracle Label Security embeds a call to that function in `INSERT` and `UPDATE` triggers to compute a label.

For example, you could create a labeling function named `my_label` to use the contents of `COL1` and `COL2` of the new row to compute and return the appropriate label for the row. Then, you could insert, into your `INSERT` or `UPDATE` statements, the following reference:

```
my_label(:new.col1,:new.col2)
```

If you do not specify a labeling function, then specify the `LABEL_DEFAULT` option. Otherwise, you must explicitly specify a label on every `INSERT` or `UPDATE` statement.

How Labeling Functions in Oracle Label Security Policies Works

Labeling functions enable you to consider, in your rules for assigning labels, information drawn from the application context.

For example, you can use as a labeling consideration the IP address to which the user is attached. There are many opportunities to use `SYS_CONTEXT` in this way.

Note:

If the SQL statement is invalid, then an error will occur when you apply the labeling function to the table or policy. You should thoroughly test a labeling function before using it with tables.

Labeling functions override the `LABEL_DEFAULT` and `LABEL_UPDATE` options.

A labeling function is called in the context of a before-row trigger. This enables you to pass in the old and new values of the data record, as well as the old and new labels.

You can construct a labeling function to permit an explicit label to be passed in by the user.

All labeling functions must have return types of the `LBACSYS.LBAC_LABEL` data type. The `TO_LBAC_DATA_LABEL` function can be used to convert a label in character string format to a data type of `LBACSYS.LBAC_LABEL`. Note that `LBACSYS` must have the `EXECUTE` privilege on your labeling function. The owner of the labeling function must have the `EXECUTE` privilege on the `TO_LBAC_DATA_LABEL` function, with the `GRANT` option.

 **Note:**

LBACSYS is a unique schema providing opaque types for Oracle Label Security.

Related Topics

- [Performing DBA Functions Under Oracle Label Security](#)
Oracle Label Security supports the standard Oracle Database utilities, but certain restrictions apply, which may require extra steps to get the expected results.

Creating a Labeling Function for a Policy

You can use the `CREATE OR REPLACE FUNCTION` SQL statement to create a labeling function.

- To use the `CREATE OR REPLACE FUNCTION` statement to create a labeling function for a policy, set the return value to `LBACSYS.LBAC_LABEL`.

For example:

```
CREATE OR REPLACE FUNCTION sa_demo.gen_emp_label
    (Job varchar2,
     Deptno number,
     Total_sal number)
    Return LBACSYS.LBAC_LABEL
as
    i_label varchar2(80);
Begin
    /***** Determine Class Level *****/
    if total_sal > 2000 then
        i_label := 'L3: ';
    elsif total_sal > 1000 then
        i_label := 'L2: ';
    else
        i_label := 'L1: ';
    end if;

    /***** Determine Compartment *****/
    IF Job in ('MANAGER','PRESIDENT') then
        i_label := i_label||'M: ';
    else
        i_label := i_label||'E: ';
    end if;

    /***** Determine Groups *****/
    i_label := i_label||'D'||to_char(deptno);
    return TO_LBAC_DATA_LABEL('human_resources',i_label);
End;
/
```

 **Note:**

When Oracle Label Security is configured to work directly with Oracle Internet Directory, dynamic label generation is disabled, because labels are managed centrally in Oracle Internet Directory, using `olsadmintool` commands. So, if the label function generates a data label using a string value that is not already established in Oracle Internet Directory, then an error message results.

Related Topics

- [Command-line Tools for Label Security Using Oracle Internet Directory](#)
Oracle Label Security provides command-line tools for using Oracle Internet Directory.

Specifying a Labeling Function in a Policy

You can use the `SA_POLICY_ADMIN` package to specify a labeling function.

- Use `SA_POLICY_ADMIN.REMOVE_TABLE_POLICY` and `SA_POLICY_ADMIN.APPLY_TABLE_POLICY` to specify the labeling function.

For example:

```
SA_POLICY_ADMIN.REMOVE_TABLE_POLICY('human_resources', 'sa_demo', 'emp');
```

```
SA_POLICY_ADMIN.APPLY_TABLE_POLICY(
  POLICY_NAME      => 'human_resources',
  SCHEMA_NAME     => 'sa_demo',
  TABLE_NAME     => 'emp',
  TABLE_OPTIONS  => 'READ_CONTROL,WRITE_CONTROL,CHECK_CONTROL',
  LABEL_FUNCTION  => 'sa_demo.gen_emp_label(:new.job,:new.deptno,:new.sal)',
  PREDICATE       => NULL);
```

Inserting Labeled Data Using Policy Options and Labeling Functions

It is important to understand how enforcement options and labeling functions affect the insertion of labeled data.

- [Outcome of Insert or Updates Operations on Data Based on Authorizations](#)
When you attempt to insert or update data based on your authorizations, the outcome depends upon what policy enforcement controls are active.
- [Label Insertions When a Labeling Function Is Specified](#)
A labeling function takes precedence over labels entered by the user.
- [Child Row Insertions in Tables with Declarative Referential Integrity](#)
If declarative referential integrity protects a parent table, then the parent row must be visible before a child row can be inserted.

Outcome of Insert or Updates Operations on Data Based on Authorizations

When you attempt to insert or update data based on your authorizations, the outcome depends upon what policy enforcement controls are active.

- If `INSERT_CONTROL` is active, then rows you insert can only have labels within your write authorizations. If you attempt to update data that you can read, but for which you do not have write authorization, an error is raised. For example, if you can read compartments A and B, but you can only write to compartment A, then if you attempt to insert data with compartment B, then the statement will fail.
- If `INSERT_CONTROL` is *not* active, then you can use any valid label on rows you insert.
- If the `CHECK_CONTROL` option is active, then rows you insert can only have labels you are authorized to read, even if the labels are generated by a labeling function.

Label Insertions When a Labeling Function Is Specified

A labeling function takes precedence over labels entered by the user.

If the administrator has set up an automatic labeling function, then no data label a user enters will have effect (unless the labeling function itself makes use of the user's proposed label). New row labels are always determined by an active labeling function, if present.

Note that a labeling function can set the label of a row being inserted to a value outside the range that the user writing that row can see. If such a function is in use, then the user can potentially insert a row but not be authorized to see that row. You can prevent this situation by specifying the `CHECK_CONTROL` option in the policy. If this option is active, then the new data label is checked against the user's read authorization, and if the user cannot read it, then the insert operation is not performed.

Child Row Insertions in Tables with Declarative Referential Integrity

If declarative referential integrity protects a parent table, then the parent row must be visible before a child row can be inserted.

The user must be able to see the parent row for the insert operation to succeed, that is, the user must have read access to the parent row.

If `READ_CONTROL` is active on the parent table, then the user's read authorization must be sufficient to authorize a `SELECT` operation on the parent row. For example, a user who cannot read department 20 cannot insert child rows for department 20. Note that all records will be visible if the user has `FULL` or `READ` privileges on the table or schema.

Updating Labeled Data Using Policy Options and Labeling Functions

Users must be authorized to change rows that are protected by Oracle Label Security.

- [Updating Labels Using CHAR_TO_LABEL](#)
To change a row label from SENSITIVE to CONFIDENTIAL, you can change the label by using the CHAR_TO_LABEL function.
- [Evaluation of Enforcement Control Options and UPDATE](#)
When you attempt to update data based on your authorizations, the outcome depends on which enforcement controls are active.
- [Updates to Labels When a Labeling Function Is Specified](#)
A labeling function takes precedence over labels entered by the user.
- [Updates to Child Rows in Tables with Declarative Referential Integrity Enabled](#)
If a child row is in a table with a referential integrity constraint, then the parent row must be visible for the update to succeed.

Updating Labels Using CHAR_TO_LABEL

To change a row label from SENSITIVE to CONFIDENTIAL, you can change the label by using the CHAR_TO_LABEL function.

- To change a row label, use the UPDATE SQL statement.

For example:

```
UPDATE emp
SET hr_label = char_to_label ('HR', 'CONFIDENTIAL')
WHERE ename = 'ESTANTON';
```

Evaluation of Enforcement Control Options and UPDATE

When you attempt to update data based on your authorizations, the outcome depends on which enforcement controls are active.

- If UPDATE_CONTROL is active, then you can only update rows whose labels fall within your write authorizations. If you attempt to update data that you can read, but for which you do not have write authorization, then an error is raised. Assume, for example, that you can read compartments A and B, but you can only write to compartment A. In this case, if you attempt to update data with compartment B, then the statement will fail.
- If UPDATE_CONTROL is not active, then you can update all rows to which you have read access.
- If LABEL_UPDATE is active, then you must have the appropriate privilege (WRITEUP, WRITEDOWN, or WRITEACROSS) to change a label by raising or lowering its sensitivity level, or altering its groups or compartments.
- If LABEL_UPDATE is *not* active but UPDATE_CONTROL *is* active, then you can update a label to any new label value within your write authorization.
- If CHECK_CONTROL is active, then you can only write labels you are authorized to read.

The following figure illustrates the label evaluation process for LABEL_UPDATE.

Figure 8-1 Label Evaluation Process for LABEL_UPDATE

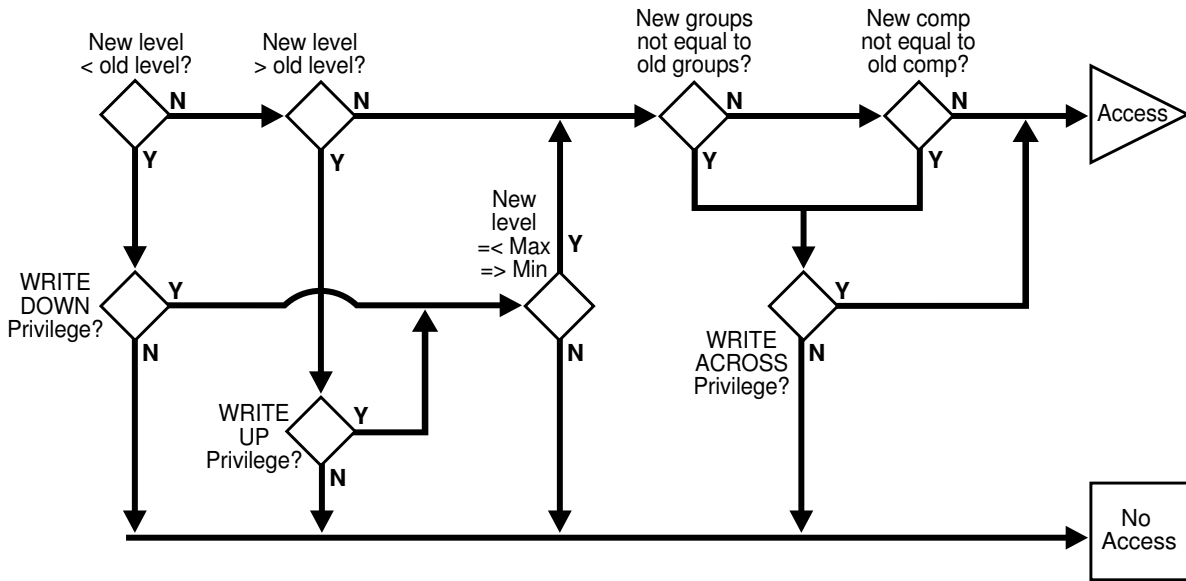

Updates to Labels When a Labeling Function Is Specified

A labeling function takes precedence over labels entered by the user.

If the administrator has set up an automatic labeling function, then no label a user enters will have effect (unless the labeling function itself makes use of the user's proposed label). New row labels are always determined by an active labeling function, if present.

Note that the security administrator can establish a labeling function that sets the label of a row being updated to a value outside the range that you can see. If this is the case, then you can update a row, but not be authorized to see the row. If the `CHECK_CONTROL` option is on, then you will not be able to perform such an update. The `CHECK_CONTROL` option verifies your read authorization on the new label.

Updates to Child Rows in Tables with Declarative Referential Integrity Enabled

If a child row is in a table with a referential integrity constraint, then the parent row must be visible for the update to succeed.

That is, this user must be able to see the parent row.

If the parent table has `READ_CONTROL` on, then the user's read authorization must be sufficient to authorize a `SELECT` on the parent row.

For example, a user who cannot read department 20 in a parent table cannot update an employee's department to department 20 in a child table. (If the user has `FULL` or `READ` privilege, then all records will be visible.)

**See Also:***Oracle Database Development Guide*

Deletion of Labeled Data Using Policy Options and Labeling Functions

You can delete labeled data.

Note the following:

- If `DELETE_CONTROL` is active, then you can delete only rows within your write authorization.
- If `DELETE_CONTROL` is *not* active, then you can delete only rows that you can read.
- With `DELETE_CONTROL` active, and declarative referential integrity defined with cascading deletes, you must have write authorization on *all* the rows to be deleted, or the statement will fail.

You cannot delete a parent row if there are any child rows attached to it, regardless of your write authorization. To delete such a parent row, you must first delete each of the child rows. If `DELETE_CONTROL` is active on any of the child rows, then you must have write authorization to delete the child rows.

Consider, for example, a situation in which the user is `UNCLASSIFIED` and there are three rows as follows:

| Row | Table | Sensitivity |
|-------------|-------|--------------|
| Parent row: | DEPT | UNCLASSIFIED |
| Child row: | EMP | UNCLASSIFIED |
| Child row: | EMP | UNCLASSIFIED |

In this case, the `UNCLASSIFIED` user cannot delete the parent row.

`DELETE_CONTROL` has no effect when `DELETERESTRICT` is active. `DELETERESTRICT` is always enforced. In some cases (depending on the user's authorizations and the data's labels) it may look as though a row has no child rows, when it actually does have children but the user cannot see them. Even if a user cannot see child rows, he still cannot delete the parent row.

SQL Predicates with an Oracle Label Security Policy

You can use a SQL predicate to provide extensibility for selective enforcement of data access rules.

- [Modifications to an Oracle Label Security Policy with a SQL Predicate](#)
A SQL predicate is a condition, optionally preceded by `AND` or `OR`.
- [How Multiple SQL Predicates Affect Oracle Label Security Policies](#)
Predicates can be appended to other predicates.

Modifications to an Oracle Label Security Policy with a SQL Predicate

A SQL predicate is a condition, optionally preceded by `AND` or `OR`.

The SQL predicate can be appended for `READ_CONTROL` access mediation. The following predicate, for example, adds an application-specific test based on `COL1` to determine if the session has access to the row.

```
AND my_function(col1)=1
```

The combined result of the policy and the user-specified predicate limits the rows that a user can read. So, this combination affects the labels and data that `CHECK_CONTROL` will permit a user to change. An `OR` clause, for example, increases the number of rows a user can read.

A SQL predicate can be useful if you want to avoid performing label-based filtering. In certain situations, a SQL predicate can easily implement row-level security on tables. Used instead of `READ_CONTROL`, a SQL predicate will filter the data for `SELECT`, `UPDATE`, and `DELETE` operations.

Similarly, in a typical, Web-enabled human resources application, a user might have to be a manager to access rows in the employee table. In such cases, the user's user label would have to dominate the label on the employee's row. A SQL predicate like the following could be added, so that an employee could bypass label-based filtering if he wanted to view his own record in the employee table. (An `OR` is used so that *either* the label policy will apply, *or* this statement will apply.)

```
OR SYS_CONTEXT ('USERENV', 'SESSION_USER') = employee_name
```

This predicate enables you to have additional access controls so that each employee can access his or her own record.

You can use such a predicate in conjunction with `READ_CONTROLS` or as a standalone predicate even if `READ_CONTROL` is not implemented.

Note:

Verify that the predicate accomplishes your security goals before you implement it in an application.

If a syntax error occurs in a predicate under Oracle Label Security, then an error will *not* arise when you try to apply the policy to a table. Rather, a predicate error message will arise when you first attempt to reference the table.

How Multiple SQL Predicates Affect Oracle Label Security Policies

Predicates can be appended to other predicates.

A predicate applied to a table with an Oracle Label Security policy is appended to other predicates that are applied by other Oracle Label Security policies, or by Oracle Database fine-grained access control or Oracle Virtual Private Database policies. The predicates are `AND`ed together.

Consider the following predicates applied to the `EMP` table in the `SCOTT` schema:

- A predicate generated by an Oracle VPD policy, such as `deptno=10`
- A label-based predicate generated by an Oracle Label Security policy, such as `label=100`, with a user-specified predicate such as

```
OR SYS_CONTEXT ('USERENV', 'SESSION_USER') = ename
```

Correct: These predicates would be `AND`ed together as follows:

```
WHERE deptno=10 AND (label=100 OR SYS_CONTEXT ('USERENV', 'SESSION_USER') = ename)
```

Incorrect: The predicates would *not* be combined in the following way:

```
WHERE deptno=10 AND label=100 OR SYS_CONTEXT ('USERENV', 'SESSION_USER') = ename
```

9

Administering and Using Trusted Stored Program Units

You can use trusted stored program units to enhance system security.

- [About Trusted Stored Program Units](#)
Oracle Database stored procedures, functions, and packages are sets of PL/SQL statements stored in a database in compiled form.
- [How a Trusted Stored Program Unit Runs](#)
A trusted stored program unit runs using its own privileges, and the caller's labels.
- [Example: Trusted Stored Program Unit](#)
A trusted stored program unit with the `READ` privilege can read all unprotected data and all data protected by this policy.
- [Creating and Compiling Trusted Stored Program Units](#)
You can create and compile trusted stored program units for use in Oracle Label Security.
- [How Setting and Returning Label Information Works](#)
The `SA_UTL` package has functions to return information about current values of session security attributes using numeric label values.

About Trusted Stored Program Units

Oracle Database stored procedures, functions, and packages are sets of PL/SQL statements stored in a database in compiled form.

The single difference between functions and procedures is that functions return a value and procedures do not. Trusted stored program units are like any other stored program units in *Oracle Database*: the underlying logic is the same.

A *package* is a set of procedures and functions, together with the cursors and variables they use, stored as a unit. There are two parts to a package, the package specification and the package body. The package specification declares the external definition of the public procedures, functions, and variables that the package contains. The package body contains the actual text of the procedures and functions, as well as any private procedures and variables.

A *trusted stored program unit* is a stored procedure, function, or package that has been granted one or more Oracle Label Security privileges. Trusted stored program units are typically used to let users perform privileged operations in a controlled manner, or update data at several labels. This is the optimal approach to permit users to access data beyond their authorization.

Trusted stored program units provide fine-grained control over the use of privileges. Although you can potentially grant privileges to many users, the granting of privileges should be done with great discretion because it might violate the security policy established for your application. Rather than assigning privileges to users, you can identify any application operations requiring privileges, and implement them as trusted

program units. When you grant privileges to these stored program units, you effectively restrict the Oracle Label Security privileges required by users. This approach employs the principle of *least privilege*.

For example, if a user with the label `CONFIDENTIAL` needs to insert data into `SENSITIVE` rows, then you can grant the `WRITEUP` privilege to a trusted stored program to which the user has access. In this way, the user can perform the task by means of the trusted stored program, while staying at the `CONFIDENTIAL` level.

The trusted program unit performs all the actions on behalf of the user. You can thus effectively encapsulate the security policy into a module that can be verified to make sure that it is valid.

How a Trusted Stored Program Unit Runs

A trusted stored program unit runs using its own privileges, and the caller's labels.

In this way, the trusted stored program unit can perform privileged operations on the set of rows constrained by the user's labels.

Oracle Database system and object privileges are intended to be bundled into roles. Users are then granted roles as necessary. By contrast, Oracle Label Security privileges can only be assigned to users or to stored program units. These trusted stored program units provide a more manageable mechanism than roles to control the use of Oracle Label Security privileges.

Example: Trusted Stored Program Unit

A trusted stored program unit with the `READ` privilege can read all unprotected data and all data protected by this policy.

Consider, for example, a user who is responsible for creating purchasing forecast reports. The user must perform a summation operation on the amount of all purchases. Regardless of whether or not user's own labels authorize access to the individual purchase orders. The syntax for creating the summation procedure in this example is as follows:

```
CREATE FUNCTION sum_purchases RETURN NUMBER IS
  psum NUMBER;
BEGIN
  SELECT SUM(amount) INTO psum
  FROM purchase_orders;
RETURN psum;
END sum_purchases;
```

In this way, the program unit can gather information the end user is not able to gather, and can make it available by means of a summation.

Note that to run `SUM_PURCHASES`, the user would need to be granted the standard Oracle Database `EXECUTE` object privilege upon this procedure.

Related Topics

- [Access Controls and Privileges](#)
Oracle provides access controls and privileges that determine the *type* of access users can have to labeled rows.

Creating and Compiling Trusted Stored Program Units

You can create and compile trusted stored program units for use in Oracle Label Security.

- [Creation of Trusted Stored Program Units](#)
You can create a trusted stored program unit in the same way that you create a standard procedure, function, or package.
- [Privileges for Trusted Stored Program Units](#)
An Oracle Label Security administrator can verify the correctness of a stored program unit code before granting the privileges to it.
- [Recompiling of Trusted Stored Program Units](#)
Recompiling a trusted stored program unit, either automatically or manually (using `ALTER PROCEDURE`), does not affect its Oracle Label Security privileges.
- [Re-creation of Trusted Stored Program Units](#)
Oracle Label Security privileges are revoked if you perform a `CREATE` or `REPLACE` operation on a trusted stored program unit.
- [Execution of Trusted Stored Program Units](#)
Under Oracle Label Security all the standard Oracle Database controls on procedure call (regarding access to tables and schemas) are still in force.

Creation of Trusted Stored Program Units

You can create a trusted stored program unit in the same way that you create a standard procedure, function, or package.

To do this, you can use the `CREATE PROCEDURE`, `CREATE FUNCTION`, or `CREATE PACKAGE` and `CREATE PACKAGE BODY` statements.

The program unit becomes trusted when you grant it Oracle Label Security privileges.

See Also:

Oracle Database SQL Language Reference

Privileges for Trusted Stored Program Units

An Oracle Label Security administrator can verify the correctness of a stored program unit code before granting the privileges to it.

Typically another user, such as a developer, creates the stored program unit. Whenever the trusted stored program unit is re-created or replaced, Oracle Label security removes its privileges. The Oracle Label Security administrator must then verify the code again and grant the privileges once again.

The Oracle Label Security administrator should review the program unit code carefully and evaluate the privileges that are to be granted to it. For example, procedures in trusted packages should not perform privileged database operations and then write result or status information into a public variable of the package. In this

way, you can make sure that no violations of your site's Oracle Label Security policy can occur.

Related Topics

- [SA_USER_ADMIN.SET_PROG_PRIVS](#)
The `SA_USER_ADMIN.SET_PROG_PRIVS` procedure sets policy-specific privileges for program units.

Recompiling of Trusted Stored Program Units

Recompiling a trusted stored program unit, either automatically or manually (using `ALTER PROCEDURE`), does not affect its Oracle Label Security privileges.

You must, however, grant the `EXECUTE` privilege on the program unit again after recompiling.

Re-creation of Trusted Stored Program Units

Oracle Label Security privileges are revoked if you perform a `CREATE` or `REPLACE` operation on a trusted stored program unit.

This limits the potential for misuse of a procedure's Oracle Label Security privileges.

Note that the procedure, function, or package can still run even if the Oracle Label Security privileges have been removed.

If you re-create a procedure, function, or package, then you should carefully review its text. When you are certain that the re-created program unit does not violate your site's Oracle Label Security policy, you can then grant it the required privileges again.

In a development environment where trusted stored program units must frequently be replaced (for example, during the first few months of a live system), it is advisable to create a script that can grant the proper Oracle Label Security privileges, as required.

Execution of Trusted Stored Program Units

Under Oracle Label Security all the standard Oracle Database controls on procedure call (regarding access to tables and schemas) are still in force.

Oracle Label Security complements these security mechanisms by controlling access to rows.

When a trusted stored program unit is carried out, the policy privileges in force are a union of the invoking user's privileges and the program unit's privileges. Whether a trusted stored program unit calls another trusted program unit or a non-trusted program unit, the program unit called runs with the same privileges as the original program unit.

If a sequence of non-trusted and trusted stored program units is carried out, the first trusted program unit will determine the privileges of the entire calling sequence from that point on. Consider the following sequence:

- Procedure A (non-trusted)
- Procedure B with `WRITEUP`
- Procedure C with `WRITEDOWN`
- Procedure D (non-trusted)

Here, Procedures B, C, and D all runs with the `WRITEUP` privilege, because B was the first trusted procedure in the sequence. When the sequence ends, the privilege pertaining to Procedure B is no longer in force for subsequent procedures.

 **Note:**

Unhandled exceptions raised in trusted program units are caught by Oracle Label Security. This means that error messages may not be displayed to the user. For this reason, you should always thoroughly test and debug any program units before granting them privileges.

How Setting and Returning Label Information Works

The `SA_UTL` package has functions to return information about current values of session security attributes using numeric label values.

Although these functions can be used in program units that are not trusted, they are primarily for use in trusted stored program units.

Note that these are public functions; you do not need the `policy_DBA` role to use them. In addition, each of the functions has a parallel `SA_SESSION` function that returns the same labels in character string format.

Related Topics

- [Duties of Oracle Label Security Administrators](#)
Oracle Label Security administrators have a set of package- and role-based privileges.

10

Auditing Under Oracle Label Security

You can use Oracle Label Security auditing if you have not configured your database to use unified auditing.

- [About Oracle Label Security Auditing](#)
Oracle Label Security auditing supplements standard Oracle Database auditing by tracking use of its own administrative operations and policy privileges.
- [Systemwide Auditing: AUDIT_TRAIL Initialization Parameter](#)
If you have not yet enabled unified auditing, for Oracle Label Security to generate audit records, you must first enable system-wide auditing.
- [How Oracle Label Security Auditing Is Enabled or Disabled](#)
After you have enabled systemwide auditing, you can enable or disable Oracle Label Security auditing.
- [Oracle Label Security and Unified Auditing](#)
Oracle Database uses the unified audit trail to capture information from various audit sources, including Oracle Label Security.
- [Oracle Label Security Auditing Tips](#)
Oracle provides a set of tips for auditing Oracle Label Security.

About Oracle Label Security Auditing

Oracle Label Security auditing supplements standard Oracle Database auditing by tracking use of its own administrative operations and policy privileges.

You can use either the `SA_AUDIT_ADMIN` package or Oracle Enterprise Manager to set and change the auditing options for an Oracle Label Security policy.

When you create a new policy, a label column for that policy is added to the database audit trail. The label column is created regardless of whether auditing is enabled or disabled, and independent of whether database auditing or operating system auditing is used. Whenever a record is written to the audit table, each policy provides a label for that record to indicate the session label. The administrator can create audit views to display these labels. Note that in the audit table, the label does not control access to the row, instead it only records the sensitivity of the row.

The auditing options that you specify apply only to subsequent sessions, not to the current session. You can specify audit options even if auditing is disabled. No overhead is created by making only these specifications. When you do enable Oracle Label Security auditing, the options come into effect, and overhead is created beyond that created by standard Oracle Database auditing.

Note that Oracle Label Security does not provide labels for audit data written to the operating system audit trail. All Oracle Label Security audit records are written directly to the database audit trail, even if operating system auditing is enabled. If auditing is disabled, then no Oracle Label Security audit records are generated.

Systemwide Auditing: AUDIT_TRAIL Initialization Parameter

If you have not yet enabled unified auditing, for Oracle Label Security to generate audit records, you must first enable system-wide auditing.

To enable system-wide auditing, you can set the Oracle Database `AUDIT_TRAIL` initialization parameter in the database's parameter file.

You can set the `AUDIT_TRAIL` parameter to one of the following values:

Table 10-1 AUDIT_TRAIL Parameter Settings

| Setting | Explanation |
|--------------|---|
| DB | Enables database auditing and directs all audit records to the database audit trail. This approach is recommended by Oracle. Note that even with <code>AUDIT_TRAIL</code> set to <code>DB</code> , some records are always sent to the operating system audit trail. These include <code>STARTUP</code> and <code>SHUTDOWN</code> statements, as well as <code>CONNECT AS SYSOPER</code> or <code>SYSDBA</code> . |
| DB, EXTENDED | Does all actions of <code>AUDIT_TRAIL=DB</code> and also populates the <code>SqlBind</code> and <code>SqlText</code> CLOB-type columns of the <code>AUD\$</code> table. |
| OS | Enables operating system auditing. This directs most of your Oracle Database audit records to the operating system, rather than to the database; the records will not contain Oracle Label Security labels. By contrast, any Oracle Label Security auditing will go to the database, with labels. If you set <code>AUDIT_TRAIL</code> to <code>OS</code> , then the Oracle Label Security-specific audit records are written to the database audit trail and the other Oracle Database audit records are written to the operating system audit trail (with no policy column in the operating system data). |
| NONE | Disables auditing. This is the default. |

After you have edited the parameter file, restart the database instance to enable or disable database auditing as specified.

Set the `AUDIT_TRAIL` parameter before you set audit options. If you do not set this parameter, then you are still able to set audit options. However, audit records are not written to the database until the parameter is set and the database instance is restarted.

See Also:

- *Oracle Database Security Guide* for information about enabling and disabling systemwide auditing, setting audit options, and managing the audit trail
- *Oracle Database Reference* or information about editing initialization parameter
- *Oracle Database SQL Language Reference* for details about systemwide `AUDIT` and `NOAUDIT` functioning

How Oracle Label Security Auditing Is Enabled or Disabled

After you have enabled systemwide auditing, you can enable or disable Oracle Label Security auditing.

To use Oracle Label Security auditing, you must have the `policy_DBA` role and use the `SA_AUDIT_ADMIN` PL/SQL package procedures.

Related Topics

- [SA_AUDIT_ADMIN Oracle Label Security Auditing PL/SQL Package](#)
For a non-unified auditing environment, the `SA_AUDIT_ADMIN` PL/SQL package configures auditing that is specific to Oracle Label Security.

Oracle Label Security and Unified Auditing

Oracle Database uses the unified audit trail to capture information from various audit sources, including Oracle Label Security.

You can configure OLS auditing using audit policies. Oracle Label Security auditing in Oracle Database 12c release 1 (12.1) enables you to audit additional events such as enabling and disabling of OLS policies.

If you have upgraded your database to Oracle Database 12c release 1 (12.1), but have not configured it to use unified auditing, then you must use the pre-12c OLS auditing described in this chapter.

The Oracle Database audit facility lets you hold database users accountable for the operations they perform. It can track specific database objects, operations, users, and privileges. Oracle Label Security supplements this by tracking use of its own administrative operations and policy privileges. It provides the `SA_AUDIT_ADMIN` package to set and change the policy auditing options.

See Also:

Oracle Database Security Guide for instructions on configuring your upgraded database to use unified auditing. After migration, you can find the OLS unified audit information at *Oracle Database Security Guide*

Oracle Label Security Auditing Tips

Oracle provides a set of tips for auditing Oracle Label Security.

- [Strategy for Setting SA_AUDIT_ADMIN Options](#)
Before setting any audit options, you must devise an auditing strategy that monitors events of interest, without recording extraneous events.
- [Auditing of Privileged Operations](#)
Consider auditing any operations that require Oracle Label Security privileges.

Strategy for Setting SA_AUDIT_ADMIN Options

Before setting any audit options, you must devise an auditing strategy that monitors events of interest, without recording extraneous events.

You should periodically review this strategy, because applications, user base, configurations, and other external factors can change.

The Oracle Label Security options, and those provided by the Oracle Database audit facility, might not directly address all of your specific or application-dependent auditing requirements. However, through use of database triggers, you can audit specific events and record specific information that you cannot audit and record using the more generic audit facility.

See Also:

Oracle Database Concepts for more information about using triggers for auditing

Auditing of Privileged Operations

Consider auditing any operations that require Oracle Label Security privileges.

Because these privileges perform sensitive operations, and because their abuse could jeopardize security, you should closely monitor their dissemination and use.

11

Using Oracle Label Security with a Distributed Database

You should understand the special considerations for using Oracle Label Security in a distributed configuration.

- [About the Oracle Label Security Distributed Configuration](#)
In a network configuration that supports distributed databases, multiple Oracle Database (or other) servers can run on the same or different operating systems.
- [How Connections to a Remote Database Under Oracle Label Security Work](#)
Distributed databases act in the standard way with Oracle Label Security: the local user ends up connected as a particular remote user.
- [Session Labels and Row Labels in Remote Sessions](#)
When connecting remotely, you can directly control the session label and row label in effect when you establish the connection.
- [Labels in a Distributed Environment](#)
You should use the same label component definitions and label tags on any database that is to be protected by the policy.
- [Oracle Label Security Policies in a Distributed Environment](#)
Oracle Label Security supports all standard Oracle Database distributed configurations.
- [Replication with Oracle Label Security](#)
You should understand how to use the replication option with tables protected by Oracle Label Security policies.

About the Oracle Label Security Distributed Configuration

In a network configuration that supports distributed databases, multiple Oracle Database (or other) servers can run on the same or different operating systems.

Each cooperative server in a distributed system communicates with other clients and servers over a network.

Figure 11-1 illustrates a distributed database that includes clients and servers with and without Oracle Label Security. As described in this chapter, if you establish database links from the `WESTERN_REGION` database to the `EASTERN_REGION` database, then you can access data if your user ID on `EASTERN_REGION` is authorized to see it, even if locally (on `WESTERN_REGION`) you do not have this access.

Figure 11-1 Using Oracle Label Security with a Distributed Database

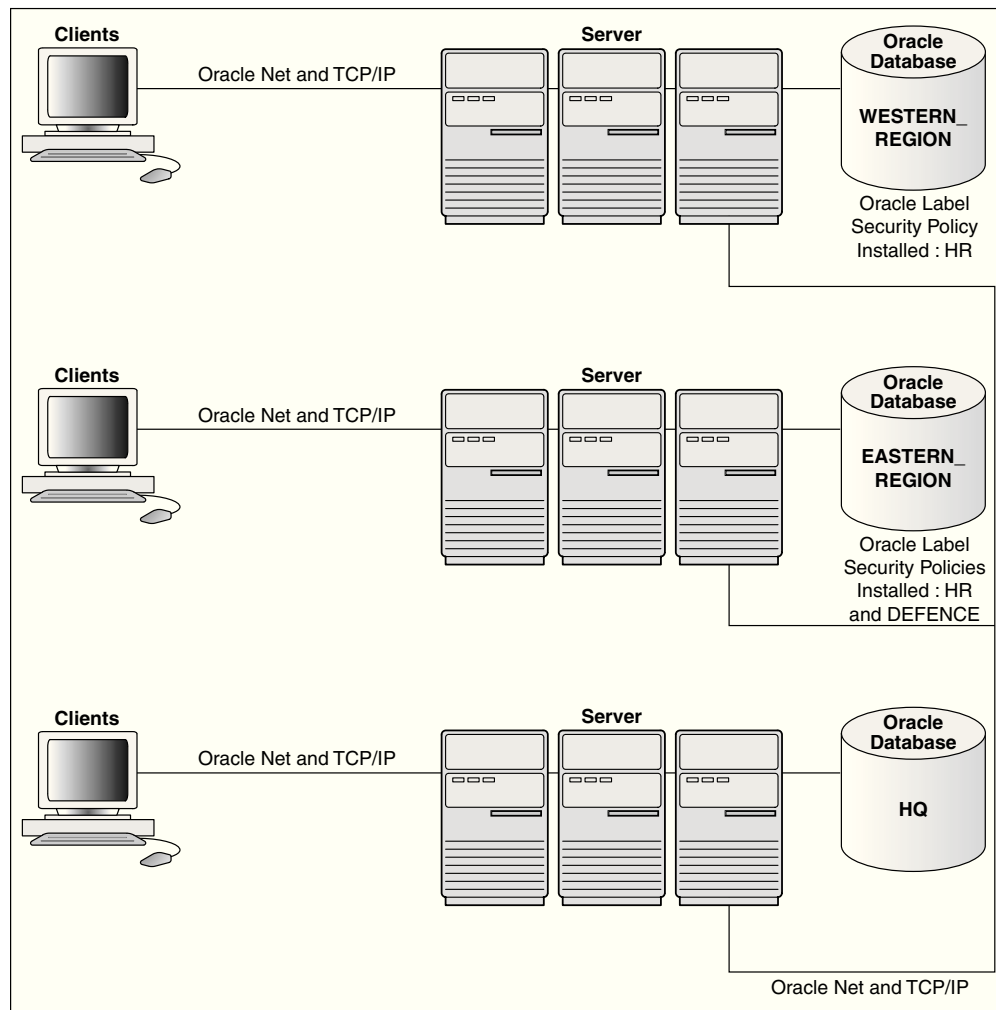

How Connections to a Remote Database Under Oracle Label Security Work

Distributed databases act in the standard way with Oracle Label Security: the local user ends up connected as a particular remote user.

Oracle Label Security protects the labeled data, whether you connect locally or remotely. If the remote user has the proper labels, then you can access the data. If not, then you cannot access the data.

The database link sets up the connection to the remote database and identifies the user who will be associated with the remote session. Your Oracle Label Security authorizations on the remote database are based on those of the remote user identified in the database link.

For example, local user `JANE` might connect as remote user `AUSTEN`, in the database referenced by the connect string `sales`, as follows:

```
CREATE DATABASE LINK sales
CONNECT TO austen IDENTIFIED BY pride
USING 'sales'
```

When JANE connects, her authorizations are based on the labels and privileges of remote user AUSTEN, because AUSTEN is the user identified in the database link. When JANE makes the first reference to the remote database, the remote session is actually established. For example, the remote session would be created if JANE enters:

```
SELECT * FROM emp@sales
```

You need not be an Oracle Label Security policy user in the local database. If you connect as a policy user on the remote database, you can access protected data.

Session Labels and Row Labels in Remote Sessions

When connecting remotely, you can directly control the session label and row label in effect when you establish the connection.

When you connect, Oracle Label Security passes these values (for all policies) over to the remote database. Notice that:

- The local session label and row label are used as the default for the remote session, if they are valid for the remote user.
- The remote session is constrained by the minimum and maximum authorizations of the remote user.
- Although the local user's session labels are passed to the remote database, the local user's privileges are not passed. The privileges for the remote session are those associated with the remote user.

Consider a local user, Diana, with a maximum level of HS, and a session level of S. On the remote database, the remote user identified in the database link has a maximum level of S.

- If Diana's session label is S when the database link is established, then the S label is passed over. This is a valid label. Diana can connect and read SENSITIVE data.
- If Diana's session label is HS when the database link is established, then the HS level is passed across, but it is not valid for the remote user. Diana will pick up the remote user's default label (S).

Be aware of the label at which you are running the first time you connect to the remote database. The first time you reference a database link, your local session labels are sent across to the remote system when a connection is made. Later, you can change the label, but to do so, you must run the SA_SESSION.SET_LABEL procedure on the remote database.

Diana can connect at level HS, set the label to S, and then perform a remote access. Connection is implicitly made when the database link is established. Her default label is S on the remote database.

On the local database, Diana can set her session label to her maximum level of HS, but if the label of the remote user is set to S, then she can only retrieve S data from the remote database. If she performs a distributed query, then she will get HS data from the local database, and S data from the remote database.

Labels in a Distributed Environment

You should use the same label component definitions and label tags on any database that is to be protected by the policy.

- [Label Tags in a Distributed Environment](#)
In a distributed environment, you may choose to use the same label tags across multiple databases.
- [Numeric Form of Label Components in a Distributed Environment](#)
In a distributed environment, the same relative ranking of the numeric form of the level component ensures that the labels are properly sorted.

Label Tags in a Distributed Environment

In a distributed environment, you may choose to use the same label tags across multiple databases.

However, if you choose *not* to use the same tags across multiple databases, then you should retrieve the character form of the label when performing remote operations. This will ensure that the labels are consistent.

In the following example, the character string representation of the label string is the same. However, the label tag does not match. If the retrieved label tag has a value of 11 on the `WESTERN_REGION` database but a tag of 2001 on the `EASTERN_REGION` database, then the tags have no meaning. Serious consequences can result.

Figure 11-2 Label Tags in a Distributed Database

| EASTERN_REGION | | WESTERN_REGION | |
|----------------|-----------|----------------|-----------|
| Label | Label Tag | Label | Label Tag |
| S:A | 3001 | S:A | 11 |
| C:A | 2001 | C:A | 6 |
| U | 10 | U | 5 |

When retrieving labels from a remote system, you should return the character string representation (rather than the numeric label tag), unless you are using the same numeric labels on both databases.

If you allow Oracle Label Security to automatically generate labels on different databases, then the label tags will not be identical. Character strings will have meaning, but the numeric values will not, unless you have predefined labels with the same label tags on both instances.

To avoid the complexities of label tags, you can convert labels to strings on retrieval (using `LABEL_TO_CHAR`) and use `CHAR_TO_LABEL` when you store labels. Operations will succeed as long as the component names are the same.

Numeric Form of Label Components in a Distributed Environment

In a distributed environment, the same relative ranking of the numeric form of the level component ensures that the labels are properly sorted.

In the following example, the levels in the two databases are effectively the same. Although the numeric form is different, the relative ranking of the levels numeric form is the same. As long as the relative order of the components is the same, the labels are perceived as identical.

Figure 11-3 Label Components in a Distributed Database

| EASTERN_REGION | | WESTERN_REGION | |
|----------------|--------------|----------------|--------------|
| Level | Numeric Form | Level | Numeric Form |
| S | 30 | S | 6 |
| C | 20 | C | 5 |
| U | 10 | U | 4 |

Oracle Label Security Policies in a Distributed Environment

Oracle Label Security supports all standard Oracle Database distributed configurations.

Whether or not you can access protected data depends on the policies installed in each distributed database.

Be sure to take into account the relationships between databases in a distributed environment:

- If the same application runs on two databases and you want them to have the same protection, then you must apply the same Oracle Label Security policy to both the local and the remote databases.
- If the local and remote databases have a policy in common, then your local session label and row label will override the default labels for the remote user.
- If the remote database has a different policy than the local database, then the remote policy can restrict access to the data independent of your local policies. On the other hand, when you make a connection as a remote user who has authorization on the remote policy, you can access any data to which the remote user has access to, regardless of your local authorizations.

If the remote database has no policy applied to it, you can access its data just as you would with a standard distributed database.

Consider a situation in which three databases exist, with different Oracle Label Security policies in force:

Database 1 has Policy A and Policy B
Database 2 has Policy A
Database 3 had Policy C

Users authorized for Policy A can obtain protected data from Database 1 and Database 2. If the remote user is authorized for Policy C, then this user can obtain data from Database 3 as well.

Replication with Oracle Label Security

You should understand how to use the replication option with tables protected by Oracle Label Security policies.

- [About Replication Under Oracle Label Security](#)
You can replicate data in Oracle Label Security.
- [Contents of a Materialized View](#)
Oracle Label Security can create materialized views.
- [Requirements for Creating Materialized Views Under Oracle Label Security](#)
The requirements for creating a materialized view depend on the type of materialized view you are creating.
- [How to Refresh Materialized Views](#)
If the contents or definition of a master table changes, then you should refresh the materialized view.

About Replication Under Oracle Label Security

You can replicate data in Oracle Label Security.

- [Replication Functionality Supported by Oracle Label Security](#)
Oracle Label Security supports replication using read-only materialized views (snapshots).
- [Row-Level Security Restriction on Replication Under Oracle Label Security](#)
An Oracle Label Security policy applies Row Level Security (RLS) to a table if `READ_CONTROL` is specified as one of the policy options.

Replication Functionality Supported by Oracle Label Security

Oracle Label Security supports replication using read-only materialized views (snapshots).

Oracle Database uses materialized views for replicating data. A *materialized view* is a local copy of a local or remote master table that reflects a recent state of the master table.

As illustrated in [Figure 11-4](#), a master table is a table you wish to replicate, on a node that you designate as the master node. Using a `dblink` account, you can create a materialized view of the table in a different database. (This can also be done in the same database, and on the same system.) You can select rows from the remote master table, and copy them into the local materialized view. Here, `mvEMP` represents the materialized view of table `EMP`, and `mlog$_EMP` represents the materialized view log.

Figure 11-4 Use of Materialized Views for Replication

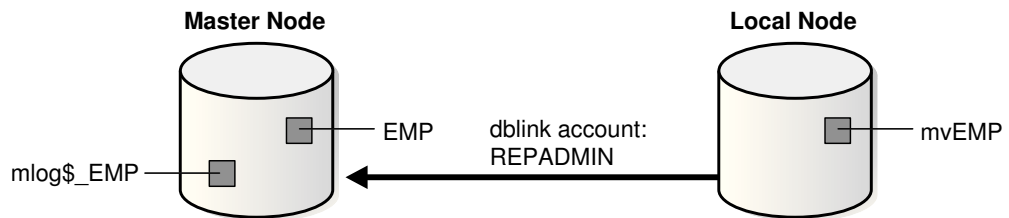

In a distributed environment, a materialized view alleviates query traffic over the network and increases data availability when a node is not available.

Row-Level Security Restriction on Replication Under Oracle Label Security

An Oracle Label Security policy applies Row Level Security (RLS) to a table if `READ_CONTROL` is specified as one of the policy options.

Problems occur if *both* of the following conditions are true:

- The Oracle Label Security policy is applied to any table relevant to replication (such as the master table, materialized view, or materialized view log), and
- The policy returns a predicate in the `WHERE` clause of `SELECT` statements.

To avoid the additional predicate (and therefore avoid this problem), the users involved in a replication environment should be given the necessary Oracle Label Security privileges. To be specific, the designated users in the database link (such as `REPADMIN` and the materialized view owner) must have the `READ` or the `FULL` privilege. As a result, the queries used to perform the replication will not be modified by RLS.

See Also:

Oracle Database 2 Day + Security Guide

Contents of a Materialized View

Oracle Label Security can create materialized views.

- [How Materialized View Contents Are Determined](#)
Oracle Label Security performs a set steps when creating materialized views.
- [Complete Materialized Views](#)
Oracle Label Security supports complete materialized views.
- [Partial Materialized Views](#)
A partial materialized view is created when you specify a `WHERE` clause in the materialized view definition.

How Materialized View Contents Are Determined

Oracle Label Security performs a set steps when creating materialized views.

The following steps determine the contents of the view:

1. It reads the definition of the master table in the remote database.
2. It reads the rows in the master table that meet the conditions defined in the materialized view definition.
3. It writes these rows to the materialized view in the local database.

Because Oracle Label Security writes only those rows to which you have write access in the local database, the contents of the materialized view vary according to:

- The policy options in effect
- The privileges you have defined in the local database
- The session label

Complete Materialized Views

Oracle Label Security supports complete materialized views.

If you read all of the rows in the master table and have write access in the local database to each label in the materialized view, then the result is a complete materialized view of the master table. To ensure that the materialized view is complete, you should have read access to all of the data in the master table and write access in the local database to all labels at which data is stored in the master table.



Note:

Never revoke privileges that you granted when you created the materialized view. If you do, then you may not be able to perform a replication refresh.

Partial Materialized Views

A partial materialized view is created when you specify a `WHERE` clause in the materialized view definition.

A partial materialized view is a convenient way to pass subsets of data to a remote database.

To create a partial materialized view, a user must have write access to all the rows being replicated. You can find the currently granted privileges for a user by querying the `DBA_SA_USER_PRIVS` data dictionary view.

Requirements for Creating Materialized Views Under Oracle Label Security

The requirements for creating a materialized view depend on the type of materialized view you are creating.

- [Requirements for a Replication Administrator](#)
Requirements for a replication administrator, typically using a `REPADMIN` account, vary depending on the configuration.

- [Requirements for the Owner of the Materialized View](#)
The privileges that belong to the owner of the materialized view are used during the refresh of the materialized view.
- [Requirements for Creating Partial Multilevel Materialized Views](#)
A partial materialized view can include only some of the rows in a remote master table that is protected by Oracle Label Security.
- [Requirements for Creating Complete Multilevel Materialized Views](#)
A complete materialized view can include every row in a remote master table that is protected by Oracle Label Security.

Requirements for a Replication Administrator

Requirements for a replication administrator, typically using a `REPADMIN` account, vary depending on the configuration.

In general, however, it should meet the following requirements:

- It must have the `FULL` Oracle Label Security privilege (mandatory for all configurations).
- It must have the `SELECT` privilege on the master table.
- It must be the account that establishes the database link from the remote node to the database containing the master table.

Requirements for the Owner of the Materialized View

The privileges that belong to the owner of the materialized view are used during the refresh of the materialized view.

If these privileges are not sufficient, then there are two options:

- The materialized view can be created in the `REPADMIN` account, or
- Additional privileges must be granted to the owner of the materialized view.

Consider, for example, the following materialized view created by user `SCOTT`:

```
CREATE MATERIALIZED VIEW mvemp as
SELECT *
FROM EMP@link_to_master
WHERE label_to_char(sa_label) = 'HS';
```

Here, `SCOTT` should have permission to insert records at the `HS` level in the local database. If Oracle Label Security policies are applied on the materialized view, then `SCOTT` must have the `FULL` privilege to avoid the RLS restriction.

Different configurations can be set up depending on whether Oracle Label Security policies are applied on the materialized view, what privileges are granted to the owner of the materialized view, and so on. If Oracle Label Security policies are applied to the materialized view, but `SCOTT` should not be granted the `FULL` privilege, then the `REPADMIN` account must be used to create the materialized view. `SCOTT` can then be granted the `SELECT` privilege on that table.

If no policies are applied to the materialized view, then the view can be created in `SCOTT`'s schema without any additional privileges. In this case, the materialized view should be created in such a way that a `WHERE` condition limits the records to those which `SCOTT` can read.

Finally, if SCOTT can be granted the FULL privilege, then the materialized view can be created in SCOTT'S schema, and Oracle Label Security policies can also be applied on the materialized view.

Note that the master table can have Oracle Label Security policies containing any set of policy options. If SCOTT has the FULL or the READ privilege, he can select all rows, regardless of policy options.

Requirements for Creating Partial Multilevel Materialized Views

A partial materialized view can include only some of the rows in a remote master table that is protected by Oracle Label Security.

If the partial materialized view is used in a table that Oracle Label Security protects, then you should ensure that you have sufficient privileges to WRITE in the local database at every label retrieved by your query. You can find your currently granted privileges by querying the ALL_SA_USER_PRIVS data dictionary view.

Requirements for Creating Complete Multilevel Materialized Views

A complete materialized view can include every row in a remote master table that is protected by Oracle Label Security.

If the complete materialized view is used in a table that Oracle Label Security protects, then you must be able to have WRITE access in the local database at the labels of all of the rows retrieved by the defined materialized view query. You can find your currently granted privileges by querying the ALL_SA_USER_PRIVS data dictionary view.

How to Refresh Materialized Views

If the contents or definition of a master table changes, then you should refresh the materialized view.

This ensures that the materialized view accurately reflects the contents of the master table.

To refresh a materialized view of a remote multilevel table, you must also have privileges to write in the local database at the labels of all of the rows that the materialized view query retrieves

WARNING:

A materialized view can potentially contain outdated rows if you refresh a partial or full materialized view but do not have READ access to all the rows in the master table, and consequently do not overwrite the rows in the original materialized view with the updated rows from the master table.

To ensure an accurate materialized view refresh, you should use job queues to refresh the views automatically. These processes must have sufficient privileges both to read all of the rows in the master table and to write those rows to the materialized view, ensuring that the view is completely refreshed. Remember that the privileges used by these processes are those of the materialized view owner.

 **See Also:**

Oracle Database Data Warehousing Guide for information about job queues

12

Performing DBA Functions Under Oracle Label Security

Oracle Label Security supports the standard Oracle Database utilities, but certain restrictions apply, which may require extra steps to get the expected results.

- [Oracle Data Pump Export Use with Oracle Label Security](#)
Oracle Data Pump enables high-speed movement of data and metadata from one database to another.
- [Data Pump Import Use with Oracle Label Security](#)
Oracle Data Pump enables high-speed movement of data and metadata from one database to another.
- [SQL*Loader Use with Oracle Label Security](#)
SQL*Loader moves data from external files into tables in Oracle Database.
- [Performance Tips for Oracle Label Security](#)
You can achieve optimal performance with Oracle Label Security.
- [Creation of Additional Databases After Installation](#)
You can create and configure additional databases after you install Oracle Label Security.
- [Oracle Label Security Upgrades and Downgrades](#)
You should be aware of how to manage Oracle Label Security upgrades and downgrades.

Oracle Data Pump Export Use with Oracle Label Security

Oracle Data Pump enables high-speed movement of data and metadata from one database to another.

- [Full Database Export](#)
Starting with Oracle Database 12c, Oracle Label Security metadata in the `LBACSYS` schema can be included when doing a full database export and import operation.
- [Schema and Table-Level Export](#)
The Data Pump export utility functions in the standard way under Oracle Label Security.

Full Database Export

Starting with Oracle Database 12c, Oracle Label Security metadata in the `LBACSYS` schema can be included when doing a full database export and import operation.

The source database can be Oracle Database 11g release 2 (11.2.0.3), or higher, but the target database must be Oracle Database 12c or higher.

Before starting the Data Pump import on the target database, you must enable Oracle Label Security.

Schema and Table-Level Export

The Data Pump export utility functions in the standard way under Oracle Label Security.

There are, however, a few differences resulting from the enforcement of Oracle Label Security policies.



Note:

You must have the `EXEMPT ACCESS POLICY` privilege in order to export all rows in the table, or else no rows are exported.

- For any tables protected by an Oracle Label Security policy, only rows with labels authorized for read access are exported. Unauthorized rows are not included in the export file. Consequently, to export all the data in protected tables, you must have a privilege (such as `FULL` or `READ`) that gives you complete access.
- SQL statements to reapply policies are exported along with tables and schemas that are exported. These statements are carried out during import to reapply policies with the same enforcement options as in the original database.
- The `HIDE` property is not exported. When protected tables are exported, the label columns in those tables are also exported (as numeric values). However, if a label column is hidden, then it is exported as a normal, unhidden column.
- The user must have `EXEMPT ACCESS POLICY` in order to export all rows in the table, or else no rows are exported.

Data Pump Import Use with Oracle Label Security

Oracle Data Pump enables high-speed movement of data and metadata from one database to another.

- [Full Database Import for the LBACSYS Schema Metadata](#)
Oracle Label Security metadata in the `LBACSYS` schema can be included when you perform a full database export and import operation.
- [Schema and Table Level Import](#)
You can use the Oracle Data Pump Import utility functions under Oracle Label Security.

Full Database Import for the LBACSYS Schema Metadata

Oracle Label Security metadata in the `LBACSYS` schema can be included when you perform a full database export and import operation.

The source database can be Oracle Database 11g release 2 (11.2.0.3), or higher, but the target database must be Oracle Database 12c release 1 (12.1) or higher.

Oracle Data Pump import utility, `impdp`, automatically imports Label Security metadata including policies, labels, user authorizations, schema and table policy enforcements.

You must register and enable Oracle Label Security for the target database before beginning the import operation.

Related Topics

- [Checking if Oracle Label Security Has Been Registered and Enabled](#)
You can query the `DBA_OLS_STATUS` and `CDB_OLS_STATUS` data dictionary views to find if Oracle Label Security has already been registered and enabled.

Schema and Table Level Import

You can use the Oracle Data Pump Import utility functions under Oracle Label Security.

- [Requirements for Import Under Oracle Label Security](#)
You can use the `impdp` under Oracle Label Security.
- [Definition of Data Labels for Import](#)
The label definitions at the time of import must include all the policy labels used in the export file.
- [Imports of Labeled Data Without Installing Oracle Label Security](#)
When data type for policy label columns is `NUMBER`, they can be imported into databases that do not have Oracle Label Security installed.
- [Imports of Unlabeled Data](#)
You can import unlabeled data into an existing table protected by an Oracle Label Security policy.
- [Importing Tables with Hidden Columns](#)
A hidden column is exported as a normal column, but the fact that it was hidden is lost.

Requirements for Import Under Oracle Label Security

You can use the `impdp` under Oracle Label Security.

To use the `impdp` under Oracle Label Security, you must prepare the import database and ensure that the import user has the proper authorizations.

- [Preparing the Import Database](#)
Before you can use the Import utility with Oracle Label Security, you must prepare the import database.
- [Verification of Import User Authorizations](#)
You must be authorized to run the import operation for labels required to insert data and labels in the export file.

Preparing the Import Database

Before you can use the Import utility with Oracle Label Security, you must prepare the import database.

1. Ensure that Oracle Label Security is enabled. See [Checking if Oracle Label Security Has Been Registered and Enabled](#).
2. Create any Oracle Label Security policies that protect the data to be imported.
Ensure that the policies use the same column names as in the export database.

3. Define in the import database all of the label components and individual labels used in tables being imported.
Ensure that the same tag values are assigned to the policy labels in each database. (Note that if you are importing into a database from which you exported, then the components are most likely already defined.)

Verification of Import User Authorizations

You must be authorized to run the import operation for labels required to insert data and labels in the export file.

Errors will be raised upon import if you do not meet the following requirements.

- To import tables or schemas with Label Security policies on them, you must have execute privilege on the `SA_POLICY_ADMIN` package.
To ensure that all rows can be imported, you must have the `policy_DBA` role for all policies with data being imported. After each schema or table is imported, any policies from the export database are reapplied to the imported objects.
- You must also have the ability to write all rows that have been exported as follows:
Requirement 2:
 - You can granted the `FULL` privilege or given sufficient authorization to write all labels contained in the import file.
 - A user-defined labeling function can be applied to the table.

Definition of Data Labels for Import

The label definitions at the time of import must include all the policy labels used in the export file.

The `DBA_SA_LABELS` data dictionary view lists data labels. You can use the views `DBA_SA_LEVELS`, `DBA_SA_COMPARTMENTS`, `DBA_SA_GROUPS`, and in the export database to design SQL scripts that re-create the label components and labels for each policy in the import database. The following example shows how to generate a PL/SQL block that re-creates the individual labels for the `HR` policy:

```
set serveroutput on
BEGIN
  dbms_output.put_line('BEGIN');
  FOR l IN (SELECT label_tag, label
            FROM dba_sa_labels
            WHERE policy_name='HR'
            ORDER BY label_tag) LOOP
    dbms_output.put_line
      (' SA_LABEL_ADMIN.CREATE_LABEL(''HR'', ' ||
      l.label_tag || ', '' || l.label || '');');
  END LOOP;
  dbms_output.put_line ('END;');
  dbms_output.put_line ('/');
END;
/
```

If the individual labels do not exist in the import database with the same numeric values and the same character string representations as in the export database, then the label values in the imported tables will be meaningless. The numeric label value in

the table may refer to a different character string representation, or it may be a label value that has not been defined at all in the import database.

If a user attempts to access rows containing invalid numeric labels, then the operation will fail.

Imports of Labeled Data Without Installing Oracle Label Security

When data type for policy label columns is `NUMBER`, they can be imported into databases that do not have Oracle Label Security installed.

In this case, the values in the policy label column are imported as numbers. Without the corresponding Oracle Label Security label definitions, the numbers will not reference any specific label.

Note that errors will be raised during the import if Oracle Label Security is not installed, because the SQL statements to reapply the policy to the imported tables and schemas will fail.

Imports of Unlabeled Data

You can import unlabeled data into an existing table protected by an Oracle Label Security policy.

Either the `LABEL_DEFAULT` option or a labeling function must be specified for each table being imported, so that the labels for the rows can be automatically initialized as they are inserted into the table.

Importing Tables with Hidden Columns

A hidden column is exported as a normal column, but the fact that it was hidden is lost.

If you want to preserve the hidden property of the label column, then you must first create the table in the import database.

1. Before you perform the import, create the table and apply the policy with the `HIDE` option. This adds the policy label column to the table as a hidden column.
2. Remove the policy from the table, so that the enforcement options specified in the export file can be reapplied to the table during the import operation.
3. Perform the import with `IGNORE=Y`. Setting the `IGNORE` parameter to `Y` ignores errors during import.
4. Manually apply the policy to the table with the `HIDE` option.

SQL*Loader Use with Oracle Label Security

SQL*Loader moves data from external files into tables in Oracle Database.

- [Requirements for Using SQL*Loader Under Oracle Label Security](#)
You can use SQL*Loader with the conventional path to load data into a database protected by Oracle Label Security.
- [Oracle Label Security Input to SQL*Loader](#)
If the policy column for a table is hidden, then you must use the `HIDDEN` keyword to convey this information to SQL*Loader.

Requirements for Using SQL*Loader Under Oracle Label Security

You can use SQL*Loader with the conventional path to load data into a database protected by Oracle Label Security.

Because SQL*Loader performs `INSERT` operations, all of the standard requirements apply when using SQL*Loader on tables protected by Oracle Label Security policies.

Oracle Label Security Input to SQL*Loader

If the policy column for a table is hidden, then you must use the `HIDDEN` keyword to convey this information to SQL*Loader.

To specify row labels in the input file, you must include the policy label column in the `INTO TABLE` clause in the control file.

To load policy labels along with the data for each row, you can specify the `CHAR_TO_LABEL` function or the `TO_DATA_LABEL` function in the SQL*Loader control file.



Note:

When Oracle Label Security is installed to work with Oracle Internet Directory, dynamic label generation is not allowed, because labels are managed centrally in Oracle Internet Directory, using `olsadmintool` commands.

When Oracle Label Security is directory-enabled, then the function `TO_DATA_LABEL` is not available and generates an error message if used.

Table 12-1 shows the variations that you can use when you load Oracle Label Security data with SQL*Loader.

Table 12-1 Input Choices for Oracle Label Security Input to SQL*Loader

| Form of Data | Explanation of Results |
|---|--|
| <code>col1 hidden integer external</code> | Hidden column loaded with tag value of data directly from data file |
| <code>col2 hidden char(5) "func(:col2)"</code> | Hidden column loaded with character value of data from data file. <code>func()</code> used to translate between the character label and its tag value. Note: <code>func()</code> might be <code>char_to_label()</code> . |
| <code>col3 hidden "func(:col3)"</code> | Same as in <code>col2</code> , field type defaults to char |
| <code>col4 hidden expression "func(:col4)"</code> | Hidden column not mapped to input data. <code>func()</code> will be called to provide the label value. This could be a user function. |

For example, the following is a valid `INTO TABLE` clause in a control file that is loading data into the `DEPT` table:

```
INTO TABLE dept
(hr_label HIDDEN POSITION (1:22) CHAR "CHAR_TO_LABEL('HR',:hr_label)",
deptno    POSITION (23:26) INTEGER EXTERNAL,
dname     POSITION (27:40) CHAR,
loc       POSITION(41,54) CHAR)
```

The following could be an entry in the data file specified by this control file:

```
HS:FN                231 ACCOUNTING REDWOOD SHORES
```

Related Topics

- [Command-line Tools for Label Security Using Oracle Internet Directory](#)
Oracle Label Security provides command-line tools for using Oracle Internet Directory.

Performance Tips for Oracle Label Security

You can achieve optimal performance with Oracle Label Security.

- [Use of ANALYZE to Improve Oracle Label Security Performance](#)
You can run the `ANALYZE` statement on the Oracle Label Security data dictionary tables in the `LBACSYS` schema.
- [Creation of Indexes on the Policy Label Column](#)
Creating the appropriate type of index on the policy label column improves the performance of user-raised queries on protected tables.
- [Label Tag Strategy Plan to Enhance Performance](#)
For optimal performance, you can plan a strategy for assigning values to label tags.
- [Partitioned Data Based on Numeric Label Tags](#)
Using a numeric ordering strategy with the numeric label tags applied to the labels can a basis for Oracle Database data partitioning.

Use of ANALYZE to Improve Oracle Label Security Performance

You can run the `ANALYZE` statement on the Oracle Label Security data dictionary tables in the `LBACSYS` schema.

This enables the cost-based optimizer to improve execution plans on queries, which improves Oracle Label Security performance.

Running `ANALYZE` on application tables improves the application SQL performance.

See Also:

Oracle Database SQL Language Reference for the `ANALYZE` syntax

Creation of Indexes on the Policy Label Column

Creating the appropriate type of index on the policy label column improves the performance of user-raised queries on protected tables.

If you have applied an Oracle Label Security policy on a database table in a particular schema, then you should compare the number of different labels to the amount of data. Based on this information, you can decide which type of index to create on the policy label column.

- If the cardinality of data in the policy label column (that is, the number of labels compared to the number of rows) is low, then consider creating a bitmapped index.
- If the cardinality of data in the policy label column is high, then consider creating a B-tree index.

Consider the following case, in which the `EMP` table is protected by an Oracle Label Security policy with the `READ_CONTROL` enforcement option set, and `HR_LABEL` is the name of the policy label column. A user raises the following query:

```
SELECT COUNT (*) FROM SCOTT.EMP;
```

In this situation, Oracle Label Security adds a predicate based on the label column. For example:

```
SELECT COUNT (*) FROM SCOTT.EMP
WHERE hr_label=100;
```

In this way, Oracle Label Security uses the security label to restrict the rows that are processed, based on the user's authorizations. To improve performance of this query, you could create an index on the `HR_LABEL` column.

Consider a more complex query (once again, with `READ_CONTROL` applied to the `EMP` table):

```
SELECT COUNT (*) FROM SCOTT.EMP
WHERE deptno=10
```

Again, Oracle Label Security adds a predicate based on the label column:

```
SELECT COUNT (*) FROM SCOTT.EMP
WHERE deptno=10
AND hr_label=100;
```

In this case, you might want to create a composite index based on the `DEPTNO` and `HR_LABEL` columns, to improve application performance.

Label Tag Strategy Plan to Enhance Performance

For optimal performance, you can plan a strategy for assigning values to label tags.

In general, it is best to assign higher numeric values to labels with higher sensitivity levels.

This is because, typically, many more users can see data at comparatively low levels and fewer users at higher levels can see many levels of data.

In addition, with `READ_CONTROL` set, Oracle Label Security generates a predicate that uses a `BETWEEN` clause to restrict the rows to be processed by the query. As illustrated in the following example, if the higher-sensitivity labels do not have a higher label tag than the lower-sensitivity labels, then the query will potentially examine a larger set of rows. This will affect performance.

[Table 12-2](#) shows a set of label tags assigned as follows:

Table 12-2 Label Tag Performance Example: Correct Values

| Label | Label Tag |
|--------|-----------|
| TS:A,B | 100 |
| S:A | 50 |
| S | 20 |
| U:A | 10 |

Here, a user whose maximum authorization is S:A can potentially access data at labels S:A, S, and U:A. Consider what happens when this user raises the following query:

```
SELECT COUNT (*) FROM SCOTT.EMP
```

Oracle Label Security adds a predicate that includes a `BETWEEN` clause (based on the maximum and minimum authorizations) to restrict the set of rows this user can see:

```
SELECT COUNT (*) FROM SCOTT.EMP
WHERE hr_label BETWEEN 10 AND 50;
```

Performance improves, because the query examines only a subset of data based on the user's authorizations. It does not fruitlessly process rows that the user is not authorized to access.

[Table 12-3](#) shows how unnecessary work is performed if the tag values were assigned as follows:

Table 12-3 Label Tag Performance Example: Incorrect Values

| Label | Label Tag |
|--------|-----------|
| TS:A,B | 50 |
| S:A | 100 |
| S | 20 |
| U:A | 10 |

In this case, the user with S:A authorization can see only some of the labels between 100 and 10. Although the user cannot see TS:A,B labels (that is, rows with a label tag of 50). A query would nonetheless pick up and process these rows, even though the user ultimately will not have access to them.

Partitioned Data Based on Numeric Label Tags

Using a numeric ordering strategy with the numeric label tags applied to the labels can a basis for Oracle Database data partitioning.

Depending on the application, partitioning data based on label values may or may not be useful. Consider, for example, a business-hosting CRM application to which many companies subscribe. In the same `EMP` table, there might be rows (and labels) for Subscriber 1 and Subscriber 2. That is, information for both companies can be stored in the same table, as long as it is labeled differently. In this case, employees of Subscriber 1 will never need to access data for Subscriber 2, so it might make sense

to partition based on label. You could put rows for Subscriber 1 in one partition, and rows for Subscriber2 in a different partition. When a query is raised, it will access only one or the other partition, depending on the label. Performance improves because partitions that are not relevant are not examined by the query.

The following example shows this is done. It places labels in the 2000 series on one partition, labels in the 3000 series on another partition, and labels in the 4000 series on a third partition.

```
CREATE TABLE EMPLOYEE(  
    EMPNO NUMBER(10) CONSTRAINT PK_EMPLOYEE PRIMARY KEY,  
    ENAME VARCHAR2(10),  
    JOB VARCHAR2(9),  
    MGR NUMBER(4),  
    HIREDATE DATE,  
    SAL NUMBER(7,2),  
    COMM NUMBER(7,2),  
    DEPTNO NUMBER(4),  
    HR_LABEL NUMBER(10))  
    TABLESPACE PERF_DATA  
    STORAGE (initial 2M  
    NEXT 1M  
    MINEXTENTS 1  
    MAXEXTENTS unlimited)  
    PARTITION BY RANGE (hr_label)  
    (partition sx1 VALUES LESS THAN (2000) NOLOGGING,  
    partition sx2 VALUES LESS THAN (3000),  
    partition sx3 VALUES LESS THAN (4000)  
);
```

Creation of Additional Databases After Installation

You can create and configure additional databases after you install Oracle Label Security.

- [About the Creation of Additional Databases After Installation](#)
When you install Oracle Database Enterprise Edition and Oracle Label Security, an initial Oracle database is created.
- [Creating Additional Databases When the Label Security Schema Is in the Seed](#)
You can configure Oracle Label Security if the database was installed with the label security schema is in the seed database.
- [Creating Additional Databases with the Custom Installation Option](#)
You can configure Oracle Label Security after a custom database installation.

About the Creation of Additional Databases After Installation

When you install Oracle Database Enterprise Edition and Oracle Label Security, an initial Oracle database is created.

If you want to create additional databases, then you should do this using the Database Configuration Assistant. Alternatively, you can create additional databases by following the steps listed in *Oracle Database Administrator's Guide*.

Each time you create a new database, you must install the Oracle Label Security data dictionary tables, views, and packages into it, and create the `LBACSYS` account.

For the first database, this is done automatically when you install Oracle Label Security, regardless of whether or not you choose the custom install. If you do not choose the custom install, then you are installing the database with the label security schema in the seed.

To create additional databases, there are different processes for configuring label security, depending on whether the first database was installed with the custom install or with the label security schema in the seed.

If you initially chose custom install, but did not install label security, you can install and configure label security using either process described in this section.

Creating Additional Databases When the Label Security Schema Is in the Seed

You can configure Oracle Label Security if the database was installed with the label security schema in the seed database.

1. Select the Oracle Label Security option in DBCA.
2. Select the check box to configure Oracle Label Security.

Creating Additional Databases with the Custom Installation Option

You can configure Oracle Label Security after a custom database installation.

1. Connect to the Oracle Database instance as user `SYS`, using the `AS SYSDBA` syntax.
2. Run the script `$ORACLE_HOME/rdbms/admin/catols.sql`.
This script installs the label-based framework, data dictionary, data types, and packages. After the script is run, the `LBACSYS` account exists, with the password `LBACSYS`. All the Oracle Label Security packages exist under this account.
3. Change the default password of the `LBACSYS` user.

Oracle Label Security Upgrades and Downgrades

You should be aware of how to manage Oracle Label Security upgrades and downgrades.

- [About Oracle Label Security Upgrades and Downgrades](#)
Oracle provides preprocess scripts that perform upgrade and downgrade operations.
- [Oracle Label Security Upgrades](#)
Oracle provides a preprocess script that you must run before you perform an upgrade.
- [Oracle Label Security Downgrades](#)
Oracle provides a preprocess script that you must run before you downgrade.

About Oracle Label Security Upgrades and Downgrades

Oracle provides preprocess scripts that perform upgrade and downgrade operations.

As a safety measure, before you run either the upgrade or downgrade preprocess script, Oracle recommends that you back up your audit records. To do this, you can archive the audit trail as described in *Oracle Database Security Guide*.

Before they run, the preprocess scripts check that there is enough space in the audit tablespace to copy all the audit records, and will exit without processing if there is not.

You may continue running your applications on the database while OLS preprocess scripts are running.

 **See Also:**

Oracle Database Upgrade Guide for requirements for upgrading databases that use Oracle Label Security and Oracle Database Vault

Oracle Label Security Upgrades

Oracle provides a preprocess script that you must run before you perform an upgrade.

- [About Oracle Label Security Upgrades](#)
You must upgrade Oracle Label Security for pre-Oracle Database 12c release 1 (12.1) databases.
- [Running the Oracle Label Security Preprocess Script Before Upgrading](#)
You can run the Oracle Label Security preprocess script before upgrading.

About Oracle Label Security Upgrades

You must upgrade Oracle Label Security for pre-Oracle Database 12c release 1 (12.1) databases.

 **Note:**

Running the `olspreupgrade.sql` script before upgrading is mandatory for upgrading databases earlier than Oracle Database 12c release (12.1) that use Oracle Label Security or Database Vault.

After you have upgraded to Oracle Database release 12c or later, you do not need to run the Oracle Label Security preprocessing script when you patch or upgrade the database.

Before performing the OLS upgrade process, you must run the Oracle Label Security preprocess upgrade script, `olspreupgrade.sql`, to process the `AUD$` table contents. The OLS upgrade moves the `AUD$` table from the `SYSTEM` schema to the `SYS` schema. The `olspreupgrade.sql` script is a preprocessing script required for this move. It creates a temporary table, `PREUPG_AUD$`, in the `SYS` schema and moves the `SYSTEM.AUD$` records to `SYS.PREUPG_AUD$`. The moved records can no longer be viewed through the `DBA_AUDIT_TRAIL` view, but can be viewed by directly accessing the `SYS.PREUPG_AUD$` table, until the upgrade completes. Once the upgrade completes, the `SYS.PREUPG_AUD$` table is permanently deleted and all audit records, can be viewed through the `DBA_AUDIT_TRAIL` view.

Running the Oracle Label Security Preprocess Script Before Upgrading

You can run the Oracle Label Security preprocess script before upgrading.

1. Copy the `ORACLE_HOME/rdbms/admin/olspreupgrade.sql` script from the newly installed Oracle home to the Oracle home of the database to be upgraded.

2. Connect to the database to be upgraded. At the system prompt, enter:

```
CONNECT SYS AS SYSDBA
Enter password password
```

3. Run the Oracle Label Security preprocess script:

```
@$ORACLE_HOME/rdbms/admin/olspreupgrade.sql
```

Note:

The upgrade status for the Oracle Label Security component will be marked `INVALID` if the Oracle Label Security preprocess script reports an error. If this happens, you must correct the errors and then rerun the upgrade process. See *Oracle Database Upgrade Guide* for more information about rerunning the upgrade process for Oracle Database.

Oracle Label Security Downgrades

Oracle provides a preprocess script that you must run before you downgrade.

- [About Oracle Label Security Downgrades](#)
You can downgrade from an Oracle Database 12c release 1 (12.1) or later database that uses Oracle Label Security or Oracle Database Vault.
- [Running the Oracle Label Security Preprocess Script Before Downgrading](#)
You must connect as `SYS` with the `SYSDBA` administrative privilege before running the Oracle Label Security preprocess script for a downgrade.

About Oracle Label Security Downgrades

You can downgrade from an Oracle Database 12c release 1 (12.1) or later database that uses Oracle Label Security or Oracle Database Vault.

To do this, you must run the OLS preprocessing script, `olspredowngrade.sql` to process the `AUD$` table contents. The OLS downgrade script moves the `AUD$` table from the `SYS` schema to the `SYSTEM` schema. The `olspredowngrade.sql` script is a processing script required in preparation for this move. It creates a temporary table, `PREDWG_AUD$`, in the `SYSTEM` schema and moves the `SYS.AUD$` records to `SYSTEM.PREDWG_AUD$`. The moved records can no longer be viewed through the `DBA_AUDIT_TRAIL` view, but you can view them by directly accessing the `SYSTEM.PREDWG_AUD$` table until the downgrade completes. Once the downgrade completes, the `SYSTEM.PREDWG_AUD$` table is permanently deleted. At this point, all audit records are available for viewing in the `DBA_AUDIT_TRAIL` data dictionary view.

Running the Oracle Label Security Preprocess Script Before Downgrading

You must connect as `SYS` with the `SYSDBA` administrative privilege before running the Oracle Label Security preprocess script for a downgrade.

1. Connect to the database to be downgraded. At the system prompt, enter:

```
CONNECT SYS AS SYSDBA  
Enter password password
```

2. Run the OLS preprocess downgrade script:

```
@$ORACLE_HOME/rdbms/admin/olspreddowngrade.sql
```

13

Releasability Using Inverse Groups

Oracle Label Security can implement the releasability using inverse groups.

- [About Inverse Groups and Releasability](#)
Inverse groups indicate *releasability* of information.
- [Comparison of Standard Groups and Inverse Groups](#)
Groups in Oracle Label Security identify organizations that own or access data.
- [How Inverse Groups Work](#)
Inverse groups are implemented in a special way and are organized to suit the needs of Oracle Label Security.
- [Algorithm for Read Access with Inverse Groups](#)
You should understand how the algorithm for read access with inverse groups works.
- [Algorithm for Write Access with Inverse Groups](#)
You should understand the algorithm for write access with inverse groups.
- [Algorithms for COMPACCESS Privilege with Inverse Groups](#)
Oracle provides algorithms for read and write access with inverse groups, for users who have `COMPACCESS` privilege.
- [Session Labels and Inverse Groups](#)
Inverse groups affect session labels and row labels.
- [Changes in Behavior of Procedures with Inverse Groups](#)
The `INVERSE_GROUP` option affects algorithms that determine the read and write access of the user to labeled data.
- [Dominance Rules for Labels with Inverse Groups](#)
You should understand how dominance rules work for Oracle labels and inverse groups.

About Inverse Groups and Releasability

Inverse groups indicate *releasability* of information.

They are used to mark the dissemination of data. When you add an inverse group to a data label, the data becomes less classified.

For example, a user with inverse groups UK and US cannot access data that only has inverse group UK. Adding US to that data makes it accessible to all users with the inverse groups UK and US.

When you assign releasabilities to a user, you mark the communication channel to the user. For data to flow across the communication channel, the data releasabilities must dominate the releasabilities assigned to the user. In other words, releasabilities assigned to a data record must contain all the releasabilities assigned to a user.

The advantage of releasabilities lies in their power to broadly disseminate information. Releasing data to the entire marketing organization becomes as simple as adding the Marketing releasability to the data record.

Comparison of Standard Groups and Inverse Groups

Groups in Oracle Label Security identify organizations that own or access data.

Like standard groups, inverse groups control the dissemination of information. However, the behavior of inverse groups differs from Oracle Label Security standard group behavior. By default, all policies created in Oracle Label Security use the standard group behavior.

The term, *releasabilities* is sometimes used to refer to the behavior provided by inverse groups. When you include inverse groups in a data label, the effect is similar to assigning label compartment authorizations to a user. When Oracle Label Security evaluates whether a user can view a row of data assigned to a label with inverse groups, it checks to see whether the data, not the user, has the appropriate group authorizations. It checks whether the data has *all* the inverse groups assigned to the user. With standard groups, by contrast, Oracle Label Security checks to see whether a user is authorized for *at least one* of the groups assigned to a row of data.

Consider a policy that contains three standard groups such as, Eastern, Western, and Southern. User1's label authorizations include the groups Eastern and Western. Assuming that User1 has been assigned the appropriate level and compartment authorizations in the policy, then:

- With standard Oracle Label Security groups, User1 can view *all* data records that have the group Eastern, or the group Western, or both Eastern and Western.
- With inverse groups, User1 can only view data records that have, *at a minimum*, *all* the groups assigned to the user, that is, both Eastern and Western. User1 *cannot* view records that have only the Eastern group, only the Western group, or that have no groups at all.

[Table 13-1](#) shows all the rows that User1 can potentially access, given the type of group that is used in the policy.

Table 13-1 Access to Standard Groups and Inverse Groups

| If row label contains groups: | User1 access with standard groups? | User1 access with inverse groups? |
|-------------------------------|------------------------------------|-----------------------------------|
| None | Y | N |
| Eastern | Y | N |
| Western | Y | N |
| Southern | N | N |
| Eastern, Western | Y | Y |
| Eastern, Southern | Y | N |
| Western, Southern | Y | N |
| Eastern, Western, Southern | Y | Y |

Standard groups indicate *ownership* of information. In this way, all data pertaining to a certain department can have that department's group in the label. When you add a

group to a data label, the data becomes more classified. For example, a user with no groups can access data that has no groups in its label. If you add the group US to the data label, the user can no longer access the data.

 **See Also:**
[Group Components](#)

How Inverse Groups Work

Inverse groups are implemented in a special way and are organized to suit the needs of Oracle Label Security.

- [Implementation of Inverse Groups with INVERSE_GROUP Enforcement](#)
When creating an Oracle Label Security policy, you can specify whether the policy can use inverse group functionality to implement releasability.
- [Inverse Groups and Label Components](#)
An Oracle Label Security policy created with the inverse group option uses the same policy label components as standard groups.
- [Computed Labels with Inverse Groups](#)
Inverse groups affect computed label values.
- [Inverse Groups and Hierarchical Structure](#)
Standard groups in Oracle Label Security are hierarchical, so that a group can be associated with a parent group.
- [Inverse Groups and User Privileges](#)
With inverse groups implemented, the meaning of user privileges remains the same.

Implementation of Inverse Groups with INVERSE_GROUP Enforcement

When creating an Oracle Label Security policy, you can specify whether the policy can use inverse group functionality to implement releasability.

To do this, you must specify `INVERSE_GROUP` as one of the `default_options` in the `CREATE_POLICY` statement.

The `INVERSE_GROUP` option can be set only at policy creation time. Once a policy is created, this option cannot be changed.

The `INVERSE_GROUP` option is thus policywide. It cannot be turned on or off when the policy is applied to a table or schema. If you attempt to do so, using the procedure `APPLY_TABLE_POLICY` or `APPLY_SCHEMA_POLICY`, then an error will be generated.

While other policy enforcement options can be dropped from a policy, the `INVERSE_GROUP` policy configuration option cannot be dropped once it is set. To remove the option, you must drop and then re-create the policy.

You can give individual users authorization for one or more inverse groups.

Inverse Groups and Label Components

An Oracle Label Security policy created with the inverse group option uses the same policy label components as standard groups.

These components include levels, compartments, and groups.

With inverse groups, however, the user's read groups and write groups have a different meaning and role in data access.

Consider the following policy example, with three levels, one compartment, and three groups:

Table 13-2 Policy Example

| Policy Component | Abbreviation |
|------------------|--------------|
| Levels: | - |
| UNCLASSIFIED | UN |
| CONFIDENTIAL | CON |
| SECRET | SE |
| Compartments: | - |
| FINANCIAL | FIN |
| Groups: | - |
| EASTERN | EAS |
| WESTERN | WES |
| SOUTHERN | SOU |

Two user labels have been assigned, `CON:FIN` and `SE:FIN:EAS,WES`

Two data labels have been assigned, `CON:FIN:EAS` and `SE:FIN:EAS`

User access to the data differs, depending on the type of group being used:

- If the policy uses standard groups, then:
 - The user with the label `CON:FIN` *cannot* read `CON:FIN:EAS` data.
 - The user with the label `SE:FIN:EAS,WES` *can* read `SE:FIN:EAS` data.
- If the policy has the `INVERSE GROUPS` policy enforcement option, then:
 - The user with the label `CON:FIN` *can* read `CON:FIN:EAS` data.
 - The user with the label `SE:FIN:EAS,WES` *cannot* read `SE:FIN:EAS` data.

Computed Labels with Inverse Groups

Inverse groups affect computed label values.

- [Computed Session Labels with Inverse Groups](#)
After the administrator assigns label authorizations to a user, Oracle Label Security automatically computes a number of labels.
- [Inverse Groups and Computed Max Read Groups and Max Write Groups](#)
Oracle Label Security provides different inverse groups to handle read and write operations.

Computed Session Labels with Inverse Groups

After the administrator assigns label authorizations to a user, Oracle Label Security automatically computes a number of labels.

With inverse groups, these labels are as follows:

Table 13-3 Computed Session Labels with Inverse Groups

| Computed Label | Definition |
|---------------------|---|
| Max Read Label | The user's maximum level combined with his or her authorized compartments and the minimum set of inverse groups that should be in the user label (session label) |
| Max Write Label | The user's maximum level combined with the compartments for which the user has been granted write access. Contains the maximum authorized inverse groups that can be set in any label. The user has write authorizations on all these inverse groups. |
| Min Write Label | The user's minimum level. |
| Default Read Label | The default level, combined with compartments and inverse groups that have been designated as default for the user. |
| Default Write Label | A subset of the default read label, containing the compartments and inverse groups for which the user has been granted write access. However the inverse groups component has no significance as it is the Max Write Groups that is always used for write access. |
| Default Row Label | The combination of components between the user's minimum write label and the maximum write label, which has been designated as the default for the data label for inserted data. The Inverse groups should be a superset of inverse groups in the default label and a subset of Max Write Groups. |

Related Topics

- [Computed Session Labels](#)
Oracle Label Security automatically computes a number of labels based on the value of the session label.

Inverse Groups and Computed Max Read Groups and Max Write Groups

Oracle Label Security provides different inverse groups to handle read and write operations.

From the computed values in [Table 13-3](#), two sets of groups are identified for label evaluation of read and write access.

Table 13-4 Sets of Groups for Evaluating Read and Write Access

| Sets of Groups | Meaning |
|------------------|--|
| Max Read Groups | Max Read Groups are the groups contained in the Max Read Label, identifying the <i>minimum</i> set of inverse groups that can be set in any user label. |
| Max Write Groups | Max Write Groups are the groups contained in the Max Write Label, identifying the <i>maximum</i> authorized inverse groups that can be set in any user label. This set of groups is checked at the time of write access, and also when setting session labels. Note that Max Write Groups is a superset of Max Read Groups. |

As shown in [Table 13-5](#), for standard groups you can have `READ ONLY` and `READ/WRITE` authorizations; for inverse groups you can have `WRITE ONLY` and `READ/WRITE` authorizations.

Table 13-5 Read and Write Authorizations for Standard Groups and Inverse Groups

| Type of Group | READ ONLY | READ/WRITE | WRITE ONLY |
|-----------------|--|--|--|
| Standard Groups | The group is present only in Max Read Label, not in Max Write Label. | The group is present in both Max Read Label and Max Write Label. | Not supported |
| Inverse Groups | Not supported | The group is present in both Max Read Label and Max Write Label. | The group is present only in Max Write Label, not in Max Read Label. |

Although Max Read Groups identifies the set of groups contained in the Max Read Label, this value represents the *minimum* set of inverse groups that can be set. For example:

Max Read Groups: `S:C1:G1,G2`

Max Write Groups: `S:C1:G1,G2,G3,G4,G5`

Here, the user can read data that contains at least the two groups listed in Max Read Groups.

Note that in standard groups, there can never be a situation in which there are more groups in the Max Write Label than in the Max Read Label.

Inverse Groups and Hierarchical Structure

Standard groups in Oracle Label Security are hierarchical, so that a group can be associated with a parent group.

For example, the `EASTERN` region can be the parent of two subordinate groups: `EAS_SALES`, and `EAS_HR`.

In a policy with standard groups, if the user label has the parent group, then it can access all data of the subordinate groups.

With inverse groups, parent-child relationships are not supported.

Inverse Groups and User Privileges

With inverse groups implemented, the meaning of user privileges remains the same.

When the user has no special privileges, then the read algorithm and the write algorithm are different for standard groups and inverse groups. The differences are described later, in [Algorithm for Read Access with Inverse Groups](#) and [Algorithm for Write Access with Inverse Groups](#).

The effect of inverse groups on the COMPACCESS privilege is described later, in [Algorithms for COMPACCESS Privilege with Inverse Groups](#).

Inverse groups have no impact upon the following user privileges:

- PROFILE_ACCESS
- WRITEUP
- WRITEDOWN
- WRITEACROSS

Algorithm for Read Access with Inverse Groups

You should understand how the algorithm for read access with inverse groups works.

To read data in a table with the `INVERSE GROUP` option in effect, the label evaluation process proceeds from levels to groups to compartments, as illustrated in [Figure 13-1](#). (Note that the current session label is the label being evaluated.)

1. The user's level must be greater than or equal to the level of data.
2. The user's label must include all the compartments assigned to the data
3. The groups in the data label must be a superset of the groups in the user label.

If the user's label passes these tests, then the user can access the data. If not, the user is denied access. Note that if the data label is null or invalid, then the user is denied access.

 **Note:**

This flow diagram is true only when the user has no special privileges.

Figure 13-1 Read Access Label Evaluation with Inverse Groups

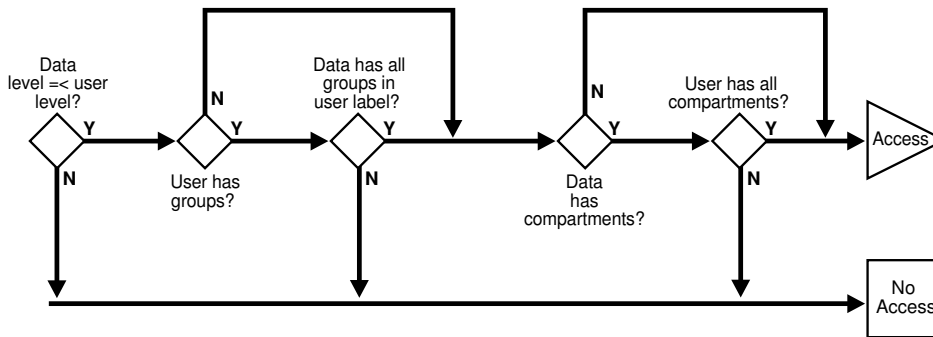

Related Topics

- [How Oracle Label Security Algorithm for Read Access Works](#)
The `READ_CONTROL` enforcement determines the ability to read data in a row.

Algorithm for Write Access with Inverse Groups

You should understand the algorithm for write access with inverse groups.

To write data in a table with the `INVERSE GROUP` option, the label evaluation process proceeds from levels to groups to compartments, as illustrated in [Figure 13-2](#). (Note that the current session label is the label being evaluated.)

1. The level in the data label must be greater than or equal to the user's minimum level, and less than or equal to the user's session level.
2. One of the following conditions must be met:
The groups in the data label must be a superset of the groups in the user label.
or
The user has `READ` access privilege on the policy.
3. The user's Max Write Groups must be a superset of the data label groups.
4. The user label must have write access on all of the compartments in the data label.

Note that if the data label is null or invalid, then the user is denied access.



Note:

This flow diagram is true only when the user has no special privileges.

Figure 13-2 Write Access Label Evaluation with Inverse Groups

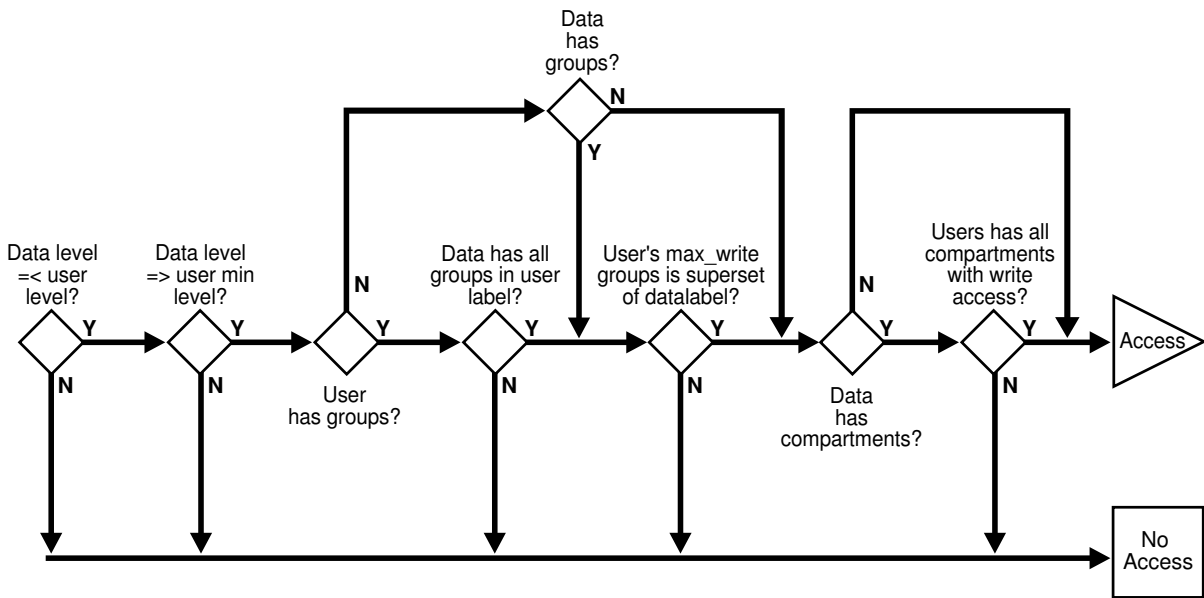

 **See Also:**
[How the Oracle Label Security Algorithm for Write Access Works](#)

Algorithms for COMPACCESS Privilege with Inverse Groups

Oracle provides algorithms for read and write access with inverse groups, for users who have `COMPACCESS` privilege.

The `COMPACCESS` privilege allows a user to access data based on the row's compartments, independent of the row's groups.

- When compartments exist and access to them is authorized, then the group authorization is bypassed.
- If a row has no compartments, then access is determined by the inverse group authorizations.

Figure 13-3 and Figure 13-4 show the label evaluation process for read access and write access for a user with the `COMPACCESS` privilege. If the data label is null or invalid, then the user is denied access.

(Note that the current session label is the label being evaluated.)

Figure 13-3 Read Access Label Evaluation: COMPACCESS Privilege and Inverse Groups

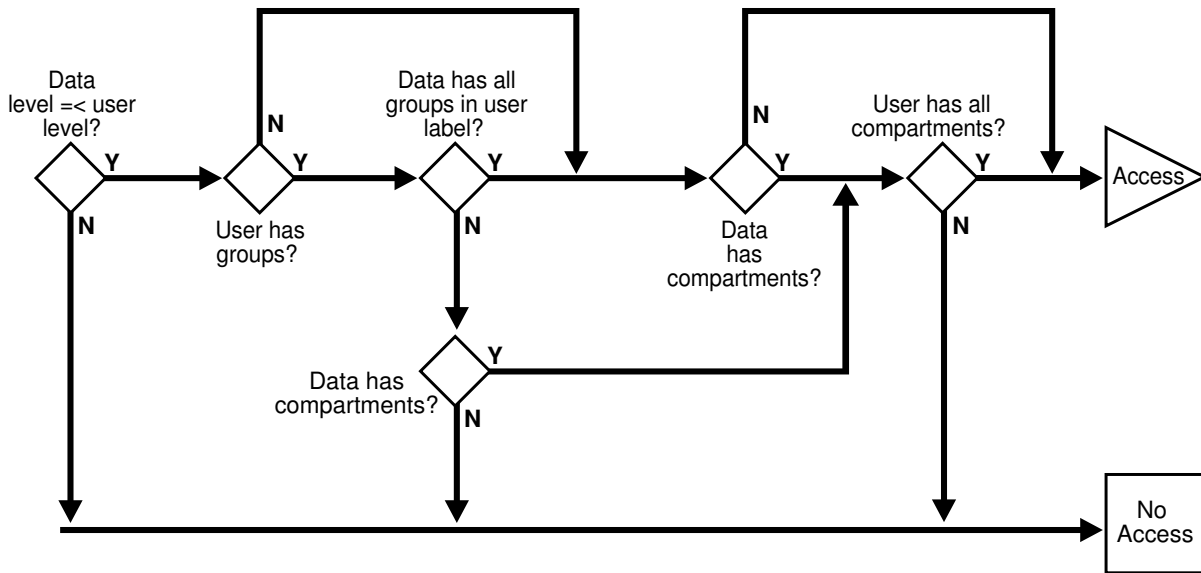
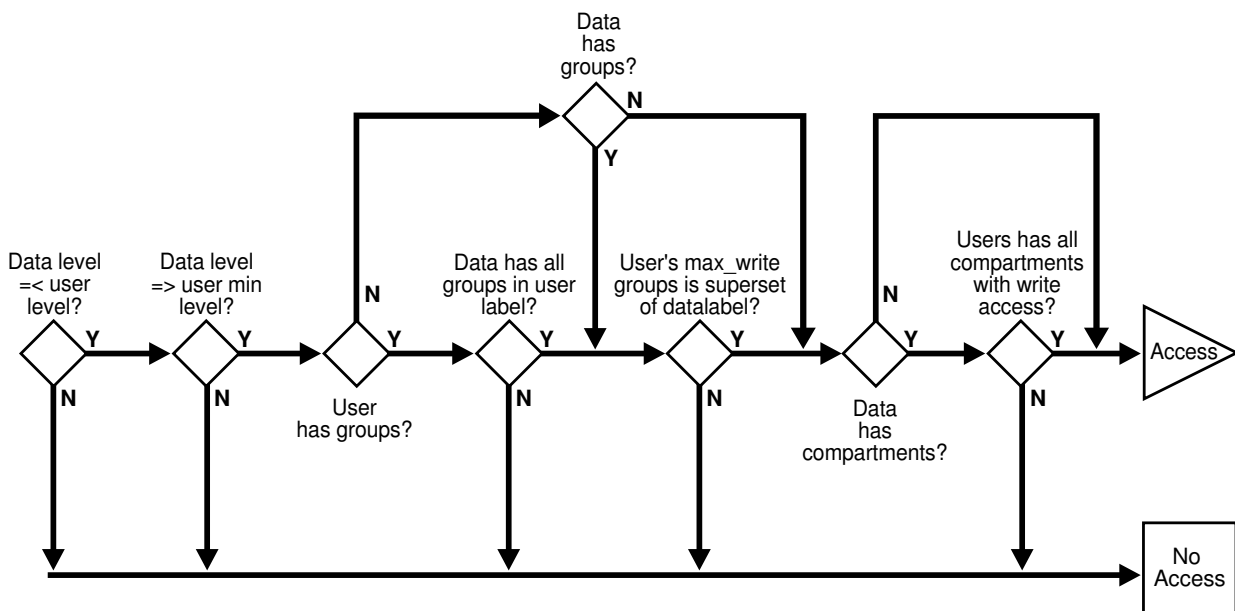

Figure 13-4 Write Access Label Evaluation: COMPACCESS Privilege and Inverse Groups



Session Labels and Inverse Groups

Inverse groups affect session labels and row labels.

- [Initial Session and Row Labels for Standard or Inverse Groups](#)
Oracle provides initial session and row labels for standard and inverse groups.
- [Setting Current Session or Row Labels for Standard or Inverse Groups](#)
You can set the current session or row labels for standard or inverse groups.

- [Examples of Session Labels and Inverse Groups](#)
Oracle provides examples of using inverse groups.

Initial Session and Row Labels for Standard or Inverse Groups

Oracle provides initial session and row labels for standard and inverse groups.

- [About the Initial Session and Row Labels for Standard or Inverse Groups](#)
The use of inverse groups affects the behavior of Oracle Label Security procedures that determine the session label.
- [Standard Groups: Rules for Changing Initial Session/Row Labels](#)
A user's default session label can be changed using `SA_USER_ADMIN.SET_DEFAULT_LABEL`.
- [Inverse Groups: Rules for Changing Initial Session/Row Labels](#)
The default session label can include groups in the authorized list if the new write label dominates the current default row label.

About the Initial Session and Row Labels for Standard or Inverse Groups

The use of inverse groups affects the behavior of Oracle Label Security procedures that determine the session label.

The `SA_USER_ADMIN.SET_DEFAULT_LABEL` and `SA_USER_ADMIN.SET_ROW_LABEL` procedures set the user's initial session label and row label, respectively, to the one specified.

Standard Groups: Rules for Changing Initial Session/Row Labels

A user's default session label can be changed using `SA_USER_ADMIN.SET_DEFAULT_LABEL`.

In the case of standard groups, the default session label can be set to include any groups in the authorized list, as long as the current default row label will still be dominated by the new write label. That is, the row label will have *the same or fewer standard groups* than the new write label.

The same rule applies for `SA_USER_ADMIN.SET_ROW_LABEL`.

Inverse Groups: Rules for Changing Initial Session/Row Labels

The default session label can include groups in the authorized list if the new write label dominates the current default row label.

That is, the row label will have *the same or more inverse groups* than the new write label. The same rule applies for `SA_USER_ADMIN.SET_ROW_LABEL`.

Related Topics

- [SA_USER_ADMIN.SET_DEFAULT_LABEL](#)
The `SA_USER_ADMIN.SET_DEFAULT_LABEL` procedure sets the user's initial session label to the one specified.
- [SA_USER_ADMIN.SET_ROW_LABEL](#)
The `SA_USER_ADMIN.SET_ROW_LABEL` procedure sets a user's initial row label to the one specified.

- [Dominance Rules for Labels with Inverse Groups](#)
You should understand how dominance rules work for Oracle labels and inverse groups.

Setting Current Session or Row Labels for Standard or Inverse Groups

You can set the current session or row labels for standard or inverse groups.

- [About Setting Current Session or Row Labels for Standard or Inverse Groups](#)
The use of inverse groups affects the behavior of the `SA_SESSION.SET_LABEL` and `SA_SESSION.SET_ROW_LABEL` procedures.
- [Standard Groups: Rules for Changing Current Session/Row Labels](#)
With standard groups, the `SA_SESSION.SET_LABEL` procedure can set the session label to include groups in the user's authorized group list.
- [Inverse Groups: Rules for Changing Current Session/Row Labels](#)
With inverse groups, the addition of groups to the session label *decreases* a user's ability to access sensitive data with fewer groups.

About Setting Current Session or Row Labels for Standard or Inverse Groups

The use of inverse groups affects the behavior of the `SA_SESSION.SET_LABEL` and `SA_SESSION.SET_ROW_LABEL` procedures.

These procedures can be used to set the user's current session label and row label, respectively.

Standard Groups: Rules for Changing Current Session/Row Labels

With standard groups, the `SA_SESSION.SET_LABEL` procedure can set the session label to include groups in the user's authorized group list.

Subgroups of authorized groups are implicitly included in the authorized list.

Note that if you change the session label, then this may affect the value of the session's row label.

Use the `SET_ROW_LABEL` procedure to set the row label value for the current database session. The compartments and groups in the label must be a subset of compartments and groups in the session label to which the user has write access.

Inverse Groups: Rules for Changing Current Session/Row Labels

With inverse groups, the addition of groups to the session label *decreases* a user's ability to access sensitive data with fewer groups.

The removal of groups enables the user to access *more* sensitive information. So, the user should be allowed to add groups to the session label, as long as Max Read Groups is a subset of the groups in the session label, and Max Write Groups is a superset of groups in the session label. The same restriction applies when a user removes groups from the session label.

Note that there are no subgroups of authorized groups when using inverse groups. This is because parent groups are not allowed in policies using inverse groups.

Use the `SET_ROW_LABEL` procedure to set the row label value for the current database session. The compartments in the label must be a subset of compartments in the session label to which the user has write access.

The user is allowed to add inverse groups to the row label, as long as the session label inverse groups are a subset of the row label inverse groups, and Max Write Groups is a superset of inverse groups in the row label.

For example:

- If the user has the inverse groups UK and US as his Max Read Groups, and UK,US,CAN as his Max Write Groups. The user can set his session label to `C:ALPHA:UK,US,CAN` but not to `C:ALPHA:UK`.
- If the user has the inverse group UK as his Max Read Groups, and UK,CAN as his Max Write Groups.assigned to him. The user can set the session label to `C:ALPHA:UK,CAN` but cannot change it to either `C:ALPHA` or `C:ALPHA:UK,US,CAN`.

Related Topics

- [SA_SESSION.SET_LABEL](#)
The `SA_SESSION.SET_LABEL` procedure sets the label of the current database session.
- [SA_SESSION.SET_ROW_LABEL](#)
The `SA_SESSION.SET_ROW_LABEL` procedure sets the default row label value for the current database session.

Examples of Session Labels and Inverse Groups

Oracle provides examples of using inverse groups.

- [Example: Simple Inverse Groups](#)
You can create a simple policy that implements inverse groups with a set of special labels.
- [Example: Complex Inverse Groups](#)
You can create a more complex policy that implements inverse groups with a set of special labels.

Example: Simple Inverse Groups

You can create a simple policy that implements inverse groups with a set of special labels.

Table 13-6 Labels for Inverse Groups Example 1

| Name | Definition |
|--|---------------------|
| Max Read Label | SE:ALPHA,BETA:G1,G2 |
| Max Write Label | SE:ALPHA:G1,G2,G3 |
| Default Read Label | SE:ALPHA,BETA:G1,G2 |
| Default Write Label | SE:ALPHA:G1,G2 |
| Default Row Label | SE:ALPHA:G1,G2 |
| From which the following values are derived: | - |

Table 13-6 (Cont.) Labels for Inverse Groups Example 1

| Name | Definition |
|------------------|------------|
| Max Read Groups | G1,G2 |
| Max Write Groups | G1,G2,G3 |

The following conclusions can be drawn:

- User01 can update data with label SE:ALPHA:G1,G2 as well as data with label SE:ALPHA:G1,G2,G3. User1 *cannot*, however, update label SE:ALPHA:G1.
If standard groups were being used, rather than inverse groups, then User1 could update data with label SE:ALPHA:G1.
- Data that User01 inserts has the label SE:ALPHA:G1,G2. (This is the same as with standard groups.)
- If User01 leaves the default label as is, and sets the row label to SE:ALPHA:G1,G2,G3, then user1 will insert SE:ALPHA:G1,G2,G3 in new rows of data that is written. (In standard groups, User1 can never set more groups in the row label than in the default label.)

Example: Complex Inverse Groups

You can create a more complex policy that implements inverse groups with a set of special labels.

Table 13-7 Labels for Inverse Groups Example 2

| Name | Definition |
|--|------------------|
| Max Read Label | C:ALPHA: |
| Max Write Label | C:ALPHA:G1,G2,G3 |
| Default Read Label | C:ALPHA: |
| Default Write Label | C:ALPHA: |
| Default Row Label | C:ALPHA: |
| From which the following values are derived: | - |
| Max Read Groups | (an empty set) |
| Max Write Groups | G1,G2,G3 |

The following conclusions can be drawn:

- User01 can update any data with level C, compartment ALPHA, and any combination of groups G1, G2, G3, or no groups. User01 inserts the label C:ALPHA: in new data that User01 writes.
- User02, who has Max Read Groups of G1,G2 or G1,G3, and so on, will not be able to view the data written by User01. This is because User01's Default Row Label contains no groups.

- `User01` can choose to set inverse groups in the row label, as long as the inverse groups in the session label dominates the row label (that is, `User01`'s session label contains the same or fewer groups than contained in the row label).

This is true because the row label must have at least the groups in the session label, and can at most have the Maximum Write Groups. If the session label is `G1`, then you can set the groups in the row label from `G1` to the Max Write Groups (`G1,G2,G3`).

- If `User01` sets his session label and row label to `C:ALPHA:G1:G2:G3`, then his data becomes accessible to anyone who has any combination of `G1,G2,G3` in his Max Read Groups.

Changes in Behavior of Procedures with Inverse Groups

The `INVERSE_GROUP` option affects algorithms that determine the read and write access of the user to labeled data.

- [SA_SYSDBA.CREATE_POLICY with Inverse Groups](#)
The `SA_SYSDBA.CREATE_POLICY` procedure creates the policy, defines an optional policy-specific column name, and specifies policy options.
- [SA_SYSDBA.ALTER_POLICY with Inverse Groups](#)
The `SA_SYSDBA.ALTER_POLICY` procedure changes a policy's default enforcement options, except for the `INVERSE_GROUP` option.
- [SA_USER_ADMIN.ADD_GROUPS with Inverse Groups](#)
The `SA_USER_ADMIN.ADD_GROUPS` procedure adds groups to a user, indicating whether the groups are authorized for write as well as read.
- [SA_USER_ADMIN.ALTER_GROUPS with Inverse Groups](#)
The `SA_USER_ADMIN.ALTER_GROUPS` procedure changes the write access, default label indicator, and row label indicator for each group.
- [SA_USER_ADMIN.SET_GROUPS with Inverse Groups](#)
The `SA_USER_ADMIN.SET_GROUPS` procedure assigns groups to a user and identifies default values for the user's session label and row label.
- [SA_USER_ADMIN.SET_USER_LABELS with Inverse Groups](#)
The `SA_USER_ADMIN.SET_USER_LABELS` procedure sets the user's levels, compartments, and groups using a set of labels, instead of the individual components.
- [SA_USER_ADMIN.SET_DEFAULT_LABEL with Inverse Groups](#)
The `SA_USER_ADMIN.SET_DEFAULT_LABEL` procedure sets the user's initial session label.
- [SA_USER_ADMIN.SET_ROW_LABEL with Inverse Groups](#)
The `SA_USER_ADMIN.SET_ROW_LABEL` procedure sets the user's initial row label.
- [SA_COMPONENTS.CREATE_GROUP with Inverse Groups](#)
The `SA_COMPONENTS.CREATE_GROUP` procedure create a group, including its short name and long name, and optionally a parent group.
- [SA_COMPONENTS.ALTER_GROUP_PARENT with Inverse Groups](#)
The `SA_COMPONENTS.ALTER_GROUP_PARENT` function is disabled for policies with the inverse group option.
- [SA_SESSION.SET_LABEL with Inverse Groups](#)
The `SA_SESSION.SET_LABEL` procedure sets the label of the current database session.

- [SA_SESSION.SET_ROW_LABEL with Inverse Groups](#)
The `SET_ROW_LABEL` procedure sets the default row label value for the current database session.
- [LEAST_UBOUND with Inverse Groups](#)
The `LEAST_UBOUND` (`LUBD`) function returns a character string label that is the least upper bound of `label1` and `label2`.
- [GREATEST_LBOUND with Inverse Groups](#)
The `GREATEST_LBOUND` (`GLBD`) function determines the lowest label of the data that can be involved in an operation, given two different labels.

SA_SYSDBA.CREATE_POLICY with Inverse Groups

The `SA_SYSDBA.CREATE_POLICY` procedure creates the policy, defines an optional policy-specific column name, and specifies policy options.

With inverse group support the, user has one more policy enforcement option, `INVERSE_GROUP`. For example:

```
PROCEDURE CREATE_POLICY (
  HR IN VARCHAR2,
  SA_LABEL IN VARCHAR2 DEFAULT NULL,
  INVERSE_GROUP IN VARCHAR2 DEFAULT NULL);
```

Related Topics

- [SA_SYSDBA.CREATE_POLICY](#)
The `SA_SYSDBA.CREATE_POLICY` procedure creates a new Oracle Label Security policy, defines a policy-specific column name, and specifies default policy options.

SA_SYSDBA.ALTER_POLICY with Inverse Groups

The `SA_SYSDBA.ALTER_POLICY` procedure changes a policy's default enforcement options, except for the `INVERSE_GROUP` option.

Once a policy is configured for inverse groups, it cannot be changed. You can also change the column names associated with an OLS policy.

Related Topics

- [SA_SYSDBA.ALTER_POLICY](#)
The `SA_SYSDBA.ALTER_POLICY` procedure sets and modifies column names that are associated with the policy.

SA_USER_ADMIN.ADD_GROUPS with Inverse Groups

The `SA_USER_ADMIN.ADD_GROUPS` procedure adds groups to a user, indicating whether the groups are authorized for write as well as read.

The type of access authorized depends on the `access_mode` parameter.

Table 13-8 Access Authorized by Values of `access_mode` Parameter

| Access_Mode Parameter | Meaning |
|-------------------------|---|
| <code>READ_WRITE</code> | Indicates that write is authorized. (That is, the group is contained in both Max Read Groups and Max Write Groups.) |

Table 13-8 (Cont.) Access Authorized by Values of access_mode Parameter

| Access_Mode Parameter | Meaning |
|-----------------------|---|
| WRITE_ONLY | Indicates that the group is contained in Max Write Groups and not in Max Read Groups |
| access_mode | If access_mode is set to READ_WRITE, then the group is added to both Max Read Groups and Max Write Groups. If access_mode is set to SA_UTL.WRITE_ONLY, then the group is added only to the Max Write Groups. If access_mode is NULL, then it is set to SA_UTL.READ_WRITE. |
| in_def | Specifies whether these groups should be in the default groups (Y/N). If in_def is NULL, then it will be set to Y or N as follows: If access mode is READ_WRITE, in_def is set to Y. If access mode is WRITE_ONLY, in_def is set to N. |
| in_row | Specifies whether these groups should be in the row label (Y/N), using the identical criteria as for in_def. However, if in_def is Y, then in_row must also be Y. |

Note that if `in_def` is Y in a row, then `in_row` must also be set to Y, but not the other way round.

The same is the case with the `in_row` field.

See Also:

- Syntax for [SA_USER_ADMIN.ADD_GROUPS](#)
- [Inverse Groups and Computed Max Read Groups and Max Write Groups](#)

SA_USER_ADMIN.ALTER_GROUPS with Inverse Groups

The `SA_USER_ADMIN.ALTER_GROUPS` procedure changes the write access, default label indicator, and row label indicator for each group.

The behavior of inverse groups is the same as described in the case of `ADD_GROUPS`.

See Also:

Syntax for [SA_USER_ADMIN.ALTER_GROUPS](#)

SA_USER_ADMIN.SET_GROUPS with Inverse Groups

The `SA_USER_ADMIN.SET_GROUPS` procedure assigns groups to a user and identifies default values for the user's session label and row label.

Inverse groups are handled differently than standard groups, as follows:

Table 13-9 Assigning Groups to a User

| Group Set Name | Meaning |
|----------------|--|
| read_groups | A comma-delimited list of groups that would be Max Read Groups |
| write_groups | A comma-delimited list of groups that would be Max Write Groups. It must be a superset of read_groups. If write_groups is NULL, then they are set to read_groups. |
| def_groups | Specifies the default groups. It should at least have read_groups, and write_groups should be a superset of def_groups. If def_groups is NULL, then they are set to the read_groups. |
| row_groups | Specifies the row groups. It should at least have the def_groups and should be a subset of max write groups. If row_groups is NULL, then they are set to the def_groups, because for inverse groups, all def_groups are also in write_groups. |



See Also:

Syntax for [SA_USER_ADMIN.SET_GROUPS](#)

SA_USER_ADMIN.SET_USER_LABELS with Inverse Groups

The SA_USER_ADMIN.SET_USER_LABELS procedure sets the user's levels, compartments, and groups using a set of labels, instead of the individual components.

Inverse groups are handled differently than standard groups, as follows:

Table 13-10 Inverse Group Label Definitions

| Name | Definition |
|-----------------|--|
| max_read_label | Specifies the label string to be used to initialize the user's maximum authorized read label. Composed of the user's maximum level, compartments authorized for read access, and if inverse groups, minimum set of groups that can be set in any label.(Max Read Groups) |
| max_write_label | Specifies the label string to be used to initialize the user's maximum authorized write label. Composed of the user's maximum level, compartments authorized for write access, and if inverse groups, the maximum authorized groups that can be set in any label (Max Write Groups). All the inverse groups in this have write authorization also. It should be a superset of groups in max_read_label. If max_write_label is not specified, then it is set to max_read_label. |

Table 13-10 (Cont.) Inverse Group Label Definitions

| Name | Definition |
|------------------------|--|
| <code>def_label</code> | Specifies the label string to be used to initialize the user's session label, including level, compartments, and groups (a subset of <code>max_read_label</code>). If <code>default_label</code> is not specified, then it is set to <code>max_read_label</code> . For inverse groups, component it should at least have the groups in <code>max_read_label</code> , and groups in <code>max_write_label</code> should be a superset of the groups in the <code>def_label</code> . |
| <code>row_label</code> | Specifies the label string to be used to initialize the program's row label. Includes levels, compartments, and groups: subsets of <code>max_write_label</code> and <code>def_label</code> . If <code>row_label</code> is not specified, then it is set to <code>def_label</code> , with only the compartments and groups authorized for write access. The inverse groups component is set to the same as that in <code>def_label</code> if the <code>row_label</code> is not specified. The inverse groups in row label should at least be those in default label and should be a subset of Max Write Groups. |

**See Also:**Syntax for [SA_USER_ADMIN.SET_USER_LABELS](#)

SA_USER_ADMIN.SET_DEFAULT_LABEL with Inverse Groups

The `SA_USER_ADMIN.SET_DEFAULT_LABEL` procedure sets the user's initial session label.

All the rules mentioned for setting inverse groups component of session label mentioned in [Session Labels and Inverse Groups](#) are applicable here.

**See Also:**Syntax for [SA_USER_ADMIN.SET_DEFAULT_LABEL](#)

SA_USER_ADMIN.SET_ROW_LABEL with Inverse Groups

The `SA_USER_ADMIN.SET_ROW_LABEL` procedure sets the user's initial row label.

When specifying the `row_label`, the inverse groups component must contain at least all the inverse groups in `def_label` and should be a subset of Max Write Groups.

**See Also:**

- Syntax for [SA_USER_ADMIN.SET_ROW_LABEL](#)
- [Initial Session and Row Labels for Standard or Inverse Groups](#)

SA_COMPONENTS.CREATE_GROUP with Inverse Groups

The `SA_COMPONENTS.CREATE_GROUP` procedure create a group, including its short name and long name, and optionally a parent group.

With inverse groups, the `parent_name` field should always be `NULL`. If the user specifies a value for this field, then an error message is displayed, indicating that the group hierarchy is disabled.



See Also:

Syntax for [SA_COMPONENTS.CREATE_GROUP](#)

SA_COMPONENTS.ALTER_GROUP_PARENT with Inverse Groups

The `SA_COMPONENTS.ALTER_GROUP_PARENT` function is disabled for policies with the inverse group option.

An error message is displayed if the user calls this function.



See Also:

Syntax for [SA_COMPONENTS.ALTER_GROUP](#)

SA_SESSION.SET_LABEL with Inverse Groups

The `SA_SESSION.SET_LABEL` procedure sets the label of the current database session.

For the current user, this procedure follows the same rules for setting the session label as does the `SA_USER_ADMIN.SET_USER_LABEL` function.



See Also:

- Syntax for [SA_SESSION.SET_LABEL](#).
- [Setting Current Session or Row Labels for Standard or Inverse Groups](#)

SA_SESSION.SET_ROW_LABEL with Inverse Groups

The `SET_ROW_LABEL` procedure sets the default row label value for the current database session.

For the current user, this procedure follows the same rules for setting the row label as does the `sa_user_admin.set_row_label` function.

 **See Also:**

- Syntax for [SA_SESSION.SET_ROW_LABEL](#)
- [Initial Session and Row Labels for Standard or Inverse Groups](#)

LEAST_UBOUND with Inverse Groups

The `LEAST_UBOUND` (`LUBD`) function returns a character string label that is the least upper bound of `label1` and `label2`.

With *standard* groups, the least upper bound is the highest level, the union of the compartments in the labels, and *the union of the groups* in the labels.

With *inverse* groups, the least upper bound is the highest level, the union of the compartments in the labels, and *the intersection of the inverse groups* in the labels.

For example, with inverse groups, the least upper bound of `HIGHLY_SENSITIVE:ALPHA:G1,G2` and `SENSITIVE:BETA:G1` is `HIGHLY_SENSITIVE:ALPHA,BETA:G1`.

GREATEST_LBOUND with Inverse Groups

The `GREATEST_LBOUND` (`GLBD`) function determines the lowest label of the data that can be involved in an operation, given two different labels.

This function returns a character string label that is the greatest lower bound of `label1` and `label2`.

With *standard* groups, the greatest lower bound is the lowest level, and the *intersection of the compartments in the labels and the groups* in the labels.

With *inverse* groups, the greatest lower bound is the lowest level, and the *intersection of the compartments in the labels and the union of inverse groups* in the labels.

For example, with inverse groups the greatest lower bound of `HIGHLY_SENSITIVE:ALPHA:G1,G3` and `SENSITIVE::G1` is `SENSITIVE:G1,G3`

Related Topics

- [Determination of the Upper and Lower Bounds of Labels](#)
Oracle Label Security provides functions that determine the least upper bound or the greatest lower bound of two or more labels.

Dominance Rules for Labels with Inverse Groups

You should understand how dominance rules work for Oracle labels and inverse groups.

Dominance rules for Oracle Label Security with standard groups can be summarized as follows:

A user label dominates a data label if:

- User level is greater than or equal to the data level

- User compartments are a superset of the data compartments
- User groups intersects (have at least one group from) the data groups

Dominance rules for Oracle Label Security with inverse groups can be summarized as follows:

A user label dominates a data label if:

- User level is greater than or equal to the data level
- User compartments are a superset of the data compartments
- Data groups are a superset of user groups

Related Topics

- [About Dominant and Dominated Labels](#)
The relationship between two labels can be described in terms of *dominance*.

Part IV

Appendixes

Part IV contains reference material for using Oracle Label Security.

- [Disabling and Enabling Oracle Label Security](#)
You can disable and enable Oracle Label Security as necessary.
- [Advanced Topics in Oracle Label Security](#)
Oracle provides advanced functionality for Oracle Label Security, such as the ability to analyze relationships between labels.
- [Command-line Tools for Label Security Using Oracle Internet Directory](#)
Oracle Label Security provides command-line tools for using Oracle Internet Directory.
- [Oracle Label Security in an Oracle RAC Environment](#)
You can use Oracle Label Security in an Oracle Real Application Clusters (Oracle RAC) environment.
- [Oracle Label Security PL/SQL Packages](#)
Oracle Label Security provides a set of PL/SQL packages.
- [Oracle Label Security Reference](#)
Oracle Label Security provides data dictionary tables and views. You should also be aware of Oracle Label Security restrictions.
- [Frequently Asked Questions about Oracle Label Security](#)
Customers have frequently asked questions about Oracle Label Security.

A

Disabling and Enabling Oracle Label Security

You can disable and enable Oracle Label Security as necessary.

Note:

Oracle does not support the deinstallation of Oracle Label Security.

- [When You Must Disable Oracle Label Security](#)
You may need to disable Oracle Label Security to perform upgrade tasks or correct erroneous configurations.
- [Disabling Oracle Label Security](#)
If Oracle Database Vault has been enabled, then do not disable Oracle Label Security.
- [Enabling Oracle Label Security](#)
You can enable Oracle Label Security in SQL*Plus.

When You Must Disable Oracle Label Security

You may need to disable Oracle Label Security to perform upgrade tasks or correct erroneous configurations.

Another reason for disabling Oracle Label Security is if you want to test an application without enforcing Oracle Label Security. You can reenable Oracle Label Security after you complete the tasks.

Related Topics

- [Checking if Oracle Label Security Has Been Registered and Enabled](#)
You can query the `DBA_OLS_STATUS` and `CDB_OLS_STATUS` data dictionary views to find if Oracle Label Security has already been registered and enabled.

Disabling Oracle Label Security

If Oracle Database Vault has been enabled, then do not disable Oracle Label Security.

See *Oracle Database Vault Administrator's Guide* to find if Database Vault has been enabled.

To disable Oracle Label Security:

1. Log into the database instance as user `sys` or a user who has been granted the `LBAC_DBA` role.

For example:

```
sqlplus psmith_ols -- Or, psmith_ols@hrpdb for the hrpdb pluggable database (PDB)  
Enter password: password
```

2. Run the following procedure:

```
EXEC LBACSYS.OLS_ENFORCEMENT.DISABLE_OLS;
```

3. Restart the database.

For example:

```
CONNECT SYS AS SYSOPER  
Enter password: password
```

```
SHUTDOWN IMMEDIATE  
STARTUP
```

4. For Oracle Real Application Cluster (Oracle RAC) environment or a multitenant environment, repeat these steps for each Oracle RAC node or PDB on which you enabled Oracle Label Security.

Enabling Oracle Label Security

You can enable Oracle Label Security in SQL*Plus.

1. Log into the database instance as user `sys` or a user who has been granted the `LBAC_DBA` role.

For example:

```
sqlplus psmith_ols -- Or, psmith_ols@hrpdb for the hrpdb PDB  
Enter password: password
```

2. Run the following procedure:

```
EXEC LBACSYS.OLS_ENFORCEMENT.ENABLE_OLS;
```

3. Restart the database.

For example:

```
CONNECT SYS AS SYSOPER  
Enter password: password
```

```
SHUTDOWN IMMEDIATE  
STARTUP
```

4. For Oracle Real Application Cluster (Oracle RAC) environment or a multitenant environment, repeat these steps for each Oracle RAC node or PDB on which you disabled Oracle Label Security.

B

Advanced Topics in Oracle Label Security

Oracle provides advanced functionality for Oracle Label Security, such as the ability to analyze relationships between labels.

- [Analyzing the Relationships Between Labels](#)
You can analyze the relationships between labels.
- [Queries for Audited Oracle Label Security Session Labels](#)
You can use the unified audit trail to capture information from various audit sources, including Oracle Label Security.
- [Oracle Call Interface for Setting Session Labels](#)
You can use an Oracle Call Interface (OCI) to set session labels.

Analyzing the Relationships Between Labels

You can analyze the relationships between labels.

- [About Dominant and Dominated Labels](#)
The relationship between two labels can be described in terms of *dominance*.
- [Non-Comparable Labels](#)
It is important to understand how labels can be compared with regard to dominance.
- [Using Dominance Functions](#)
Oracle Label Security provides functions to control dominance.

About Dominant and Dominated Labels

The relationship between two labels can be described in terms of *dominance*.

A user's ability to access an object depends on whether the user's label dominates the label of the object. If a user's label does not dominate the object's label, then the user is not allowed to access the object.

Label dominance is analyzed in terms of all its components: levels, compartments, and groups.

Table B-1 Dominance in the Comparison of Labels

| Factor | Criteria for Dominance |
|-------------|---|
| Level | For label1 to dominate label2, the level of label1 must be greater than or equal to that of label2. |
| Compartment | For label1 to dominate label2, the compartments of label1 must contain <i>all</i> the compartments of label2. |
| Group | For label1 to dominate label2, label1 must contain <i>at least one</i> of the groups of label2. |

One label *dominates* another label if all of its components dominate the components of the other label. For example, the label `HIGHLY_SENSITIVE:FINANCE,OPERATIONS` dominates the label `HIGHLY_SENSITIVE:FINANCE`. Similarly, the label `HIGHLY_SENSITIVE::WR_AP` dominates the label `HIGHLY_SENSITIVE::WR_AP, WR_AR`.

Related Topics

- [Dominance Rules for Labels with Inverse Groups](#)
You should understand how dominance rules work for Oracle labels and inverse groups.

Non-Comparable Labels

It is important to understand how labels can be compared with regard to dominance.

The relationship between two labels cannot always be defined by dominance. Two labels are *non-comparable* if neither label dominates the other.

If any compartments differ between the two labels (as with `HS:A` and `HS:B`), then they are non-comparable. Similarly, the labels `HS:A` and `S:B` are non-comparable.

You can find existing labels by querying the `DBA_SA_LABELS` data dictionary view.

Using Dominance Functions

Oracle Label Security provides functions to control dominance.

- [About the Dominance Functions](#)
You can use dominance functions to specify ranges in queries.
- [OLS_DOMINATES Standalone Function](#)
The `OLS_DOMINATES (OLS_DOM)` function returns 1 (TRUE) if `label1` dominates `label2`, or 0 (FALSE) if it does not.
- [OLS_LABEL_DOMINATES Standalone Function](#)
The standalone `OLS_LABEL_DOMINATES` function checks the dominance of session labels.
- [OLS_STRICTLY_DOMINATES Standalone Function](#)
The `OLS_STRICTLY_DOMINATES (OLS_S_DOM)` function returns 1 (TRUE) if `label1` dominates `label2` and is not equal to it.
- [OLS_DOMINATED_BY Standalone Function](#)
The `OLS_DOMINATED_BY (OLS_DOM_BY)` function returns 1 (TRUE) if `label1` is dominated by `label2`.
- [OLS_STRICTLY_DOMINATED_BY Standalone Function](#)
The `OLS_STRICTLY_DOMINATED_BY (OLS_S_DOM_BY)` function returns 1 (TRUE) if `label1` is dominated by `label2` and is not equal to it.
- [SA_UTL.DOMINATES](#)
The `SA_UTL.DOMINATES` function returns TRUE if `label1` dominates `label2` or if the session label for the given OLS policy dominates `label1`.
- [SA_UTL.STRICTLY_DOMINATES](#)
The `SA_UTL.STRICTLY_DOMINATES` function returns TRUE if `label1` dominates `label2` and is not equal to it.
- [SA_UTL.DOMINATED_BY](#)
The `SA_UTL.DOMINATED_BY` function returns TRUE if `label1` is dominated by `label2`.

- [SA_UTL.STRICTLY_DOMINATED_BY](#)
The `SA_UTL.STRICTLY_DOMINATED_BY` function returns `TRUE` if `label1` is dominated by `label2` and is not equal to it.

Related Topics

- [Ordering Labeled Data Rows](#)
The `ORDER BY` clause of a `SELECT` statement can be used to order rows by the numeric label tag.

About the Dominance Functions

You can use dominance functions to specify ranges in queries.

The following functions enable you to indicate dominance relationships between specified labels.

Table B-2 Functions to Determine Dominance

| Function | Description |
|--|---|
| <code>OLS_DOMINATES</code> | The value of <code>label1</code> dominates, or is equal to, that of <code>label2</code> . |
| <code>OLS_LABEL_DOMINATES</code> | The value of the session label for the corresponding <code>policy_name</code> dominates, or is equal to, that of <code>label</code> . |
| <code>OLS_STRICTLY_DOMINATES</code> | The value of <code>label1</code> dominates that of <code>label2</code> , and is not equal to it. |
| <code>OLS_DOMINATED_BY</code> | The value of <code>label1</code> is dominated by that of <code>label2</code> . |
| <code>OLS_STRICTLY_DOMINATED_BY</code> | The value of <code>label1</code> is dominated by that of <code>label2</code> , and is not equal to it. |

Note that there are two types of dominance function. While the `SA_UTL` dominance functions return `BOOLEAN` values, the standalone dominance functions return integers.

OLS_DOMINATES Standalone Function

The `OLS_DOMINATES (OLS_DOM)` function returns 1 (`TRUE`) if `label1` dominates `label2`, or 0 (`FALSE`) if it does not.

Syntax

```
OLS_DOMINATES (
  label1      IN NUMBER,
  label2      IN NUMBER)
RETURN INTEGER;
```

Parameters

Table B-3 OLS_DOMINATES Parameters

| Parameter | Description |
|-----------|---|
| label1 | The first label to check. To find existing label values, query the LABEL and TAG columns of the ALL_SA_LABELS view. |
| label2 | The second label to check |

Example

The following example compares existing label tags 1111 and 1112.

```
SELECT OLS_DOMINATES ('1111', '1112') FROM DUAL;

OLS_DOMINATES('1111', '1112')
-----
0
```

Note:

The old OLS functions, `DOMINATES` and `DOM`, have been deprecated in Oracle Database 12c release 1 (12.1).

You can still use the old functions in this release, but Oracle recommends that you use the `OLS_LABEL_DOMINATES` and `OLS_DOM` functions instead. Using the new function names avoids potential name conflicts with other database components.

OLS_LABEL_DOMINATES Standalone Function

The standalone `OLS_LABEL_DOMINATES` function checks the dominance of session labels.

It returns 1 (TRUE) if the session label of the specified `policy_name` value dominates or is equal to the label that is specified by the `label` parameter. Otherwise, this function returns 0 (FALSE). This function is publicly available.

Note:

This feature is available starting with Oracle Database 12c release 1 (12.1.0.2).

In addition to Oracle Label Security policies, you can use this function with both Oracle Data Redaction and Oracle Database Vault policies.

Syntax

```
OLS_LABEL_DOMINATES (
    policy_name    IN VARCHAR2,
```

```
label          IN VARCHAR2)
RETURN INTEGER;
```

Parameters

Table B-4 OLS_LABEL_DOMINATES Parameters

| Parameter | Description |
|-------------|--|
| policy_name | The name of the Oracle Label Security policy whose session label must be checked for dominance. To find existing label values for policies, query the POLICY_NAME and LABEL columns of the ALL_SA_LABELS view. |
| label | The base label against whom the dominance has to be checked |

Examples

The following example checks if the session label for the `hr_ols_pol` policy dominates or is equal to the `hs` label.

```
SELECT OLS_LABEL_DOMINATES ('hr_ols_pol', 'hs') FROM DUAL;

OLS_LABEL_DOMINATES('HR_OLS_POL','HS')
-----
0
```

This example shows how you can use the `OLS_LABEL_DOMINATES` function in an Oracle Data Redaction policy:

```
BEGIN
  DBMS_REDACT.ADD_POLICY(
    object_schema => 'oe',
    object_name   => 'customers',
    column_name   => 'customer_id',
    policy_name   => 'redact_cust_user_ids',
    function_type => DBMS_REDACT.FULL,
    expression    => 'OLS_LABEL_DOMINATES(''hr_ols_pol'', ''hs'') = 0');
END;
/
```

The following example shows how you can use the `OLS_LABEL_DOMINATES` function in an Oracle Database Vault rule definition:

```
EXEC DBMS_MACADM.CREATE_RULE('Check OLS Factor',
'OLS_LABEL_DOMINATES(''hr_ols_pol'', ''hs'') = 1');
```

See Also:

- *Oracle Database Advanced Security Guide* for more information about Data Redaction
- *Oracle Database Vault Administrator's Guide* for more information about Database Vault realms

OLS_STRICTLY_DOMINATES Standalone Function

The `OLS_STRICTLY_DOMINATES` (`OLS_S_DOM`) function returns 1 (TRUE) if `label1` dominates `label2` and is not equal to it.

Syntax

```
OLS_STRICTLY_DOMINATES (
  label1          IN NUMBER,
  label2          IN NUMBER)
RETURN INTEGER;
```

Parameters

Table B-5 OLS_STRICTLY_DOMINATES Parameters

| Parameter | Description |
|---------------------|--|
| <code>label1</code> | The first label to check. To find existing label values, query the <code>LABEL</code> and <code>TAG</code> columns of the <code>ALL_SA_LABELS</code> view. |
| <code>label2</code> | The second label to check |

Examples

The following example compares existing label tags 1111 and 1112.

```
SELECT OLS_STRICTLY_DOMINATES ('1111', '1112') FROM DUAL;

OLS_STRICTLY_DOMINATES('1111', '1112')
-----
0
```

Note:

The old OLS functions, `STRICTLY_DOMINATES` and `S_DOM` have been deprecated in Oracle Database 12c release 1 (12.1).

You can still use the old functions in this release, but Oracle recommends that you use the `OLS_STRICTLY_DOMINATES` and `OLS_S_DOM` functions instead. Using the new function names avoids potential name conflicts with other database components.

OLS_DOMINATED_BY Standalone Function

The `OLS_DOMINATED_BY` (`OLS_DOM_BY`) function returns 1 (TRUE) if `label1` is dominated by `label2`.

Syntax

```
OLS_DOMINATED_BY (
  label1          IN NUMBER,
  label2          IN NUMBER)
RETURN INTEGER;
```

Parameters

Table B-6 OLS_STRICTLY_DOMINATES Parameters

| Parameter | Description |
|-----------|---|
| label1 | The first label to check. To find existing label values, query the LABEL and TAG columns of the ALL_SA_LABELS view. |
| label2 | The second label to check |

Example

The following example compares existing label tags 1111 and 1112.

```
SELECT OLS_DOMINATED_BY ('1111', '1112') FROM DUAL;

OLS_DOMINATED_BY('1111','1112')
-----
1
```

Note:

The old OLS functions, `DOMINATED_BY` and `DOM_BY` have been deprecated in Oracle Database 12c release 1 (12.1).

You can still use the old functions in this release, but Oracle recommends that you use the `OLS_DOMINATED_BY` and `OLS_DOM_BY` functions instead. Using the new function names avoids potential name conflicts with other database components.

OLS_STRICTLY_DOMINATED_BY Standalone Function

The `OLS_STRICTLY_DOMINATED_BY` (`OLS_S_DOM_BY`) function returns 1 (TRUE) if `label1` is dominated by `label2` and is not equal to it.

Syntax

```
OLS_STRICTLY_DOMINATED_BY (
  label1          IN NUMBER,
  label2          IN NUMBER)
RETURN INTEGER;
```

Parameters

Table B-7 OLS_DOMINATES Parameters

| Parameter | Description |
|-----------|---|
| label1 | The first label to check. To find existing label values, query the LABEL and TAG columns of the ALL_SA_LABELS view. |
| label2 | The second label to check |

Example

The following example compares existing label tags 1111 and 1112.

```
SELECT OLS_STRICTLY_DOMINATES ('1111', '1112') FROM DUAL;

OLS_STRICTLY_DOMINATES('1111','1112')
-----
0
```



Note:

The old OLS functions, `STRICTLY_DOMINATED_BY` and `S_DOM_BY` have been deprecated in Oracle Database 12c release 1 (12.1).

You can still use the old functions in this release, but Oracle recommends that you use the `OLS_STRICTLY_DOMINATED_BY` and `OLS_S_DOM_BY` functions instead. Using the new function names avoids potential name conflicts with other database components.

SA_UTL.DOMINATES

The `SA_UTL.DOMINATES` function returns `TRUE` if `label1` dominates `label2` or if the session label for the given OLS policy dominates `label1`.

Syntax

```
SA_UTL.DOMINATES (
    label1      IN NUMBER,
    label2      IN NUMBER)
RETURN BOOLEAN;
```

Syntax

```
SA_UTL.DOMINATES (
    ols_policy_name IN VARCHAR2,
    label           IN VARCHAR2)
RETURN BOOLEAN;
```

Parameters

Table B-8 SA_UTL.DOMINATES Parameters

| Parameter | Description |
|---------------------|--|
| <code>label1</code> | The first label to check. To find existing label values, query the <code>LABEL</code> and <code>TAG</code> columns of the <code>ALL_SA_LABELS</code> view. |
| <code>label2</code> | The second label to check |

Example

The following example compares existing label tags 1111 and 1112.

```

SET SERVEROUTPUT ON
BEGIN
  IF SA_UTL.DOMINATES(1111, 1112)
    THEN DBMS_OUTPUT.PUT_LINE('Label 1111 dominates label 1112.');
```

```

  ELSE
    DBMS_OUTPUT.PUT_LINE('Label 1112 dominates label 1111.');
```

```

  END IF;
END;
/
```

Label 1112 dominates label 1111.

Note:

The second `SA_UTL.DOMINATES` function, which takes the Oracle Label Security policy name and label as inputs, has been deprecated in Oracle Database 12c release 1 (12.1).

You can still use this function, but not with Oracle Data Redaction and Oracle Database Vault conditions. Oracle recommends that you use the `OLS_LABEL_DOMINATES` function instead.

The first `SA_UTL.DOMINATES` function, which uses the `NUMBER` datatype, is not deprecated.

SA_UTL.STRICTLY_DOMINATES

The `SA_UTL.STRICTLY_DOMINATES` function returns `TRUE` if `label1` dominates `label2` and is not equal to it.

Syntax

```

SA_UTL.STRICTLY_DOMINATES (
  label1      IN NUMBER,
  label2      IN NUMBER)
RETURN BOOLEAN;
```

Parameters

Table B-9 SA_UTL.STRICTLY_DOMINATES Parameters

| Parameter | Description |
|---------------------|--|
| <code>label1</code> | The first label to check. To find existing label values, query the <code>LABEL</code> and <code>TAG</code> columns of the <code>ALL_SA_LABELS</code> view. |
| <code>label2</code> | The second label to check |

Example

The following example compares existing label tags 1111 and 1112.

```

SET SERVEROUTPUT ON
BEGIN
  IF SA_UTL.STRICTLY_DOMINATES(1111, 1112)
    THEN DBMS_OUTPUT.PUT_LINE('Label 1111 strictly dominates label 1112.');
```

```

ELSE
  DBMS_OUTPUT.PUT_LINE('Label 1112 strictly dominates label 1111.');
```

Label 1112 strictly dominates label 1111.

SA_UTL.DOMINATED_BY

The `SA_UTL.DOMINATED_BY` function returns `TRUE` if `label1` is dominated by `label2`.

Syntax

```

SA_UTL.DOMINATED_BY (
  label1          IN NUMBER,
  label2          IN NUMBER)
RETURN BOOLEAN;
```

Parameters

Table B-10 SA_UTL.DOMINATED_BY Parameters

| Parameter | Description |
|---------------------|--|
| <code>label1</code> | The first label to check. To find existing label values, query the <code>LABEL</code> and <code>TAG</code> columns of the <code>ALL_SA_LABELS</code> view. |
| <code>label2</code> | The second label to check |

Example

The following example compares existing label tags 1111 and 1112.

```

SET SERVEROUTPUT ON
BEGIN
  IF SA_UTL.DOMINATED_BY(1111, 1112)
    THEN DBMS_OUTPUT.PUT_LINE('Label 1111 is dominated by label 1112.');
```

Label 1111 is dominated by label 1112.

SA_UTL.STRICTLY_DOMINATED_BY

The `SA_UTL.STRICTLY_DOMINATED_BY` function returns `TRUE` if `label1` is dominated by `label2` and is not equal to it.

Syntax

```

SA_UTL.STRICTLY_DOMINATED_BY (
  label1          IN NUMBER,
  label2          IN NUMBER)
RETURN BOOLEAN;
```

Parameters

Table B-11 SA_UTL.STRICTLY_DOMINATED_BY Parameters

| Parameter | Description |
|-----------|---|
| label1 | The first label to check. To find existing label values, query the LABEL and TAG columns of the ALL_SA_LABELS view. |
| label2 | The second label to check |

Example

The following example compares existing label tags 1111 and 1112.

```
SET SERVEROUTPUT ON
BEGIN
  IF SA_UTL.STRICTLY_DOMINATED_BY(1111, 1112)
    THEN DBMS_OUTPUT.PUT_LINE('Label 1111 is strictly dominated by label 1112.');
```

```
ELSE
```

```
  DBMS_OUTPUT.PUT_LINE('Label 1112 is strictly dominated by label 1111.');
```

```
END IF;
```

```
END;
```

```
/
```

Label 1111 is strictly dominated by label 1112.

Related Topics

- [Determination of the Upper and Lower Bounds of Labels](#)
Oracle Label Security provides functions that determine the least upper bound or the greatest lower bound of two or more labels.

Queries for Audited Oracle Label Security Session Labels

You can use the unified audit trail to capture information from various audit sources, including Oracle Label Security.

- [About Queries for Auditing Oracle Label Security Session Labels](#)
You must configure Oracle Label Security auditing by creating unified audit policies.
- [ORA_GET_AUDITED_LABEL Function](#)
The `ORA_GET_AUDITED_LABEL` function returns the audited session label for the specified OLS policy and `APPLICATION_CONTEXTS` column value.

About Queries for Auditing Oracle Label Security Session Labels

You must configure Oracle Label Security auditing by creating unified audit policies.

OLS auditing enables you to audit additional events such as enabling and disabling of OLS policies.

The session labels that the audit trail captures are stored in the `APPLICATION_CONTEXTS` column of the `UNIFIED_AUDIT_TRAIL` view. You can use the `LBACSYS.ORA_GET_AUDITED_LABEL` function to retrieve session labels that are stored in the `APPLICATION_CONTEXTS` column. This function accepts the

UNIFIED_AUDIT_TRAIL.APPLICATION_CONTEXTS column value, and the Oracle Label Security policy name as arguments, and then returns the session label that is stored in the column for the specified policy.



See Also:

Oracle Database Security Guide for detailed information about configuring and using OLS auditing in a unified audit trail

ORA_GET_AUDITED_LABEL Function

The ORA_GET_AUDITED_LABEL function returns the audited session label for the specified OLS policy and APPLICATION_CONTEXTS column value.

The AUDIT_VIEWER role has EXECUTE privilege on the ORA_GET_AUDITED_LABEL function.

Syntax

```
ORA_GET_AUDITED_LABEL (
  appctx_col_value  IN VARCHAR2,
  ols_policy_name   IN VARCHAR2)
RETURN VARCHAR2;
```

Parameters

Table B-12 ORA_GET_AUDITED_LABEL Parameters

| Parameter | Description |
|------------------|--|
| appctx_col_value | Value in the UNIFIED_AUDIT_TRAIL.APPLICATION_CONTEXTS column |
| policy_name | The label security policy name |

Example

The following example returns the audited session label for the hr_ols_pol policy.

```
SELECT ORA_GET_AUDITED_LABEL ('cust_ctx', 'hr_ols_pol') FROM DUAL;

ORA_GET_AUDITED_LABEL('X', 'HR_OLS_POL')
-----
HS
```

Oracle Call Interface for Setting Session Labels

You can use an Oracle Call Interface (OCI) to set session labels.

- [About Using the Oracle Call Interface to Set Session Labels](#)
When you connect using Oracle Call Interface (OCI), you can use the SYS_CONTEXT variables to initialize the session label and the row label.
- [Using the Oracle Call Interface to Set Session Labels](#)
You can use the Oracle Call Interface to set the session labels.

- [Example: Using Oracle Call Interface with the SYS_CONTEXT Function](#)
You can create an OCI call that uses an externalized SYS_CONTEXT function with Oracle Label Security.

About Using the Oracle Call Interface to Set Session Labels

When you connect using Oracle Call Interface (OCI), you can use the SYS_CONTEXT variables to initialize the session label and the row label.

You can set the variables using the OCIAttrSet function to initialize *externally initialized* SYS_CONTEXT variables. These are available when Oracle Label Security is enabled.

Each policy has a SYS_CONTEXT named SA\$policy_name_X. You can set these two variables, INITIAL_LABEL and INITIAL_ROW_LABEL.

When the new values are set to valid labels within the user's authorizations, they will be used instead of the default values stored for the user. This is the same mechanism used for remote connections.

Related Topics

- [Using Oracle Label Security with a Distributed Database](#)
You should understand the special considerations for using Oracle Label Security in a distributed configuration.

Using the Oracle Call Interface to Set Session Labels

You can use the Oracle Call Interface to set the session labels.

1. Call OCIAttrSet with OCI_ATTR_APPCTX_SIZE to initialize the context array size with the desired number of context attributes:

```
OCIAttrSet(session, OCI_HTYPE_SESSION,
           (dvoid *)&size, (ub4)0, OCI_ATTR_APPCTX_SIZE, error_handle);
```

This defines additional attributes for OCIAttrSet.

Note that the size is ub4 type.

2. Call OCIAttrGet with OCI_ATTR_APPCTX_LIST to get a handle on the application context list descriptor for the session:

```
OCIAttrGet(session, OCI_HTYPE_SESSION,
           (dvoid *)&ctxl_desc, (ub4)0, OCI_ATTR_APPCTX_LIST, error_handle);
```

Note that ctxl_desc is (OCIParam *) type.

3. Call OCIParamGet with the application context list descriptor to obtain an individual descriptor for the *i*-th application context:

```
OCIParamGet(ctxl_desc, OCI_DTYPE_PARAM, error_handle, (dvoid **)&ctx_desc, i);
```

Note that ctx_desc is (OCIParam *) type.

4. Call OCIAttrSet with each of the three new attributes, OCI_ATTR_APPCTX_NAME, OCI_ATTR_APPCTX_ATTR, and OCI_ATTR_APPCTX_VALUE, to set the proper values in the application context:

```
OCIAttrSet(ctx_desc, OCI_DTYPE_PARAM,
           (dvoid *)ctx_name, sizeof(ctx_name), OCI_ATTR_APPCTX_NAME,
```

```

        error_handle);

OCIAttrSet(ctx_desc, OCI_DTYPE_PARAM,
           (dvoid *)attr_name, sizeof(attr_name), OCI_ATTR_APPCTX_ATTR,
           error_handle);

OCIAttrSet(ctx_desc, OCI_DTYPE_PARAM,
           (dvoid *)value, sizeof(value), OCI_ATTR_APPCTX_VALUE,
           error_handle);

```

Note that only character type is supported, because application context operations are based on the VARCHAR2 type.

Example: Using Oracle Call Interface with the SYS_CONTEXT Function

You can create an OCI call that uses an externalized SYS_CONTEXT function with Oracle Label Security.

[Example B-1](#) shows how to accomplish this.

Example B-1 Using OCI to Externalize SYS_CONTEXT with OLS

```

#ifdef RCSID
static char *RCSid =
    "$Header: ext_mls.c 09-may-00.10:07:08 jdoe Exp $ ";
#endif /* RCSID */

/* Copyright (c) Oracle Corporation 1999, 2000. All Rights Reserved. */

/*

NAME
ext_mls.c - externalized SYS_CONTEXT with Label Security

DESCRIPTION
Run olsdemo.sql script before executing this example.
Usage: <executable obtained with .c file> <user_name> <password> <session-initial-
label
Example: avg_sal sa_demo sa_demo L3:M,E:D10

PUBLIC FUNCTION(S)
<list of external functions declared/defined - with one-line descriptions>

PRIVATE FUNCTION(S)
<list of static functions defined in .c file - with one-line descriptions>

RETURNS
The average salary in the EMP table of the SA_DEMO schema querying as the specified
user with the specified session label.

NOTES
<other useful comments, qualifications, and so on>

MODIFIED   (MM/DD/YY)
jlev      09/18/03 - cleanup
jdoe      05/09/00 - cleanup
jdoe      10/13/99 - standalone OCI program to test MLS SYS_CONTEXT
jdoe      10/13/99 - Creation

```

```

*/
#include <stdio.h>
#include <stdlib.h>
#include <string.h>
#include <oci.h>

static OCIEnv *envhp;
static OCIError *errhp;

int main(/*_ int argc, char *argv[] _*/);

/* get and print error */
static void checkerr(/*_OCIError *errhp, sword status _*/);
/* print error */
static void printerr(char *call);
static sword status;

/* return the average of employees' salary */
static CONST text *const selectstmt = (text *)
    "select avg(sal) from sa_demo.emp";

int main(argc, argv)
int argc;
char *argv[];
{
    OCISession *authp = (OCISession *) 0;
    OCIServer *srvhp;
    OCISvcCtx *svchp;
    OCIDefine *defnp = (OCIDefine *) 0;
    dvoid *parmdp;
    ub4 ctxsize;
    OCIParam *ctxldesc;
    OCIParam *ctxedesc;
    OCISstmt *stmtsp = (OCISstmt *) 0;
    ub4 avg_sal = 0;
    sword status;

    if (OCIInitialize((ub4) OCI_DEFAULT, (dvoid *) 0,
        (dvoid * (*)(dvoid *, size_t)) 0,
        (dvoid * (*)(dvoid *, dvoid *, size_t)) 0,
        (void (*)(dvoid *, dvoid *)) 0))
        printerr("OCIInitialize");

    if (OCIEnvInit((OCIEnv **) &envhp, OCI_DEFAULT, (size_t) 0, (dvoid **) 0))
        printerr("OCIEnvInit");

    if (OCIHandleAlloc((dvoid *) envhp, (dvoid **) &errhp, OCI_HTYPE_ERROR,
        (size_t) 0, (dvoid **) 0))
        printerr("OCIHandleAlloc:OCI_HTYPE_ERROR");

    if (OCIHandleAlloc((dvoid *) envhp, (dvoid **) &srvhp, OCI_HTYPE_SERVER,
        (size_t) 0, (dvoid **) 0))
        printerr("OCIHandleAlloc:OCI_HTYPE_SERVER");

    if (OCIHandleAlloc((dvoid *) envhp, (dvoid **) &svchp, OCI_HTYPE_SVCCTX,
        (size_t) 0, (dvoid **) 0))
        printerr("OCIHandleAlloc:OCI_HTYPE_SVCCTX");

    if (OCIServerAttach(srvhp, errhp, (text *) "", strlen(""), 0))
        printerr("OCIServerAttach");

```

```

/* set attribute server context in the service context */
if (OCIAttrSet((dvoid *) svchp, OCI_HTYPE_SVCCTX, (dvoid *) srvhp,
              (ub4) 0, OCI_ATTR_SERVER, (OCIError *) errhp))
    printerr("OCIAttrSet:OCI_HTYPE_SVCCTX");

if (OCIHandleAlloc((dvoid *) envhp, (dvoid **) &authp,
                  (ub4) OCI_HTYPE_SESSION, (size_t) 0, (dvoid **) 0))
    printerr("OCIHandleAlloc:OCI_HTYPE_SESSION");

/* set application context to 1 */
ctxsize = 1;

/* set up app ctx buffer */
if (OCIAttrSet((dvoid *) authp, (ub4) OCI_HTYPE_SESSION, (dvoid *) &ctxsize,
              (ub4) 0, (ub4) OCI_ATTR_APPCTX_SIZE, errhp))
    printerr("OCIAttrSet:OCI_ATTR_APPCTX_SIZE");

/* retrieve the list descriptor */
if (OCIAttrGet((dvoid *) authp, (ub4) OCI_HTYPE_SESSION,
              (dvoid *) &ctxldesc, 0, OCI_ATTR_APPCTX_LIST, errhp))
    printerr("OCIAttrGet:OCI_ATTR_APPCTX_LIST");

if (status = OCIParamGet(ctxldesc, OCI_DTYPE_PARAM, errhp,
                        (dvoid **) &ctxedesc, 1))
    {
        if (status == OCI_NO_DATA)
            {
                printf("No Data found!\n");
                exit(1);
            }
    }

/* set context namespace to SA$<pol_name>_X */
if (OCIAttrSet((dvoid *) ctxedesc, (ub4) OCI_DTYPE_PARAM,
              (dvoid *) "SA$HUMAN_RESOURCES_X",
              (ub4) strlen((char *) "SA$HUMAN_RESOURCES_X"),
              (ub4) OCI_ATTR_APPCTX_NAME, errhp))
    printerr("OCIAttrSet:OCI_ATTR_APPCTX_NAME:SA$HUMAN_RESOURCES_X");

/* set context attribute to INITIAL_LABEL */
if (OCIAttrSet((dvoid *) ctxedesc, (ub4) OCI_DTYPE_PARAM,
              (dvoid *) "INITIAL_LABEL",
              (ub4) strlen((char *) "INITIAL_LABEL"),
              (ub4) OCI_ATTR_APPCTX_ATTR, errhp))
    printerr("OCIAttrSet:OCI_DTYPE_PARAM:INITIAL_LABEL");

/* set context value to argv[3] - initial label */
if (OCIAttrSet((dvoid *) ctxedesc, (ub4) OCI_DTYPE_PARAM,
              (dvoid *) argv[3],
              (ub4) strlen((char *) argv[3]),
              (ub4) OCI_ATTR_APPCTX_VALUE, errhp))
    printerr("OCIAttrSet:argv[3]");

/* username first command line argument */
if (OCIAttrSet((dvoid *) authp, (ub4) OCI_HTYPE_SESSION, (dvoid *) argv[1],
              (ub4) strlen((char *) argv[1]), (ub4) OCI_ATTR_USERNAME,
              errhp))
    printerr("OCIAttrSet:username");

/* password second command line argument */

```

```

if (OCIAttrSet((dvoid *) authp, (ub4) OCI_HTYPE_SESSION, (dvoid *) argv[2],
              (ub4) strlen((char *) argv[2]), (ub4) OCI_ATTR_PASSWORD,
              errhp))
    printerr("OCIAttrSet:password");

if (OCISessionBegin(svchp, errhp, authp, OCI_CRED_RDBMS, (ub4) OCI_DEFAULT))
    printerr("OCISessionBegin");

if (OCIAttrSet((dvoid *) svchp, (ub4) OCI_HTYPE_SVCCTX, (dvoid *) authp,
              (ub4) 0, (ub4) OCI_ATTR_SESSION, errhp))
    printerr("OCIAttrSet:OCI_ATTR_SESSION");

if (OCIHandleAlloc((dvoid *) envhp, (dvoid **) &stmtp, OCI_HTYPE_STMT,
                  0, 0))
    printerr("OCIHandleAlloc:OCI_HTYPE_STMT");

if (OCISstmtPrepare(stmtp, errhp, (CONST OraText *) selectstmt,
                  (ub4) strlen((const char *) selectstmt),
                  (ub4) OCI_NTV_SYNTAX, (ub4) OCI_DEFAULT))
    printerr("OCISstmtPrepare");

if (OCIDefineByPos(stmtp, &defnp, errhp, (ub4) 1, (dvoid *) &avg_sal,
                  (sb4) sizeof(avg_sal), SQLT_INT, 0, 0, 0, OCI_DEFAULT))
    printerr("OCIDefineByPos");

if (status = OCISstmtExecute(svchp, stmtp, errhp, 1, 0, NULL, NULL,
                            OCI_DEFAULT))
    {
        if (status == OCI_NO_DATA)
            {
                printf("No Data found!\n");
                exit(1);
            }
    }

if (OCISessionEnd(svchp, errhp, authp, OCI_DEFAULT))
    printerr("OCISessionEnd");

printf("average salary is: %d\n", avg_sal);
}

void checkerr(errhp, status)
    OCIError *errhp;
    sword status;
{
    text errbuf[512];
    sb4 errcode = 0;

    switch (status)
        {
        case OCI_ERROR:
            (void) OCIErrorGet((dvoid *) errhp, 1, NULL, &errcode, errbuf,
                              (ub4) sizeof(errbuf), OCI_HTYPE_ERROR);
            printf("Error - %.*s\n", 512, errbuf);
            break;
        default:
            break;
        }
}

void printerr(call)

```

```
    char *call;
    {
    printf("Error: %s\n", call);
    }
/* end of file ext_mls.c */
```

C

Command-line Tools for Label Security Using Oracle Internet Directory

Oracle Label Security provides command-line tools for using Oracle Internet Directory.

- [About the Command-line Oracle Label Security Tools](#)
When you use Oracle Label Security with Oracle Internet Directory, you can create and alter label security attributes stored in the directory.
- [Oracle Label Security Commands in Categories](#)
Oracle Label Security commands can be categorized according to policies, levels, groups, and so on.
- [olsadmintool Command Reference](#)
The `olsadmintool` commands performs tasks such as adding enterprise users to administrative groups for an Oracle Label Security policy.
- [Relating Parameters to Commands for `olsadmintool`](#)
You must follow a set of guidelines for using the `olsadmintool` parameters.
- [Examples of Using the `olsadmintool` Utility](#)
You use the `olsadmintool` commands to set up Oracle Label Security in an Oracle Internet Directory environment.

About the Command-line Oracle Label Security Tools

When you use Oracle Label Security with Oracle Internet Directory, you can create and alter label security attributes stored in the directory.

The commands perform updates, inserts and deletes of entries in the directory and are implemented through a script named `olsadmintool`, which you call from `$ORACLE_HOME/bin/olsadmintool`.

Note:

You can also use the graphical user interface provided by Oracle Enterprise Manager to manage Oracle Label Security. Detailed documentation can be found in Oracle Enterprise Manager help.

Oracle Label Security Commands in Categories

Oracle Label Security commands can be categorized according to policies, levels, groups, and so on.

[Table C-1](#) lists all the commands, in categories, with links to their explanations.

Some of these commands replace PL/SQL procedures that are used for the indicated purposes when Oracle Label Security is used without Oracle Internet Directory. Sites

already using Oracle Label Security that add Oracle Internet Directory must replace the use of those PL/SQL procedures by switching to use these new commands instead.

Table C-1 Oracle Label Security Commands in Categories

| Command Category | Command | Replaces PL/SQL Statement |
|--------------------------|--|---|
| Policies | olsadmintool createpolicy | SA_SYSDBA.CREATE_POLICY |
| Policies | olsadmintool alterpolicy | SA_SYSDBA.ALTER_POLICY |
| Policies | olsadmintool droppolicy | SA_SYSDBA.DROP_POLICY |
| Policies | olsadmintool addpolcreator | None; new |
| Policies | olsadmintool droppolcreator | None; new |
| Levels in a Policy | olsadmintool createlevel | SA_COMPONENTS.CREATE_LEVEL |
| Levels in a Policy | olsadmintool alterlevel | SA_COMPONENTS.ALTER_LEVEL |
| Levels in a Policy | olsadmintool droplevel | SA_COMPONENTS.DROP_LEVEL |
| Groups in a Policy | olsadmintool creategroup | SA_COMPONENTS.CREATE_GROUP |
| Groups in a Policy | olsadmintool altergroup | SA_COMPONENTS.ALTER_GROUP |
| Groups in a Policy | olsadmintool altercompartment | SA_COMPONENTS.ALTER_GROUP_PARENT |
| Groups in a Policy | olsadmintool dropgroup | SA_COMPONENTS.DROP_GROUP |
| Compartments in a Policy | olsadmintool createcompartment | SA_COMPONENTS.CREATE_COMPARTMENT |
| Compartments in a Policy | olsadmintool altercompartment | SA_COMPONENTS.ALTER_COMPARTMENT |
| Compartments in a Policy | olsadmintool dropcompartment | SA_COMPONENTS.DROP_COMPARTMENT |
| Data Labels | olsadmintool createlabel | SA_LABEL_ADMIN.CREATE_LABEL |
| Data Labels | olsadmintool alterlabel | SA_LABEL_ADMIN.ALTER_LABEL |
| Data Labels | olsadmintool droplabel | SA_LABEL_ADMIN.DROP_LABEL |
| Users | olsadmintool adduser | None; new |
| Users | olsadmintool dropuser | SA_USER_ADMIN.DROP_USER_ACCESS |
| Profiles | olsadmintool createprofile | Replaces the use of several methods. ¹ |
| Profiles | olsadmintool listprofile | None; new |
| Profiles | olsamindtool describeprofile | None; new |
| Profiles | olsadmintool dropprofile | None; new |
| Policy Administrators | olsadmintool addadmin | None; new |

Table C-1 (Cont.) Oracle Label Security Commands in Categories

| Command Category | Command | Replaces PL/SQL Statement |
|----------------------|---|---------------------------|
| Policy Administrator | olsadmintool dropadmins | None; new |
| Auditing | olsadmintool audit | SA_AUDIT_ADMIN.AUDIT |
| Auditing | olsadmintool noaudit | SA_AUDIT_ADMIN.NOAUDIT |
| Help | olsadmintool --help | None; new |

¹ Replaces several methods in SA_USER_ADMIN: SET_LEVELS, SET_USER_PRIVILEGES, and SET_DEFAULT_LABEL

olsadmintool Command Reference

The `olsadmintool` commands performs tasks such as adding enterprise users to administrative groups for an Oracle Label Security policy.

You must run `olsadmintool` from the command line.

- [About the olsadmintool Commands](#)
You run the `olsadmintool` commands from a command prompt and can use special characters to perform specific operations.
- [olsadmintool addadmin](#)
The `olsadmintool addadmin` command adds an enterprise user to the administrative group for a policy.
- [olsadmintool addpolcreator](#)
The `olsadmintool addpolcreator` command enables the specified user to create policies.
- [olsadmintool adduser](#)
The `olsadmintool adduser` command adds an enterprise user to a profile within a policy.
- [olsadmintool altercompartment](#)
The `olsadmintool altercompartment` command changes the long name of a compartment.
- [olsadmintool altergroup](#)
The `olsadmintool altergroup` command changes the long name for a group component or parent group.
- [olsadmintool altergroupparent](#)
The `olsadmintool altergroupparent` command changes or removes the parent group of a group.
- [olsadmintool alterlabel](#)
The `olsadmintool alterlabel` command changes the character string defining the label associated with a label tag.
- [olsadmintool alterlevel](#)
The `olsadmintool alterlevel` command changes the long name of a level.

- [olsadmintool alterpolicy](#)
The `olsadmintool alterpolicy` command alters the options of a policy.
- [olsadmintool audit](#)
The `olsadmintool audit` command sets the audit options for a policy.
- [olsadmintool createcompartment](#)
The `olsadmintool createcompartment` command creates a new compartment component.
- [olsadmintool creategroup](#)
The `olsadmintool creategroup` command creates a new group component.
- [olsadmintool createlabel](#)
The `olsadmintool createlabel` command creates a valid data label.
- [olsadmintool createlevel](#)
The `olsadmintool createlevel` command creates a new level component.
- [olsadmintool createprofile](#)
The `olsadmintool createprofile` command creates a new profile.
- [olsadmintool createpolicy](#)
The `olsadmintool createpolicy` command creates a policy.
- [olsadmintool describepolicy](#)
The `olsadmintool describepolicy` command enables you to see the contents of a policy profile.
- [olsadmintool dropadmin](#)
The `olsadmintool dropadmin` command removes an enterprise user from the administrative group of a policy.
- [olsadmintool dropcompartment](#)
The `olsadmintool dropcompartment` command removes a compartment component.
- [olsadmintool dropgroup](#)
The `olsadmintool dropgroup` command removes a group component.
- [olsadmintool droplabel](#)
The `olsadmintool droplabel` command drops a label from the policy.
- [olsadmintool droplevel](#)
The `olsadmintool droplevel` command removes a level component from a specified policy.
- [olsadmintool droppolicy](#)
The `olsadmintool droppolicy` command drops a policy.
- [olsadmintool dropprofile](#)
The `olsadmintool dropprofile` command removes the specified profile.
- [olsadmintool droppolcreator](#)
The `olsadmintool droppolcreator` command cancels the ability of the specified user to create policies.
- [olsadmintool dropuser](#)
The `olsadmintool dropuser` command drops a user from the specified profile in the specified policy.
- [olsadmintool --help](#)
The `olsadmintool command_name -- help` command displays help information about the specified command.

- [olsadmintool noaudit](#)
The `olsadmintool noaudit` command cancels the audit options for a policy.
- [olsadmintool listprofile](#)
The `olsadmintool listprofile` command to see a list of all profiles in a given policy.

About the olsadmintool Commands

You run the `olsadmintool` commands from a command prompt and can use special characters to perform specific operations.

In the `olsadmintool` commands, some parameters are optional, which is indicated by enclosing such a parameter within brackets. The two most common examples are [`-b admin context`] and [`-p port`], indicating that it is optional to specify either the administrative context for the command or the port through which to connect to Oracle Internet Directory. (Default port is 389.)

The use of two dashes (`--`, no space) is required for all parameters other than `b`, `h`, `p`, `D`, and `w`, which are preceded by a single dash. The double dash indicates the need to specify the full or long version of the name or parameter being used. If any such name or parameter contains spaces, it must be enclosed by double quotation marks, for example, "this is an extremely long name or parameter."

olsadmintool addadmin

The `olsadmintool addadmin` command adds an enterprise user to the administrative group for a policy.

This enables the user to create, modify, or delete the specified policy's metadata. You must provide the policy name and the new administrator's DN. This group should contain only enterprise users.

Syntax

```
olsadmintool addadmin --polname policy_name --adminDN admin_DN  
[ -b admin_context ] -h OID_host [ -p port ] -D bind_DN -w bind_password
```

Example

```
olsadmintool addadmin --polname defense --adminDN "cn=scott,c=us"  
-h sales_west -D cn=lbacsys -w bind_password
```

olsadmintool addpolcreator

The `olsadmintool addpolcreator` command enables the specified user to create policies.

You must provide the DN for the user.

Syntax

```
olsadmintool addpolcreator --userDN user_DN  
[ -b admin_context ] -h OID_host [ -p port ] -D bind_DN -w bind_password
```

Examples

```
olsadmintool addpolcreator --userdn "cn=scott" -h sales_west -D cn=lbacsys -w  
bind_password
```

olsadmintool adduser

The `olsadmintool adduser` command adds an enterprise user to a profile within a policy.

You must provide the profile and policy names and the user DN.¹ Enterprise users are normal Oracle Internet Directory users with the additional capability of connecting to the database. Users added to a profile must be enterprise users.

Syntax

```
olsadmintool adduser --polname policy_name --profname profile_name --userdn  
enterprise_user_DN[ -b admin_context ] -h OID_host [-p port] -D bind_DN  
-w bind_password
```

Example

```
olsadmintool adduser --polname tradesecret --profname topsales --userdn "cn=perot"  
-b "cn=EDS" -h ford -p 1890 -D cn=lbacsys -w bind_password
```

olsadmintool altercompartment

The `olsadmintool altercompartment` command changes the long name of a compartment.

You must provide the name of the policy, the short name of the compartment, and the new long name of the compartment.

Syntax

```
olsadmintool altercompartment --polname policy_name --shortname  
short_compartment_name --longname new_long_compartment_name  
[ -b admin_context ] -h OID_host [-p port] -D bind_DN -w bind_password
```

Example

```
olsadmintool altercompartment --polname defense --shortname A --longname "Allied  
Forces" -h sales_west -D cn=defense_admin -w bind_password
```

olsadmintool altergroup

The `olsadmintool altergroup` command changes the long name for a group component or parent group.

You must provide the name of the policy, the short name of the group, and the long name of the group.

¹ Command Footnote Every command must include the directory host name, the bind DN, and the bind password. Any command may, as needed, also supply the subscriber administrative context (optional), the directory port number (also optional), or both. See also [Table C-2](#) for additional details on these parameters.

Syntax

```
olsadmintool altergroup --polname policy_name --shortname short_group_name  
--longname "new_long_group_name"  
[ -b admin_context ] -h OID_host [-p port] -D bind_DN -w bind_password
```

Example

```
olsadmintool altergroup --polname defense --shortname US --longname "United States  
of America" -h sales_west -D cn=defense_admin -w bind_password
```

olsadmintool altergroupparent

The `olsadmintool altergroupparent` command changes or removes the parent group of a group.

You must provide the name of the policy, the short name of the group, and either the short name of the parent group or the `clearparent` flag, but not both.

Syntax

```
olsadmintool altergroupparent --polname policy_name --shortname  
short_group_name [--parentname new_parent_group_name ] [--clearparent]  
--longname "new_long_group_name" [--parentname new_short_group_name ]  
[ -b admin_context ] -h OID_host [-p port] -D bind_DN -w bind_password
```

Examples

```
olsadmintool altergroupparent --polname defense --shortname US --parentname  
"Earth" -h sales_west -p 5678 -D cn=defense_admin -w bind_password
```

```
olsadmintool altergroupparent --polname defense --shortname US --clearparent  
-h sales_west -p 5678 -D cn=defense_admin -w bind_password
```

olsadmintool alterlabel

The `olsadmintool alterlabel` command changes the character string defining the label associated with a label tag.

You must provide the policy name, the numeric tag of the label, and the new character string representing the label.

Syntax

```
olsadmintool alterlabel --polname policy_name --tag tag_number  
--value new_label_value [ -b admin_context ] -h OID_host [-p port]  
-D bind_DN -w bind_password
```

Example

```
olsadmintool alterlabel --polname defense --tag 100 --value "TS:A:US" -h sales_west -  
D cn=defense_admin -w bind_password
```

olsadmintool alterlevel

The `olsadmintool alterlevel` command changes the long name of a level.

You must provide the name of the policy, the short name of the level, and the new long name of the level.

Syntax

```
olsadmintool alterlevel --polname policy_name --shortname short_level_name  
--longname "new_long_level_name"  
[ -b admin_context ] -h OID_host [-p port] -D bind_DN -w bind_password
```

Example

```
olsadmintool alterlevel --polname defense --shortname TS  
--longname "VERY TOP SECRET" -h sales_west -D cn=defense_admin -w bind_password
```

olsadmintool alterpolicy

The `olsadmintool alterpolicy` command alters the options of a policy.

You must provide the name of the policy and the new options.

Syntax

```
olsadmintool alterpolicy --name policy_name --options new_options  
[ -b admin_context ] -h OID_host [-p port] -D bind_DN -w bind_password
```

In this specification:

- *new_options* can be any combination of the following entries: INVERSE_GROUP, HIDE, LABEL_DEFAULT, LABEL_UPDATE, CHECK_CONTROL, READ_CONTROL, WRITE_CONTROL, INSERT_CONTROL, DELETE_CONTROL, UPDATE_CONTROL, ALL_CONTROL, NO_CONTROL

Example

```
olsadmintool alterpolicy --name defense --options "READ_CONTROL,INSERT_CONTROL"  
-h sales_west -D cn=defense_admin -w bind_password
```

olsadmintool audit

The `olsadmintool olsadmintool audit` command sets the audit options for a policy.

You must provide the policy name, the options to be audited, the type of audit, and the type of success to be audited.

Syntax

```
olsadmintool audit --polname policy_name --options audit_option_name  
--type audit_option_type --success audit_success_type  
[ -b admin_context ] -h OID_host [-p port] -D bind_DN -w bind_password
```

In this specification:

- *audit_option* can be any combination of the following entries: APPLY, REMOVE, SET, PRIVILEGE
- *type* can be session or access
- *success* can be successful, not successful, or both

Example

```
olsadmintool audit --polname defense --options "APPLY,PRIVILEGE" --type session
--success success -h sales_west -D cn=defense_admin -w bind_password
```

olsadmintool createcompartment

The `olsadmintool createcompartment` command creates a new compartment component.

You must provide the name of the policy, the tag numeric value of the compartment, the short name of the compartment, and the long name of the compartment.

Syntax

```
olsadmintool createcompartment --polname policy_name --tag tag_number
--shortname short_compartment_name --longname <"long_compartment_name">
[ -b admin_context ] -h OID_host [-p port] -D bind_DN -w bind_password
```

Example

```
olsadmintool createcompartment --polname defense --tag 100 --shortname A
--longname Alpha -h sales_west -D cn=defense_admin -w bind_password
```

olsadmintool creategroup

The `olsadmintool creategroup` command creates a new group component.

You must provide the name of the policy, the tag numeric value of the group, the short name of the group, the long name of the group, and the parent group name (optional).

Syntax

```
olsadmintool creategroup --polname policy_name --tag tag_number
--shortname short_group_name --longname <"long_group_name">
[--parentname parent_group_name]
[ -b admin_context ] -h OID_host [-p port] -D bind_DN -w bind_password
```

Example

```
olsadmintool creategroup --polname defense --tag 55 --shortname US
--longname "United States" -h sales_west -D cn=defense_admin -w bind_password
```

olsadmintool createlabel

The `olsadmintool createlabel` command creates a valid data label.

You must provide the policy name, the numeric tag of the label to be created, and the character string representation of the label.

Syntax

```
olsadmintool createlabel --polname policy_name --tag tag_number  
--value label_value  
[ -b admin_context ] -h OID_host [-p port] -D bind_DN -w bind_password
```

Example

```
olsadmintool createlabel --polname defense --tag 100 --value "TS:A,B:US,CA"  
-h sales_west -D cn=defense_admin -w bind_password
```

olsadmintool createlevel

The `olsadmintool createlevel` command creates a new level component.

You must provide the name of the policy, the tag numeric value, the short name of the level, and the long name of the level.

Syntax

```
olsadmintool createlevel --polname policy_name --tag tag_number  
--shortname short_level_name --longname <"long_level_name">  
[ -b admin_context ] -h OID_host [-p port] -D bind_DN -w bind_password
```

Example

```
olsadmintool createlevel --polname defense --tag 100 --shortname TS  
--longname "TOP SECRET" -h sales_west -D cn=defense_admin -w bind_password
```

olsadmintool createprofile

The `olsadmintool createprofile` command creates a new profile.

You must provide the policy name, the profile name, and either privileges, labels, or both privileges and labels. (A user profile can have either null label information or null privilege information, but not both null at the same time.) For labels, specify the maximum label users in this profile can use to read data, the maximum label users in this profile can use to write data, the minimum label users in this profile can use to write data, the default label for reading, the default row label for writing. For privileges, enclose in quotation markets list of privileges, separated by commas, for members of this profile.

Syntax

```
olsadmintool createprofile --polname policy_name --profname profile_name  
--maxreadlabel max_read_label --maxwritelabel max_write_label  
--minwritelabel min_read_label --defreadlabel default_read_label  
--defrowlabel default_row_label --privileges privileges_separated_by_comma  
[ -b admin_context ] -h OID_host [-p port] -D bind_DN -w bind_password
```

Example

```
olsadmintool createprofile --polname topsecret --profname topsales  
--maxreadlabel "TS:A,B:US,CA" --maxwritelabel "TS:A,B:US,CA"  
--minwritelabel "C" --defreadlabel "TS:A,B:US,CA"  
--defrowlabel "C:A,B:US,CA"  
--privileges "READ,COMPACCESS,WRITEACROSS"  
-b EDS -h ford -p 1890 -D cn=lbacsys -w lbacsyspwd
```

olsadmintool createpolicy

The `olsadmintool createpolicy` command creates a policy.

You must provide the name of the policy, the name of its label column, and the options.

Syntax

```
olsadmintool createpolicy --name policy_name --colname column_name  
--options options_separated_by_commas  
[ -b admin_context ] -h OID_host [-p port] -D bind_DN -w bind_password
```

In this specification:

- *new_options* can be any combination of the following entries: INVERSE_GROUP, HIDE, LABEL_DEFAULT, LABEL_UPDATE, CHECK_CONTROL, READ_CONTROL, WRITE_CONTROL, INSERT_CONTROL, DELETE_CONTROL, UPDATE_CONTROL, ALL_CONTROL, NO_CONTROL

Example

```
olsadmintool createpolicy --name defense --colname defense_col  
--options "READ_CONTROL,UPDATE_CONTROL" -h sales_west -p 389 -D cn=defense_admin  
-w bind_password
```

olsamindtool describeprofile

The `olsadmintool describeprofile` command enables you to see the contents of a policy profile.

You must provide the policy name and the name of the profile.

Syntax

```
olsadmintool describeprofile --polname policy_name --profname profile_name  
[ -b admin_context ] -h OID_host [-p port] -D bind_DN -w bind_password
```

Example

```
olsadmintool describeprofile --polname defense --profname contractors  
-h sales_west -D cn=defense_admin -w bind_password
```

olsadmintool dropadmin

The `olsadmintool dropadmin` command removes an enterprise user from the administrative group of a policy.

This means that the user is no longer able to create, modify, or delete the specified policy's metadata. You must provide the policy name and the DN of the administrator to be removed from the administrative group.

Syntax

```
olsadmintool dropadmin --polname policy_name --adminDN admin_DN  
[ -b admin_context ] -h OID_host [-p port] -D bind_DN -w bind_password
```

Example

```
olsadmintool dropadmin --polname defense --adminDN "cn=scott,c=us"  
-h sales_west -D cn=lbacsys -w bind_password
```

olsadmintool dropcompartment

The `olsadmintool dropcompartment` command removes a compartment component.

You must provide the name of the policy and the short name of the compartment.

Syntax

```
olsadmintool dropcompartment --polname policy_name  
--shortname short_compartment_name  
[ -b admin_context ] -h OID_host [-p port] -D bind_DN -w bind_password
```

Example

```
olsadmintool dropcompartment --polname defense --shortname A  
-h sales_west -D cn=defense_admin -w bind_password
```

olsadmintool dropgroup

The `olsadmintool dropgroup` command removes a group component.

You must provide the policy name and the short group name.

Syntax

```
olsadmintool dropgroup --polname policy_name --shortname short_group_name  
[ -b admin_context ] -h OID_host [-p port] -D bind_DN -w bind_password
```

Example

```
olsadmintool dropgroup --polname defense --shortname US  
-h sales_west -D cn=defense_admin -w bind_password
```

olsadmintool droplabel

The `olsadmintool droplabel` command drops a label from the policy.

You must provide the policy name and the string representation of the label.

Syntax

```
olsadmintool droplabel --polname policy_name --value label_value  
-h OID_host [-p port] -D bind_DN -w bind_password
```

Example

```
olsadmintool droplabel --polname defense --value "TS:A:US"  
h sales_west -D cn=defense_admin -w bind_password
```

olsadmintool droplevel

The `olsadmintool droplevel` command removes a level component from a specified policy.

You must provide the name of the policy and the short name of the level.

Syntax

```
olsadmintool droplevel --polname policy_name --shortname short_level_name  
[ -b admin_context ] -h OID_host [-p port] -D bind_DN -w bind_password
```

Example

```
olsadmintool droplevel --polname defense --shortname TS  
-h sales_west -D cn=defense_admin -w bind_password
```

olsadmintool droppolicy

The `olsadmintool droppolicy` command drops a policy.

You must provide the name of the policy to be dropped. For directory-enabled installations of Oracle Label Security, refer to [Subscription of Policies in Directory-Enabled Label Security](#).

Syntax

```
olsadmintool droppolicy --name policy_name  
[ -b admin_context ] -h OID_host [-p port] -D bind_DN -w bind_password
```

Example

```
olsadmintool droppolicy --name defense -h sales_west -D cn=defense_admin -w  
bind_password
```

olsadmintool dropprofile

The `olsadmintool dropprofile` command removes the specified profile.

You must provide the policy name and the name of the profile to be dropped.

Note:

Dropping a profile removes the authorization on that policy for all the users in the dropped profile. The users will be unable to see data protected by that policy.

Syntax

```
olsadmintool dropprofile --polname policy_name --profname profile_name  
[ -b admin_context ] -h OID_host [-p port] -D bind_DN -w bind_password
```

Example

```
olsadmintool dropprofile --name defense --profname employees  
-h sales_west -D cn=defense_admin -w bind_password
```

olsadmintool droppolcreator

The `olsadmintool droppolcreator` command cancels the ability of the specified user to create policies.

You must provide the user's DN.

Syntax

```
olsadmintool droppolcreator --userdn user_DN  
[ -b admin_context ] -h OID_host [-p port] -D bind_DN -w bind_password
```

Example

```
olsadmintool droppolcreator --userdn "cn-scott,c=us"  
-b UA -h sales_west -p 1890 -D bind_DN -w bind_password
```

olsadmintool dropuser

The `olsadmintool dropuser` command drops a user from the specified profile in the specified policy.

You must provide the policy name, the name of the profile, and the DN of the user.

Syntax

```
olsadmintool dropuser --polname policy_name --profname profile_name  
--userdn enterprise_user_DN  
[ -b admin_context ] -h OID_host [-p port] -D bind_DN -w bind_password
```

Example

```
olsadmintool dropuser --polname defense --profname contractors  
--userdn "cn=hanssen,c=us" -h sales_west -D cn=defense_admin -w bind_password
```

olsadmintool --help

The `olsadmintool command_name -- help` command displays help information about the specified command.

Syntax

```
olsadmintool command_name --help
```

olsadmintool noaudit

The `olsadmintool noaudit` command cancels the audit options for a policy.

You must provide the policy name and the options that are no longer to be audited.

Syntax

```
olsadmintool noaudit --polname policy_name --options audit_option_name  
[ -b admin_context ] -h OID_host [-p port] -D bind_DN -w bind_password
```

In this specification:

- *audit_option_name* can be any combination of the following entries: APPLY, REMOVE, SET, PRIVILEGE

Example

```
olsadmintool noaudit --polname defense --options "APPLY,PRIVILEGES" -h sales_west  
-D cn=defense_admin -w bind_password
```

olsadmintool listprofile

The `olsadmintool listprofile` command to see a list of all profiles in a given policy.

You must provide the policy name.

Syntax

```
olsadmintool listprofile --polname policy_name  
[ -b admin_context ] -h OID_host [-p port] -D bind_DN -w bind_password
```

Example

```
olsadmintool listprofile --polname defense -b CIA  
-h sales_west -D cn=defense_admin -w bind_password
```

Relating Parameters to Commands for olsadmintool

You must follow a set of guidelines for using the `olsadmintool` parameters.

- [About Relating Parameters to Commands for olsadmintool](#)
All `olsadmintool` commands must specify connection parameters.
- [Summaries of olsadmintool Parameters](#)
The `olsadmintool` has parameters that to accommodate different categories of need, such as policies, administration, and auditing.

About Relating Parameters to Commands for olsadmintool

All `olsadmintool` commands must specify connection parameters.

These parameters include the OID host, the bind DN, the bind password, and optionally, the port through which the connection to Oracle Internet Directory is to be made. The default port is 389.

All `olsadmintool` commands may specify, as needed, the subscriber/administrative-context using the `-b` flag.

The fact that specifying a parameter is optional, such as a port or an administrative context, is shown by enclosing the parameter within brackets. The two most common examples are [`-b admin context`] and [`-p port`].

Because every command must specify a host, bind DN, and password, and may, if needed, also specify an administrative context, [Table C-2](#) uses the abbreviation **CON** to represent all of these connection parameters as a group:

```
[ -b admin_context ] h OID_host [-p port] -D bind_DN -w bind_password
```

Summaries of olsadmintool Parameters

The `olsadmintool` has parameters that to accommodate different categories of need, such as policies, administration, and auditing.

[Table C-2](#) summarizes the commands in several categories.

- **Policies:** creating, altering, or dropping policies or their components, that is, levels, groups, and compartments
- **Data labels:** creating, altering, or dropping them
- **Administrators and policy creators:** adding or dropping them
- **Users:** adding or dropping users from a profile
- **Auditing options:** setting the options for what to audit for a policy
- **Profiles:** creating, listing, describing, or dropping them
- **Default read or row labels:** setting them

In [Table C-2](#) and [Table C-3](#), the column headings show only the parameters, not the keywords that must precede them. For example, [Table C-2](#) shows `policyname` and `column-name` as parameters for the `createpolicy` command, without showing the keywords that must precede them (`--name` and `--colname`).

[Table C-2](#) explains the individual parameters that are used as column headings in the summaries of [Table C-2](#) and [Table C-3](#).

In all these tables:

- OptionsP means policy enforcement options, that is, any combination of the following entries, separated by a comma:

```
— INVERSE_GROUP
— HIDE
— LABEL_DEFAULT
— LABEL_UPDATE
— CHECK_CONTROL
— READ_CONTROL
— WRITE_CONTROL
— INSERT_CONTROL
— DELETE_CONTROL
— UPDATE_CONTROL
— ALL_CONTROL
— NO_CONTROL
```

- OptionsA means audit options, that is, any comma-separated combination of the following entries: SET, APPLY, REMOVE, OR PRIVILEGE.

Table C-2 Summary: olsadmintool Command Parameters

| Command Category | Commands & Parameters | - | - | - | - | - | - |
|---------------------------------|--------------------------------|--------------------|--------------------|-------------------|------------------|------------|--------------------|
| Policies | Command | policy name | column-name | optionsP | CON | - | - |
| a policy | olsadmintool createpolicy | Required | Required | Required | Required | - | - |
| a policy | olsadmintool alterpolicy | Required | Omitted | Required | Required | - | - |
| a policy | olsadmintool droppolicy | Required | Omitted | Omitted | Required | - | - |
| Within a Policy, Create: | Command | policy name | tag | short name | long name | CON | parent name |
| a level | olsadmintool createlevel | Required | Required | Required | Required | Required | Omitted |
| a group | olsadmintool creategroup | Required | Required | Required | Required | Required | [Required] |
| a compartment | olsadmintool createcompartment | Required | Required | Required | Required | Required | Omitted |
| Within a Policy, Alter: | Command | - | - | - | - | - | - |
| a level | olsadmintool alterlevel | Required | Omitted | Unused | Unused | Unused | Omitted |
| a group or group parent | olsadmintool altergroup | Required | Omitted | Required | Required | Required | Omitted |
| a group or group parent | olsadmintool altergroupparent | Required | Omitted | Required | Omitted | Required | [Required] |
| a group or group parent | Command | policy name | tag | short name | long name | CON | parent name |
| a compartment | olsadmintool altercompartment | Required | Omitted | Required | Required | Required | Omitted |
| Within a Policy, Drop: | Command | - | - | - | - | - | - |
| level | olsadmintool droplevel | Required | Omitted | Required | Omitted | Required | Omitted |
| group | olsadmintool dropgroup | Required | Omitted | Required | Omitted | Required | Omitted |
| compartment | olsadmintool dropcompartment | Required | Omitted | Required | Omitted | Required | Omitted |
| Data Labels | Command | policy name | tag | value | CON | - | - |
| Create label | olsadmintool createlabel | Required | Required | Required | Required | - | - |
| Alter data label | olsadmintool alterlabel | Required | Required | Required | Required | - | - |

Table C-2 (Cont.) Summary: olsadmintool Command Parameters

| Command Category | Commands & Parameters | - | - | - | - | - | - |
|------------------------------|---|--------------------|---------------------|---------------|----------------|------------|----------|
| Drop data label | olsadmintool droplabel | Required | Omitted | Required | Required | - | - |
| Policy Administrators | Command | policy name | userDN | CON | - | - | - |
| Add an Admin | olsadmintool addadmin | Required | Required | Required | - | - | - |
| Drop an Admin | olsadmintool dropadmin | Required | Required | Required | - | - | - |
| Policy Creation | olsadmintool addpolcreator | Omitted | Required | Required | - | - | - |
| Policy Creation | olsadmintool dropolcreator | Omitted | Required | Required | - | - | - |
| Users | Command | policy name | profile name | userDN | CON | - | - |
| add a user | olsadmintool adduser | Required | Required | Required | Required | - | - |
| drop a user | olsadmintool dropuser | Required | Required | Required | Required | - | - |
| Auditing | olsadmintool audit | Required | optionsA | type | success | CON | - |
| auditing | olsadmintool noaudit | Required | Required | Required | Required | Required | Required |
| Help on olsadmintool | olsadmintool <i>command_name</i> -- help | Omitted | Omitted | Omitted | Omitted | Omitted | - |

Table C-3 Summary of Profile and Default Command Parameters

| Profile Action | Profile Command | Policy Name | Profile Name | Max Read Label | Max Write Label | Min Write Label | Def Read Label | Def Row Label | Priv's | CON |
|-------------------------------|-------------------------------|-------------|--------------|----------------|-----------------|-----------------|----------------|---------------|----------|----------|
| Create a Profile ¹ | olsadmintool createprofile | Required | Required | Required | Required | Required | Required | Required | Required | Required |
| List Profiles | olsadmintool list profile | Required | Omitted | Omitted | Omitted | Omitted | Omitted | Omitted | Omitted | Required |
| Describe a Profile | olsadmintool describe profile | Required | Required | Omitted | Omitted | Omitted | Omitted | Omitted | Omitted | Required |
| Drop a Profile | olsadmintool drop profile | Required | Required | Omitted | Omitted | Omitted | Omitted | Omitted | Omitted | Required |

¹ In createprofile, specifying both privileges and labels is not required: a profile can specify labels, privileges, or both.

Examples of Using the olsadmintool Utility

You use the `olsadmintool` commands to set up Oracle Label Security in an Oracle Internet Directory environment.

Each command appears in this listing on multiple lines for readability, but in reality, would be given out as a single long string on the command line. The summarized results of carrying out all these commands appear in [Results of These Examples](#), which follows the last example.

- [Example: Making Other Users Policy Creators](#)
The `olsadmintool addpolcreator` command can enable other users to be policy creators.
- [Example: Creating Policies with Valid Options](#)
The `olsadmintool createpolicy` command can create policies.
- [Example: Creating Policy Administrators](#)
The `olsadmintool addadmin` command can create policy administrators.
- [Example: Creating Levels](#)
The `olsadmintool createlevel` command can create individual levels.
- [Example: Creating Compartments](#)
The `olsadmintool createcompartment` command can create a compartment.
- [Example: Creating Groups](#)
The `olsadmintool creategroup` can create a group.
- [Example: Creating Labels](#)
The `olsadmintool createlabel` can create a label.
- [Example: Creating a Profile](#)
The `olsadmintool createprofile` command can create a profile.
- [Example: Adding a User to a Profile](#)
The `olsadmintool adduser` command can add a user to a profile.
- [Example: Adding Another User to a Profile](#)
You can use the `olsadmintool adduser` command to add another user to a profile.
- [Example: Setting Audit Options](#)
The `olsadmintool audit` command can set audit options in a non-unified auditing environment.
- [Results of These Examples](#)
As a result of running the sets of `olsadmintool` commands, the sample Oracle Label Security site has a specific structure.

Example: Making Other Users Policy Creators

The `olsadmintool addpolcreator` command can enable other users to be policy creators.

```
ORACLE_HOME/bin/olsadmintool addpolcreator --userdn "cn=psmith,c=us"  
-b "ou=Americas,o=Oracle,c=US" -h sales_west -p 389 -D "cn=lbacsys,c=us" -w  
bind_password
```

Example: Creating Policies with Valid Options

The `olsadmintool createpolicy` command can create policies.

```
ORACLE_HOME/bin/olsadmintool createpolicy --name Policy1 --colname pol1
--options READ_CONTROL,WRITE_CONTROL -b "ou=Americas,o=Oracle,c=US"
-h sales_west -p 389 -D "cn=psmith,c=us" -w bind_password
```

```
ORACLE_HOME/bin/olsadmintool createpolicy --name Policy2 --colname pol2
--options READ_CONTROL -b "ou=Americas,o=Oracle,c=US"
-h sales_west -p 389 -D "cn=lbacsys,c=us" -w bind_password
```

Example: Creating Policy Administrators

The `olsadmintool addadmin` command can create policy administrators.

```
ORACLE_HOME/bin/olsadmintool addadmin --polname Policy1
--adminidn "cn=shwong,c=us" -b "ou=Americas,o=Oracle,c=US" -h sales_west -p 389
-D "cn=psmith,c=us" -w bind_password
```

```
ORACLE_HOME/bin/olsadmintool addadmin --polname Policy2
--adminidn "cn=shwong,c=us" -b "ou=Americas,o=Oracle,c=US" -h sales_west -p 389
-D "cn=lbacsys,c=us" -w bind_password
```

Example: Creating Levels

The `olsadmintool createlevel` command can create individual levels.

```
ORACLE_HOME/bin/olsadmintool createlevel --polname Policy1 --tag 100
--shortname TS --longname "TOP SECRET" -b "ou=Americas,o=Oracle,c=US"
-h sales_west -p 389 -D "cn=shwong,c=us" -w bind_password
```

```
ORACLE_HOME/bin/olsadmintool createlevel --polname Policy1 --tag 99
--shortname S --longname SECRET -b "ou=Americas,o=Oracle,c=US"
-h sales_west -p 389 -D "cn=shwong,c=us" -w bind_password
```

```
ORACLE_HOME/bin/olsadmintool createlevel --polname Policy1 --tag 98
--shortname U --longname UNCLASSIFIED -b "ou=Americas,o=Oracle,c=US"
-h sales_west -p 389 -D "cn=shwong,c=us" -w bind_password
```

Example: Creating Compartments

The `olsadmintool createcompartment` command can create a compartment.

```
ORACLE_HOME/bin/olsadmintool createcompartment --polname Policy1 --tag 100
--shortname A --longname ALPHA -b "ou=Americas,o=Oracle,c=US"
-h sales_west -p 389 -D "cn=shwong,c=us" -w bind_password
```

```
ORACLE_HOME/bin/olsadmintool createcompartment --polname Policy1 --tag 99
--shortname B --longname BETA -b "ou=Americas,o=Oracle,c=US"
-h sales_west -p 389 -D "cn=shwong,c=us" -w bind_password
```

Example: Creating Groups

The `olsadmintool creategroup` can create a group.

```
ORACLE_HOME/bin/olsadmintool creategroup --polname Policy1 --tag 100
--shortname G1 --longname GROUP1
-b "ou=Americas,o=Oracle,c=US" -h sales_west -p 389 -D "cn=shwong,c=us" -w
bind_password
```

```
ORACLE_HOME/bin/olsadmintool creategroup --polname Policy1 --tag 99
--shortname G2 --longname GROUP2
-b "ou=Americas,o=Oracle,c=US" -h sales_west -p 389 -D "cn=shwong,c=us" -w
bind_password
```

```
ORACLE_HOME/bin/olsadmintool creategroup --polname Policy1 --tag 98
--shortname G3 --longname GROUP3
-b "ou=Americas,o=Oracle,c=US" -h sales_west -p 389 -D "cn=shwong,c=us" -w
bind_password
```

Example: Creating Labels

The `olsadmintool createlabel` can create a label.

```
ORACLE_HOME/bin/olsadmintool createlabel --polname Policy1
--tag 100 --value TS:A:G1
-b "ou=Americas,o=Oracle,c=US" -h sales_west -p 389 -D "cn=shwong,c=us" -w
bind_password
```

```
ORACLE_HOME/bin/olsadmintool createlabel --polname Policy1 --tag 101
--value TS:A,B:G2
-b "ou=Americas,o=Oracle,c=US" -h sales_west -p 389 -D "cn=shwong,c=us" -w
bind_password
```

Example: Creating a Profile

The `olsadmintool createprofile` command can create a profile.

```
ORACLE_HOME/bin/olsadmintool createprofile --polname Policy1 --profname Profile1
--maxreadlabel TS:A:G1 --maxwritelabel TS:A:G1 --minwritelabel U::
--defreadlabel U:A:G1 --defrowlabel U:A:G1 --privileges WRITEUP,READ
-b "ou=Americas,o=Oracle,c=US" -h sales_west -p 389 -D "cn=shwong,c=us" -w
bind_password
```

Example: Adding a User to a Profile

The `olsadmintool adduser` command can add a user to a profile.

```
ORACLE_HOME/bin/olsadmintool adduser --polname Policy1 --profname Profile1
--userdn cn=nina,ou=Asia,o=microsoft,l=seattle,st=WA,c=US
-b "ou=Americas,o=Oracle,c=US" -h sales_west -p 389 -D "cn=shwong,c=us" -w
bind_password
```

Example: Adding Another User to a Profile

You can use the `olsadmintool adduser` command to add another user to a profile.

```
ORACLE_HOME/bin/olsadmintool adduser --polname Policy1 --profname Profile1
--userdn cn=daniel,ou=France,o=oracle,l=madison,st=WI,c=US
-b "ou=Americas,o=Oracle,c=US" -h sales_west -p 389 -D "cn=shwong,c=us" -w
bind_password
```

Example: Setting Audit Options

The `olsadmintool audit` command can set audit options in a non-unified auditing environment.

```
ORACLE_HOME/bin/olsadmintool audit --polname Policy1 --option "SET,APPLY"
--type SESSION --success BOTH
-b "ou=Americas,o=Oracle,c=US" -h sales_west -p 389 -D "cn=shwong,c=us" -w
bind_password
```

Results of These Examples

As a result of running the sets of `olsadmintool` commands, the sample Oracle Label Security site has a specific structure.

- **Policy creators:** User `psmith`
- **Policies:** `Policy1` and `Policy2`
- **Policy Administrators:** User `shwong`
- **Levels, Compartments, and Groups:** Refer to [Table C-4](#).

Table C-4 Label Component Definitions from Using `olsadmintool` Commands

| Label Component | Tag | Short Name | Long Name |
|-----------------|-----|------------|--------------|
| Level | 100 | TS | TOP SECRET |
| Level | 99 | S | SECRET |
| Level | 98 | U | UNCLASSIFIED |
| Compartment | 100 | A | ALPHA |
| Compartment | 99 | B | BETA |
| Group | 100 | G1 | GROUP1 |
| Group | 99 | G2 | GROUP2 |
| Group | 98 | G3 | GROUP3 |

- **Data labels:** Tag 100 for TS:A:G1 and tag 101 for TS:A,B:G2
- **Users:** Nina, from the Asia group of Microsoft, based in Seattle, Washington, managed under the Americas organization of the US Oracle organization, and Daniel, from the France group of Oracle in Madison, Wisconsin, managed under the same organization.
- **Profiles:** Refer to [Table C-5](#).

Table C-5 Contents of Profile1 from Using olsadmintool Commands

| Profile Element | Contents | Long-name Expansion or Meaning |
|-----------------|----------------|--|
| MaxReadLabel | TS:A:G1 | TOP SECRET:ALPHA:GROUP1 |
| MaxWriteLabel | TS:A:G1 | TOP SECRET:ALPHA:GROUP1 |
| MinWriteLabel | U:: | UNCLASSIFIED (not restricted to any compartments or groups) |
| DefReadLabel | U:A:G1 | UNCLASSIFIED:ALPHA:GROUP1 |
| DefRowLabel | U:A:G1 | UNCLASSIFIED:ALPHA:GROUP1 |
| Privileges | WRITE_UP, READ | User can read any row and raise the level of rows the user writes. |

- **Auditing options:** SET, APPLY, SESSION, and BOTH

D

Oracle Label Security in an Oracle RAC Environment

You can use Oracle Label Security in an Oracle Real Application Clusters (Oracle RAC) environment.

- [Oracle Label Security Policy Functions in an Oracle RAC Environment](#)
Policy changes made on one instance are available to other instances in the Oracle Real Application Clusters (Oracle RAC) environment immediately.
- [Transparent Application Failover in Oracle Label Security](#)
Session information is preserved on Transparent Application Failover.

Oracle Label Security Policy Functions in an Oracle RAC Environment

Policy changes made on one instance are available to other instances in the Oracle Real Application Clusters (Oracle RAC) environment immediately.

It is not necessary to restart the other instances to pick up the changes.

Important changes made on one database instance are automatically propagated to the other instances. One example would be creating a new policy. Another would be altering the policy options.

Propagating such changes ensures two valuable protections:

- That all users of the table are subject to the same policy
- That if any instance fails, continuation of its work by other instances will use the same policies and parameters that were in force immediately prior to that failure. So, if a policy had been enabled or disabled, it would be seen as such in all instances.

If an administrator changes policy information in one instance by using the policy functions listed in [Table D-1](#), Oracle Label Security stores the relevant information about whatever that function call changed. The new information is immediately available to the other active instances in the Oracle RAC, enabling uniformity among users of the affected policies.

Table D-1 Policy Functions Preserving Status in an Oracle RAC Environment

| Policy Functions | Description |
|--------------------------|-----------------------------|
| SA_SYSDBA.CREATE_POLICY | Creates a new policy |
| SA_SYSDBA.DROP_POLICY | Drops an existing policy |
| SA_SYSDBA.ENABLE_POLICY | Enables an existing policy |
| SA_SYSDBA.DISABLE_POLICY | Disables an existing policy |

Table D-1 (Cont.) Policy Functions Preserving Status in an Oracle RAC Environment

| Policy Functions | Description |
|------------------------|---------------------------|
| SA_SYSDBA.ALTER_POLICY | Alters an existing policy |

Transparent Application Failover in Oracle Label Security

Session information is preserved on Transparent Application Failover.

Any changes to the session's information by way of session functions listed in [Table D-2](#) are preserved on Transparent Application Failover.

For example, suppose a user `scott` is logged on with default label `Top Secret`. If he calls `sa_session.set_label()` to change his session label to `Secret`, and a failover to another instance occurs, he will see no change but his session label remains `Secret`.

Preserving current user session information means that the access permissions and restrictions on what data that user can see or affect remain as they were. Despite the failover, the user can see and affect only the tables and rows accessible before the failover. If preservation were not the case, failing over to another instance could cause or enable the user to see a different set of data.

Whenever one of the session functions listed in [Table D-2](#) is used, Oracle Label Security stores the relevant information about whatever was changed by that function call.

Table D-2 Session Functions Preserving Status in an Oracle RAC Environment

| Session Functions | Description |
|-----------------------------------|---|
| SA_SESSION.SET_LABEL | Lets the user set a new level and new compartments and groups to which he or she has read access |
| SA_SESSION.SET_ROW_LABEL | Lets the user set the default row label that will be applied to new rows |
| SA_SESSION.SAVE_DEFAULT_LABELS | Lets the user store the current session label and row label as the default for future sessions |
| SA_SESSION.RESTORE_DEFAULT_LABELS | Lets the user reset the current session label and row label to the stored default settings |
| SA_SESSION.SET_ACCESS_PROFILE | Sets the Oracle Label Security authorizations and privileges of the database session to those of the specified user |

E

Oracle Label Security PL/SQL Packages

Oracle Label Security provides a set of PL/SQL packages.

- [SA_AUDIT_ADMIN Oracle Label Security Auditing PL/SQL Package](#)
For a non-unified auditing environment, the `SA_AUDIT_ADMIN` PL/SQL package configures auditing that is specific to Oracle Label Security.
- [SA_COMPONENTS Label Components PL/SQL Package](#)
The `SA_COMPONENTS` PL/SQL package manages the component definitions of an Oracle Label Security label.
- [SA_LABEL_ADMIN Label Management PL/SQL Package](#)
The `SA_LABEL_ADMIN` PL/SQL package provides an administrative interface to manage the labels used by a policy.
- [SA_POLICY_ADMIN Policy Administration PL/SQL Package](#)
The `SA_POLICY_ADMIN` PL/SQL package manages Oracle Label Security policies as a whole.
- [SA_SESSION Session Management PL/SQL Package](#)
The `SA_SESSION` PL/SQL package manages session behavior for user authorizations.
- [SA_SYSDBA Policy Management PL/SQL Package](#)
The `SA_SYSDBA` PL/SQL package manages Oracle Label Security policies.
- [SA_USER_ADMIN PL/SQL Package](#)
The `SA_USER_ADMIN` PL/SQL package manages user labels by label component.
- [SA_UTL PL/SQL Utility Functions and Procedures](#)
The `SA_UTL` PL/SQL package contains utility functions and procedures that are used in PL/SQL programs.



See Also:

[Using Dominance Functions](#) for additional standalone Oracle Label Security functions

SA_AUDIT_ADMIN Oracle Label Security Auditing PL/SQL Package

For a non-unified auditing environment, the `SA_AUDIT_ADMIN` PL/SQL package configures auditing that is specific to Oracle Label Security.

- [About the SA_AUDIT_ADMIN PL/SQL Package](#)
The `SA_AUDIT_ADMIN` PL/SQL package configures auditing for labels and policies, as well as creating an auditing-related view.

- [SA_AUDIT_ADMIN.AUDIT](#)
The `SA_AUDIT_ADMIN.AUDIT` procedure enables policy-specific auditing.
- [SA_AUDIT_ADMIN.AUDIT_LABEL](#)
The `SA_AUDIT_ADMIN.AUDIT_LABEL` procedure records policy labels during auditing.
- [SA_AUDIT_ADMIN.AUDIT_LABEL_ENABLED](#)
The `SA_AUDIT_ADMIN.AUDIT_LABEL_ENABLED` function shows whether labels are being recorded in audit records for the policy.
- [SA_AUDIT_ADMIN.CREATE_VIEW](#)
The `SA_AUDIT_ADMIN.CREATE_VIEW` procedure creates an audit trail view named `DBA_policyname_AUDIT_TRAIL`.
- [SA_AUDIT_ADMIN.DROP_VIEW](#)
The `SA_AUDIT_ADMIN.DROP_VIEW` procedure drops the audit trail view for the specified policy.
- [SA_AUDIT_ADMIN.NOAUDIT](#)
The `SA_AUDIT_ADMIN.NOAUDIT` procedure disables Oracle Label Security policy-specific auditing.
- [SA_AUDIT_ADMIN.NOAUDIT_LABEL](#)
The `SA_AUDIT_ADMIN.NOAUDIT_LABEL` procedure disables the auditing of policy labels.

About the SA_AUDIT_ADMIN PL/SQL Package

The `SA_AUDIT_ADMIN` PL/SQL package configures auditing for labels and policies, as well as creating an auditing-related view.

If you are using unified auditing, then see *Oracle Database Security Guide* for information about creating unified audit policies for Oracle Label Security. In a unified auditing environment, no new audit records will be generated as a result of setting the procedures that are described in this section.

After you have enabled systemwide auditing, you can use `SA_AUDIT_ADMIN` PL/SQL package procedures to enable or disable Oracle Label Security auditing. To use this package, you must be granted the `policy_DBA` role (for example, `HR_OLS_POL_DBA` for a role for the `hr_ols_pol` policy) and the `EXECUTE` privilege for the `SA_AUDIT_ADMIN` package.



See Also:

[Duties of Oracle Label Security Administrators](#) for information about the `policy_DBA` role

SA_AUDIT_ADMIN.AUDIT

The `SA_AUDIT_ADMIN.AUDIT` procedure enables policy-specific auditing.

Auditing of each policy is independent of the others. The audit records capture Oracle Label Security administrative actions and the use of Oracle Label Security privileges that were used during logons, DML executions, and trusted stored procedure invocations.

Syntax

```
SA_AUDIT_ADMIN.AUDIT (
  policy_name    IN VARCHAR2,
  users          IN VARCHAR2 DEFAULT NULL,
  audit_option   IN VARCHAR2 DEFAULT NULL,
  audit_type     IN VARCHAR2 DEFAULT NULL,
  success        IN VARCHAR2 DEFAULT NULL);
```

Parameters

Table E-1 SA_AUDIT_ADMIN.AUDIT Parameters

| Parameter | Description |
|--------------|---|
| policy_name | Specifies the policy. To find existing policies, query the <code>POLICY_NAME</code> column of the <code>ALL_SA_POLICIES</code> data dictionary view. |
| users | Optional. A comma-delimited list of user names to audit, as follows: <ul style="list-style-type: none"> If you are auditing OLS administrative actions, then ensure that the users you enter have the <code>policy_DBA</code> role and the <code>EXECUTE</code> privilege for the Oracle Label Security packages. If you are auditing the use of OLS privileges, then these users do not need to be OLS administrators. If you do not specify any users, then all users are audited. To find users who have privileges to modify Oracle Label Security policies, query the <code>USER_NAME</code> column of the <code>DBA_SA_USERS</code> view. |
| audit_option | Optional. A comma-delimited list of options to be audited. Options are as follows: <ul style="list-style-type: none"> <code>APPLY</code>: Audits application of specified Oracle Label Security policies to tables and schemas <code>REMOVE</code>: Audits removal of specified Oracle Label Security policies from tables and schemas <code>SET</code>: Audits the setting of user authorizations, and user and program privileges <code>PRIVILEGES</code>: Audits use of all policy-specific privileges If not specified, then all default options (that is, options not including privileges) are audited. Audit options for privileged operations should be set explicitly by specifying the <code>PRIVILEGES</code> option, which sets audit options for all privileges. |
| audit_type | Optional. <code>BY ACCESS</code> or <code>BY SESSION</code> . If not specified, then audit records are written <code>BY SESSION</code> . |
| success | Optional. <code>SUCCESSFUL</code> if the action was successful, or <code>NOT SUCCESSFUL</code> . If not specified, then audit is written for both. |

Examples

The following example audits any failed `APPLY` and `REMOVE` attempts by the users `psmith` and `rlayton`.

```
BEGIN
  SA_AUDIT_ADMIN.AUDIT(
    policy_name => 'hr_ols_pol',
    users       => 'jjones, rlayton',
    audit_option => 'apply, remove',
    audit_type  => 'by access',
```

```

    success          => 'not successful');
END;
/

```

If you do not specify any audit options, then all options except the privilege-related ones are audited. You must specify the auditing of privileges explicitly. For example, if you enter the following statement, then the default options are set for the `hr_ols_pol` policy:

```
EXEC SA_AUDIT_ADMIN.AUDIT ('hr_ols_pol');
```

When you enable auditing, it will be performed on all users by session, whether their actions are successful or not.

When you set auditing parameters and options, the new values apply only to subsequent sessions, not to the current session.

Consider also a case in which one `SA_AUDIT_ADMIN.AUDIT` call (with no users specified) enables auditing for `APPLY` operations for all users, and then a second call enables auditing of `REMOVE` operations for a specific user. For example:

```
EXEC SA_AUDIT_ADMIN.AUDIT ('hr_ols_pol', null, 'apply');
EXEC SA_AUDIT_ADMIN.AUDIT ('hr_ols_pol', 'scott', 'remove');
```

In this case, `SCOTT` is audited for both `APPLY` and `REMOVE` operations.

SA_AUDIT_ADMIN.AUDIT_LABEL

The `SA_AUDIT_ADMIN.AUDIT_LABEL` procedure records policy labels during auditing.

This procedure stores the user's session label in the audit table.

Syntax

```
SA_AUDIT_ADMIN.AUDIT_LABEL (
    policy_name      IN VARCHAR2);
```

Parameter

Table E-2 SA_AUDIT_ADMIN.AUDIT_LABEL Parameter

| Parameter | Description |
|--------------------------|--|
| <code>policy_name</code> | Specifies the policy. To find existing policies, query the <code>POLICY_NAME</code> column of the <code>ALL_SA_POLICIES</code> data dictionary view. |

Example

The following example writes output indicating whether the Oracle Label Security labels are being audited for the `hr_ols_pol` policy.

```

BEGIN
  SA_AUDIT_ADMIN.AUDIT_LABEL(
    policy_name      => 'hr_ols_pol');
END;
/

```

SA_AUDIT_ADMIN.AUDIT_LABEL_ENABLED

The `SA_AUDIT_ADMIN.AUDIT_LABEL_ENABLED` function shows whether labels are being recorded in audit records for the policy.

Syntax

```
SA_AUDIT_ADMIN.AUDIT_LABEL_ENABLED (
    policy_name IN VARCHAR2)
RETURN BOOLEAN;
```

Parameters

Table E-3 SA_AUDIT_ADMIN.AUDIT_LABEL_ENABLED Parameter

| Parameter | Description |
|--------------------------|--|
| <code>policy_name</code> | Specifies the policy. To find existing policies, query the <code>POLICY_NAME</code> column of the <code>ALL_SA_POLICIES</code> data dictionary view. |

Example

The following example writes output indicating whether the Oracle Label Security labels are being audited for the `hr_ols_pol` policy.

```
SET SERVEROUTPUT ON
BEGIN
    IF SA_AUDIT_ADMIN.AUDIT_LABEL_ENABLED('hr_ols_pol')
    THEN DBMS_OUTPUT.PUT_LINE('OLS hr_ols_pol labels are being audited.');
```

```
ELSE
    DBMS_OUTPUT.PUT_LINE('OLS hr_ols_pol labels not being audited.');
```

```
END IF;
END;
```

```
/
```

SA_AUDIT_ADMIN.CREATE_VIEW

The `SA_AUDIT_ADMIN.CREATE_VIEW` procedure creates an audit trail view named `DBA_policyname_AUDIT_TRAIL`.

This view contains the specified policy's label column as well as all the entries in the audit trail written on behalf of this policy. If the view name exceeds the database limit of 30 characters, then the user can optionally specify a shorter view name.

See Also:

[Oracle Label Security User-Created Auditing View](#) to find the columns that are contained in the `DBA_policyname_AUDIT_TRAIL` view

Syntax

```
SA_AUDIT_ADMIN.CREATE_VIEW (
    policy_name    IN VARCHAR2,
    view_name      IN VARCHAR2    DEFAULT NULL);
```

Parameters

Table E-4 SA_AUDIT_ADMIN.CREATE_VIEW Parameters

| Parameter | Description |
|-------------|--|
| policy_name | Specifies the policy. To find existing policies, query the POLICY_NAME column of the ALL_SA_POLICIES data dictionary view. |
| view_name | Optional. Specifies the name of the view name. If you omit this setting, then the name defaults to DBA_policyname_AUDIT_TRAIL. |

Examples

The following example creates a view called hr_ols_pol_view for the hr_ols_pol policy.

```
BEGIN
  SA_AUDIT_ADMIN.CREATE_VIEW(
    policy_name    => 'hr_ols_pol',
    view_name      => 'hr_ols_pol_view');
END;
/
```

SA_AUDIT_ADMIN.DROP_VIEW

The SA_AUDIT_ADMIN.DROP_VIEW procedure drops the audit trail view for the specified policy.

Syntax

```
SA_AUDIT_ADMIN.DROP_VIEW (
    policy_name    IN VARCHAR2,
    view_name      IN VARCHAR2    DEFAULT NULL);
```

Parameters

Table E-5 SA_AUDIT_ADMIN.DROP_VIEW Parameters

| Parameter | Description |
|-------------|---|
| policy_name | Specifies the policy. To find existing policies, query the POLICY_NAME column of the ALL_SA_POLICIES data dictionary view. |
| view_name | Specifies an existing view's name. You can find this view by first querying the ALL_SA_POLICIES data dictionary view to find the name of the policy on which the view was based, and then querying ALL_VIEWS data dictionary view to find any views that have the name of the policy. |

Example

The following example drops the view called `hr_ols_pol_view` from the `hr_ols_pol` policy.

```
BEGIN
  SA_AUDIT_ADMIN.DROP_VIEW(
    policy_name => 'hr_ols_pol',
    view_name   => 'hr_ols_pol_view');
END;
/
```

SA_AUDIT_ADMIN.NOAUDIT

The `SA_AUDIT_ADMIN.NOAUDIT` procedure disables Oracle Label Security policy-specific auditing.

Syntax

```
SA_AUDIT_ADMIN.NOAUDIT (
  policy_name  IN VARCHAR2,
  users        IN VARCHAR2 DEFAULT NULL,
  audit_option IN VARCHAR2 DEFAULT NULL);
```

Parameters

Table E-6 SA_AUDIT_ADMIN.NO_AUDIT Parameters

| Parameter | Description |
|---------------------------|---|
| <code>policy_name</code> | Specifies the policy. To find existing policies, query the <code>POLICY_NAME</code> column of the <code>ALL_SA_POLICIES</code> data dictionary view. |
| <code>users</code> | Optional. A comma-delimited list of users who were audited. If not specified, then auditing is disabled for all users. To find users who have privileges to modify Oracle Label Security policies, query the <code>USER_NAME</code> column of the <code>ALL_SA_AUDIT_OPTIONS</code> view. |
| <code>audit_option</code> | Optional. A comma-delimited list of options to be disabled. Options are as follows: <ul style="list-style-type: none"> <code>APPLY</code>: Audits application of specified Oracle Label Security policies to tables and schemas <code>REMOVE</code>: Audits removal of specified Oracle Label Security policies from tables and schemas <code>SET</code>: Audits the setting of user authorizations, and user and program privileges <code>PRIVILEGES</code>: Audits use of all policy-specific privileges If not specified, then all default options are disabled. Privileges must be disabled explicitly. |

Examples

The following example disables auditing for failed `APPLY` and `REMOVE` attempts by the users `psmith` and `rlayton`.

```

BEGIN
  SA_AUDIT_ADMIN.NOAUDIT(
    policy_name      => 'hr_ols_pol',
    users            => 'jjones',
    audit_option     => 'apply, remove');
END;
/

```

You can disable auditing for all enabled options, or only for a subset of enabled options. All auditing for the specified options is disabled for all specified users (or all users, if the *users* parameter is `NULL`). For example, the following statement disables auditing of the `APPLY` and `REMOVE` operations for users John, Mary, and Scott:

```
EXEC SA_AUDIT_ADMIN.NOAUDIT ('HR', 'JOHN, MARY, SCOTT', 'APPLY, REMOVE');
```

Consider also a case in which one `AUDIT` call enables auditing for a specific user, and a second call (with no user specified) enables auditing for all users. For example:

```
EXEC SA_AUDIT_ADMIN.AUDIT ('HR', 'SCOTT');
EXEC SA_AUDIT_ADMIN.AUDIT ('HR');
```

In this case, a subsequent call to `NOAUDIT` with no users specified (such as the following statement) does not reverse the auditing that was set for `SCOTT` explicitly in the first call. So, auditing continues to be performed on `SCOTT`.

```
EXEC SA_AUDIT_ADMIN.NOAUDIT ('HR');
```

In this way, even if `SA_AUDIT_ADMIN.NOAUDIT` is set for all users, Oracle Label Security still audits any users for whom auditing was explicitly set.

Auditing of privileged operations must be specified explicitly. If you run `SA_AUDIT_ADMIN.NOAUDIT` with no options, the Oracle Label Security will nonetheless continue to audit privileged operations. For example, if auditing is enabled and you enter

```
EXEC SA_AUDIT_ADMIN.NOAUDIT ('HR');
```

then auditing will continue to be performed on the privileged operations (such as `WRITEDOWN`).

`SA_AUDIT_ADMIN.NOAUDIT` parameters and options that you set apply only to subsequent sessions, not to current sessions.

If you try to enable an audit option that has already been set, or if you try to disable an audit option that has not been set, then Oracle Label Security processes the statement without indicating an error. An attempt to specify an invalid option results in an error message. You can find the status of audit options by querying the `ALL_SA_AUDIT_OPTIONS` data dictionary view.

SA_AUDIT_ADMIN.NOAUDIT_LABEL

The `SA_AUDIT_ADMIN.NOAUDIT_LABEL` procedure disables the auditing of policy labels.

Syntax

```
SA_AUDIT_ADMIN.NOAUDIT_LABEL (
  policy_name      IN VARCHAR2);
```

Parameters

Table E-7 SA_AUDIT_ADMIN.NO_AUDIT_LABEL Parameter

| Parameter | Description |
|-------------|--|
| policy_name | Specifies the policy. To find existing policies, query the POLICY_NAME column of the ALL_SA_POLICIES data dictionary view. |

Example

The following example disables auditing for the hr_ols_pol policy.

```
BEGIN
  SA_AUDIT_ADMIN.NOAUDIT_LABEL(
    policy_name => 'hr_ols_pol');
END;
/
```

SA_COMPONENTS Label Components PL/SQL Package

The SA_COMPONENTS PL/SQL package manages the component definitions of an Oracle Label Security label.

- [About the SA_COMPONENTS PL/SQL Package](#)
The SA_COMPONENTS PL/SQL package configures compartments, groups, parent groups, and levels.
- [SA_COMPONENTS.ALTER_COMPARTMENT](#)
The SA_COMPONENTS.ALTER_COMPARTMENT procedure changes the short name and long name associated with a compartment.
- [SA_COMPONENTS.ALTER_GROUP](#)
The SA_COMPONENTS.ALTER_GROUP procedure changes the short name and long name associated with a group.
- [SA_COMPONENTS.ALTER_GROUP_PARENT](#)
The SA_COMPONENTS.ALTER_GROUP_PARENT procedure changes the parent group associated with a particular group.
- [SA_COMPONENTS.ALTER_LEVEL](#)
The SA_COMPONENTS.ALTER_LEVEL procedure changes the short name and long name associated with a level.
- [SA_COMPONENTS.CREATE_COMPARTMENT](#)
The SA_COMPONENTS.CREATE_COMPARTMENT procedure creates a compartment and specify its short name and long name.
- [SA_COMPONENTS.CREATE_GROUP](#)
The SA_COMPONENTS.CREATE_GROUP procedure creates a group and specify its short name and long name, and optionally a parent group.
- [SA_COMPONENTS.CREATE_LEVEL](#)
The SA_COMPONENTS.CREATE_LEVEL procedure creates a level and specify its short name and long name.
- [SA_COMPONENTS.DROP_COMPARTMENT](#)
The SA_COMPONENTS.DROP_COMPARTMENT procedure removes a compartment.

- [SA_COMPONENTS.DROP_GROUP](#)
The `SA_COMPONENTS.DROP_GROUP` procedure removes a group.
- [SA_COMPONENTS.DROP_LEVEL](#)
The `SA_COMPONENTS.DROP_LEVEL` procedure removes a level.

About the SA_COMPONENTS PL/SQL Package

The `SA_COMPONENTS` PL/SQL package configures compartments, groups, parent groups, and levels.

To use this package, you must be granted the `policy_DBA` role (for example, `HR_OLS_POL_DBA` for a role for the `hr_ols_pol` policy) and the `EXECUTE` privilege on the `SA_COMPONENTS` package.

Related Topics

- [Understanding Data Labels and User Labels](#)
You should understand fundamental concepts of data labels and user labels.

SA_COMPONENTS.ALTER_COMPARTMENT

The `SA_COMPONENTS.ALTER_COMPARTMENT` procedure changes the short name and long name associated with a compartment.

Once set, the `comp_num` parameter cannot be changed. If the `comp_num` parameter is used in any existing label, then its short name *cannot* be changed but its long name *can* be changed.

Syntax

```
SA_COMPONENTS.ALTER_COMPARTMENT (
    policy_name      IN VARCHAR2,
    comp_num         IN NUMBER(38),
    new_short_name   IN VARCHAR2,
    new_long_name    IN VARCHAR2);
```

```
SA_COMPONENTS.ALTER_COMPARTMENT (
    policy_name      IN VARCHAR2,
    short_name       IN VARCHAR2 DEFAULT NULL,
    new_long_name    IN VARCHAR2 DEFAULT NULL);
```

Parameters

Table E-8 SA_COMPONENTS.ALTER_COMPARTMENT Parameters

| Parameter | Description |
|--------------------------|--|
| <code>policy_name</code> | Specifies the policy. To find existing policies, query the <code>POLICY_NAME</code> column of the <code>ALL_SA_POLICIES</code> data dictionary view. |
| <code>comp_num</code> | Specifies the number of the compartment to be altered. To find a list of existing compartment numbers, query the <code>COMP_NUM</code> column of the <code>ALL_SA_COMPARTMENTS</code> view. |
| <code>short_name</code> | Specifies the short name of the compartment to be altered (up to 30 characters). To find the current compartment, query the <code>SHORT_NAME</code> column of the <code>ALL_SA_COMPARTMENTS</code> view. |

Table E-8 (Cont.) SA_COMPONENTS.ALTER_COMPARTMENT Parameters

| Parameter | Description |
|----------------|---|
| new_short_name | Specifies the new short name of the compartment (up to 30 characters) |
| new_long_name | Specifies the new long name of the compartment (up to 80 characters). |

Example

The following example modifies the `hr_ols_pol` policy.

```
BEGIN
  SA_COMPONENTS.ALTER_COMPARTMENT (
    policy_name      => 'hr_ols_pol',
    comp_num        => '48',
    new_short_name   => 'FIN',
    new_long_name    => 'FINANCE');
END;
/
```

SA_COMPONENTS.ALTER_GROUP

The `SA_COMPONENTS.ALTER_GROUP` procedure changes the short name and long name associated with a group.

Once set, the `group_num` parameter cannot be changed. If the group is used in any existing label, then its short name *cannot* be changed, but its long name *can* be changed.

Syntax

```
SA_COMPONENTS.ALTER_GROUP (
  policy_name  IN VARCHAR2,
  group_num    IN NUMBER(38),
  new_short_name IN VARCHAR2 DEFAULT NULL,
  new_long_name IN VARCHAR2 DEFAULT NULL);
```

```
SA_COMPONENTS.ALTER_GROUP (
  policy_name  IN VARCHAR2,
  short_name   IN VARCHAR2,
  new_long_name IN VARCHAR2);
```

Parameters**Table E-9 SA_COMPONENTS.ALTER_GROUP Parameters**

| Parameter | Description |
|-------------|--|
| policy_name | Specifies the policy. To find existing policies, query the <code>POLICY_NAME</code> column of the <code>ALL_SA_POLICIES</code> data dictionary view. |
| group_num | Specifies the existing group number to be altered. To find existing group numbers, query the <code>GROUP_NUM</code> column of the <code>ALL_SA_GROUPS</code> view. |

Table E-9 (Cont.) SA_COMPONENTS.ALTER_GROUP Parameters

| Parameter | Description |
|----------------|---|
| short_name | Specifies the existing group short name to be altered. To find existing short names, query the SHORT_NAME column of the ALL_SA_GROUPS view. |
| new_short_name | Specifies the new short name for the group (up to 30 characters) |
| new_long_name | Specifies the new long name for the group (up to 80 characters) |

Example

The following example modifies the long_name setting for the hr_ols_pol policy.

```
BEGIN
  SA_COMPONENTS.ALTER_GROUP (
    policy_name => 'hr_ols_pol',
    short_name  => 'ER_FIN',
    new_long_name => 'ER_FINANCES');
END;
/
```

SA_COMPONENTS.ALTER_GROUP_PARENT

The SA_COMPONENTS.ALTER_GROUP_PARENT procedure changes the parent group associated with a particular group.

Syntax

```
SA_COMPONENTS.ALTER_GROUP_PARENT (
  policy_name  IN VARCHAR2,
  group_num    IN NUMBER(38),
  new_parent_num IN NUMBER(38));
```

```
SA_COMPONENTS.ALTER_GROUP_PARENT (
  policy_name  IN VARCHAR2,
  group_num    IN NUMBER(38),
  new_parent_name IN VARCHAR2);
```

```
SA_COMPONENTS.ALTER_GROUP_PARENT (
  policy_name  IN VARCHAR2,
  short_name   IN VARCHAR2,
  new_parent_name IN VARCHAR2);
```

Parameters

Table E-10 SA_COMPONENTS.ALTER_GROUP_PARENT Parameters

| Parameter | Description |
|-------------|--|
| policy_name | Specifies the policy. To find existing policies, query the POLICY_NAME column of the ALL_SA_POLICIES data dictionary view. |
| group_num | Specifies the existing group number to be altered. To find existing group numbers, query the GROUP_NUM column of the ALL_SA_GROUPS view. |

Table E-10 (Cont.) SA_COMPONENTS.ALTER_GROUP_PARENT Parameters

| Parameter | Description |
|-----------------|---|
| short_name | Specifies the existing group short name to be altered. To find existing short names, query the SHORT_NAME column of the ALL_SA_GROUPS view. |
| new_parent_num | Specifies the number of an existing group as the parent group. To find existing parent groups, query the PARENT_NUM column of the ALL_SA_GROUPS view. |
| new_parent_name | Specifies the short name of an existing group as the parent group. To find existing groups, query the SHORT_NAME column of the ALL_SA_GROUPS view. |

Example

The following example modifies the parent name for the hr_ols_pol policy.

```
BEGIN
  SA_COMPONENTS.ALTER_GROUP_PARENT (
    policy_name      => 'hr_ols_pol',
    group_num        => 2100,
    new_parent_name  => 'ER');
END;
/
```

SA_COMPONENTS.ALTER_LEVEL

The SA_COMPONENTS.ALTER_LEVEL procedure changes the short name and long name associated with a level.

Once they are defined, level numbers cannot be changed. If a level is used in any existing label, then its short name *cannot* be changed, but its long name *can* be changed.

Syntax

```
SA_COMPONENTS.ALTER_LEVEL (
  policy_name      IN VARCHAR2,
  level_num        IN NUMBER(38),
  new_short_name   IN VARCHAR2 DEFAULT NULL,
  new_long_name    IN VARCHAR2 DEFAULT NULL);
```

```
SA_COMPONENTS.ALTER_LEVEL (
  policy_name      IN VARCHAR2,
  short_name       IN VARCHAR2,
  new_long_name    IN VARCHAR2);
```

Parameters

Table E-11 SA_COMPONENTS.ALTER_LEVEL Parameters

| Parameter | Description |
|----------------|--|
| policy_name | Specifies the policy, which must exist. To find existing policies, query the POLICY_NAME column of the ALL_SA_POLICIES data dictionary view. |
| level_num | Specifies the number of the level to be altered. To find existing levels, query the LEVEL_NUM column of the ALL_SA_LEVELS view. |
| short_name | Specifies the existing short name of the level. To find existing level short names, query the SHORT_NAME column of the ALL_SA_LEVELS view. |
| new_short_name | Specifies the new short name for the level (up to 30 characters) |
| new_long_name | Specifies the new long name for the level (up to 80 characters) |

Example

The following example modifies the short and long names for the hr_ols_pol policy level.

```
BEGIN
  SA_COMPONENTS.ALTER_LEVEL (
    policy_name => 'hr_ols_pol',
    level_num   => 40,
    new_short_name => 'TS',
    new_long_name => 'TOP_SECRET');
END;
/
```

SA_COMPONENTS.CREATE_COMPARTMENT

The SA_COMPONENTS.CREATE_COMPARTMENT procedure creates a compartment and specifies its short name and long name.

The comp_num parameter determines the order in which compartments are listed in the character string representation of labels.

Syntax

```
SA_COMPONENTS.CREATE_COMPARTMENT (
  policy_name IN VARCHAR2,
  comp_num    IN NUMBER(38),
  short_name  IN VARCHAR2,
  long_name   IN VARCHAR2);
```

Parameters

Table E-12 SA_COMPONENTS.CREATE_COMPARTMENT Parameters

| Parameter | Description |
|-------------|--|
| policy_name | Specifies the policy. To find existing policies, query the POLICY_NAME column of the ALL_SA_POLICIES data dictionary view. |
| comp_num | Specifies the compartment number (0-9999) |
| short_name | Specifies the short name for the compartment (up to 30 characters) |
| long_name | Specifies the long name for the compartment (up to 80 characters) |

Example

The following example creates a compartment for the `hr_ols_pol` policy.

```
BEGIN
  SA_COMPONENTS.CREATE_COMPARTMENT (
    policy_name => 'hr_ols_pol',
    comp_num   => '48',
    short_name  => 'FIN',
    long_name   => 'FINANCE');
END;
/
```

SA_COMPONENTS.CREATE_GROUP

The `SA_COMPONENTS.CREATE_GROUP` procedure creates a group and specify its short name and long name, and optionally a parent group.

Syntax

```
SA_COMPONENTS.CREATE_GROUP (
  policy_name IN VARCHAR2,
  group_num   IN NUMBER(38),
  short_name  IN VARCHAR2,
  long_name   IN VARCHAR2,
  parent_name IN VARCHAR2 DEFAULT NULL);
```

Parameters

Table E-13 SA_COMPONENTS.CREATE_GROUP Parameters

| Parameter | Description |
|-------------|--|
| policy_name | Specifies the policy. To find existing policies, query the POLICY_NAME column of the ALL_SA_POLICIES data dictionary view. |
| group_num | Specifies the group number (0-9999) |
| short_name | Specifies the short name for the group (up to 30 characters) |
| long_name | Specifies the long name for the group (up to 80 characters) |

Table E-13 (Cont.) SA_COMPONENTS.CREATE_GROUP Parameters

| Parameter | Description |
|-------------|--|
| parent_name | Specifies the short name of an existing group as the parent group. If NULL, then the group is a top-level group. |

Note that the group number affects the order in which groups will be displayed when labels are selected.

Examples

In the following examples, the first creates a parent group, ER, and the second creates a second group that is part of the parent group.

```
BEGIN
  SA_COMPONENTS.CREATE_GROUP (
    policy_name => 'hr_ols_pol',
    group_num   => 2000,
    short_name  => 'ER',
    long_name   => 'EAST_REGION');
END;
/
```

```
BEGIN
  SA_COMPONENTS.CREATE_GROUP (
    policy_name => 'hr_ols_pol',
    group_num   => 2100,
    short_name  => 'ER_FIN',
    long_name   => 'ER_FINANCES',
    parent_name => 'ER');
END;
/
```

SA_COMPONENTS.CREATE_LEVEL

The SA_COMPONENTS.CREATE_LEVEL procedure creates a level and specify its short name and long name.

The numeric values assigned to the level_num parameter determine the sensitivity ranking (that is, a lower number indicates less sensitive data).

Syntax

```
SA_COMPONENTS.CREATE_LEVEL (
  policy_name  IN VARCHAR2,
  level_num    IN NUMBER(38),
  short_name   IN VARCHAR2,
  long_name    IN VARCHAR2);
```

Parameters

Table E-14 SA_COMPONENTS.CREATE_LEVEL Parameters

| Parameter | Description |
|-------------|--|
| policy_name | Specifies the policy, which must exist. To find existing policies, query the POLICY_NAME column of the ALL_SA_POLICIES data dictionary view. |
| level_num | Specifies the level number (0-9999) |
| short_name | Specifies the short name for the level (up to 30 characters) |
| long_name | Specifies the long name for the level (up to 80 characters) |

Example

The following example creates a level for the hr_ols_pol policy.

```
BEGIN
  SA_COMPONENTS.CREATE_LEVEL (
    policy_name => 'hr_ols_pol',
    level_num   => 40,
    short_name  => 'HS',
    long_name   => 'HIGHLY_SENSITIVE');
END;
/
```

SA_COMPONENTS.DROP_COMPARTMENT

The SA_COMPONENTS.DROP_COMPARTMENT procedure removes a compartment.

If the compartment is used in any existing label, then it *cannot* be dropped. You can find all existing labels by querying the LABEL column of the ALL_SA_DATA_LABELS data dictionary view.

Syntax

```
SA_COMPONENTS.DROP_COMPARTMENT (
  policy_name IN VARCHAR2,
  comp_num    IN INTEGER);

SA_COMPONENTS.DROP_COMPARTMENT (
  policy_name IN VARCHAR2,
  short_name  IN VARCHAR2);
```

Parameters

Table E-15 SA_COMPONENTS.DROP_COMPARTMENT Parameters

| Parameter | Description |
|-------------|--|
| policy_name | Specifies the policy. To find existing policies, query the POLICY_NAME column of the ALL_SA_POLICIES data dictionary view. |

Table E-15 (Cont.) SA_COMPONENTS.DROP_COMPARTMENT Parameters

| Parameter | Description |
|------------|--|
| comp_num | Specifies the number of an existing compartment for the policy. To find existing compartment numbers, query the COMP_NUM column of the DBA_SA_COMPARTMENTS view. |
| short_name | Specifies the short name of an existing compartment for the policy. To find existing compartment short names, query the SHORT_NAME column of the DBA_SA_COMPARTMENTS view. |

Example

The following example removes the FIN compartment from the hr_ols_pol policy.

```
BEGIN
  SA_COMPONENTS.DROP_COMPARTMENT (
    policy_name => 'hr_ols_pol',
    short_name  => 'FIN');
END;
/
```

SA_COMPONENTS.DROP_GROUP

The SA_COMPONENTS.DROP_GROUP procedure removes a group.

If the group is used in an existing label, then it cannot be dropped.

Syntax

```
SA_COMPONENTS.DROP_GROUP (
  policy_name IN VARCHAR2,
  group_num   IN NUMBER(38));

SA_COMPONENTS.DROP_GROUP (
  policy_name IN VARCHAR2,
  short_name  IN VARCHAR2);
```

Parameters**Table E-16 SA_COMPONENTS.DROP_GROUP Parameters**

| Parameter | Description |
|-------------|---|
| policy_name | Specifies the policy. To find existing policies, query the POLICY_NAME column of the ALL_SA_POLICIES data dictionary view. |
| group_num | Specifies the number of an existing group for the policy. To find existing group numbers, query the GROUP_NUM column of the ALL_SA_GROUPS view. |
| short_name | Specifies the short name of an existing group. To find existing group short names, query the SHORT_NAME column of the ALL_SA_GROUPS view. |

Example

The following example removes a group based on the group number for the `hr_ols_pol` policy.

```

BEGIN
  SA_COMPONENTS.DROP_GROUP (
    policy_name => 'hr_ols_pol',
    group_num   => 2000);
END;
/

```

SA_COMPONENTS.DROP_LEVEL

The `SA_COMPONENTS.DROP_LEVEL` procedure removes a level.

If the level is used in any existing label, then it cannot be dropped.

Syntax

```

SA_COMPONENTS.DROP_LEVEL (
  policy_name IN VARCHAR2,
  level_num   IN NUMBER(38));

SA_COMPONENTS.DROP_LEVEL (
  policy_name IN VARCHAR2,
  short_name  IN VARCHAR2);

```

Parameters

Table E-17 SA_COMPONENTS.DROP_LEVEL Parameters

| Parameter | Description |
|--------------------------|--|
| <code>policy_name</code> | Specifies the policy, which must exist. To find existing policies, query the <code>POLICY_NAME</code> column of the <code>ALL_SA_POLICIES</code> data dictionary view. |
| <code>level_num</code> | Specifies the number of an existing level for the policy. To find existing level numbers, query the <code>LEVEL_NUM</code> column of the <code>ALL_SA_LEVELS</code> view. |
| <code>short_name</code> | Specifies the short name for the level (up to 30 characters). To find existing level short names, query the <code>SHORT_NAME</code> column of the <code>ALL_SA_LEVELS</code> view. |

Example

The following example drops the level 40 from the `hr_ols_pol` policy.

```

BEGIN
  SA_COMPONENTS.DROP_LEVEL (
    policy_name => 'hr_ols_pol',
    level_num   => 40);
END;
/

```

SA_LABEL_ADMIN Label Management PL/SQL Package

The SA_LABEL_ADMIN PL/SQL package provides an administrative interface to manage the labels used by a policy.

- [About the SA_LABEL_ADMIN PL/SQL Package](#)
The SA_LABEL_ADMIN PL/SQL package creates, alters, and deletes labels.
- [SA_LABEL_ADMIN.ALTER_LABEL](#)
The SA_LABEL_ADMIN.ALTER_LABEL procedure changes the character string label definition associated with a label tag.
- [SA_LABEL_ADMIN.CREATE_LABEL](#)
The SA_LABEL_ADMIN.CREATE_LABEL procedure creates data labels.
- [SA_LABEL_ADMIN.DROP_LABEL](#)
The SA_LABEL_ADMIN.DROP_LABEL procedure deletes a specified policy label.

About the SA_LABEL_ADMIN PL/SQL Package

The SA_LABEL_ADMIN PL/SQL package creates, alters, and deletes labels.

SA_LABEL_ADMIN.ALTER_LABEL

The SA_LABEL_ADMIN.ALTER_LABEL procedure changes the character string label definition associated with a label tag.

The label tag itself cannot be changed.

If you change the character string associated with a label tag, then the sensitivity of the data in the rows changes accordingly. For example, if the label character string TS:A with an associated label tag value of 4001 is changed to the label TS:B, then access to the data changes accordingly. This is true even when the label tag value (4001) has not changed. In this way, you can change the data's sensitivity without the need to update all the rows.

Ensure that when you specify a label to alter, you can refer to it either by its label tag or by its character string value.

Syntax

```
SA_LABEL_ADMIN.ALTER_LABEL (  
    policy_name      IN VARCHAR2,  
    label_tag        IN BINARY_INTEGER,  
    new_label_value  IN VARCHAR2 DEFAULT NULL,  
    new_data_label   IN BOOLEAN  DEFAULT NULL);
```

```
SA_LABEL_ADMIN.ALTER_LABEL (  
    policy_name      IN VARCHAR2,  
    label_value      IN VARCHAR2,  
    new_label_value  IN VARCHAR2 DEFAULT NULL,  
    new_data_label   IN BOOLEAN  DEFAULT NULL);
```

Parameters

Table E-18 SA_LABEL_ADMIN.ALTER_LABEL Parameters

| Parameter | Description |
|-----------------|--|
| policy_name | Specifies the name of an existing policy. To find existing policies, query the POLICY_NAME column of the ALL_SA_POLICIES data dictionary view. |
| label_tag | Identifies the integer tag assigned to the label to be altered. To find existing label tags, query the LABEL_TAG column of the ALL_SA_LABELS view. |
| label_value | Identifies the existing character string representation of the label to be altered. To find the existing label values, query the LABEL column of the ALL_SA_LABELS view. |
| new_label_value | Specifies the new character string representation of the label value. If NULL, the existing value is not changed. |
| new_data_label | TRUE if the label can be used to label row data. If NULL, the existing value is not changed. |

Example

The following example modifies the label_tag and label_value settings of hr_ols_pol policy.

```
BEGIN
  SA_LABEL_ADMIN.ALTER_LABEL (
    policy_name      => 'hr_ols_pol',
    label_tag        => 1111,
    new_label_value  => 'HS',
    new_data_label   => TRUE);
END;
/
```

SA_LABEL_ADMIN.CREATE_LABEL

The SA_LABEL_ADMIN.CREATE_LABEL procedure creates data labels.

Syntax

```
SA_LABEL_ADMIN.CREATE_LABEL (
  policy_name IN VARCHAR2,
  label_tag   IN BINARY_INTEGER,
  label_value IN VARCHAR2,
  data_label  IN BOOLEAN DEFAULT TRUE);
```

Parameters

Table E-19 SA_LABEL_ADMIN.CREATE_LABEL Parameters

| Parameter | Description |
|-------------|--|
| policy_name | Specifies the name of an existing policy. To find existing policies, query the POLICY_NAME column of the ALL_SA_POLICIES data dictionary view. |

Table E-19 (Cont.) SA_LABEL_ADMIN.CREATE_LABEL Parameters

| Parameter | Description |
|-------------|--|
| label_tag | Specifies a unique integer value representing the sort order of the label, relative to other policy labels (0-99999999). This value must be 1 to 8 digits long. |
| label_value | Specifies the character string representation of the label to be created. Use the short name of the level, compartment, and group. You can find these values by querying the SHORT_NAME column of the ALL_SA_LEVELS, ALL_SA_COMPARTMENTS, and ALL_SA_GROUPS views. |
| data_label | TRUE if the label can be used to label row data. Use this to define the label as valid for data. |

When you identify valid labels, you specify which of all the possible combinations of levels, compartments, and groups can potentially be used to label data in tables.

Example

The following example creates a label for the `hr_ols_pol` policy.

```
BEGIN
  SA_LABEL_ADMIN.CREATE_LABEL (
    policy_name    => 'hr_ols_pol',
    label_tag      => 1111,
    label_value    => 'HS:FIN',
    data_label     => TRUE);
END;
/
```



Note:

If you create a new label by using the `TO_DATA_LABEL` procedure, then a system-generated label tag of 10 digits is generated automatically.

However, when Oracle Label Security is installed to work with Oracle Internet Directory, dynamic label generation is not permitted, because labels are managed centrally in Oracle Internet Directory, using `olsadmintool` commands.

So, when Oracle Label Security is directory-enabled, the `TO_DATA_LABEL` function is not available and will generate an error message if used.

SA_LABEL_ADMIN.DROP_LABEL

The `SA_LABEL_ADMIN.DROP_LABEL` procedure deletes a specified policy label.

Any subsequent reference to the label (in data rows, or in user or program unit labels) will raise an invalid label error.

Use this procedure only while setting up labels, prior to data population. If you should inadvertently drop a label that is being used, you can recover it by disabling the policy, fixing the problem, and then re-enabling the policy.

Syntax

```
SA_LABEL_ADMIN.DROP_LABEL (
    policy_name      IN VARCHAR2,
    label_tag        IN BINARY_INTEGER);
```

```
SA_LABEL_ADMIN.DROP_LABEL (
    policy_name      IN VARCHAR2,
    label_value      IN VARCHAR2);
```

Parameters

Table E-20 SA_LABEL_ADMIN.DROP_LABEL Parameters

| Parameter | Description |
|-------------|---|
| policy_name | Specifies the name of an existing policy. To find existing policies, query the POLICY_NAME column of the ALL_SA_POLICIES data dictionary view. |
| label_tag | Specifies the integer tag assigned to the label to be dropped. To find existing label tags, query the LABEL_TAG column of the ALL_SA_LABELS view. |
| label_value | Specifies the string value of the label to be dropped. To find existing label values, query the LABEL column of the ALL_SA_LABELS view. |

⚠ WARNING:

Do not drop a label that is in use anywhere in the database. You can find labels by querying the ALL_SA_LABELS data dictionary view.

Example

The following example drops the hr_ols_pol policy label based on its label_tag setting.

```
BEGIN
    SA_LABEL_ADMIN.DROP_LABEL (
        policy_name => 'hr_ols_pol',
        label_tag   => 1111);
END;
/
```

SA_POLICY_ADMIN Policy Administration PL/SQL Package

The SA_POLICY_ADMIN PL/SQL package manages Oracle Label Security policies as a whole.

- [About the SA_POLICY_ADMIN PL/SQL Package](#)
The SA_POLICY_ADMIN PL/SQL package configures schema and table policies, and performs subscribe and unsubscribe actions.

- [SA_POLICY_ADMIN.ALTER_SCHEMA_POLICY](#)
The `SA_POLICY_ADMIN.ALTER_SCHEMA_POLICY` procedure changes the default enforcement options for the policy.
- [SA_POLICY_ADMIN.APPLY_SCHEMA_POLICY](#)
The `SA_POLICY_ADMIN.APPLY_SCHEMA_POLICY` procedure applies a policy to all of the tables in a schema and enables the policy for these tables.
- [SA_POLICY_ADMIN.APPLY_TABLE_POLICY](#)
The `SA_POLICY_ADMIN.APPLY_TABLE_POLICY` procedure adds the specified policy to a table.
- [SA_POLICY_ADMIN.DISABLE_SCHEMA_POLICY](#)
The `SA_POLICY_ADMIN.DISABLE_SCHEMA_POLICY` procedure disables the enforcement of the policy for all tables in a schema.
- [SA_POLICY_ADMIN.DISABLE_TABLE_POLICY](#)
The `SA_POLICY_ADMIN.DISABLE_TABLE_POLICY` procedure disables the enforcement of the policy for a table without changing the enforcement options, labeling function, or predicate values.
- [SA_POLICY_ADMIN.ENABLE_SCHEMA_POLICY](#)
The `SA_POLICY_ADMIN.ENABLE_SCHEMA_POLICY` procedure reenables the current enforcement options, labeling function, and predicate for the tables in the specified schema.
- [SA_POLICY_ADMIN.ENABLE_TABLE_POLICY](#)
The `SA_POLICY_ADMIN.ENABLE_TABLE_POLICY` procedure reenables the current enforcement options, labeling function, and predicate for the specified table.
- [SA_POLICY_ADMIN.POLICY_SUBSCRIBE](#)
In an Oracle Internet Directory-enabled Oracle Label Security configuration, the `SA_POLICY_ADMIN.POLICY_SUBSCRIBE` procedure subscribes to the policy for usage in `SA_POLICY_ADMIN.APPLY_TABLE_POLICY` and `SA_POLICY_ADMIN.APPLY_SCHEMA_POLICY`.
- [SA_POLICY_ADMIN.POLICY_UNSUBSCRIBE](#)
In an Oracle Internet Directory enabled Oracle Label Security configuration, the `SA_POLICY_ADMIN.POLICY_UNSUBSCRIBE` procedure unsubscribes to the policy.
- [SA_POLICY_ADMIN.REMOVE_SCHEMA_POLICY](#)
The `SA_POLICY_ADMIN.REMOVE_SCHEMA_POLICY` procedure removes the specified policy from a schema.
- [SA_POLICY_ADMIN.REMOVE_TABLE_POLICY](#)
The `SA_POLICY_ADMIN.REMOVE_TABLE_POLICY` procedure removes the specified policy from a table.

About the SA_POLICY_ADMIN PL/SQL Package

The `SA_POLICY_ADMIN` PL/SQL package configures schema and table policies, and performs subscribe and unsubscribe actions.

To use this package, you must be granted the `policy_DBA` role (for example, `HR_OLS_POL_DBA` for a role for the `hr_ols_pol` policy) and the `EXECUTE` privilege for the `SA_POLICY_ADMIN` package.

SA_POLICY_ADMIN.ALTER_SCHEMA_POLICY

The `SA_POLICY_ADMIN.ALTER_SCHEMA_POLICY` procedure changes the default enforcement options for the policy.

Any new tables created in the schema will automatically have the new enforcement options applied. The existing tables in the schema are not affected.

To change enforcement options on a table (rather than a schema), you must first drop the policy from the table, make the change, and then reapply the policy.

If you alter the enforcement options on a schema, then this will take effect the next time a table is created in the schema. As a result, different tables within a schema may have different policy enforcement options in force.

Syntax

```
SA_POLICY_ADMIN.ALTER_SCHEMA_POLICY (
  policy_name      IN VARCHAR2,
  schema_name     IN VARCHAR2,
  default_options  IN VARCHAR2);
```

Parameters

Table E-21 SA_POLICY_ADMIN.ALTER_SCHEMA Parameters

| Parameter | Description |
|------------------------------|---|
| <code>policy_name</code> | Specifies the policy. To find existing policies, query the <code>POLICY_NAME</code> column of the <code>ALL_SA_POLICIES</code> data dictionary view. |
| <code>schema_name</code> | The schema that contains the table. To find existing schemas associated with this policy, query the <code>POLICY_NAME</code> and <code>SCHEMA_NAME</code> columns of the <code>ALL_SA_TABLE_POLICIES</code> view. |
| <code>default_options</code> | The default options to be used for new tables in the schema. Separate each option with a comma. See Table 8-2 for a listing of the default enforcement options. |

Example

The following example adds the `UPDATE_CONTROL` default option to the `HR` schema.

```
BEGIN
  SA_POLICY_ADMIN.ALTER_SCHEMA_POLICY(
    policy_name => 'hr_ols_pol',
    schema_name => 'HR',
    default_options => 'read_control, write_control, update_control');
END;
/
```

SA_POLICY_ADMIN.APPLY_SCHEMA_POLICY

The `SA_POLICY_ADMIN.APPLY_SCHEMA_POLICY` procedure applies a policy to all of the tables in a schema and enables the policy for these tables.

That is, it applies to those tables that do not already have the policy applied. Then, whenever a new table is created in the schema, the policy is automatically applied to that table, using the schema's default options. No changes are made to existing tables in the schema that already have the policy applied.

Syntax

```
SA_POLICY_ADMIN.APPLY_SCHEMA_POLICY (
  policy_name      IN VARCHAR2,
  schema_name      IN VARCHAR2,
  default_options  IN VARCHAR2 DEFAULT NULL);
```

Parameters

Table E-22 SA_POLICY_ADMIN.APPLY_SCHEMA_POLICY Parameters

| Parameter | Description |
|------------------------------|--|
| <code>policy_name</code> | Specifies the policy. To find existing policies, query the <code>POLICY_NAME</code> column of the <code>ALL_SA_POLICIES</code> data dictionary view. |
| <code>schema_name</code> | The schema that contains the table to protect |
| <code>default_options</code> | The default options to be used for tables in the schema. Separate each option with a comma. If the <code>default_options</code> parameter is <code>NULL</code> , then the policy's default options will be used to apply the policy to the tables in the schema. See Table 8-2 for a listing of the default enforcement options. |

Example

The following example applies the `READ_CONTROL` and `WRITE_CONTROL` options to the `HR` schema.

```
BEGIN
  SA_POLICY_ADMIN.APPLY_SCHEMA_POLICY(
    policy_name      => 'hr_ols_pol',
    schema_name      => 'HR',
    default_options  => 'read_control, write_control');
END;
/
```

SA_POLICY_ADMIN.APPLY_TABLE_POLICY

The `SA_POLICY_ADMIN.APPLY_TABLE_POLICY` procedure adds the specified policy to a table.

A policy label column is added to the table if it does not exist, and is set to `NULL`. When a policy is applied, it is automatically enabled. To change the table options, labeling function, or predicate, you must first remove the policy, and then reapply it.

Syntax

```
SA_POLICY_ADMIN.APPLY_TABLE_POLICY (
  policy_name      IN VARCHAR2,
  schema_name     IN VARCHAR2,
  table_name       IN VARCHAR2,
  table_options    IN VARCHAR2 DEFAULT NULL,
  label_function   IN VARCHAR2 DEFAULT NULL,
  predicate        IN VARCHAR2 DEFAULT NULL);
```

Parameters

Table E-23 SA_POLICY_ADMIN.APPLY_TABLE_POLICY Parameters

| Parameter | Description |
|----------------|---|
| policy_name | Specifies the policy. To find existing policies, query the POLICY_NAME column of the ALL_SA_POLICIES data dictionary view. |
| schema_name | The schema that contains the table that the policy protects |
| table_name | The table to be protected by the policy |
| table_options | A comma-delimited list of policy enforcement options to be used for the table. If NULL, then the policy's default options are used. See Table 8-2 for a listing of the default enforcement options. |
| label_function | A string calling a function to return a label value to use as the default. For example, my_label(:new.dept, :new.status) computes the label based on the new values of the DEPT and STATUS columns in the row. |
| predicate | An additional predicate to combine (using AND or OR) with the label-based predicate for READ_CONTROL |

Example

The following statement applies the hr_ols_pol policy to the EMPLOYEES table in the HR schema.

```
BEGIN
  SA_POLICY_ADMIN.APPLY_TABLE_POLICY(
    policy_name => 'hr_ols_pol',
    schema_name => 'HR',
    table_name  => 'EMPLOYEES',
    table_options => NULL,
    label_function => 'hs(:new.dept, :new.status)',
    predicate   => 'no_control');
END;
/
```

SA_POLICY_ADMIN.DISABLE_SCHEMA_POLICY

The SA_POLICY_ADMIN.DISABLE_SCHEMA_POLICY procedure disables the enforcement of the policy for all tables in a schema.

However, it does not change the enforcement options, labeling function, or predicate values.

This procedure removes the row level security predicate and DML triggers from all the tables in the schema.

Syntax

```
SA_POLICY_ADMIN.DISABLE_SCHEMA_POLICY (
  policy_name   IN VARCHAR2,
  schema_name   IN VARCHAR2);
```

Parameters

Table E-24 SA_POLICY_ADMIN.DISABLE_SCHEMA_POLICY Parameters

| Parameter | Description |
|-------------|---|
| policy_name | Specifies the policy. To find existing policies, query the POLICY_NAME column of the ALL_SA_POLICIES data dictionary view. |
| schema_name | The schema that contains the table for this policy. To find this schema, query the POLICY_NAME and SCHEMA_NAME columns of the ALL_SA_TABLE_POLICIES view. |

Example

The following example disables the hr_ols_pol policy for the HR schema.

```
BEGIN
  SA_POLICY_ADMIN.DISABLE_SCHEMA_POLICY(
    policy_name   => 'hr_ols_pol',
    schema_name   => 'HR');
END;
/
```

SA_POLICY_ADMIN.DISABLE_TABLE_POLICY

The SA_POLICY_ADMIN.DISABLE_TABLE_POLICY procedure disables the enforcement of the policy for a table without changing the enforcement options, labeling function, or predicate values.

This procedure removes the row level security predicate and DML triggers from the table.

Syntax

```
SA_POLICY_ADMIN.DISABLE_TABLE_POLICY (
  policy_name   IN VARCHAR2,
  schema_name   IN VARCHAR2,
  table_name    IN VARCHAR2);
```

Parameters

Table E-25 SA_POLICY_ADMIN.DISABLE_TABLE_POLICY Parameters

| Parameter | Description |
|-------------|---|
| policy_name | Specifies the policy. To find existing policies, query the POLICY_NAME column of the ALL_SA_POLICIES data dictionary view. |
| schema_name | The schema that contains the table. To find this schema, query the POLICY_NAME and SCHEMA_NAME columns of the ALL_SA_TABLE_POLICIES view. |
| table_name | The table in the schema specified by schema_name. To find this table, query the POLICY_NAME, SCHEMA_NAME, and TABLE_NAME columns of the ALL_SA_TABLE_POLICIES view. |

Example

The following statement disables the `hr_ols_pos` policy on the `EMPLOYEES` table in the `HR` schema:

```
BEGIN
  SA_POLICY_ADMIN.DISABLE_TABLE_POLICY(
    policy_name => 'hr_ols_pol',
    schema_name => 'HR',
    table_name  => 'EMPLOYEES');
END;
/
```

SA_POLICY_ADMIN.ENABLE_SCHEMA_POLICY

The `SA_POLICY_ADMIN.ENABLE_SCHEMA_POLICY` procedure reenables the current enforcement options, labeling function, and predicate for the tables in the specified schema.

It accomplishes this by re-applying the row level security predicate and DML triggers. The result is similar to enabling a policy for a table, but it covers all the tables in the schema.

Syntax

```
SA_POLICY_ADMIN.ENABLE_SCHEMA_POLICY (
  policy_name  IN VARCHAR2,
  schema_name  IN VARCHAR2);
```

Parameters

Table E-26 SA_POLICY_ADMIN.ENABLE_SCHEMA_POLICY Parameters

| Parameter | Description |
|-------------|---|
| policy_name | Specifies the policy. To find existing policies and their status, query the POLICY_NAME and STATUS columns of the ALL_SA_POLICIES data dictionary view. |

Table E-26 (Cont.) SA_POLICY_ADMIN.ENABLE_SCHEMA_POLICY Parameters

| Parameter | Description |
|-------------|---|
| schema_name | The schema that contains the table. To find this schema, query the POLICY_NAME and SCHEMA_NAME columns of the ALL_SA_TABLE_POLICIES view. |

Example

The following example enables the hr_ols_pol policy for the HR schema.

```
BEGIN
  SA_POLICY_ADMIN.ENABLE_SCHEMA_POLICY(
    policy_name => 'hr_ols_pol',
    schema_name => 'HR');
END;
/
```

SA_POLICY_ADMIN.ENABLE_TABLE_POLICY

The SA_POLICY_ADMIN.ENABLE_TABLE_POLICY procedure reenables the current enforcement options, labeling function, and predicate for the specified table.

It accomplishes this by reapplying the row level security predicate and DML triggers.

Syntax

```
SA_POLICY_ADMIN.ENABLE_TABLE_POLICY (
  policy_name    IN VARCHAR2,
  schema_name    IN VARCHAR2,
  table_name     IN VARCHAR2);
```

Parameters**Table E-27 SA_POLICY_ADMIN.ENABLE_TABLE_POLICY Parameters**

| Parameter | Description |
|-------------|---|
| policy_name | Specifies the policy. POLICY_NAME and STATUS columns of the ALL_SA_POLICIES data dictionary view. |
| schema_name | The schema that contains the table. To find this schema, query the POLICY_NAME and SCHEMA_NAME columns of the ALL_SA_TABLE_POLICIES view. |
| table_name | The table in the schema specified by schema_name. To find this table, query the POLICY_NAME, SCHEMA_NAME, and TABLE_NAME columns of the ALL_SA_TABLE_POLICIES view. |

Example

The following statement reenables the hr_ols_pol policy on the EMPLOYEES table in the HR schema:

```
BEGIN
  SA_POLICY_ADMIN.ENABLE_TABLE_POLICY(
    policy_name => 'hr_ols_pol',
```

```

    schema_name => 'HR',
    table_name  => 'EMPLOYEES');
END;
/

```

SA_POLICY_ADMIN.POLICY_SUBSCRIBE

In an Oracle Internet Directory-enabled Oracle Label Security configuration, the `SA_POLICY_ADMIN.POLICY_SUBSCRIBE` procedure subscribes to the policy for usage in `SA_POLICY_ADMIN.APPLY_TABLE_POLICY` and `SA_POLICY_ADMIN.APPLY_SCHEMA_POLICY`.

You must call this procedure for a policy before that policy can be applied to a table or schema. Subscribing is needed only once, not for each use of the policy in a table or schema.

You cannot drop any subscribed policy unless it has been removed from any table or schema to which it was applied, and then unsubscribed.

Syntax

```

SA_POLICY.POLICY_SUBSCRIBE(
    policy_name  IN VARCHAR2);

```

Parameter

Table E-28 SA_POLICY_ADMIN.POLICY_SUBSCRIBE Parameter

| Parameter | Description |
|--------------------------|--|
| <code>policy_name</code> | Specifies the policy. To find existing policies, query the <code>POLICY_NAME</code> column of the <code>ALL_SA_POLICIES</code> data dictionary view. |

Note:

This procedure must be used before policy usage only in the case of Oracle Internet Directory-enabled Oracle Label Security configuration. In the standalone Oracle Label Security case, the policy can be used in `APPLY_TABLE_POLICY` and `APPLY_SCHEMA_POLICY` directly without the need to subscribe.

Example

The following statement subscribes the database to the `hr_ols_pol` policy so that it can be used by applying on tables and schema.

```

BEGIN
    SA_POLICY_ADMIN.POLICY_SUBSCRIBE(
        policy_name => 'hr_ols_pol');
END;
/

```

SA_POLICY_ADMIN.POLICY_UNSUBSCRIBE

In an Oracle Internet Directory enabled Oracle Label Security configuration, the `SA_POLICY_ADMIN.POLICY_UNSUBSCRIBE` procedure unsubscribes to the policy.

You can use this procedure only if the policy is not in use; that is, it has not been applied to any table or schema. (If it has been applied to tables or schemas, then it must be removed from all of them before it can be unsubscribed.) A policy can be dropped in Oracle Internet Directory only if it is not subscribed in any of the databases that have registered with that Oracle Internet Directory. To unsubscribe a policy, use the `olsadmintool dropprofile` command.

You cannot drop any subscribed policy unless it has been removed from any table or schema to which it was applied, and then unsubscribed.

Syntax

```
SA_POLICY_ADMIN.POLICY_UNSUBSCRIBE(  
  policy_name IN VARCHAR2);
```

Parameter

Table E-29 SA_POLICY_ADMIN.POLICY_UNSUBSCRIBE Parameters

| Parameter | Description |
|--------------------------|--|
| <code>policy_name</code> | Specifies the policy. To find existing policies, query the <code>POLICY_NAME</code> column of the <code>ALL_SA_POLICIES</code> data dictionary view. |

Example

The following statement unsubscribes the database to the `hr_ols_pol` policy.

```
BEGIN  
  SA_POLICY_ADMIN.POLICY_UNSUBSCRIBE(  
    policy_name => 'hr_ols_pol');  
END;  
/
```

SA_POLICY_ADMIN.REMOVE_SCHEMA_POLICY

The `SA_POLICY_ADMIN.REMOVE_SCHEMA_POLICY` procedure removes the specified policy from a schema.

The policy will be removed from all the tables in the schema and, optionally, the label column for the policy will be dropped from all the tables.

Syntax

```
SA_POLICY_ADMIN.REMOVE_SCHEMA_POLICY (  
  policy_name      IN VARCHAR2,  
  schema_name      IN VARCHAR2,  
  drop_column      IN BOOLEAN DEFAULT FALSE);
```

Parameters

Table E-30 SA_POLICY_ADMIN.REMOVE_SCHEMA_POLICY Parameters

| Parameter | Description |
|-------------|--|
| policy_name | Specifies the policy. To find existing policies, query the POLICY_NAME column of the ALL_SA_POLICIES data dictionary view. |
| schema_name | The schema that contains the table associated with this policy. To find this schema, query the SCHEMA_NAME of the ALL_SA_SCHEMA_POLICIES view. |
| drop_column | If TRUE, then the policy's column will be dropped from the tables, otherwise, the column will remain. |

Example

The following example drops the `human_resource` policy's column from the `HR` schema.

```
BEGIN
  SA_POLICY_ADMIN.REMOVE_SCHEMA_POLICY(
    policy_name    => 'hr_ols_pol',
    schema_name    => 'HR',
    drop_column    => TRUE);
END;
/
```

SA_POLICY_ADMIN.REMOVE_TABLE_POLICY

The `SA_POLICY_ADMIN.REMOVE_TABLE_POLICY` procedure removes the specified policy from a table.

The policy predicate and any DML triggers will be removed from the table, and the policy label column can optionally be dropped. Policies can be removed from tables belonging to a schema that is protected by the policy.

Syntax

```
SA_POLICY_ADMIN.REMOVE_TABLE_POLICY (
  policy_name    IN VARCHAR2,
  schema_name    IN VARCHAR2,
  table_name     IN VARCHAR2,
  drop_column    IN BOOLEAN DEFAULT FALSE);
```

Parameters

Table E-31 SA_POLICY_ADMIN.REMOVE_TABLE_POLICY Parameters

| Parameter | Description |
|-------------|--|
| policy_name | Specifies the policy. To find existing policies, query the POLICY_NAME column of the ALL_SA_POLICIES data dictionary view. |

Table E-31 (Cont.) SA_POLICY_ADMIN.REMOVE_TABLE_POLICY Parameters

| Parameter | Description |
|-------------|--|
| schema_name | The schema that contains the table associated with this policy. To find this schema, query the SCHEMA_NAME of the ALL_SA_SCHEMA_POLICIES view. |
| table_name | The table in the schema specified by schema_name. To find this table query the POLICY_NAME, SCHEMA_NAME, and TABLE_NAME columns of the ALL_SA_TABLE_POLICIES view. |
| drop_column | Whether the column is to be dropped: if TRUE, then the policy's column will be dropped from the table, otherwise, it will remain |

Example

The following statement removes the hr_ols_pol policy from the EMPLOYEES table in the HR schema:

```
BEGIN
  SA_POLICY_ADMIN.REMOVE_TABLE_POLICY(
    policy_name => 'hr_ols_pol',
    schema_name => 'HR',
    table_name  => 'EMPLOYEES',
    drop_column => TRUE);
END;
/
```

SA_SESSION Session Management PL/SQL Package

The SA_SESSION PL/SQL package manages session behavior for user authorizations.

- [About the SA_SESSION PL/SQL Package](#)
The SA_SESSION PL/SQL package manages user name, levels, labels, and read and write permissions for a user session.
- [SA_SESSION.COMP_READ](#)
The SA_SESSION.COMP_READ function returns a comma-delimited list of compartments that the user is authorized to read.
- [SA_SESSION.COMP_WRITE](#)
The SA_SESSION.COMP_WRITE function returns a comma-delimited list of compartments to which the user is authorized to write.
- [SA_SESSION.GROUP_READ](#)
The SA_SESSION.GROUP_READ function returns a comma-delimited list of groups that the user is authorized to read.
- [SA_SESSION.GROUP_WRITE](#)
The SA_SESSION.GROUP_WRITE function returns a comma-delimited list of groups that the user is authorized to write.
- [SA_SESSION.LABEL](#)
The SA_SESSION.LABEL function returns the label that is associated with the specified policy for the current session.

- [SA_SESSION.MAX_LEVEL](#)
The `SA_SESSION.MAX_LEVEL` function returns the maximum Oracle Label Security level authorized for the session.
- [SA_SESSION.MAX_READ_LABEL](#)
The `SA_SESSION.MAX_READ_LABEL` function returns the label string that was used to initialize the user's maximum authorized read label.
- [SA_SESSION.MAX_WRITE_LABEL](#)
The `SA_SESSION.MAX_WRITE_LABEL` function returns the label string that was used to initialize the user's maximum authorized write label.
- [SA_SESSION.MIN_LEVEL](#)
The `SA_SESSION.MIN_LEVEL` function returns the minimum Oracle Label Security level authorized for the session.
- [SA_SESSION.MIN_WRITE_LABEL](#)
The `SA_SESSION.MIN_WRITE_LABEL` function retrieves the label string that was used to initialize the user's minimum authorized write label.
- [SA_SESSION.PRIVS](#)
The `SA_SESSION.PRIVS` function returns the set of current session privileges, in a comma-delimited list.
- [SA_SESSION.RESTORE_DEFAULT_LABELS](#)
The `SA_SESSION.RESTORE_DEFAULT_LABELS` procedure restores the session label and row label to those stored in the data dictionary.
- [SA_SESSION.ROW_LABEL](#)
The `SA_SESSION.ROW_LABEL` function returns the name of the row label that is associated with the policy for the current session.
- [SA_SESSION.SET_LABEL](#)
The `SA_SESSION.SET_LABEL` procedure sets the label of the current database session.
- [SA_SESSION.SA_USER_NAME](#)
The `SA_SESSION.SA_USER_NAME` function returns the name of the current Oracle Label Security user, as set by the `SA_SESSION.SET_ACCESS_PROFILE` procedure (or as established at login).
- [SA_SESSION.SAVE_DEFAULT_LABELS](#)
The `SA_SESSION.SAVE_DEFAULT_LABELS` procedure stores the current session label and row label as your initial session label and default row label.
- [SA_SESSION.SET_ACCESS_PROFILE](#)
The `SA_SESSION.SET_ACCESS_PROFILE` procedure sets the Oracle Label Security authorizations and privileges of the database session to those of the specified user.
- [SA_SESSION.SET_ROW_LABEL](#)
The `SA_SESSION.SET_ROW_LABEL` procedure sets the default row label value for the current database session.

About the SA_SESSION PL/SQL Package

The `SA_SESSION` PL/SQL package manages user name, levels, labels, and read and write permissions for a user session.

Users can change labels during a session within the authorizations set by the administrator.

You do not need special privileges to use this package.

**See Also:**

[SA_UTL PL/SQL Utility Functions and Procedures](#) for additional functions that return numeric label tags and `BOOLEAN` values

SA_SESSION.COMP_READ

The `SA_SESSION.COMP_READ` function returns a comma-delimited list of compartments that the user is authorized to read.

Syntax

```
SA_SESSION.COMP_READ (  
    policy_name IN VARCHAR2)  
RETURN VARCHAR2;
```

Parameter

Table E-32 SA_SESSION.COMP_READ Parameter

| Parameter | Description |
|--------------------------|--|
| <code>policy_name</code> | Specifies the policy. To find existing policies, query the <code>POLICY_NAME</code> column of the <code>ALL_SA_POLICIES</code> data dictionary view. |

Example

The following example returns the compartments that the user can read for the `hr_ols_pol` policy.

```
SELECT SA_SESSION.COMP_READ ('hr_ols_pol') FROM DUAL;
```

SA_SESSION.COMP_WRITE

The `SA_SESSION.COMP_WRITE` function returns a comma-delimited list of compartments to which the user is authorized to write.

This function is a subset of `SA_SESSION.COMP_READ`.

Syntax

```
SA_SESSION.COMP_WRITE (  
    policy_name IN VARCHAR2)  
RETURN VARCHAR2;
```

Parameter

Table E-33 SA_SESSION.COMP_WRITE Parameter

| Parameter | Description |
|-------------|--|
| policy_name | Specifies the policy. To find existing policies, query the POLICY_NAME column of the ALL_SA_POLICIES data dictionary view. |

Example

The following example returns the compartments that the user can modify for the hr_ols_pol policy.

```
SELECT SA_SESSION.COMP_WRITE ('hr_ols_pol') FROM DUAL;
```

SA_SESSION.GROUP_READ

The SA_SESSION.GROUP_READ function returns a comma-delimited list of groups that the user is authorized to read.

Syntax

```
SA_SESSION.GROUP_READ (
  policy_name IN VARCHAR2)
RETURN VARCHAR2;
```

Parameter

Table E-34 SA_SESSION.GROUP_READ Parameter

| Parameter | Description |
|-------------|--|
| policy_name | Specifies the policy. To find existing policies, query the POLICY_NAME column of the ALL_SA_POLICIES data dictionary view. |

Example

The following example returns the list of groups that a user can read for the hr_ols_pol policy.

```
SELECT SA_SESSION.GROUP_READ ('hr_ols_pol') FROM DUAL;
```

SA_SESSION.GROUP_WRITE

The SA_SESSION.GROUP_WRITE function returns a comma-delimited list of groups that the user is authorized to write.

This function is a subset of SA_SESSION.GROUP_READ.

Syntax

```
SA_SESSION.GROUP_WRITE (
  policy_name IN VARCHAR2)
RETURN VARCHAR2;
```

Parameter**Table E-35 SA_SESSION.GROUP_WRITE Parameter**

| Parameter | Description |
|-------------|--|
| policy_name | Specifies the policy. To find existing policies, query the POLICY_NAME column of the ALL_SA_POLICIES data dictionary view. |

Example

The following example returns the groups the user is authorized to modify for the hr_ols_pol policy.

```
SELECT SA_SESSION.GROUP_WRITE ('hr_ols_pol') FROM DUAL;
```

SA_SESSION.LABEL

The SA_SESSION.LABEL function returns the label that is associated with the specified policy for the current session.

Syntax

```
SA_SESSION.LABEL (
  policy_name IN VARCHAR2)
RETURN VARCHAR2;
```

Parameter**Table E-36 SA_SESSION.LABEL Parameter**

| Parameter | Description |
|-------------|--|
| policy_name | Specifies the policy. To find existing policies, query the POLICY_NAME column of the ALL_SA_POLICIES data dictionary view. |

Example

The following example returns the label that is associated with the hr_ols_pol policy.

```
SELECT SA_SESSION.LABEL ('hr_ols_pol') FROM DUAL;
```

SA_SESSION.MAX_LEVEL

The `SA_SESSION.MAX_LEVEL` function returns the maximum Oracle Label Security level authorized for the session.

Syntax

```
SA_SESSION.MAX_LEVEL (
    policy_name IN VARCHAR2)
RETURN VARCHAR2;
```

Parameter

Table E-37 SA_SESSION.MAX_LEVEL Parameter

| Parameter | Description |
|-------------|--|
| policy_name | Specifies the policy. To find existing policies, query the <code>POLICY_NAME</code> column of the <code>ALL_SA_POLICIES</code> data dictionary view. |

Example

The following example returns the maximum Oracle Label Security level that is authorized for the `hr_ols_pol` policy.

```
SELECT SA_SESSION.MAX_LEVEL ('hr_ols_pol') FROM DUAL;
```

SA_SESSION.MAX_READ_LABEL

The `SA_SESSION.MAX_READ_LABEL` function returns the label string that was used to initialize the user's maximum authorized read label.

The return string is composed of the user's maximum level, compartments authorized for read access, and groups authorized for read access.

Syntax

```
SA_SESSION.MAX_READ_LABEL (
    policy_name IN VARCHAR2)
RETURN VARCHAR2;
```

Parameter

Table E-38 SA_SESSION.MAX_READ_LABEL Parameter

| Parameter | Description |
|-------------|--|
| policy_name | Specifies the policy. To find existing policies, query the <code>POLICY_NAME</code> column of the <code>ALL_SA_POLICIES</code> data dictionary view. |

Example

The following example returns the maximum read label privileges for the `hr_ols_pol` policy.

```
SELECT SA_SESSION.MAX_READ_LABEL ('hr_ols_pol') FROM DUAL;
```

SA_SESSION.MAX_WRITE_LABEL

The `SA_SESSION.MAX_WRITE_LABEL` function returns the label string that was used to initialize the user's maximum authorized write label.

This return string is composed of the user's maximum level, compartments authorized for write access, and groups authorized for write access.

Syntax

```
SA_SESSION.MAX_WRITE_LABEL (
  policy_name IN VARCHAR2)
RETURN VARCHAR2;
```

Parameter

Table E-39 SA_SESSION.MAX_WRITE_LABEL Parameter

| Parameter | Description |
|-------------|--|
| policy_name | Specifies the policy. To find existing policies, query the <code>POLICY_NAME</code> column of the <code>ALL_SA_POLICIES</code> data dictionary view. |

Example

The following example returns the maximum write label privileges for the `hr_ols_pol` policy.

```
SELECT SA_SESSION.MAX_WRITE_LABEL ('hr_ols_pol') FROM DUAL;
```

SA_SESSION.MIN_LEVEL

The `SA_SESSION.MIN_LEVEL` function returns the minimum Oracle Label Security level authorized for the session.

Syntax

```
SA_SESSION.MIN_LEVEL (
  policy_name IN VARCHAR2)
RETURN VARCHAR2;
```

Parameter

Table E-40 SA_SESSION.MIN_LEVEL Parameter

| Parameter | Description |
|-------------|--|
| policy_name | Specifies the policy. To find existing policies, query the <code>POLICY_NAME</code> column of the <code>ALL_SA_POLICIES</code> data dictionary view. |

Example

The following example returns the current minimum level for the `hr_ols_pol` policy.

```
SELECT SA_SESSION.MIN_LEVEL ('hr_ols_pol') FROM DUAL;
```

SA_SESSION.MIN_WRITE_LABEL

The `SA_SESSION.MIN_WRITE_LABEL` function retrieves the label string that was used to initialize the user's minimum authorized write label.

The return string contains only the level, with no compartments or groups.

Syntax

```
SA_SESSION.MIN_WRITE_LABEL (
  policy_name IN VARCHAR2)
RETURN VARCHAR2;
```

Parameter

Table E-41 SA_SESSION.MIN_WRITE_LABEL Parameter

| Parameter | Description |
|-------------|--|
| policy_name | Specifies the policy. To find existing policies, query the <code>POLICY_NAME</code> column of the <code>ALL_SA_POLICIES</code> data dictionary view. |

Example

The following example returns the maximum write label privileges for the `hr_ols_pol` policy.

```
SELECT SA_SESSION.MIN_WRITE_LABEL ('hr_ols_pol') FROM DUAL;
```

SA_SESSION.PRIVS

The `SA_SESSION.PRIVS` function returns the set of current session privileges, in a comma-delimited list.

Syntax

```
SA_SESSION.PRIVS (
  policy_name IN VARCHAR2)
RETURN VARCHAR2;
```

Parameter

Table E-42 SA_SESSION.Privs Parameter

| Parameter | Description |
|-------------|--|
| policy_name | Specifies the policy. To find existing policies, query the <code>POLICY_NAME</code> column of the <code>ALL_SA_POLICIES</code> data dictionary view. |

Example

The following example returns the current session privileges for the `hr_ols_pol` policy.

```
SELECT SA_SESSION.PRIVS ('hr_ols_pol') FROM DUAL;
```

SA_SESSION.RESTORE_DEFAULT_LABELS

The `SA_SESSION.RESTORE_DEFAULT_LABELS` procedure restores the session label and row label to those stored in the data dictionary.

This command is useful to reset values after a `SA_SESSION.SET_LABEL` command has been processed.

Syntax

```
SA_SESSION.RESTORE_DEFAULT_LABELS (  
  policy_name in VARCHAR2);
```

Parameter

Table E-43 SA_SESSION.RESTORE_DEFAULT_LABEL Parameter

| Parameter | Description |
|--------------------------|--|
| <code>policy_name</code> | Specifies the policy. To find existing policies, query the <code>POLICY_NAME</code> column of the <code>ALL_SA_POLICIES</code> data dictionary view. |

Example

The following example restores the default labels for the `hr_ols_pol` policy.

```
BEGIN  
  SA_SESSION.RESTORE_DEFAULT_LABELS (  
    policy_name      => 'hr_ols_pol');  
END;  
/
```

SA_SESSION.ROW_LABEL

The `SA_SESSION.ROW_LABEL` function returns the name of the row label that is associated with the policy for the current session.

Syntax

```
SA_SESSION.ROW_LABEL (  
  policy_name IN VARCHAR2)  
RETURN VARCHAR2;
```

Parameter

Table E-44 SA_SESSION.ROW_LABEL Parameters

| Parameter | Description |
|--------------------------|--|
| <code>policy_name</code> | Specifies the policy. To find existing policies, query the <code>POLICY_NAME</code> column of the <code>ALL_SA_POLICIES</code> data dictionary view. |

Example

The following example returns the row label that is associated with the `hr_ols_pol` policy.

```
SELECT SA_SESSION.ROW_LABEL ('hr_ols_pol') FROM DUAL;
```

SA_SESSION.SET_LABEL

The `SA_SESSION.SET_LABEL` procedure sets the label of the current database session.

You can set the session label to:

- Any level equal to or less than the maximum, and equal to or greater than the minimum level
- Include any compartments in the authorized compartment list
- Include any groups in the authorized group list. (Subgroups of authorized groups are implicitly included in the authorized list.)

Note that if you change the session label, this change may affect the value of the session's row label. The session's row label contains the subset of compartments and groups for which the user has write access. This may or may not be equivalent to the session label. For example, if you use the `SA_SESSION.SET_LABEL` procedure to set your current session label to `C:A,B:US` and you have write access only on the `A` compartment, then your row label would be set to `C:A`.

Syntax

```
SA_SESSION.SET_LABEL (
  policy_name IN VARCHAR2,
  label       IN VARCHAR2);
```

Parameters

Table E-45 SA_SESSION.SET_LABEL Parameters

| Parameter | Description |
|--------------------------|--|
| <code>policy_name</code> | Specifies the policy. To find existing policies, query the <code>POLICY_NAME</code> column of the <code>ALL_SA_POLICIES</code> data dictionary view. |
| <code>label</code> | The value to set as the label |

Example

The following example sets the label for the `hr_ols_pol` policy.

```
BEGIN
  SA_SESSION.SET_LABEL (
    policy_name => 'hr_ols_pol',
    label       => 'C:A,B:US');
END;
/
```

Related Topics

- [SA_USER_ADMIN.SET_DEFAULT_LABEL](#)
The `SA_USER_ADMIN.SET_DEFAULT_LABEL` procedure sets the user's initial session label to the one specified.

SA_SESSION.SA_USER_NAME

The `SA_SESSION.SA_USER_NAME` function returns the name of the current Oracle Label Security user, as set by the `SA_SESSION.SET_ACCESS_PROFILE` procedure (or as established at login).

This is how you can determine the identity of the current user in relation to Oracle Label Security, rather than in relation to your Oracle login name.

Syntax

```
SA_SESSION.SA_USER_NAME (
    policy_name IN VARCHAR2)
RETURN VARCHAR2;
```

Parameter

Table E-46 SA_SESSION.SA_USER_NAME Parameters

| Parameter | Description |
|--------------------------|--|
| <code>policy_name</code> | Specifies the policy. To find existing policies, query the <code>POLICY_NAME</code> column of the <code>ALL_SA_POLICIES</code> data dictionary view. |

Example

The following example finds the name of the Oracle Label Security user for the `hr_ols_pol` policy.

```
SELECT SA_SESSION.SA_USER_NAME ('hr_ols_pol') FROM DUAL;
```

SA_SESSION.SAVE_DEFAULT_LABELS

The `SA_SESSION.SAVE_DEFAULT_LABELS` procedure stores the current session label and row label as your initial session label and default row label.

This procedure permits you to change your defaults to reflect your current session label and row label. The saved labels will be used as the initial default settings for future sessions.

When you log in to a database, your default session label and row label are used to initialize the session label and row label. When the administrator originally authorized your Oracle Label Security labels, he or she also defined your default level, default compartments, and default groups. If you change your session label and row label, and want to save these values as the default labels, you can use the `SA_SESSION.SAVE_DEFAULT_LABELS` procedure.

This procedure is useful if you have multiple sessions and want to be sure that all additional sessions have the same labels. You can save the current labels as the default, and all future sessions will have these as the initial labels.

Consider a situation in which you connect to the database through Oracle Forms and want to run a report. By saving the current session labels as the default before you call Oracle Reports, you ensure that Oracle Reports will initialize at the same labels as are being used by Oracle Forms.

Syntax

```
SA_SESSION.SAVE_DEFAULT_LABELS (
  policy_name IN VARCHAR2);
```

Parameter

Table E-47 SA_SESSION.SAVE_DEFAULT_LABELS Parameter

| Parameter | Description |
|-------------|--|
| policy_name | Specifies the policy. To find existing policies, query the POLICY_NAME column of the ALL_SA_POLICIES data dictionary view. |

Example

The following example saves the label defaults for the hr_ols_pol policy.

```
BEGIN
  SA_SESSION.SAVE_DEFAULT_LABELS (
    policy_name      => 'hr_ols_pol');
END;
/
```

Note:

The SA_SESSION.SAVE_DEFAULT_LABELS procedure overrides the settings established by the administrator.

SA_SESSION.SET_ACCESS_PROFILE

The SA_SESSION.SET_ACCESS_PROFILE procedure sets the Oracle Label Security authorizations and privileges of the database session to those of the specified user.

Note that the originating user retains the PROFILE_ACCESS privilege.

The user who executes the SA_SESSION.SET_ACCESS_PROFILE procedure must have the PROFILE_ACCESS privilege. The logged-in database user (the Oracle user ID) does not change. That user assumes only the authorizations and privileges of the specified user. By contrast, the Oracle Label Security user name *is* changed.

This administrative procedure is useful for various tasks:

- With SA_SESSION.SET_ACCESS_PROFILE, you can see the result of the authorization and privilege settings for a particular user.
- Applications need to have proxy accounts connect as (and assume the identity of) application users, for purposes of accessing labeled data. With the

SA_SESSION.SET_ACCESS_PROFILE privilege, the proxy account can act on behalf of the application users.

Syntax

```
SA_SESSION.SET_ACCESS_PROFILE (
  policy_name IN VARCHAR2
  user_name   IN VARCHAR2);
```

Parameters

Table E-48 SA_SESSION.SET_ACCESS_PROFILE Parameters

| Parameter | Description |
|-------------|--|
| policy_name | Specifies the policy. To find existing policies, query the POLICY_NAME column of the ALL_SA_POLICIES data dictionary view. |
| user_name | Name of the user whose authorizations and privileges should be assumed (typically, the user associated with this policy). To find this user, query the USER_NAME and POLICY_NAME columns of the DBA_SA_USERS view. |

Example

The following example enables user `psmith` to have Oracle Label Security authorizations and privileges for the database session.

```
BEGIN
  SA_SESSION.SET_ACCESS_PROFILE (
    policy_name => 'hr_ols_pol',
    user_name   => 'jjones');
END;
/
```

SA_SESSION.SET_ROW_LABEL

The `SA_SESSION.SET_ROW_LABEL` procedure sets the default row label value for the current database session.

The compartments and groups in the label must be a subset of the compartments and groups in the session label to which the user has write access. When the `LABEL_DEFAULT` option is set, this row label value is used on insert if the user does not explicitly specify the label.

If the `SA_SESSION.SET_ROW_LABEL` procedure is not used to set the default row label value, then this value is automatically derived from the session label. It contains the level of the session label and the subset of the compartments and groups in the session label for which the user has write authorization.

The row label is automatically reset if the session label changes. For example, if you change your session level from `HIGHLY_SENSITIVE` to `SENSITIVE`, then the level component of the row label automatically changes to `SENSITIVE`.

The user can set the row label independently, but only to include:

- A level that is less than or equal to the level of the session label, and greater than or equal to the user's minimum level
- A subset of the compartments and groups from the session label, for which the user is authorized to have write access

If the user tries to set the row label to an invalid value, then the operation is not permitted and the row label value is unchanged.

Syntax

```
SA_SESSION.SET_ROW_LABEL (
  policy_name  IN VARCHAR2,
  row_label    IN VARCHAR2);
```

Parameters

Table E-49 SA_SESSION.SET_ROW_LABEL Parameters

| Parameter | Description |
|-------------|--|
| policy_name | Specifies the policy. To find existing policies, query the POLICY_NAME column of the ALL_SA_POLICIES data dictionary view. |
| label | The value to set as the default row label |

Example

The following example sets the row label for the hr_ols_pol policy.

```
BEGIN
  SA_SESSION.SET_ROW_LABEL (
    policy_name => 'hr_ols_pol',
    label       => 'HR');
END;
/
```

Related Topics

- [SA_USER_ADMIN.SET_ROW_LABEL](#)
The SA_USER_ADMIN.SET_ROW_LABEL procedure sets a user's initial row label to the one specified.

SA_SYSDBA Policy Management PL/SQL Package

The SA_SYSDBA PL/SQL package manages Oracle Label Security policies.

- [About the SA_SYSDBA PL/SQL Package](#)
The SA_SYSDBA PL/SQL package creates, modifies, enables or disables, and drops Oracle Label Security policies.
- [SA_SYSDBA.ALTER_POLICY](#)
The SA_SYSDBA.ALTER_POLICY procedure sets and modifies column names that are associated with the policy.
- [SA_SYSDBA.CREATE_POLICY](#)
The SA_SYSDBA.CREATE_POLICY procedure creates a new Oracle Label Security policy, defines a policy-specific column name, and specifies default policy options.

- **SA_SYSDBA.DISABLE_POLICY**
The `SA_SYSDBA.DISABLE_POLICY` procedure turns off enforcement of a policy, without removing it from the database.
- **SA_SYSDBA.DROP_POLICY**
The `SA_SYSDBA.DROP_POLICY` procedure deletes the policy and its associated user labels and data labels from the database.
- **SA_SYSDBA.ENABLE_POLICY**
The `SA_SYSDBA.ENABLE_POLICY` procedure enforces access control on the tables and schemas protected by the policy.

About the SA_SYSDBA PL/SQL Package

The `SA_SYSDBA` PL/SQL package creates, modifies, enables or disables, and drops Oracle Label Security policies.

To use this package, you must be granted the `LBAC_DBA` role and the `EXECUTE` privilege on the `SA_SYSDBA` package. The `SA_SYSDBA` package is an invoker's rights package, so you must provide the following `INHERIT PRIVILEGES` grant to the user `SYS` before you can use this package:

```
GRANT INHERIT PRIVILEGES ON USER SYS TO LBACSYS;
```

You only need to grant this privilege on user `SYS`. You do not need to grant it on other users.

SA_SYSDBA.ALTER_POLICY

The `SA_SYSDBA.ALTER_POLICY` procedure sets and modifies column names that are associated with the policy.

`SA_SYSDBA.ALTER_POLICY` can only be used to change column name for policies that are not applied on any user tables or schemas. Otherwise, this error appears:

```
12474, 00000, "cannot change column name for a policy in use"
```

Syntax

```
SA_SYSDBA.ALTER_POLICY (
    policy_name      IN  VARCHAR2,
    default_options  IN  VARCHAR2 DEFAULT NULL,
    column_name      IN  VARCHAR2 DEFAULT NULL);
```

Parameters

Table E-50 SA_SYSDBA.ALTER_POLICY Parameters

| Parameter | Description |
|--------------------------|--|
| <code>policy_name</code> | Specifies the policy. To find existing policies, query the <code>POLICY_NAME</code> column of the <code>ALL_SA_POLICIES</code> data dictionary view. |

Table E-50 (Cont.) SA_SYSDBA.ALTER_POLICY Parameters

| Parameter | Description |
|-----------------|--|
| default_options | Specifies the default enforcement options to be used when the policy is applied and no table- or schema-specific options are specified. Includes enforcement options and the option to hide the label column. Separate each option with a comma. See Categories of Policy Enforcement Options for a listing of the default enforcement options. |
| column_name | Specifies the column name associated with the policy. To find this column name, query the COLUMN_NAME column of the ALL_SA_POLICIES view. |

Example

The following example updates the `hr_ols_pol` policy to use a different set of default options. Because the name of the column does not need to change, the `column_name` parameter is omitted.

```
BEGIN
  SA_SYSDBA.ALTER_POLICY (
    policy_name      => 'hr_ols_pol',
    default_options => 'read_control, delete_control');
END;
/
```

SA_SYSDBA.CREATE_POLICY

The `SA_SYSDBA.CREATE_POLICY` procedure creates a new Oracle Label Security policy, defines a policy-specific column name, and specifies default policy options.

After you create the policy, a role for it is created and granted to you. The format of the role name is `policy_DBA` (for example, `my_ols_pol_DBA`).

Syntax

```
SA_SYSDBA.CREATE_POLICY (
  policy_name      IN VARCHAR2,
  column_name      IN VARCHAR2 DEFAULT NULL,
  default_options  IN VARCHAR2 DEFAULT NULL);
```

Parameters**Table E-51 SA_SYSDBA.CREATE_POLICY Parameters**

| Parameter | Description |
|-------------|---|
| policy_name | Specifies the policy name, which must be unique within the database. It can have a maximum of 30 characters, but only the first 26 characters in the <code>policy_name</code> are significant. Two policies may not have the same first 26 characters in the <code>policy_name</code> . To find a list of existing policies, query the <code>POLICY_NAME</code> column of the <code>ALL_SA_POLICIES</code> data dictionary view. |

Table E-51 (Cont.) SA_SYSDBA.CREATE_POLICY Parameters

| Parameter | Description |
|-----------------|--|
| column_name | Specifies the name of the column to be added to tables protected by the policy. If NULL, then the name <i>policy_name_COL</i> is used. Two Oracle Label Security policies cannot share the same column name. |
| default_options | Specifies the default options to be used when the policy is applied and no table- or schema-specific options are specified. Includes enforcement options and the option to hide the label column. Separate each option with a comma. See Categories of Policy Enforcement Options for a listing of the default enforcement options. |

Example

The following example creates a policy container whose default options are READ_CONTROL and WRITE_CONTROL. The WRITE_CONTROL option encompasses the INSERT_CONTROL, UPDATE_CONTROL, and DELETE_CONTROL options.

```
BEGIN
  SA_SYSDBA.CREATE_POLICY (
    policy_name      => 'hr_ols_pol',
    column_name     => 'ols_col',
    default_options => 'read_control, write_control');
END;
/
```

SA_SYSDBA.DISABLE_POLICY

The SA_SYSDBA.DISABLE_POLICY procedure turns off enforcement of a policy, without removing it from the database.

The policy is not enforced for all subsequent access to the database.

To disable a policy means that no access control is enforced on the tables and schemas protected by the policy. The administrator can continue to perform administrative operations while the policy is disabled.

**Note:**

This feature is extremely powerful, and should be used with caution. When a policy is disabled, anyone who connects to the database can access all the data normally protected by the policy. So, your site should establish guidelines for use of this feature.

Normally, a policy should not be disabled in order to manage data. At times, however, an administrator may need to disable a policy to perform application debugging tasks. In this case, the database should be run in single-user mode. In a development environment, for example, you may need to observe data processing operations without the policy turned on. When you reenables the policy, all of the selected enforcement options become effective again.

Syntax

```
SA_SYSDBA.DISABLE_POLICY (
  policy_name IN VARCHAR2);
```

Parameters**Table E-52 SA_SYSDBA.DISABLE_POLICY Parameters**

| Parameter | Description |
|-------------|---|
| policy_name | Specifies the policy. To find existing policies and their status, query the POLICY_NAME and STATUS columns of the ALL_SA_POLICIES data dictionary view. |

Example

The following example disables the hr_ols_pol policy:

```
EXEC SA_SYSDBA.DISABLE_POLICY ('hr_ols_pol');
```

SA_SYSDBA.DROP_POLICY

The SA_SYSDBA.DROP_POLICY procedure deletes the policy and its associated user labels and data labels from the database.

This procedure purges the policy and these associations from the system entirely. You can optionally drop the label column from all tables controlled by the policy. The policy does not need to be disabled before you drop it.

Syntax

```
SA_SYSDBA.DROP_POLICY (
  policy_name IN VARCHAR2,
  drop_column BOOLEAN DEFAULT FALSE);
```

Parameters**Table E-53 SA_SYSDBA.DROP_POLICY Parameters**

| Parameter | Description |
|-------------|--|
| policy_name | Specifies the policy to be dropped. To find existing policies, query the POLICY_NAME column of the ALL_SA_POLICIES data dictionary view. |
| drop_column | Indicates that the policy column should be dropped from protected tables (TRUE) |

Example

The following example deletes the hr_ols_pol policy.

```
EXEC SA_SYSDBA.DROP_POLICY ('hr_ols_pol');
```

SA_SYSDBA.ENABLE_POLICY

The `SA_SYSDBA.ENABLE_POLICY` procedure enforces access control on the tables and schemas protected by the policy.

A policy is automatically enabled when it is created. After creation or enablement, the policy is enforced for all subsequent access to tables protected by the policy.

Syntax

```
SA_SYSDBA.ENABLE_POLICY (policy_name IN VARCHAR2);
```

Parameters

Table E-54 SA_SYSDBA.ENABLE_POLICY Parameters

| Parameter | Description |
|--------------------------|--|
| <code>policy_name</code> | Specifies the policy. To find existing policies and their status, query the <code>POLICY_NAME</code> and <code>STATUS</code> columns of the <code>ALL_SA_POLICIES</code> data dictionary view. |

Example

The following example enables the `hr_ols_pol` policy.

```
EXEC SA_SYSDBA.ENABLE_POLICY('hr_ols_pol');
```

SA_USER_ADMIN PL/SQL Package

The `SA_USER_ADMIN` PL/SQL package manages user labels by label component.

- [About the SA_USER_ADMIN PL/SQL Package](#)
The `SA_USER_ADMIN` PL/SQL package configures compartments, groups, user access, labels, levels, and privileges.
- [SA_USER_ADMIN.ADD_COMPARTMENTS](#)
The `SA_USER_ADMIN.ADD_COMPARTMENTS` procedure adds (assigns) compartments to a user's authorizations, indicating if the compartments are authorized for write and read privileges.
- [SA_USER_ADMIN.ADD_GROUPS](#)
The `SA_USER_ADMIN.ADD_GROUPS` procedure adds (assigns) groups to a user, indicating if the groups are authorized for write and read privileges.
- [SA_USER_ADMIN.ALTER_COMPARTMENTS](#)
The `SA_USER_ADMIN.ALTER_COMPARTMENTS` procedure changes the write access, default label indicator, and row label indicator for the specified compartments.
- [SA_USER_ADMIN.ALTER_GROUPS](#)
The `SA_USER_ADMIN.ALTER_GROUPS` procedure changes the write access, default label indicator, and row label indicator for the specified groups.
- [SA_USER_ADMIN.DROP_ALL_COMPARTMENTS](#)
The `SA_USER_ADMIN.DROP_ALL_COMPARTMENTS` procedure drops all compartments from a user's authorizations.

- [SA_USER_ADMIN.DROP_ALL_GROUPS](#)
The `SA_USER_ADMIN.DROP_ALL_GROUPS` procedure drops all groups from a user's authorizations.
- [SA_USER_ADMIN.DROP_COMPARTMENTS](#)
The `SA_USER_ADMIN.DROP_COMPARTMENTS` procedure drops the specified compartments from a user's authorizations.
- [SA_USER_ADMIN.DROP_GROUPS](#)
The `SA_USER_ADMIN.DROP_GROUPS` procedure drops the specified groups from a user's authorizations.
- [SA_USER_ADMIN.DROP_USER_ACCESS](#)
The `SA_USER_ADMIN.DROP_USER_ACCESS` procedure removes all Oracle Label Security authorizations and privileges from the specified user.
- [SA_USER_ADMIN.SET_COMPARTMENTS](#)
The `SA_USER_ADMIN.SET_COMPARTMENTS` procedure assigns compartments to a user and identifies default values for the user's session label and row label.
- [SA_USER_ADMIN.SET_DEFAULT_LABEL](#)
The `SA_USER_ADMIN.SET_DEFAULT_LABEL` procedure sets the user's initial session label to the one specified.
- [SA_USER_ADMIN.SET_GROUPS](#)
The `SA_USER_ADMIN.SET_GROUPS` procedure assigns groups to a user and identifies default values for the user's session label and row label.
- [SA_USER_ADMIN.SET_LEVELS](#)
The `SA_USER_ADMIN.SET_LEVELS` procedure assigns a user minimum and maximum levels and identifies default values for the user's session label and row label.
- [SA_USER_ADMIN.SET_PROG_PRIVS](#)
The `SA_USER_ADMIN.SET_PROG_PRIVS` procedure sets policy-specific privileges for program units.
- [SA_USER_ADMIN.SET_ROW_LABEL](#)
The `SA_USER_ADMIN.SET_ROW_LABEL` procedure sets a user's initial row label to the one specified.
- [SA_USER_ADMIN.SET_USER_LABELS](#)
The `SA_USER_ADMIN.SET_USER_LABELS` procedure sets the user's levels, compartments, and groups using a set of labels, instead of the individual components.
- [SA_USER_ADMIN.SET_USER_PRIVS](#)
The `SA_USER_ADMIN.SET_USER_PRIVS` procedure sets policy-specific privileges for users.

About the SA_USER_ADMIN PL/SQL Package

The `SA_USER_ADMIN` PL/SQL package configures compartments, groups, user access, labels, levels, and privileges.

To use this package, you must be granted the `policy_DBA` role (for example, `HR_OLS_POL_DBA` for a role for the `hr_ols_pol` policy) and the `EXECUTE` privilege on the `SA_USER_ADMIN` package.

SA_USER_ADMIN.ADD_COMPARTMENTS

The `SA_USER_ADMIN.ADD_COMPARTMENTS` procedure adds (assigns) compartments to a user's authorizations, indicating if the compartments are authorized for write and read privileges.

This procedure is useful if you have already used the `SA_USER_ADMIN.SET_COMPARTMENTS` procedure for the user but then decide that you want to grant this user authorization for additional compartments, or to update the current set of compartments. You also can use it in place of `SA_USER_ADMIN.SET_COMPARTMENTS`.

Syntax

```
SA_USER_ADMIN.ADD_COMPARTMENTS (
policy_name      IN VARCHAR2,
user_name        IN VARCHAR2,
comps            IN VARCHAR2,
access_mode      IN VARCHAR2 DEFAULT NULL,
in_def           IN VARCHAR2 DEFAULT NULL,
in_row           IN VARCHAR2 DEFAULT NULL);
```

Parameters

Table E-55 SA_USER_ADMIN.ADD_COMPARTMENTS Parameters

| Parameter | Description |
|--------------------------|---|
| <code>policy_name</code> | Specifies the policy. To find existing policies, query the <code>POLICY_NAME</code> column of the <code>ALL_SA_POLICIES</code> data dictionary view. |
| <code>user_name</code> | Specifies the user name. This user can be either a new user or a user who has already been authorized for this policy's compartments. To find an existing user, query the <code>USER_NAME</code> column of the <code>DBA_SA_USER_COMPARTMENTS</code> view. |
| <code>comps</code> | A comma-delimited list of compartments to add, by short name only. To find existing compartments, query the <code>SHORT_NAME</code> column of the <code>ALL_SA_COMPARTMENTS</code> view. |
| <code>access_mode</code> | One of two public variables that contain string values that can specify the type of access authorized. The variable names, values, and meaning are as follows: <ul style="list-style-type: none"> <code>SA_UTL.READ_ONLY</code> indicates no write access <code>SA_UTL.READ_WRITE</code> indicates that write is authorized If <code>access_mode</code> is <code>NULL</code>, then it is set to <code>SA_UTL.READ_ONLY</code>. |
| <code>in_def</code> | Specifies whether these compartments should be in the default compartments (Y/N) If <code>in_def</code> is <code>NULL</code> , then it is set to <code>Y</code> . |
| <code>in_row</code> | Specifies whether these compartments should be in the row label (Y/N) If <code>in_row</code> is <code>NULL</code> , then it is set to <code>N</code> . |

Example

The following example adds compartments to the `hr_ols_pol` policy.

```

BEGIN
  SA_USER_ADMIN.ADD_COMPARTMENTS (
    policy_name => 'hr_ols_pol',
    user_name   => 'jjones',
    comps       => 'FIN',
    access_mode => SA_UTL.READ_ONLY,
    in_def      => 'y',
    in_row      => 'y');
END;
/

```

SA_USER_ADMIN.ADD_GROUPS

The `SA_USER_ADMIN.ADD_GROUPS` procedure adds (assigns) groups to a user, indicating if the groups are authorized for write and read privileges.

This procedure is useful if you have already used the `SA_USER_ADMIN.SET_GROUPS` procedure for the user but then decide that you want to grant this user authorization for additional groups or to update the current set of groups. You also can use it in place of `SA_USER_ADMIN.SET_GROUPS`.

Syntax

```

SA_USER_ADMIN.ADD_GROUPS (
  policy_name  IN VARCHAR2,
  user_name    IN VARCHAR2,
  groups       IN VARCHAR2,
  access_mode  IN VARCHAR2 DEFAULT NULL,
  in_def       IN VARCHAR2 DEFAULT NULL,
  in_row       IN VARCHAR2 DEFAULT NULL);

```

Parameters

Table E-56 SA_USER_ADMIN.ADD_GROUPS Parameters

| Parameter | Description |
|--------------------------|---|
| <code>policy_name</code> | Specifies the policy. To find existing policies, query the <code>POLICY_NAME</code> column of the <code>ALL_SA_POLICIES</code> data dictionary view. |
| <code>user_name</code> | Specifies the user. This user can be either a new user or a user who has already been authorized for this policy's groups. To find an existing user, query the <code>USER_NAME</code> column of the <code>DBA_SA_USER_GROUPS</code> view. |
| <code>groups</code> | A comma-delimited list of groups to add, by short name only. To find a list of existing groups, query the <code>SHORT_NAME</code> column of the <code>ALL_SA_GROUPS</code> view. |
| <code>access_mode</code> | One of two public variables that contain string values that can specify the type of access authorized. The variable names, values, and meaning are as follows: <ul style="list-style-type: none"> <code>SA_UTL.READ_ONLY</code> indicates no write access <code>SA_UTL.READ_WRITE</code> indicates that write is authorized If <code>access_mode</code> is <code>NULL</code>, then <code>access_mode</code> is set to <code>SA_UTL.READ_ONLY</code>. |
| <code>in_def</code> | Specifies whether these groups should be in the default groups (Y/N). If <code>in_def</code> is <code>NULL</code> , then it is set to <code>Y</code> . |

Table E-56 (Cont.) SA_USER_ADMIN.ADD_GROUPS Parameters

| Parameter | Description |
|-----------|--|
| in_row | Specifies whether these groups should be in the row label (Y/N) If in_row is NULL, then it is set to N. |

Example

The following example adds several groups to the hr_ols_pol policy.

```
BEGIN
  SA_USER_ADMIN.ADD_GROUPS (
    policy_name => 'hr_ols_pol',
    user_name   => 'jjones',
    groups      => 'ER_FIN, SR_FIN, NR_FIN, WR_FIN',
    access_mode => SA_UTL.READ_WRITE,
    in_def      => 'y',
    in_row      => 'y');
END;
/
```

SA_USER_ADMIN.ALTER_COMPARTMENTS

The SA_USER_ADMIN.ALTER_COMPARTMENTS procedure changes the write access, default label indicator, and row label indicator for the specified compartments.

Syntax

```
SA_USER_ADMIN.ALTER_COMPARTMENTS (
  policy_name IN VARCHAR2,
  user_name   IN VARCHAR2,
  comps       IN VARCHAR2,
  access_mode IN VARCHAR2 DEFAULT NULL,
  in_def      IN VARCHAR2 DEFAULT NULL,
  in_row      IN VARCHAR2 DEFAULT NULL);
```

Parameters

Table E-57 SA_USER_ADMIN.ALTER_COMPARTMENTS Parameters

| Parameter | Description |
|-------------|--|
| policy_name | Specifies the policy. To find existing policies, query the POLICY_NAME column of the ALL_SA_POLICIES data dictionary view. |
| user_name | Specifies the user who has been authorized for the compartment. To find authorized users, query the USER_NAME column of the DBA_SA_USER_COMPARTMENTS view. |
| comps | A comma-delimited list of compartments to modify, using the short name only. To find existing compartments, query the SHORT_NAME column of the ALL_SA_COMPARTMENTS view. |

Table E-57 (Cont.) SA_USER_ADMIN.ALTER_COMPARTMENTS Parameters

| Parameter | Description |
|-------------|--|
| access_mode | One of two public variables that contain string values that can specify the type of access authorized. The variable names, values, and meaning are as follows: SA_UTL.READ_ONLY indicates no write access SA_UTL.READ_WRITE indicates that write is authorized If access_mode is NULL, then access_mode for the compartment is unaltered. |
| in_def | Specifies whether these compartments should be in the default compartments (Y/N) If in_def is NULL, then in_def for the compartment is unaltered. |
| in_row | Specifies whether these compartments should be in the row label (Y/N) If in_row is NULL, then in_row for the compartment is unaltered. If in_def is N, then in_row cannot be Y. This is because the row label compartments must be a subset of the session label compartments. |

Example

The following example modifies compartments for the hr_ols_pol policy.

```
BEGIN
  SA_USER_ADMIN.ALTER_COMPARTMENTS (
    policy_name => 'hr_ols_pol',
    user_name   => 'jjones',
    comps       => 'FIN',
    access_mode => SA_UTL.READ_ONLY,
    in_def      => 'y',
    in_row      => 'y');
END;
/
```

SA_USER_ADMIN.ALTER_GROUPS

The SA_USER_ADMIN.ALTER_GROUPS procedure changes the write access, default label indicator, and row label indicator for the specified groups.

Syntax

```
SA_USER_ADMIN.ALTER_GROUPS (
  policy_name  IN VARCHAR2,
  user_name    IN VARCHAR2,
  groups       IN VARCHAR2,
  access_mode  IN VARCHAR2 DEFAULT NULL,
  in_def       IN VARCHAR2 DEFAULT NULL,
  in_row       IN VARCHAR2 DEFAULT NULL);
```

Parameters

Table E-58 SA_USER_ADMIN.ALTER_GROUPS Parameters

| Parameter | Description |
|-------------|--|
| policy_name | Specifies the policy. To find existing policies, query the POLICY_NAME column of the ALL_SA_POLICIES data dictionary view. |
| user_name | Specifies the user who has been authorized for the group. To find existing users, query the USER_NAME and GRP columns of the DBA_SA_USER_GROUPS view. |
| groups | A comma-delimited list of groups to alter, by short name only. To find existing groups, query the SHORT_NAME column of the ALL_SA_GROUPS view. |
| access_mode | Two public variables contain string values that can specify the type of access authorized. The variable names, values, and meaning are as follows: SA_UTL.READ_ONLY indicates no write access SA_UTL.READ_WRITE indicates that write is authorized If access_mode is NULL, then access_mode for the group is unaltered. |
| in_def | Specifies whether these groups should be in the default groups (Y/N) If in_def is NULL, then in_def for the group is unaltered. |
| in_row | Specifies whether these groups should be in the row label ((Y/N) If in_row is NULL, then in_row for the group is unaltered. If in_def is N, then in_row cannot be Y. This is because the row label groups must be a subset of the session label groups. |

Example

The following example sets the access mode for the existing groups to be read only.

```
BEGIN
  SA_USER_ADMIN.ALTER_GROUPS (
    policy_name => 'hr_ols_pol',
    user_name   => 'jjones',
    groups      => 'ER',
    access_mode => SA_UTL.READ_ONLY);
END;
/
```

SA_USER_ADMIN.DROP_ALL_COMPARTMENTS

The SA_USER_ADMIN.DROP_ALL_COMPARTMENTS procedure drops all compartments from a user's authorizations.

Syntax

```
SA_USER_ADMIN.DROP_ALL_COMPARTMENTS (
  policy_name IN VARCHAR2,
  user_name   IN VARCHAR2);
```

Parameters

Table E-59 SA_USER_ADMIN.DROP_ALL_COMPARTMENTS Parameters

| Parameter | Description |
|-------------|--|
| policy_name | Specifies the policy. To find existing policies, query the POLICY_NAME column of the ALL_SA_POLICIES data dictionary view. |
| user_name | Specifies the user who has been authorized for the compartment. To find existing users, query the USER_NAME column of the DBA_SA_USER_COMPARTMENTS view. |

Example

The following example drops all compartments for the hr_ols_pol policy for user jjones.

```
BEGIN
  SA_USER_ADMIN.DROP_ALL_COMPARTMENTS (
    policy_name => 'hr_ols_pol',
    user_name   => 'jjones');
END;
/
```

SA_USER_ADMIN.DROP_ALL_GROUPS

The SA_USER_ADMIN.DROP_ALL_GROUPS procedure drops all groups from a user's authorizations.

Syntax

```
SA_USER_ADMIN.DROP_ALL_GROUPS (
  policy_name IN VARCHAR2,
  user_name   IN VARCHAR2);
```

Parameters

Table E-60 SA_USER_ADMIN.DROP_ALL_GROUPS Parameters

| Parameter | Description |
|-------------|---|
| policy_name | Specifies the policy. To find existing policies, query the POLICY_NAME column of the ALL_SA_POLICIES data dictionary view. |
| user_name | Specifies the user who has been authorized for the group. To find existing users, query the USER_NAME and GRP columns of the DBA_SA_USER_GROUPS view. |

Example

The following example drops all groups from the hr_ols_pol policy for user jjones.

```
BEGIN
  SA_USER_ADMIN.DROP_ALL_GROUPS (
    policy_name => 'hr_ols_pol',
```

```

    user_name    => 'jjones');
END;
/

```

SA_USER_ADMIN.DROP_COMPARTMENTS

The `SA_USER_ADMIN.DROP_COMPARTMENTS` procedure drops the specified compartments from a user's authorizations.

Syntax

```

SA_USER_ADMIN.DROP_COMPARTMENTS (
    policy_name    IN VARCHAR2,
    user_name      IN VARCHAR2,
    comps          IN VARCHAR2);

```

Parameters

Table E-61 SA_USER_ADMIN.DROP_COMPARTMENTS Parameters

| Parameter | Description |
|--------------------------|--|
| <code>policy_name</code> | Specifies the policy. To find existing policies, query the <code>POLICY_NAME</code> column of the <code>ALL_SA_POLICIES</code> data dictionary view. |
| <code>user_name</code> | Specifies the user who has been authorized for the compartment. To find existing users, query the <code>USER_NAME</code> column of the <code>DBA_SA_USER_COMPARTMENTS</code> view. |
| <code>comps</code> | A comma-delimited list of compartments to drop. To find all comps for this policy, query the <code>POLICY_NAME</code> and <code>COMP</code> columns of the <code>DBA_SA_USER_COMPARTMENTS</code> view. |

Example

The following example drops the `FINANCIAL` compartment from the `hr_ols_pol` policy.

```

BEGIN
    SA_USER_ADMIN.DROP_COMPARTMENTS (
        policy_name => 'hr_ols_pol',
        user_name   => 'jjones',
        comps       => 'HR');
END;
/

```

SA_USER_ADMIN.DROP_GROUPS

The `SA_USER_ADMIN.DROP_GROUPS` procedure drops the specified groups from a user's authorizations.

Syntax

```

SA_USER_ADMIN.DROP_GROUPS (
    policy_name IN VARCHAR2,
    user_name  IN VARCHAR2,
    groups     IN VARCHAR2);

```

Parameters

Table E-62 SA_USER_ADMIN.DROP_GROUPS Parameters

| Parameter | Description |
|-------------|---|
| policy_name | Specifies the policy. To find existing policies, query the POLICY_NAME column of the ALL_SA_POLICIES data dictionary view. |
| user_name | Specifies the user who has been authorized for the group. To find existing users, query the USER_NAME and GRP columns of the DBA_SA_USER_GROUPS view. |
| groups | A comma-delimited list of groups to drop, by short name only. To find a list of groups, query the SHORT_NAME column of the ALL_SA_GROUPS view. |

Example

The following example drops the NR_FIN group from the hr_ols_pol policy.

```
BEGIN
  SA_USER_ADMIN.DROP_GROUPS (
    policy_name => 'hr_ols_pol',
    user_name   => 'jjones',
    groups      => 'ER');
END;
/
```

SA_USER_ADMIN.DROP_USER_ACCESS

The SA_USER_ADMIN.DROP_USER_ACCESS procedure removes all Oracle Label Security authorizations and privileges from the specified user.

Syntax

```
SA_USER_ADMIN.DROP_USER_ACCESS (
  policy_name  IN VARCHAR2,
  user_name    IN VARCHAR2);
```

Parameters

Table E-63 SA_USER_ADMIN.DROP_USER_ACCESS Parameters

| Parameter | Description |
|-------------|--|
| policy_name | Specifies the policy. To find existing policies, query the POLICY_NAME column of the ALL_SA_POLICIES data dictionary view. |
| user_name | Specifies the user name. To find all users associated with this policy, query the USER_NAME and POLICY_NAME columns of the DBA_SA_USER_PRIVS view. |

Examples

The following example removes user jjones's authorization for the hr_ols_pol policy.

```

BEGIN
  SA_USER_ADMIN.DROP_USER_ACCESS (
    policy_name      => 'hr_ols_pol',
    user_name        => 'jjones');
END;
/

```

SA_USER_ADMIN.SET_COMPARTMENTS

The `SA_USER_ADMIN.SET_COMPARTMENTS` procedure assigns compartments to a user and identifies default values for the user's session label and row label.

After you have set the compartment, you can configure additional compartments by using the `SA_USER_ADMIN.ADD_COMPARTMENTS` procedure. (See [SA_USER_ADMIN.ADD_COMPARTMENTS](#).)

All users must have their levels set before their authorized compartments can be established.

The write compartments, if specified, must be a subset of the read compartments. (The write compartments are those to which the user should have write access.)

Syntax

```

SA_USER_ADMIN.SET_COMPARTMENTS (
  policy_name  IN VARCHAR2,
  user_name    IN VARCHAR2,
  read_comps  IN VARCHAR2,
  write_comps IN VARCHAR2 DEFAULT NULL,
  def_comps   IN VARCHAR2 DEFAULT NULL,
  row_comps   IN VARCHAR2 DEFAULT NULL);

```

Parameters

Table E-64 SA_USER_ADMIN.SET_COMPARTMENTS Parameters

| Parameter | Description |
|--------------------------|--|
| <code>policy_name</code> | Specifies the policy. To find existing policies, query the <code>POLICY_NAME</code> column of the <code>ALL_SA_POLICIES</code> data dictionary view. |
| <code>user_name</code> | Specifies the user name to assign compartments |
| <code>read_comps</code> | A comma-delimited list of compartments authorized for read access, by short name only To find all compartments, query the <code>SHORT_NAME</code> column of the <code>ALL_SA_COMPARTMENTS</code> view. |
| <code>write_comps</code> | A comma-delimited list of compartments authorized for write access (subset of <code>read_comps</code>), by short name only. If <code>write_comps</code> are <code>NULL</code> , then they are set to the <code>read_comps</code> . |
| <code>def_comps</code> | Specifies the default compartments, by short name only. This must be a subset of <code>read_comps</code> . If the <code>def_comps</code> are <code>NULL</code> , then they are set to the <code>read_comps</code> . |
| <code>row_comps</code> | Specifies the row compartments, by short name only. This must be a subset of <code>write_comps</code> and <code>def_comps</code> . If the <code>row_comps</code> are <code>NULL</code> , then they are set to the components in <code>def_comps</code> that are authorized for write access. |

Example

The following example sets compartments for the `hr_ols_pol` policy.

```
BEGIN
  SA_USER_ADMIN.SET_COMPARTMENTS (
    policy_name => 'hr_ols_pol',
    user_name   => 'jjones',
    read_comps  => 'FIN',
    write_comps => 'FIN',
    def_comps   => 'FIN',
    row_comps   => 'FIN');
END;
/
```

SA_USER_ADMIN.SET_DEFAULT_LABEL

The `SA_USER_ADMIN.SET_DEFAULT_LABEL` procedure sets the user's initial session label to the one specified.

As long as the row label will still be dominated by the new write label, you can set the session label to:

- Any level equal to or less than his maximum, and equal to or greater than his minimum label
- Include any compartments in the authorized compartment list
- Include any groups in the authorized group list. (Subgroups of authorized groups are implicitly included in the authorized list.)

The row label must be dominated by the new write label that will result from resetting the session label. If this condition is not true, then the `SET_DEFAULT_LABEL` procedure will fail.

For example, suppose the current row label is `S:A,B`, and that you have write access to both compartments. If you attempt to set the new default label to `C:A,B`, then the `SET_LABEL` procedure will fail. This is because the new write label would be `C:A,B`, which does not dominate the current row label.

To successfully reset the session label in this case, you must first lower the row label to a value that will be dominated by the resulting session label.

Syntax

```
SA_USER_ADMIN.SET_DEFAULT_LABELS (
  policy_name IN VARCHAR2,
  user_name   IN VARCHAR2,
  def_label   IN VARCHAR2);
```

Parameters

Table E-65 SA_USER_ADMIN.SET_DEFAULT_LABEL Parameters

| Parameter | Description |
|-------------|---|
| policy_name | Specifies the policy. To find existing policies, query the POLICY_NAME column of the ALL_SA_POLICIES data dictionary view. |
| user_name | Specifies the user who has been authorized with label components. To find this user, query the USER_NAME column of the ALL_SA_USER_LABELS view. |
| def_label | Specifies the label string to be used to initialize the user's default labels. This label may contain any compartments and groups that are authorized for read access. To find existing labels, query the LABEL column of the ALL_SA_LABELS view. |

Example

The following example sets the default label for hr_ols_pol for user jjones.

```
BEGIN
  SA_USER_ADMIN.SET_DEFAULT_LABEL (
    policy_name    => 'hr_ols_pol',
    user_name      => 'jjones',
    def_label      => 'HS');
END;
/
```

Related Topics

- [SA_SESSION Session Management PL/SQL Package](#)
The SA_SESSION PL/SQL package manages session behavior for user authorizations.

SA_USER_ADMIN.SET_GROUPS

The SA_USER_ADMIN.SET_GROUPS procedure assigns groups to a user and identifies default values for the user's session label and row label.

All users must have their levels set before their authorized groups can be established. You can find information about a user's level authorization by querying the DBA_SA_USER_LEVELS data dictionary view.

Syntax

```
SA_USER_ADMIN.SET_GROUPS (policy_name IN VARCHAR2,
  user_name          IN VARCHAR2,
  read_groups        IN VARCHAR2,
  write_groups       IN VARCHAR2 DEFAULT NULL,
  def_group          IN VARCHAR2 DEFAULT NULL,
  row_groups         IN VARCHAR2 DEFAULT NULL);
```

Parameters

Table E-66 SA_USER_ADMIN.SET_GROUPS Parameters

| Parameter | Description |
|---------------------------|--|
| <code>policy_name</code> | Specifies the policy. To find existing policies, query the <code>POLICY_NAME</code> column of the <code>ALL_SA_POLICIES</code> data dictionary view. |
| <code>user_name</code> | Specifies the user name. This user is a first-time user for group authorization, but the user must already be authorized for levels. To find users who have been authorized for levels, query the <code>USER_NAME</code> column of the <code>DBA_SA_USER_LEVELS</code> view. |
| <code>read_groups</code> | A comma-delimited list of groups authorized for read, by short name only. To find existing groups, query the <code>SHORT_NAME</code> column of the <code>ALL_SA_GROUPS</code> view. |
| <code>write_groups</code> | A comma-delimited list of groups authorized for write, by short name only. This must be a subset of <code>read_groups</code> . If set to <code>NULL</code> , then this setting defaults to <code>read_groups</code> . |
| <code>def_groups</code> | Specifies the default groups, by short name only. This must be a subset of <code>read_groups</code> . If set to <code>NULL</code> , then this setting defaults to <code>read_groups</code> . |
| <code>row_groups</code> | Specifies the row groups, by short name only. This must be a subset of <code>write_groups</code> and <code>def_groups</code> . If set to <code>NULL</code> , then this setting defaults to the groups in <code>def_groups</code> that are authorized for write access. |

Example

The following example defines groups for the `hr_ols_pol` policy.

```
BEGIN
  SA_USER_ADMIN.SET_GROUPS (
    policy_name => 'hr_ols_pol',
    user_name   => 'jjones',
    read_groups => 'ER_FIN',
    write_groups => 'ER_FIN',
    def_groups  => 'ER_FIN',
    row_groups  => 'ER_FIN');
END;
/
```

SA_USER_ADMIN.SET_LEVELS

The `SA_USER_ADMIN.SET_LEVELS` procedure assigns a user minimum and maximum levels and identifies default values for the user's session label and row label.

Syntax

```
SA_USER_ADMIN.SET_LEVELS (policy_name IN VARCHAR2,
  user_name           IN VARCHAR2,
  max_level           IN VARCHAR2,
  min_level           IN VARCHAR2 DEFAULT NULL,
```

```
def_level      IN VARCHAR2 DEFAULT NULL,
row_level      IN VARCHAR2 DEFAULT NULL);
```

Parameters

Table E-67 SA_USER_ADMIN.SET_LEVELS Parameters

| Parameter | Description |
|-------------|--|
| policy_name | Specifies the policy. To find existing policies, query the POLICY_NAME column of the ALL_SA_POLICIES data dictionary view. |
| user_name | Specifies the user name. This user does not need to have any Oracle Label Security authorizations before you run this procedure. |
| max_level | The highest level for read and write access, by short name only. To find existing levels, query the SHORT_NAME column of the ALL_SA_LEVELS view. |
| min_level | The lowest level for write access, by short name only. If set to NULL, then the default is the lowest level for the policy. |
| def_level | Specifies the default level (equal to or greater than the minimum level, and equal to or less than the maximum level). Use the short name only. If set to NULL, then the default is the max_level. |
| row_level | Specifies the row level (equal to or greater than the minimum level, and equal to or less than the default level). Use the short name only. If set to NULL, then it is set to the def_level. |

Example

The following example sets levels for the `hr_ols_pol` policy.

```
BEGIN
  SA_USER_ADMIN.SET_LEVELS (
    policy_name => 'hr_ols_pol',
    user_name   => 'jjones',
    max_level   => 'PUB',
    min_level   => 'HS');
END;
/
```

SA_USER_ADMIN.SET_PROG_PRIVS

The `SA_USER_ADMIN.SET_PROG_PRIVS` procedure sets policy-specific privileges for program units.

If the `privileges` parameter is `NULL`, then the program unit's privileges for the policy are removed.

To grant privileges to a stored program unit, you must have the `policy_DBA` role, and the `EXECUTE` permission on the `SA_USER_ADMIN.SA_USER_ADMIN` package. You can use either the `SA_USER_ADMIN` package or Oracle Enterprise Manager to manage Oracle Label Security privileges.

Syntax

```
SA_USER_ADMIN.SET_PROG_PRIVS (
  policy_name          IN VARCHAR2,
  schema_name         IN VARCHAR2,
  program_unit_name   IN VARCHAR2,
  privileges           IN VARCHAR2);
```

Parameters

Table E-68 SA_SESSION.SET_LABEL Parameters

| Parameter | Description |
|-------------------|---|
| policy_name | Specifies the policy. To find existing policies, query the POLICY_NAME column of the ALL_SA_POLICIES data dictionary view. |
| schema_name | The name of the schema that contains the program unit |
| program_unit_name | Specifies the program unit to be granted privileges |
| privileges | A comma-delimited character string of policy-specific privileges. If you set privileges to NULL, then the program unit's privileges for the policy are removed. See About Granting Privileges to Users and Trusted Program Units for the Policy for list of available privileges to grant. |

Example

The following example gives the READ privilege to the SUM_PURCHASES function (described in [Example: Trusted Stored Program Unit](#)):

```
BEGIN
  SA_USER_ADMIN.SET_PROG_PRIVS (
    policy_name          => 'hr_ols_pol',
    schema_name         => 'HR',
    program_unit_name   => 'check_emp_hours',
    privileges           => 'READ');
END;
/
```

When the check_emp_hours procedure is then called, it runs with the READ privilege as well as the current user's Oracle Label Security privileges. Using this technique, the user can be allowed to find the value of the total employee hours that were logged, without learning what hours any individual employee logged.

SA_USER_ADMIN.SET_ROW_LABEL

The SA_USER_ADMIN.SET_ROW_LABEL procedure sets a user's initial row label to the one specified.

The user can set the row label independently, but only to:

- A level that is less than or equal to the level of the session label, and greater than or equal to the user's minimum level
- Include a subset of the compartments and groups from the session label, for which the user is authorized to have write access

If you try to set the row label to an invalid value, then the operation is disallowed, and the row label value is unchanged.

Syntax

```
SA_USER_ADMIN.SET_ROW_LABEL (
  policy_name  IN VARCHAR2,
  user_name    IN VARCHAR2,
  row_label    IN VARCHAR2);
```

Parameters

Table E-69 SA_USER_ADMIN.SET_ROW_LABEL Parameters

| Parameter | Description |
|-------------|---|
| policy_name | Specifies the policy. To find existing policies, query the POLICY_NAME column of the ALL_SA_POLICIES data dictionary view. |
| user_name | Specifies the user name. This user must have the sufficient compartment, group, and level authorizations. To find this user, query the USER_NAME column of the DBA_SA_USER_COMPARTMENTS, DBA_SA_USER_GROUPS, and DBA_SA_USER_LEVELS views. |
| row_label | Specifies the label string to be used to initialize the user's row label. The label must contain only those compartments and groups from the default label that are authorized for write access. To find existing compartments and groups, query the ALL_SA_COMPARTMENTS and ALL_SA_GROUPS views. |

Example

The following example sets the row label for the hr_ols_pol policy for user jjones.

```
BEGIN
  SA_USER_ADMIN.SET_ROW_LABEL (
    policy_name => 'hr_ols_pol',
    user_name   => 'jjones',
    row_label   => 'HS');
END;
/
```

Related Topics

- [SA_SESSION.SET_ROW_LABEL](#)
The SA_SESSION.SET_ROW_LABEL procedure sets the default row label value for the current database session.

SA_USER_ADMIN.SET_USER_LABELS

The SA_USER_ADMIN.SET_USER_LABELS procedure sets the user's levels, compartments, and groups using a set of labels, instead of the individual components.

Syntax

```
SA_USER_ADMIN.SET_USER_LABELS (
  policy_name  IN VARCHAR2,
  user_name    IN VARCHAR2,
```

```

max_read_label  IN VARCHAR2,
max_write_label IN VARCHAR2 DEFAULT NULL,
min_write_label IN VARCHAR2 DEFAULT NULL,
def_label       IN VARCHAR2 DEFAULT NULL,
row_label       IN VARCHAR2 DEFAULT NULL);

```

Parameters

Table E-70 SA_USER_ADMIN.SET_USER_LABELS Parameters

| Parameter | Description |
|-----------------|---|
| policy_name | Specifies the policy. To find existing policies, query the POLICY_NAME column of the ALL_SA_POLICIES data dictionary view. |
| user_name | Specifies the user name. The user can be an existing database user, a Real Application Security user, or any named user that resides in Oracle Internet Directory. This user does not need any Oracle Label Security authorizations before you run this procedure. |
| max_read_label | Specifies the label string to be used to initialize the user's maximum authorized read label. Composed of the user's maximum level, compartments authorized for read access, and groups authorized for read access. To find information for these settings, query the DBA_SA_USERS data dictionary view. |
| max_write_label | Specifies the label string to be used to initialize the user's maximum authorized write label. Composed of the user's maximum level, compartments authorized for write access, and groups authorized for write access. If max_write_label is not specified, then it is set to max_read_label. |
| min_write_label | Specifies the label string to be used to initialize the user's minimum authorized write label. Contains only the level, with no compartments or groups. If min_write_label is not specified, then it is set to the lowest defined level for the policy, with no compartments or groups. |
| def_label | Specifies the label string to be used to initialize the user's session label, including level, compartments, and groups (a subset of max_read_label). If default_label is not specified, then it is set to max_read_label. |
| row_label | Specifies the label string to be used to initialize the program's row label. Includes level, components, and groups: subsets of max_write_label and def_label. If row_label is not specified, then it is set to def_label, with only the compartments and groups authorized for write access. |

Examples

The following example sets user labels for the hr_ols_pol policy for user jjones.

```

BEGIN
  SA_USER_ADMIN.SET_USER_LABELS (
    policy_name => 'hr_ols_pol',
    user_name   => 'jjones',
    max_read_label => 'HS:FIN',
    max_write_label => 'HS',
    def_label    => 'HS',

```

```

    row_label      => 'HS');
END;
/

```

The following example sets user labels for the `XSOLSPOL1` policy for the Oracle Database Real Application Security user `XSUSER1`. To execute the following example, you must either be an administrative user named `LBACSYS`, be granted the `LBAC_DBA` database role and granted the `EXECUTE` privilege, or be granted the `XSOLSPOL1_DBA` role and granted the `EXECUTE` privilege on the `SA_USER_ADMIN` package.

```
EXEC SA_USER_ADMIN.SET_USER_LABELS('XSOLSPOL1', 'XSUSER1','MID','MID');
```

In this specification:

- `XSOLSPOL1` is the name of an existing OLS policy.
- `XSUSER1` is the name of an existing Oracle Database Real Application Security user.
- `MID` is the value of the `max_read_label`.
- `MID` is the value of the `max_write_label`.

Related Topics

- [SA_USER_ADMIN.SET_PROG_PRIVS](#)
The `SA_USER_ADMIN.SET_PROG_PRIVS` procedure sets policy-specific privileges for program units.

SA_USER_ADMIN.SET_USER_PRIVS

The `SA_USER_ADMIN.SET_USER_PRIVS` procedure sets policy-specific privileges for users.

These privileges do not become effective until the next time the user logs into the database. The new set of privileges replaces any existing privileges. A `NULL` value for the `privileges` parameter removes the user's privileges for the policy.

To assign policy privileges to users, you must have the `EXECUTE` privilege for the `SA_USER_ADMIN` package, and must have been granted the `policy_DBA` role.

Syntax

```
SA_USER_ADMIN.SET_USER_PRIVS (
    policy_name      IN VARCHAR2,
    user_name        IN VARCHAR2,
    privileges        IN VARCHAR2);
```

Parameters

Table E-71 SA_USER_ADMIN.SET_USER_PRIVS Parameters

| Parameter | Description |
|--------------------------|--|
| <code>policy_name</code> | Specifies the policy. To find existing policies, query the <code>POLICY_NAME</code> column of the <code>ALL_SA_POLICIES</code> data dictionary view. |

Table E-71 (Cont.) SA_USER_ADMIN.SET_USER_PRIVS Parameters

| Parameter | Description |
|------------|--|
| user_name | The name of the user to be granted privileges. The user can be an existing database user, a Real Application Security user, or any named user that resides in Oracle Internet Directory. This user should already have been authorized for policy levels, compartments, and groups. To find this user, query the USER_NAME column of the DBA_SA_USER_COMPARTMENTS, DBA_SA_USER_GROUPS, and DBA_SA_USER_LABELS views. |
| privileges | A character string of policy-specific privileges separated by commas. See About Granting Privileges to Users and Trusted Program Units for the Policy for list of available privileges to grant. |

Examples

The following example grants user `jgodfrey` full privileges for the `hr_ols_pol` policy settings.

```
BEGIN
  SA_USER_ADMIN.SET_USER_PRIVS (
    policy_name    => 'hr_ols_pol',
    user_name      => 'jgodfrey',
    privileges     => 'FULL');
END;
/
```

The following example grants Oracle Database Real Application Security user `XSUSER1` the `READ` privilege for the Oracle Label Security policy `XSOLSPOL1`. To execute the following example, you must either be an administrative user named `LBACSYS`, be granted the `LBAC_DBA` database role and granted the `EXECUTE` privilege, or be granted the `XSOLSPOL1_DBA` role and granted the `EXECUTE` privilege on the `SA_USER_ADMIN` package.

```
EXEC SA_USER_ADMIN.SET_USER_PRIVS('XSOLSPOL1', 'XSUSER1', 'READ');
```

In this specification:

- `XSOLSPOL1` is the name of an existing OLS policy.
- `XSUSER1` is the name of an existing Oracle Database Real Application Security user.
- `READ` is the privilege to be granted to `XSUSER1` in OLS policy `XSOLSPOL1`.

Related Topics

- [About Granting Privileges to Users and Trusted Program Units for the Policy](#)
After you have authorized users for policy levels, compartments, and groups, you are ready to grant the user privileges.

SA_UTL PL/SQL Utility Functions and Procedures

The `SA_UTL` PL/SQL package contains utility functions and procedures that are used in PL/SQL programs.

- [About the SA_UTL PL/SQL Package](#)
The SA_UTL PL/SQL package utility functions include returning the values such as user privileges or label information.
- [SA_UTL.CHECK_LABEL_CHANGE](#)
The SA_UTL.CHECK_LABEL_CHANGE function checks if the user can change the data label for a policy protected table row.
- [SA_UTL.CHECK_READ](#)
The SA_UTL.CHECK_READ function checks if a user can read a policy-protected table row.
- [SA_UTL.CHECK_WRITE](#)
The SA_UTL.CHECK_WRITE function to checks if the user can insert, update, or delete data in a policy protected table row.
- [SA_UTL.DATA_LABEL](#)
The SA_UTL.DATA_LABEL function returns TRUE if the label is a data label.
- [SA_UTL.GREATEST_LBOUND](#)
The SA_UTL.GREATEST_LBOUND function returns a label that is the greatest lower bound of the two label arguments.
- [SA_UTL.LEAST_UBOUND](#)
The SA_UTL.LEAST_UBOUND function returns a label that is the least upper bound of the label arguments.
- [SA_UTL.NUMERIC_LABEL](#)
The SA_UTL.NUMERIC_LABEL function returns the current session label.
- [SA_UTL.NUMERIC_ROW_LABEL](#)
The SA_UTL.NUMERIC_ROW_LABEL function returns the current row label. .
- [SA_UTL.SET_LABEL](#)
The SA_UTL.SET_LABEL procedure sets the label of the current database session.
- [SA_UTL.SET_ROW_LABEL](#)
The SA_UTL.SET_ROW_LABEL procedure sets the row label of the current database session.

About the SA_UTL PL/SQL Package

The SA_UTL PL/SQL package utility functions include returning the values such as user privileges or label information.

These programs return information about the current values of the session security attributes, as numeric label values. They are primarily for use in trusted stored program units. You do not need special privileges to use this package.

Related Topics

- [How Setting and Returning Label Information Works](#)
The SA_UTL package has functions to return information about current values of session security attributes using numeric label values.

SA_UTL.CHECK_LABEL_CHANGE

The `SA_UTL.CHECK_LABEL_CHANGE` function checks if the user can change the data label for a policy protected table row.

This function returns 1 if the user can change the data label. It returns 0 if the user cannot change the data label. The input values are the policy name, the current data label, and the new data label.

Syntax

```
SA_UTL.CHECK_LABEL_CHANGE (  
  policy_name      IN VARCHAR2,  
  current_label    IN NUMBER,  
  new_label        IN NUMBER)  
RETURN NUMBER;
```

Note:

You must have update privileges on the table to write any data into the table.

Parameters

Table E-72 SA_UTL.CHECK_LABEL_CHANGE Parameters

| Parameter | Description |
|----------------------------|--|
| <code>policy_name</code> | Specifies the policy. To find existing policies, query the <code>POLICY_NAME</code> column of the <code>ALL_SA_POLICIES</code> data dictionary view. |
| <code>current_label</code> | The current value of the label. To find existing label values, query the <code>LABEL</code> column of the <code>ALL_SA_LABELS</code> view. |
| <code>new_label</code> | The new value for the label |

Example

The following example indicates if users can change data labels in policy-protected rows.

```
SET SERVEROUTPUT ON  
BEGIN  
  IF SA_UTL.CHECK_LABEL_CHANGE('hr_ols_pol',2000, 2200) = 1  
    THEN DBMS_OUTPUT.PUT_LINE('Users can chagne data labels in policy-protected  
rows.');
```

```
  ELSE  
    DBMS_OUTPUT.PUT_LINE('Users cannot change data labels in policy-protected rows.');
```

```
  END IF;  
END;  
/
```

SA_UTL.CHECK_READ

The `SA_UTL.CHECK_READ` function checks if a user can read a policy-protected table row.

This function returns 1 if the user can read the table row. It returns 0 if the user cannot read the table row.



Note:

The user must have the `SELECT` privilege on the table to read any data from the table.

Syntax

```
SA_UTL.CHECK_READ (
  policy_name    IN VARCHAR2,
  label          IN NUMBER)
RETURN NUMBER;
```

Parameters

Table E-73 SA_UTL.CHECK_READ Parameters

| Parameter | Description |
|--------------------------|--|
| <code>policy_name</code> | Specifies the policy. To find existing policies, query the <code>POLICY_NAME</code> column of the <code>ALL_SA_POLICIES</code> data dictionary view. |
| <code>label</code> | The label to be checked. To find existing label values, query the <code>LABEL</code> column of the <code>ALL_SA_LABELS</code> view. |

Example

The following example indicates if users can read a policy-protected row.

```
SET SERVEROUTPUT ON
BEGIN
  IF SA_UTL.CHECK_READ('hr_ols_pol',2000) = 1
  THEN DBMS_OUTPUT.PUT_LINE('Users can read policy-protected rows.');
```

```
ELSE
  DBMS_OUTPUT.PUT_LINE('Users cannot read policy-protected rows.');
```

```
END IF;
END;
```

```
/
```

SA_UTL.CHECK_WRITE

The `SA_UTL.CHECK_WRITE` function checks if the user can insert, update, or delete data in a policy-protected table row.

The user should already have the `UPDATE` privilege on the table to write any data into the table. This function returns 1 if the user can write to the table row. It returns 0 if the

user cannot write to the table row. The input values are the policy name and the row data label.

Syntax

```
SA_UTL.CHECK_WRITE (
    policy_name    IN VARCHAR2,
    label          IN NUMBER)
RETURN NUMBER;
```

Parameters

Table E-74 SA_UTL.CHECK_WRITE Parameters

| Parameter | Description |
|-------------|--|
| policy_name | Specifies the policy. To find existing policies, query the POLICY_NAME column of the ALL_SA_POLICIES data dictionary view. |
| label | The label to be checked. To find existing label values, query the LABEL and TAG columns of the ALL_SA_LABELS view. |

Example

The following example indicates if users can write to policy-protected rows.

```
SET SERVEROUTPUT ON
BEGIN
    IF SA_UTL.CHECK_WRITE('hr_ols_pol',2000) = 1
    THEN DBMS_OUTPUT.PUT_LINE('Users can write to policy-protected rows.');
```

```
ELSE
    DBMS_OUTPUT.PUT_LINE('Users cannot write to policy-protected rows.');
```

```
END IF;
END;
/
```

SA_UTL.DATA_LABEL

The SA_UTL.DATA_LABEL function returns TRUE if the label is a data label.

Syntax

```
SA_UTL.DATA_LABEL(
    label IN NUMBER)
RETURN BOOLEAN;
```

Parameters

Table E-75 SA_UTL.DATA_LABEL Parameter

| Parameter | Description |
|-----------|--|
| label | The label to be checked. To find existing label values, query the LABEL and TAG columns of the ALL_SA_LABELS view. |

Example

The following example indicates if the label 2000 is a data label.

```

SET SERVEROUTPUT ON
BEGIN
  IF SA_UTL.DATA_LABEL(2000)
    THEN DBMS_OUTPUT.PUT_LINE('Label 2000 is a data label. ');
  ELSE
    DBMS_OUTPUT.PUT_LINE('Label 2000 is not a data label. ');
  END IF;
END;
/

```

SA_UTL.GREATEST_LBOUND

The `SA_UTL.GREATEST_LBOUND` function returns a label that is the greatest lower bound of the two label arguments.

Syntax

```

SA_UTL.GREATEST_LBOUND (
  label1 IN NUMBER,
  label2 IN NUMBER)
RETURN NUMBER;

```

Parameters

Table E-76 SA_UTL.GREATEST_LBOUND Parameters

| Parameter | Description |
|-----------|---|
| label1 | The first label to check. To find existing label values, query the LABEL and TAG columns of the ALL_SA_LABELS view. |
| label2 | The second label to check |

Examples

The following example compares existing label tags 3110 and 3111.

```

SELECT SA_UTL.GREATEST_LBOUND(3110,3111) FROM DUAL;

SA_UTL.GREATEST_LBOUND(3110,3111)
-----
                                3111

```

SA_UTL.LEAST_UBOUND

The `SA_UTL.LEAST_UBOUND` function returns a label that is the least upper bound of the label arguments.

Syntax

```

SA_UTL.LEAST_UBOUND (
  label1 IN NUMBER,
  label2 IN NUMBER)
RETURN NUMBER;

```

Parameters

Table E-77 SA_UTL.LEAST_UBOUND Parameters

| Parameter | Description |
|-----------|---|
| label1 | The first label to check. To find existing label values, query the LABEL and TAG columns of the ALL_SA_LABELS view. |
| label2 | The second label to check |

Example

The following example compares existing labels 3110 and 3111.

```
SELECT SA_UTL.LEAST_UBOUND(3110,3111) FROM DUAL;

SA_UTL.LEAST_UBOUND(3110,3111)
-----
                             3110
```

See Also:

[Determination of the Upper and Lower Bounds of Labels](#). The functions described here are the same as those described in that topic, except that these return a number instead of a character string.

SA_UTL.NUMERIC_LABEL

The SA_UTL.NUMERIC_LABEL function returns the current session label.

This function takes a policy name as the input parameter and returns a NUMBER value.

Syntax

```
SA_UTL.NUMERIC_LABEL (
    policy_name)
RETURN NUMBER;
```

Parameters

Table E-78 SA_UTL.NUMERIC_LABEL Parameter

| Parameter | Description |
|-------------|--|
| policy_name | Specifies the policy. To find existing policies, query the POLICY_NAME column of the ALL_SA_POLICIES data dictionary view. |

Example

The following example returns a the session numeric label for the user who is currently connected to the database instance.

```

SET SERVEROUTPUT ON
DECLARE
  num_label number;
BEGIN
  num_label := SA_UTL.NUMERIC_LABEL('hr_ols_pol');
  DBMS_OUTPUT.PUT_LINE('Numeric label: '||num_label);
END;
/

```

SA_UTL.NUMERIC_ROW_LABEL

The `SA_UTL.NUMERIC_ROW_LABEL` function returns the current row label. .

This function takes a policy name as the input parameter and returns a `NUMBER` value

Syntax

```

SA_UTL.NUMERIC_ROW_LABEL (
  policy_name)
RETURN NUMBER;

```

Parameters

Table E-79 SA_UTL.NUMERIC_ROW_LABEL Parameters

| Parameter | Description |
|--------------------------|--|
| <code>policy_name</code> | Specifies the policy. To find existing policies, query the <code>POLICY_NAME</code> column of the <code>ALL_SA_POLICIES</code> data dictionary view. |

Examples

The following example returns the session numeric row label for the user who is currently connected to the database instance.

```

SET SERVEROUTPUT ON
DECLARE
  num_row number;
BEGIN
  num_row := SA_UTL.NUMERIC_ROW_LABEL('hr_ols_pol');
  DBMS_OUTPUT.PUT_LINE('Numeric row label: '||num_row);
END;
/

```

SA_UTL.SET_LABEL

The `SA_UTL.SET_LABEL` procedure sets the label of the current database session.

The session's write label and row label are set to the subset of the label's compartments and groups that are authorized for write access.

Syntax

```

SA_UTL.SET_LABEL (
  policy_name IN VARCHAR2,
  label       IN LBAC_LABEL);

```

Parameters

Table E-80 SA_UTL.SET_LABEL Parameters

| Parameter | Description |
|-------------|--|
| policy_name | Specifies the policy. To find existing policies, query the POLICY_NAME column of the ALL_SA_POLICIES data dictionary view. |
| label | The label to set as the session label. To find existing label values, query the LABEL column of the ALL_SA_LABELS view. You must pass this parameter through as an output of the TO_LBAC_DATA_LABEL function, which converts a label in character form to an LBAC_LABEL type. (The example in the next section shows how to do this.) |

Example

The following example sets the label for the hr_ols_pol policy.

```
BEGIN
  SA_UTL.SET_LABEL (
    policy_name => 'hr_ols_pol',
    label       => to_lbac_data_label('hr_ols_pol', 'hs:pii'));
END;
/
```

Related Topics

- [How Labeling Functions in Oracle Label Security Policies Works](#)
Labeling functions enable you to consider, in your rules for assigning labels, information drawn from the application context.

SA_UTL.SET_ROW_LABEL

The SA_UTL.SET_ROW_LABEL procedure sets the row label of the current database session.

The compartments and groups in the label must be a subset of compartments and groups in the session label that are authorized for write access.

Syntax

```
SA_UTL.SET_ROW_LABEL (
  policy_name IN VARCHAR2,
  label       IN BINARY_INTEGER);
```

Parameters

Table E-81 SA_UTL.SET_ROW_LABEL Parameters

| Parameter | Description |
|-------------|--|
| policy_name | Specifies the policy. To find existing policies, query the POLICY_NAME column of the ALL_SA_POLICIES data dictionary view. |

Table E-81 (Cont.) SA_UTL.SET_ROW_LABEL Parameters

| Parameter | Description |
|-----------|---|
| label | The label to set as the session default row label. To find existing label values, query the LABEL column of the ALL_SA_LABELS view. |

Example

The following example sets the row label for the hr_ols_pol policy to 3000.

```
BEGIN
  SA_UTL.SET_ROW_LABEL (
    policy_name      => 'hr_ols_pol',
    label            => 1111);
END;
/
```

Related Topics

- [SA_SESSION Session Management PL/SQL Package](#)
 The SA_SESSION PL/SQL package manages session behavior for user authorizations.

F

Oracle Label Security Reference

Oracle Label Security provides data dictionary tables and views. You should also be aware of Oracle Label Security restrictions.

- [Oracle Label Security Data Dictionary Tables and Views](#)
Oracle Label Security provides data dictionary tables, data dictionary views, and an user-created auditing view.
- [Restrictions in Oracle Label Security](#)
Several restrictions exist in this Oracle Label Security release.

Oracle Label Security Data Dictionary Tables and Views

Oracle Label Security provides data dictionary tables, data dictionary views, and an user-created auditing view.

- [Oracle Database Data Dictionary Tables](#)
Oracle Label Security does not label the Oracle data dictionary tables; access is controlled by standard Oracle Database system and object privileges.
- [Oracle Label Security Data Dictionary Views](#)
Oracle Label Security maintains an independent set of data dictionary views, which are exempt from any policy enforcement.
- [Oracle Label Security User-Created Auditing View](#)
The `SA_AUDIT_ADMIN.CREATE_VIEW` procedure can be used to create an audit trail view for a specific policy.

Oracle Database Data Dictionary Tables

Oracle Label Security does not label the Oracle data dictionary tables; access is controlled by standard Oracle Database system and object privileges.

See Also:

Oracle Database Reference for detailed information about all data dictionary tables and views

Oracle Label Security Data Dictionary Views

Oracle Label Security maintains an independent set of data dictionary views, which are exempt from any policy enforcement.

Access to the data dictionary views is granted by default to the `SELECT_CATALOG_ROLE`, a standard Oracle Database role that lets you examine the Oracle Database data dictionary.

- [ALL_SA_AUDIT_OPTIONS View](#)
The `ALL_SA_AUDIT_OPTIONS` data dictionary view shows for the current user Oracle Label Security auditing options, based on the `SA_AUDIT_ADMIN.AUDIT` procedure settings.
- [ALL_SA_COMPARTMENTS](#)
The `ALL_SA_COMPARTMENTS` data dictionary view shows information for the current user about Oracle Label Security policy compartments, based on the `SA_COMPONENTS.CREATE_COMPARTMENT` procedure settings.
- [ALL_SA_DATA_LABELS](#)
The `ALL_SA_DATA_LABELS` data dictionary view shows for the current user Oracle Label Security policy labels and tags, based on the `SA_LABEL_ADMIN.CREATE_LABEL` procedure settings.
- [ALL_SA_GROUPS](#)
The `ALL_SA_GROUPS` data dictionary shows information about the current user's Oracle Label Security policy groups, based on the `SA_COMPONENTS.CREATE_GROUP` and `SA_COMPONENTS.ALTER_GROUP_PARENT` procedures.
- [ALL_SA_LABELS](#)
The `ALL_SA_LABELS` data dictionary view shows for the current user information about the tags and types of labels, based on `SA_LABEL_ADMIN.CREATE_LABEL` and `SA_LABEL_ADMIN.ALTER_LABEL`.
- [ALL_SA_LEVELS](#)
The `ALL_SA_LEVELS` data dictionary view shows for the current user information about levels, based on the `SA_COMPONENTS.CREATE_LEVEL` procedure.
- [ALL_SA_POLICIES](#)
The `ALL_SA_POLICIES` data dictionary view shows for the current user information about Oracle Label Security policies, based on the `SA_SYSDBA.CREATE_POLICY` procedure.
- [ALL_SA_PROG_PRIVS](#)
The `ALL_SA_PROG_PRIVS` data dictionary view shows for the current user information about the policy-specific privileges for program units, based on `SA_USER_ADMIN.SET_PROG_PRIVS`.
- [ALL_SA_SCHEMA_POLICIES](#)
The `ALL_SA_SCHEMA_POLICIES` data dictionary view shows for the current user information about policies applied to all tables in the schema, based on `SA_POLICY_ADMIN.APPLY_SCHEMA_POLICY`.
- [ALL_SA_TABLE_POLICIES](#)
The `ALL_SA_TABLE_POLICIES` data dictionary view shows for the current user information about a policy added to a database table, based on `SA_POLICY_ADMIN.APPLY_TABLE_POLICY` settings.
- [ALL_SA_USERS](#)
The `ALL_SA_USERS` data dictionary view shows for the current user information about Oracle Label Security user privileges, based on `SA_USER_ADMIN.SET_USER_LABELS` and `SA_USER_ADMIN.SET_USER_PRIVS`.
- [ALL_SA_USER_LABELS](#)
The `ALL_SA_USER_LABELS` data dictionary view shows for the current user label-specific information about users, based on the `SA_USER_ADMIN.SET_USER_LABELS` procedure settings.

- [ALL_SA_USER_LEVELS](#)
The `ALL_SA_USER_LEVELS` data dictionary view shows for the current user the minimum and maximum levels assigned to users, based on the `SA_USER_ADMIN.SET_LEVELS` procedure.
- [ALL_SA_USER_PRIVS](#)
The `ALL_SA_USER_PRIVS` data dictionary view shows for the current user policy-specific privileges granted to users, based on the `SA_USER_ADMIN.SET_USER_PRIVS` procedure.
- [CDB_OLS_STATUS](#)
The `CDB_OLS_STATUS` data dictionary view shows the configuration status of Oracle Label Security in the database in a multitenant environment.
- [DBA_SA_AUDIT_OPTIONS](#)
The `DBA_SA_AUDIT_OPTIONS` data dictionary view shows for the entire database the Oracle Label Security audit options.
- [DBA_SA_COMPARTMENTS](#)
The `ALL_SA_COMPARTMENTS` data dictionary view shows for the entire database information about Oracle Label Security policy compartments.
- [DBA_SA_DATA_LABELS](#)
The `ALL_SA_DATA_LABELS` data dictionary view shows for the entire database the labels and label tags for the specified Oracle Label Security policy.
- [DBA_SA_GROUPS](#)
The `ALL_SA_GROUPS` data dictionary view shows for the entire database information about Oracle Label Security policy groups.
- [DBA_SA_GROUP_HIERARCHY](#)
The `DBA_SA_GROUP_HIERARCHY` data dictionary view shows the hierarchy of groups (that is, parent-child relationships) in a policy.
- [DBA_SA_LABELS](#)
The `DBA_SA_LABELS` data dictionary view shows for the entire database information about the tags and types of labels for a policy.
- [DBA_SA_LEVELS](#)
The `DBA_SA_LEVELS` data dictionary view shows for the entire database information about levels associated with a policy.
- [DBA_SA_POLICIES](#)
The `DBA_SA_POLICIES` data dictionary view shows for the entire database information about Oracle Label Security policies, based on the `SA_SYSDBA.CREATE_POLICY` procedure.
- [DBA_SA_PROG_PRIVS](#)
The `DBA_SA_PROG_PRIVS` data dictionary view shows for the entire database information about the policy-specific privileges for program units.
- [DBA_SA_SCHEMA_POLICIES](#)
The `DBA_SA_SCHEMA_POLICIES` data dictionary view shows for the entire database information about policies that have been applied to all tables in the schema.
- [DBA_SA_TABLE_POLICIES](#)
The `DBA_SA_TABLE_POLICIES` data dictionary view shows for the entire database information about a policy that has been added to a database table.
- [DBA_SA_USERS](#)
The `DBA_SA_USERS` data dictionary view shows for the entire database information about the privileges that Oracle Label Security users have.

- [DBA_SA_USER_COMPARTMENTS](#)
The `DBA_SA_USER_COMPARTMENTS` data dictionary view shows for the entire database the user authorizations, based on the `SA_USER_ADMIN.ADD_COMPARTMENTS` procedure.
- [DBA_SA_USER_GROUPS](#)
The `DBA_SA_USER_GROUPS` data dictionary view shows for the entire database the groups associated with users, based on the `SA_USER_ADMIN.ADD_GROUPS` procedure.
- [DBA_SA_USER_LABELS](#)
The `DBA_SA_USER_LABELS` data dictionary view shows for the entire database label-specific information about users.
- [DBA_SA_USER_LEVELS](#)
The `DBA_SA_USER_LEVELS` data dictionary view shows for the entire database the minimum and maximum levels that have been assigned to users.
- [DBA_SA_USER_PRIVS](#)
The `DBA_SA_USER_PRIVS` data dictionary view shows for the current user the policy-specific privileges that have been granted to users.
- [DBA_OLS_STATUS](#)
The `DBA_OLS_STATUS` data dictionary view shows the configuration status of Oracle Label Security in the database.
- [USER_SA_SESSION](#)
The `USER_SA_SESSION` data dictionary view shows the security attribute values for the current database session.

ALL_SA_AUDIT_OPTIONS View

The `ALL_SA_AUDIT_OPTIONS` data dictionary view shows for the current user Oracle Label Security auditing options, based on the `SA_AUDIT_ADMIN.AUDIT` procedure settings.

See [SA_AUDIT_ADMIN.AUDIT](#).

This view displays whether auditing is configured to generate audit records per session (`BY SESSION`) or per access (`BY ACCESS`) and for successful or unsuccessful operations. Possible values are as follows:

- A dash (-) indicates that the audit option is not set.
- The `s` character indicates that the audit option is set `BY SESSION`.
- The `A` character indicates that the audit option is set `BY ACCESS`.
- Each audit option has two possible settings, `WHENEVER SUCCESSFUL` and `WHENEVER NOT SUCCESSFUL`, separated by a slash (/).

For example, in the following output, user `jjones` is audited with the `BY ACCESS` audit type for successful actions involving policy-specific privileges. User `rlayton` is audited with the `BY SESSION` audit type: audit records are written for failed attempts to remove policies and for successful attempts at setting user authorizations.

```
SELECT * FROM DBA_SA_AUDIT_OPTIONS;
```

| POLICY_NAME | USER_NAME | APY | REM | SET_ | PRV |
|-------------|-----------|-----|------|------|-----|
| ----- | ----- | --- | ---- | ---- | --- |
| HR_OLS_POL | JJONES | -/- | -/- | -/- | A/- |
| HR_OLS_POL | RLAYTON | -/- | -/S | S/- | -/- |

| Column | Datatype | Null | Description |
|-------------|---------------|----------|---|
| POLICY_NAME | VARCHAR2(30) | NOT NULL | Name of the Oracle Label Security policy |
| USER_NAME | VARCHAR2(128) | NOT NULL | Name of the user associated with the policy |
| APY | VARCHAR2(3) | NULL | Audit option; refers to the application of specified Oracle Label Security policies to tables and schemas |
| REM | VARCHAR2(3) | NULL | Audit option; refers to the removal of specified Oracle Label Security policies from tables and schemas |
| SET_ | VARCHAR2(3) | NULL | Audit option; refers to the setting of user authorizations, and user and program privileges |
| PRV | VARCHAR2(3) | NULL | Audit option; refers to the use of all policy-specific privileges |

ALL_SA_COMPARTMENTS

The `ALL_SA_COMPARTMENTS` data dictionary view shows information for the current user about Oracle Label Security policy compartments, based on the `SA_COMPONENTS.CREATE_COMPARTMENT` procedure settings.

| Column | Datatype | Null | Description |
|-------------|--------------|----------|---|
| POLICY_NAME | VARCHAR2(30) | NOT NULL | Name of the Oracle Label Security policy |
| COMP_NUM | NUMBER(4) | NOT NULL | Compartment number in the range of (0-9999) |
| SHORT_NAME | VARCHAR2(30) | NOT NULL | Short name for the compartment |
| LONG_NAME | VARCHAR2(80) | NOT NULL | Long name for the compartment |

Related Topics

- [SA_COMPONENTS.CREATE_COMPARTMENT](#)
The `SA_COMPONENTS.CREATE_COMPARTMENT` procedure creates a compartment and specify its short name and long name.

ALL_SA_DATA_LABELS

The `ALL_SA_DATA_LABELS` data dictionary view shows for the current user Oracle Label Security policy labels and tags, based on the `SA_LABEL_ADMIN.CREATE_LABEL` procedure settings.

| Column | Datatype | Null | Description |
|-------------|--------------|----------|--|
| POLICY_NAME | VARCHAR2(30) | NOT NULL | Name of the Oracle Label Security policy |

| Column | Datatype | Null | Description |
|-----------|----------------|------|---|
| LABEL | VARCHAR2(4000) | NULL | Short name of the level, compartment, or group that was specified as the label value |
| LABEL_TAG | NUMBER | NULL | Integer that represents the sort order of the label, relative to other policy labels (0-99999999) |

Related Topics

- [SA_LABEL_ADMIN.CREATE_LABEL](#)
The `SA_LABEL_ADMIN.CREATE_LABEL` procedure creates data labels.

ALL_SA_GROUPS

The `ALL_SA_GROUPS` data dictionary shows information about the current user's Oracle Label Security policy groups, based on the `SA_COMPONENTS.CREATE_GROUP` and `SA_COMPONENTS.ALTER_GROUP_PARENT` procedures.

| Column | Datatype | Null | Description |
|-------------|--------------|----------|--|
| POLICY_NAME | VARCHAR2(30) | NOT NULL | Name of the Oracle Label Security policy |
| GROUP_NUM | NUMBER(4) | NOT NULL | Group number (0-9999) |
| SHORT_NAME | VARCHAR2(30) | NOT NULL | Short name of the group |
| LONG_NAME | VARCHAR2(80) | NOT NULL | Long name of the group |
| PARENT_NUM | NUMBER(4) | NULL | Numerical ID for the associated parent group |
| PARENT_NAME | VARCHAR2(30) | NULL | Name of the group assigned as the parent for the group |

Related Topics

- [SA_COMPONENTS.CREATE_GROUP](#)
The `SA_COMPONENTS.CREATE_GROUP` procedure creates a group and specify its short name and long name, and optionally a parent group.
- [SA_COMPONENTS.ALTER_GROUP_PARENT](#)
The `SA_COMPONENTS.ALTER_GROUP_PARENT` procedure changes the parent group associated with a particular group.

ALL_SA_LABELS

The `ALL_SA_LABELS` data dictionary view shows for the current user information about the tags and types of labels, based on `SA_LABEL_ADMIN.CREATE_LABEL` and `SA_LABEL_ADMIN.ALTER_LABEL`.

Access to `ALL_SA_LABELS` is `PUBLIC`. However, only the labels authorized for read access by the session are visible.

| Column | Datatype | Null | Description |
|-------------|----------------|----------|--|
| POLICY_NAME | VARCHAR2(30) | NOT NULL | Name of the Oracle Label Security policy |
| LABEL | VARCHAR2(4000) | NOT NULL | Short name of the level associated with this label |
| LABEL_TAG | NUMBER(30) | NOT NULL | Integer tag assigned to the label |
| LABEL_TYPE | VARCHAR2(15) | NULL | Type of label |

Related Topics

- [SA_LABEL_ADMIN.CREATE_LABEL](#)
The `SA_LABEL_ADMIN.CREATE_LABEL` procedure creates data labels.
- [SA_LABEL_ADMIN.ALTER_LABEL](#)
The `SA_LABEL_ADMIN.ALTER_LABEL` procedure changes the character string label definition associated with a label tag.

ALL_SA_LEVELS

The `ALL_SA_LEVELS` data dictionary view shows for the current user information about levels, based on the `SA_COMPONENTS.CREATE_LEVEL` procedure.

| Column | Datatype | Null | Description |
|-------------|--------------|----------|--|
| POLICY_NAME | VARCHAR2(30) | NOT NULL | Name of the Oracle Label Security policy |
| LEVEL_NUM | NUMBER(4) | NOT NULL | Level number (0-9999) |
| SHORT_NAME | VARCHAR2(30) | NOT NULL | Short name for the level |
| LONG_NAME | VARCHAR2(80) | NOT NULL | Long name for the level |

Related Topics

- [SA_COMPONENTS.CREATE_LEVEL](#)
The `SA_COMPONENTS.CREATE_LEVEL` procedure creates a level and specify its short name and long name.

ALL_SA_POLICIES

The `ALL_SA_POLICIES` data dictionary view shows for the current user information about Oracle Label Security policies, based on the `SA_SYSDBA.CREATE_POLICY` procedure.

| Column | Datatype | Null | Description |
|-------------|---------------|----------|---|
| POLICY_NAME | VARCHAR2(30) | NOT NULL | Name of the Oracle Label Security policy |
| COLUMN_NAME | VARCHAR2(128) | NOT NULL | Name of the column that was added to tables protected by the policy |
| STATUS | VARCHAR2(8) | NULL | Whether the policy has been enabled or disabled |

| Column | Datatype | Null | Description |
|----------------|----------------|------|--|
| POLICY_OPTIONS | VARCHAR2(4000) | NULL | Options that were set for this policy See Categories of Policy Enforcement Options for a listing of the possible enforcement options. |

Related Topics

- [SA_SYSDBA.CREATE_POLICY](#)
The `SA_SYSDBA.CREATE_POLICY` procedure creates a new Oracle Label Security policy, defines a policy-specific column name, and specifies default policy options.

ALL_SA_PROG_PRIVS

The `ALL_SA_PROG_PRIVS` data dictionary view shows for the current user information about the policy-specific privileges for program units, based on `SA_USER_ADMIN.SET_PROG_PRIVS`.

| Column | Datatype | Null | Description |
|--------------------|----------------|----------|---|
| SCHEMA_NAME | VARCHAR2(128) | NOT NULL | Name of the schema that contains the program unit |
| PROGRAM_NAME | VARCHAR(128) | NOT NULL | Program unit that was granted privileges |
| POLICY_NAME | VARCHAR2(30) | NOT NULL | Name of the Oracle Label Security policy |
| PROGRAM_PRIVILEGES | VARCHAR2(4000) | NULL | Policy-specific privileges. See About Granting Privileges to Users and Trusted Program Units for the Policy for list of possible privileges. |

Related Topics

- [SA_USER_ADMIN.SET_PROG_PRIVS](#)
The `SA_USER_ADMIN.SET_PROG_PRIVS` procedure sets policy-specific privileges for program units.

ALL_SA_SCHEMA_POLICIES

The `ALL_SA_SCHEMA_POLICIES` data dictionary view shows for the current user information about policies applied to all tables in the schema, based on `SA_POLICY_ADMIN.APPLY_SCHEMA_POLICY`.

| Column | Datatype | Null | Description |
|-------------|---------------|----------|--|
| POLICY_NAME | VARCHAR2(30) | NOT NULL | Name of the Oracle Label Security policy |
| SCHEMA_NAME | VARCHAR2(128) | NOT NULL | Name of the schema associated with this policy |

| Column | Datatype | Null | Description |
|----------------|----------------|------|--|
| STATUS | VARCHAR2(8) | NULL | Whether the policy has been enabled or disabled for the schema (by the SA_POLICY_ADMIN.APPLY_SCHEMA_POLICY or SA_POLICY_ADMIN.DISABLE_SCHEMA_POLICY for procedure) |
| SCHEMA_OPTIONS | VARCHAR2(4000) | NULL | Options that have been applied. |

Related Topics

- [SA_POLICY_ADMIN.APPLY_SCHEMA_POLICY](#)
The SA_POLICY_ADMIN.APPLY_SCHEMA_POLICY procedure applies a policy to all of the tables in a schema and enables the policy for these tables.
- [Categories of Policy Enforcement Options](#)
Oracle Label Security enforces policies using three categories: label management options, access control options, and overriding options.

ALL_SA_TABLE_POLICIES

The ALL_SA_TABLE_POLICIES data dictionary view shows for the current user information about a policy added to a database table, based SA_POLICY_ADMIN.APPLY_TABLE_POLICY settings.

| Column | Datatype | Null | Description |
|---------------|----------------|----------|---|
| POLICY_NAME | VARCHAR2(30) | NOT NULL | Name of the Oracle Label Security policy |
| SCHEMA_NAME | VARCHAR2(128) | NOT NULL | Schema that contains the table that the policy protects |
| TABLE_NAME | VARCHAR2(128) | NOT NULL | Table to be protected by the policy |
| STATUS | VARCHAR2(8) | NULL | Whether the policy has been enabled or disabled for the table (by the SA_POLICY_ADMIN.APPLY_TABLE_POLICY or SA_POLICY_ADMIN.DISABLE_TABLE_POLICY for procedure) |
| TABLE_OPTIONS | VARCHAR2(4000) | NULL | Policy enforcement options to be used for the table |
| FUNCTION | VARCHAR2(1024) | NULL | Name of the function to return a label value to use as the default |
| PREDICATE | VARCHAR2(256) | NULL | Predicate to combine (using AND or OR) with the label-based predicate for READ_CONTROL |

Related Topics

- [SA_POLICY_ADMIN.APPLY_TABLE_POLICY](#)
The SA_POLICY_ADMIN.APPLY_TABLE_POLICY procedure adds the specified policy to a table.

- [Categories of Policy Enforcement Options](#)
Oracle Label Security enforces policies using three categories: label management options, access control options, and overriding options.

ALL_SA_USERS

The ALL_SA_USERS data dictionary view shows for the current user information about Oracle Label Security user privileges, based on SA_USER_ADMIN.SET_USER_LABELS and SA_USER_ADMIN.SET_USER_PRIVS.

| Column | Type | Null | Description |
|---------------------|----------------|----------|--|
| USER_NAME | VARCHAR2(1024) | NOT NULL | Name of the user |
| POLICY_NAME | VARCHAR2(30) | NOT NULL | Name of the Oracle Label Security policy |
| USER_PRIVILEGES | VARCHAR2(4000) | NULL | Policy-specific privileges granted to the user. |
| MAX_READ_LABEL | VARCHAR2(4000) | NULL | Label string to initialize the user's maximum authorized read label |
| MAX_WRITE_LABEL | VARCHAR2(4000) | NULL | Label string to initialize the user's maximum authorized write label |
| MIN_WRITE_LABEL | VARCHAR2(4000) | NULL | Label string to initialize the user's minimum authorized write label |
| DEFAULT_READ_LABEL | VARCHAR2(4000) | NULL | Label string to initialize the user's session label, including level, compartments, and groups, for read access |
| DEFAULT_WRITE_LABEL | VARCHAR2(4000) | NULL | Label string to initialize the user's session label, including level, compartments, and groups, for write access |
| DEFAULT_ROW_LABEL | VARCHAR2(4000) | NULL | Label string to initialize the program's row label; includes level, components, and groups |
| USER_LABELS | VARCHAR2(4000) | NULL | Retained solely for backward compatibility and will be removed in the next release. The USER_LABELS column is deprecated starting with Oracle Database 18c because it is redundant. The information in this column is displayed in other ALL_SA_USERS and DBA_SA_USERS columns. |

Related Topics

- [SA_USER_ADMIN.SET_USER_LABELS](#)
The SA_USER_ADMIN.SET_USER_LABELS procedure sets the user's levels, compartments, and groups using a set of labels, instead of the individual components.
- [SA_USER_ADMIN.SET_USER_PRIVS](#)
The SA_USER_ADMIN.SET_USER_PRIVS procedure sets policy-specific privileges for users.

- [About Granting Privileges to Users and Trusted Program Units for the Policy](#)
After you have authorized users for policy levels, compartments, and groups, you are ready to grant the user privileges.

ALL_SA_USER_LABELS

The ALL_SA_USER_LABELS data dictionary view shows for the current user label-specific information about users, based on the SA_USER_ADMIN.SET_USER_LABELS procedure settings.

| Column | Datatype | Null | Description |
|---------------------|----------------|----------|--|
| USER_NAME | VARCHAR2(1024) | NOT NULL | Name of the user |
| POLICY_NAME | VARCHAR2(30) | NOT NULL | Name of the Oracle Label Security policy |
| LABELS | VARCHAR2(4000) | NULL | Retained solely for backward compatibility and will be removed in the next release. The LABELS column is deprecated starting with Oracle Database 12c release (12.2.0.2) because it is redundant. The information in this column is displayed in ALL_SA_USER_LABELS and DBA_SA_USER_LABELS columns. |
| MAX_READ_LABEL | VARCHAR2(4000) | NOT NULL | Label string to initialize the user's maximum authorized read label |
| MAX_WRITE_LABEL | VARCHAR2(4000) | NULL | Label string to initialize the user's maximum authorized write label |
| MIN_WRITE_LABEL | VARCHAR2(4000) | NULL | Label string to initialize the user's minimum authorized write label |
| DEFAULT_READ_LABEL | VARCHAR2(4000) | NULL | Label string to initialize the user's session label, including level, compartments, and groups, for read access |
| DEFAULT_WRITE_LABEL | VARCHAR2(4000) | NULL | Label string to initialize the user's session label, including level, compartments, and groups, for write access |
| DEFAULT_ROW_LABEL | VARCHAR2(4000) | NULL | Label string to initialize the program's row label; includes level, components, and groups |

Related Topics

- [SA_USER_ADMIN.SET_USER_LABELS](#)
The SA_USER_ADMIN.SET_USER_LABELS procedure sets the user's levels, compartments, and groups using a set of labels, instead of the individual components.

ALL_SA_USER_LEVELS

The `ALL_SA_USER_LEVELS` data dictionary view shows for the current user the minimum and maximum levels assigned to users, based on the `SA_USER_ADMIN.SET_LEVELS` procedure.

It also lists the user's session label and row label default values.

| Column | Datatype | Null | Description |
|--------------------------|-----------------------------|----------|---|
| <code>POLICY_NAME</code> | <code>VARCHAR2(30)</code> | NOT NULL | Name of the Oracle Label Security policy |
| <code>USER_NAME</code> | <code>VARCHAR2(1024)</code> | NOT NULL | Name of the user |
| <code>MAX_LEVEL</code> | <code>VARCHAR2(30)</code> | NOT NULL | Short name of the highest level for read and write access |
| <code>MIN_LEVEL</code> | <code>VARCHAR2(30)</code> | NOT NULL | Short name of the lowest level for read and write access |
| <code>DEF_LEVEL</code> | <code>VARCHAR2(30)</code> | NOT NULL | Short name of the default level |
| <code>ROW_LEVEL</code> | <code>VARCHAR2(30)</code> | NOT NULL | Short name of the row level |

Related Topics

- [SA_USER_ADMIN.SET_LEVELS](#)
The `SA_USER_ADMIN.SET_LEVELS` procedure assigns a user minimum and maximum levels and identifies default values for the user's session label and row label.

ALL_SA_USER_PRIVS

The `ALL_SA_USER_PRIVS` data dictionary view shows for the current user policy-specific privileges granted to users, based on the `SA_USER_ADMIN.SET_USER_PRIVS` procedure.

| Column | Datatype | Null | Description |
|------------------------------|-----------------------------|----------|--|
| <code>USER_NAME</code> | <code>VARCHAR2(1024)</code> | NOT NULL | Name of the user |
| <code>POLICY_NAME</code> | <code>VARCHAR2(30)</code> | NOT NULL | Name of the Oracle Label Security policy |
| <code>USER_PRIVILEGES</code> | <code>VARCHAR2(4000)</code> | NULL | Policy-specific privileges granted to the user |

Related Topics

- [SA_USER_ADMIN.SET_USER_PRIVS](#)
The `SA_USER_ADMIN.SET_USER_PRIVS` procedure sets policy-specific privileges for users.
- [About Granting Privileges to Users and Trusted Program Units for the Policy](#)
After you have authorized users for policy levels, compartments, and groups, you are ready to grant the user privileges.

CDB_OLS_STATUS

The `CDB_OLS_STATUS` data dictionary view shows the configuration status of Oracle Label Security in the database in a multitenant environment.

| Column | Datatype | Null | Description |
|-------------|----------------|----------|---|
| NAME | VARCHAR2(20) | NOT NULL | Name of the status. Values are: <ul style="list-style-type: none"> OLS_CONFIGURE_STATUS OLS_DIRECTORY_STATUS OLS_ENABLE_STATUS |
| STATUS | VARCHAR2(5) | NOT NULL | Indicates the status of the feature mentioned in the corresponding name column. For example, a TRUE value for the OLS_CONFIGURE_STATUS status says that Oracle Label Security has been configured. |
| DESCRIPTION | VARCHAR2(4000) | NOT NULL | Description of the status: <ul style="list-style-type: none"> OLS_CONFIGURE_STATUS: Determines if Oracle Label Security is configured. OLS_DIRECTORY_STATUS: Determines if Oracle Internet Directory is enabled with Oracle Label Security. OLS_ENABLE_STATUS: Determines if Oracle Label Security is enabled. |
| CON_ID | NUMBER | NOT NULL | The container database ID number |

DBA_SA_AUDIT_OPTIONS

The `DBA_SA_AUDIT_OPTIONS` data dictionary view shows for the entire database the Oracle Label Security audit options.

Its columns are the same as `ALL_SA_AUDIT_OPTIONS`.

Related Topics

- [ALL_SA_AUDIT_OPTIONS View](#)
The `ALL_SA_AUDIT_OPTIONS` data dictionary view shows for the current user Oracle Label Security auditing options, based on the `SA_AUDIT_ADMIN.AUDIT` procedure settings.

DBA_SA_COMPARTMENTS

The `ALL_SA_COMPARTMENTS` data dictionary view shows for the entire database information about Oracle Label Security policy compartments.

Its columns are the same as `ALL_SA_COMPARTMENTS`.

Related Topics

- [ALL_SA_COMPARTMENTS](#)
The `ALL_SA_COMPARTMENTS` data dictionary view shows information for the current user about Oracle Label Security policy compartments, based on the `SA_COMPONENTS.CREATE_COMPARTMENT` procedure settings.

DBA_SA_DATA_LABELS

The `ALL_SA_DATA_LABELS` data dictionary view shows for the entire database the labels and label tags for the specified Oracle Label Security policy.

Its columns are the same as `ALL_SA_DATA_LABELS`.

Related Topics

- [ALL_SA_DATA_LABELS](#)
The `ALL_SA_DATA_LABELS` data dictionary view shows for the current user Oracle Label Security policy labels and tags, based on the `SA_LABEL_ADMIN.CREATE_LABEL` procedure settings.

DBA_SA_GROUPS

The `ALL_SA_GROUPS` data dictionary view shows for the entire database information about Oracle Label Security policy groups.

Its columns are the same as `ALL_SA_GROUPS`.

Related Topics

- [ALL_SA_GROUPS](#)
The `ALL_SA_GROUPS` data dictionary shows information about the current user's Oracle Label Security policy groups, based on the `SA_COMPONENTS.CREATE_GROUP` and `SA_COMPONENTS.ALTER_GROUP_PARENT` procedures.

DBA_SA_GROUP_HIERARCHY

The `DBA_SA_GROUP_HIERARCHY` data dictionary view shows the hierarchy of groups (that is, parent-child relationships) in a policy.

| Column | Type | Null | Description |
|------------------------------|-----------------------------|----------|--|
| <code>POLICY_NAME</code> | <code>VARCHAR2(30)</code> | NOT NULL | Name of the Oracle Label Security policy |
| <code>HIERARCHY_LEVEL</code> | <code>NUMBER</code> | NULL | Indicates the level of a particular group in a group hierarchy. A group with no parent group will have <code>HIERARCHY_LEVEL 1</code> . Its child group will have <code>HIERARCHY_LEVEL 2</code> and so on. For example, consider these groups in the following order: <ol style="list-style-type: none"> 1. G1, G4 2. G2, G5 3. G3 Here, G1 and G4 have <code>HIERARCHY_LEVEL 1</code> ; G2 and G5 have <code>HIERARCHY_LEVEL 2</code> , and G3 has <code>HIERARCHY_LEVEL 3</code> . The parent-child relationships are: <ul style="list-style-type: none"> • G3 is the child group of G2, and G2 is the child group of G1. • G5 is the child group of G4. |
| <code>GROUP_NAME</code> | <code>VARCHAR2(4000)</code> | NULL | Short name of the group intended to indicate the hierarchy level |

DBA_SA_LABELS

The `DBA_SA_LABELS` data dictionary view shows for the entire database information about the tags and types of labels for a policy.

Its columns are the same as `ALL_SA_LABELS`.

Related Topics

- [ALL_SA_LABELS](#)
The `ALL_SA_LABELS` data dictionary view shows for the current user information about the tags and types of labels, based on `SA_LABEL_ADMIN.CREATE_LABEL` and `SA_LABEL_ADMIN.ALTER_LABEL`.

DBA_SA_LEVELS

The `DBA_SA_LEVELS` data dictionary view shows for the entire database information about levels associated with a policy.

Its columns are the same as `ALL_SA_LEVELS`.

Related Topics

- [ALL_SA_LABELS](#)
The `ALL_SA_LABELS` data dictionary view shows for the current user information about the tags and types of labels, based on `SA_LABEL_ADMIN.CREATE_LABEL` and `SA_LABEL_ADMIN.ALTER_LABEL`.

DBA_SA_POLICIES

The `DBA_SA_POLICIES` data dictionary view shows for the entire database information about Oracle Label Security policies, based on the `SA_SYSDBA.CREATE_POLICY` procedure.

This view also shows whether the policy has been enabled or disabled and its subscription status.

| Column | Datatype | Null | Description |
|-------------------------------|-----------------------------|----------|---|
| <code>POLICY_NAME</code> | <code>VARCHAR2(30)</code> | NOT NULL | Name of the Oracle Label Security policy |
| <code>COLUMN_NAME</code> | <code>VARCHAR2(128)</code> | NOT NULL | Name of the column that was added to tables protected by the policy |
| <code>STATUS</code> | <code>VARCHAR2(8)</code> | NULL | Whether the policy has been enabled or disabled |
| <code>POLICY_OPTIONS</code> | <code>VARCHAR2(4000)</code> | NULL | Options that were set for this policy. See Categories of Policy Enforcement Options for a listing of the possible enforcement options. |
| <code>POLICY_SUBSCRIBE</code> | <code>VARCHAR2(5)</code> | NULL | Indicates the policy's subscription status, based on the <code>SA_POLICY_ADMIN.POLICY_SUBSCRIBE</code> or <code>SA_POLICY_ADMIN.POLICY_UNSUBSCRIBE</code> procedure |

DBA_SA_PROG_PRIVS

The `DBA_SA_PROG_PRIVS` data dictionary view shows for the entire database information about the policy-specific privileges for program units.

Its columns are the same as `ALL_SA_PROG_PRIVS`.

Related Topics

- [ALL_SA_PROG_PRIVS](#)
The `ALL_SA_PROG_PRIVS` data dictionary view shows for the current user information about the policy-specific privileges for program units, based on `SA_USER_ADMIN.SET_PROG_PRIVS`.

DBA_SA_SCHEMA_POLICIES

The `DBA_SA_SCHEMA_POLICIES` data dictionary view shows for the entire database information about policies that have been applied to all tables in the schema.

Its columns are the same as `ALL_SA_SCHEMA_POLICIES`.

Related Topics

- [ALL_SA_SCHEMA_POLICIES](#)
The `ALL_SA_SCHEMA_POLICIES` data dictionary view shows for the current user information about policies applied to all tables in the schema, based on `SA_POLICY_ADMIN.APPLY_SCHEMA_POLICY`.

DBA_SA_TABLE_POLICIES

The `DBA_SA_TABLE_POLICIES` data dictionary view shows for the entire database information about a policy that has been added to a database table.

Its columns are the same as `ALL_SA_TABLE_POLICIES`.

Related Topics

- [ALL_SA_SCHEMA_POLICIES](#)
The `ALL_SA_SCHEMA_POLICIES` data dictionary view shows for the current user information about policies applied to all tables in the schema, based on `SA_POLICY_ADMIN.APPLY_SCHEMA_POLICY`.

DBA_SA_USERS

The `DBA_SA_USERS` data dictionary view shows for the entire database information about the privileges that Oracle Label Security users have.

Its columns are the same as `ALL_SA_USERS`.

Related Topics

- [ALL_SA_USERS](#)
The `ALL_SA_USERS` data dictionary view shows for the current user information about Oracle Label Security user privileges, based on `SA_USER_ADMIN.SET_USER_LABELS` and `SA_USER_ADMIN.SET_USER_PRIVS`.

DBA_SA_USER_COMPARTMENTS

The `DBA_SA_USER_COMPARTMENTS` data dictionary view shows for the entire database the user authorizations, based on the `SA_USER_ADMIN.ADD_COMPARTMENTS` procedure.

This view also indicates whether the compartments are authorized for write and read privileges

| Column | Datatype | Null | Description |
|--------------------------|-----------------------------|----------|--|
| <code>POLICY_NAME</code> | <code>VARCHAR2(30)</code> | NOT NULL | Name of the Oracle Label Security policy |
| <code>USER_NAME</code> | <code>VARCHAR2(1024)</code> | NOT NULL | Name of the user |
| <code>COMP</code> | <code>VARCHAR2(30)</code> | NOT NULL | Short name of compartments that were added |
| <code>RW_ACCESS</code> | <code>VARCHAR2(5)</code> | NULL | Access mode. Possible values are: <ul style="list-style-type: none"> <code>SA_UTL.READ_ONLY</code> indicates no write access <code>SA_UTL.READ_WRITE</code> indicates that write is authorized |
| <code>DEF_COMP</code> | <code>VARCHAR2(1)</code> | NOT NULL | Whether the compartments are in the default compartments |
| <code>ROW_COMP</code> | <code>VARCHAR2(1)</code> | NOT NULL | whether the compartments are in the row label |

Related Topics

- [SA_USER_ADMIN.ADD_COMPARTMENTS](#)

The `SA_USER_ADMIN.ADD_COMPARTMENTS` procedure adds (assigns) compartments to a user's authorizations, indicating if the compartments are authorized for write and read privileges.

DBA_SA_USER_GROUPS

The `DBA_SA_USER_GROUPS` data dictionary view shows for the entire database the groups associated with users, based on the `SA_USER_ADMIN.ADD_GROUPS` procedure.

| Column | Datatype | Null | Description |
|--------------------------|-----------------------------|----------|--|
| <code>POLICY_NAME</code> | <code>VARCHAR2(30)</code> | NOT NULL | Name of the Oracle Label Security policy |
| <code>USER_NAME</code> | <code>VARCHAR2(1024)</code> | NOT NULL | Name of the user |
| <code>GRP</code> | <code>VARCHAR2(30)</code> | NOT NULL | Short name of groups that were added |
| <code>RW_ACCESS</code> | <code>VARCHAR2(5)</code> | NULL | Access mode. Possible values are: <ul style="list-style-type: none"> <code>SA_UTL.READ_ONLY</code> indicates read-only access <code>SA_UTL.READ_WRITE</code> indicates read and write access |
| <code>DEF_GROUP</code> | <code>VARCHAR2(1)</code> | NOT NULL | Whether the group is in a default group |
| <code>ROW_GROUP</code> | <code>VARCHAR2(1)</code> | NOT NULL | Whether the group is in a label |

Related Topics

- [SA_USER_ADMIN.ADD_GROUPS](#)
The `SA_USER_ADMIN.ADD_GROUPS` procedure adds (assigns) groups to a user, indicating if the groups are authorized for write and read privileges.

DBA_SA_USER_LABELS

The `DBA_SA_USER_LABELS` data dictionary view shows for the entire database label-specific information about users.

Its columns are the same as `ALL_SA_USER_LABELS`.

Related Topics

- [ALL_SA_USER_LABELS](#)
The `ALL_SA_USER_LABELS` data dictionary view shows for the current user label-specific information about users, based on the `SA_USER_ADMIN.SET_USER_LABELS` procedure settings.

DBA_SA_USER_LEVELS

The `DBA_SA_USER_LEVELS` data dictionary view shows for the entire database the minimum and maximum levels that have been assigned to users.

This view also shows the default values for the user's session label and row label.

Its columns are the same as `ALL_SA_USER_LEVELS`.

Related Topics

- [ALL_SA_USER_LEVELS](#)
The `ALL_SA_USER_LEVELS` data dictionary view shows for the current user the minimum and maximum levels assigned to users, based on the `SA_USER_ADMIN.SET_LEVELS` procedure.

DBA_SA_USER_PRIVS

The `DBA_SA_USER_PRIVS` data dictionary view shows for the current user the policy-specific privileges that have been granted to users.

Its columns are the same as `ALL_SA_USER_PRIVS`.

Related Topics

- [ALL_SA_USER_PRIVS](#)
The `ALL_SA_USER_PRIVS` data dictionary view shows for the current user policy-specific privileges granted to users, based on the `SA_USER_ADMIN.SET_USER_PRIVS` procedure.

DBA_OLS_STATUS

The `DBA_OLS_STATUS` data dictionary view shows the configuration status of Oracle Label Security in the database.

| Column | Datatype | Null | Description |
|-------------|----------------|------|---|
| NAME | VARCHAR2(20) | NULL | Name of the status. Values are: <ul style="list-style-type: none"> OLS_CONFIGURE_STATUS OLS_DIRECTORY_STATUS OLS_ENABLE_STATUS |
| STATUS | VARCHAR2(5) | NULL | Indicates the status of the feature mentioned in the corresponding name column. For example, a TRUE value for the OLS_CONFIGURE_STATUS status says that Oracle Label Security has been configured. |
| DESCRIPTION | VARCHAR2(4000) | NULL | Description of the status: <ul style="list-style-type: none"> OLS_CONFIGURE_STATUS: Determines if Oracle Label Security is configured. OLS_DIRECTORY_STATUS: Determines if Oracle Internet Directory is enabled with Oracle Label Security. OLS_ENABLE_STATUS: Determines if Oracle Label Security is enabled. |

USER_SA_SESSION

The `USER_SA_SESSION` data dictionary view shows the security attribute values for the current database session.

Access to this view is PUBLIC.

| Column | Datatype | Null | Description |
|-----------------|----------------|----------|---|
| POLICY_NAME | VARCHAR2(30) | NOT NULL | Name of the Oracle Label Security policy |
| SA_USER_NAME | VARCHAR2(4000) | NULL | Name of the current session user |
| PRIVS | VARCHAR2(4000) | NULL | Current session privileges |
| MAX_READ_LABEL | VARCHAR2(4000) | NULL | Label string that initialized the user's maximum authorized read label |
| MAX_WRITE_LABEL | VARCHAR2(4000) | NULL | Label string that initialized the user's maximum authorized write label |
| MIN_LEVEL | VARCHAR2(4000) | NULL | Minimum Oracle Label Security level authorized for the session |
| LABEL | VARCHAR2(4000) | NULL | Label for the current database session |
| COMP_WRITE | VARCHAR2(4000) | NULL | Compartments to which the user is authorized to write |
| GROUP_WRITE | VARCHAR2(4000) | NULL | Groups to which the user is authorized to write |
| ROW_LABEL | VARCHAR2(4000) | NULL | Row label that is associated with the policy for the current session |

Oracle Label Security User-Created Auditing View

The `SA_AUDIT_ADMIN.CREATE_VIEW` procedure can be used to create an audit trail view for a specific policy.

By default, this view is named `DBA_policyname_AUDIT_TRAIL`.

| Column | Datatype | Null | Description |
|--------------------|-----------------------------|----------|--|
| USERNAME | VARCHAR2(128) | NULL | Name of the user whose actions were audited |
| USERHOST | VARCHAR2(128) | NULL | Client host machine name |
| TERMINAL | VARCHAR2(255) | NULL | Identifier of the user's terminal |
| TIMESTAMP | DATE | NULL | Date and time of the creation of the audit trail entry (date and time of user login for entries created by <code>AUDIT SESSION</code>) in the local database session time zone |
| OWNER | VARCHAR2(128) | NULL | Creator of the object affected by the action |
| OBJ_NAME | VARCHAR2(128) | NULL | Name of the object affected by the action |
| ACTION | NUMBER | NOT NULL | Numeric action type code. The corresponding name of the action type is in the <code>ACTION_NAME</code> column. |
| ACTION_NAME | VARCHAR2(47) | NULL | Name of the action type corresponding to the numeric code in the <code>ACTION</code> column |
| COMMENT_TEXT | VARCHAR2(4000) | NULL | Text comment on the audit trail entry, providing more information about the statement audited Also indicates how the user was authenticated. The method can be one of the following: <ul style="list-style-type: none"> • <code>DATABASE</code>: Authentication was done by password • <code>NETWORK</code>: Authentication was done by Oracle Net Services or by strong authentication |
| SESSIONID | NUMBER | NOT NULL | Numeric ID for each Oracle session |
| ENTRYID | NUMBER | NOT NULL | Numeric ID for each audit trail entry in the session |
| STATEMENTID | NUMBER | NOT NULL | Numeric ID for each statement run |
| RETURNCODE | NUMBER | NOT NULL | Oracle error code generated by the action. Some useful values: <ul style="list-style-type: none"> • 0: Action succeeded • 2004: Security violation |
| EXTENDED_TIMESTAMP | TIMESTAMP(6) WITH TIME ZONE | NULL | Timestamp of the creation of the audit trail entry (timestamp of user login for entries created by <code>AUDIT SESSION</code>) in UTC (Coordinated Universal Time) time zone |
| OLS_COL | VARCHAR2(4000) | NULL | Name of the column that was added to the tables that Oracle Label Security protects |

Related Topics

- [SA_AUDIT_ADMIN.CREATE_VIEW](#)
The `SA_AUDIT_ADMIN.CREATE_VIEW` procedure creates an audit trail view named `DBA_policyname_AUDIT_TRAIL`.

Restrictions in Oracle Label Security

Several restrictions exist in this Oracle Label Security release.

These restrictions are as follows:

- `CREATE TABLE AS SELECT` restriction

If you attempt to perform `CREATE TABLE AS SELECT` in a schema that is protected by an Oracle Label Security policy, then the statement will fail.

- Label tag restriction

Label tags must be unique across the policies in the database. When you use multiple policies in a database, you cannot use the same numeric label tag in different policies.

- Export restriction

Before Oracle Database 12c release 1 (12.1), the `LBACSYS` schema could not be exported due to the use of opaque types in Oracle Label Security. An export of the entire database (parameter `FULL=Y`) with Oracle Label Security installed can be done, except that the `LBACSYS` schema would not be exported.

From Oracle Database release 12c on, this restriction has been removed. See [Full Database Export](#) for additional details on the database versions that the export can be supported from.

- Oracle Label Security removal restriction

You cannot remove Oracle Label Security, but you can disable it. See [Disabling Oracle Label Security](#).

- Shared schema support restriction

User accounts defined in the Oracle Internet Directory cannot be given individual Oracle Label Security authorizations. However, authorizations can be given to the shared schema to which the directory users are mapped.

The Oracle Label Security function `SET_ACCESS_PROFILE` can be used programmatically to set the label authorization profile to use after a user has been authenticated and mapped to a shared schema. Oracle Label Security does not enforce a mapping between users who are given label authorizations in Oracle Label Security and actual database users.

- Hidden columns restriction

PL/SQL does not recognize references to hidden columns in tables. A compiler error will be generated.

G

Frequently Asked Questions about Oracle Label Security

Customers have frequently asked questions about Oracle Label Security.

- [Who Uses Oracle Label Security?](#)
Sensitivity labels can categorize data in virtually every industry.
- [How Can Oracle Label Security Address My Security Needs?](#)
Oracle Label Security can label data and restrict access with a high degree of granularity.
- [Should I Use Oracle Label Security to Protect All My Tables?](#)
No, you should not use Oracle Label Security to protect all of your tables.
- [What Is the Difference Between Oracle Virtual Private Database and Oracle Label Security?](#)
Oracle Virtual Private Database (VPD) is provided at no additional cost with the Enterprise Edition of Oracle Database.
- [Can I Combine Oracle Virtual Private Database and Oracle Label Security?](#)
Yes. You can use a `WHERE` clause or a VPD policy.
- [Can I Use Oracle Label Security with Oracle E-Business Suite?](#)
Oracle Applications use Oracle Virtual Private Database (VPD) to provide new functionality and security protections.
- [Can I Use Oracle Label Security with Oracle Database Vault?](#)
You can protect Oracle Database Vault tables using Oracle Label Security just as you would do for an Oracle Database table.
- [Does Oracle Label Security Provide Column-Level Access Control?](#)
No, Oracle Label Security is not column aware.
- [Can I Base Secure Application Roles on Oracle Label Security?](#)
Yes, you can base secure application roles on Oracle Label Security.
- [What Are Trusted Stored Program Units?](#)
Trusted stored program units are stored procedures, functions, and packages that execute with the system and object privileges (DAC) of the definer.
- [Does VPD or OLS Add an Additional Column to the Protected Table?](#)
When you apply an Oracle Label Security (OLS) policy to a table, the policy adds an additional column to the table.
- [Why Should the Additional OLS Row Label Column Be Hidden?](#)
Most applications are designed with access control mechanisms in mind, so Oracle Label Security must do this transparently.

Who Uses Oracle Label Security?

Sensitivity labels can categorize data in virtually every industry.

These industries include health care, law enforcement, energy, retail, national security, and defense industries.

The following list gives some examples of sensitivity labels:

- Internal
- ConfidentialPhysician OnlyHighly SensitiveWidget CorporationConfidential:
Chicago OperationSensitive: Finance : EuropeTop SecretUnclassified

How Can Oracle Label Security Address My Security Needs?

Oracle Label Security can label data and restrict access with a high degree of granularity.

This is especially useful when multiple organizations or companies share a single application. Sensitivity labels can be used to restrict application users to an organization or to a subset of data within an organization.

Data privacy is important to consumers and regulatory measures continue to be announced. Oracle Label Security can be used to implement privacy policies on data, restricting access to only those who have a need-to-know.

Should I Use Oracle Label Security to Protect All My Tables?

No, you should not use Oracle Label Security to protect all of your tables.

The traditional Oracle discretionary access control (DAC) object privileges such as `SELECT`, `INSERT`, `UPDATE`, and `DELETE` combined with database roles and stored procedures are sufficient in most cases. You can find a user's privileges by querying the `DBA_SYS_PRIVS` data dictionary view.

In addition, there are many other ways that you can protect access to your database tables, such as using Oracle Virtual Private Database (VPD), Oracle Database Vault, Oracle Data Redaction, Transparent Data Encryption (TDE), or Transparent Sensitive Data Protection (TSDP).

What Is the Difference Between Oracle Virtual Private Database and Oracle Label Security?

Oracle Virtual Private Database (VPD) is provided at no additional cost with the Enterprise Edition of Oracle Database.

Oracle Label Security is an add-on security option for the Oracle Database Enterprise Edition.

Oracle VPD is a term used for several powerful security features like, fine grained access control (FGAC), application context and global application context. VPD policies are written using `PL/SQL`, and can be assigned to an individual table or view.

An information request, that accesses a table or view protected by VPD, is modified according to the policy assigned to the table or view.

VPD policies can be as simple as enforcing access during business hours. VPD policies can restrict access by comparing the value of an attribute in an individual row with an application context value. Global application context allows an application context to be accessed across multiple database sessions, reducing or eliminating the need to create a separate application context for each user session.

Oracle Label Security is an out-of-the-box solution for row level security. No coding or software development is required, allowing the administrator to focus completely on the policy. Oracle Label Security provides an interface for creating policies, specifying enforcement options, defining data sensitivity labels, establishing user label authorizations, and protecting individual tables or schemes.

Data sensitivity labels provide a powerful and flexible method of restricting access to data. For example, data belonging to different organizations or companies can be separated using data sensitivity labels and selectively shared between companies by changing the data sensitivity label.

Depending on the complexity of the security policy, Oracle Virtual Private Database may be the preferred method for implementing your security policy. Oracle Label Security is best suited for situations where access control decisions need to be based on the sensitivity of the information.

Can I Combine Oracle Virtual Private Database and Oracle Label Security?

Yes. You can use a `WHERE` clause or a VPD policy.

- A `WHERE` clause can be appended to an OLS policy, which provides one more level of granularity. An example would be that users, regardless of their label authorizations, are only allowed to connect from a specific IP address or subnet, and during business hours only.
- A VPD policy, whether column sensitive or not, can evaluate user labels and determine access to columns and rows without the need to apply data labels.

Can I Use Oracle Label Security with Oracle E-Business Suite?

Oracle Applications use Oracle Virtual Private Database (VPD) to provide new functionality and security protections.

In addition, you can use other Oracle security products with Oracle E-Business Suite, such as Oracle Database Vault. Contact Oracle Support for more information.

Can I Use Oracle Label Security with Oracle Database Vault?

You can protect Oracle Database Vault tables using Oracle Label Security just as you would do for an Oracle Database table.

In addition, Oracle Label Security can be used together with Database Vault features. You can assign Oracle Label Security labels to Database Vault Factors. These labels are then merged with the user clearance labels, following the algorithms documented in [Merging Labels with the MERGE_LABEL Function](#), before access control decisions are being made by comparing the merged user labels with the row labels.

The following example on the Oracle Technology Network Web site discusses using Oracle Label security along with Oracle Database Vault features:

<http://www.oracle.com/technetwork/database/security/label-security-factors-093209.html>

Does Oracle Label Security Provide Column-Level Access Control?

No, Oracle Label Security is not column aware.

This behavior is available with Virtual Private Database (VPD). A VPD policy can be written so that it only becomes active when a certain column is part of a SQL statement against a protected table. If the *column sensitivity* switch is on, then VPD either returns only those rows for which the sensitive column values are accessible to the user, or it returns all rows with all cells in the sensitive column being empty, except those values that the user is allowed to see.

The following link on the Oracle Technology Network Web site contains an example:

<http://www.oracle.com/technetwork/database/security/index-088277.html>

A column-sensitive VPD policy can determine access to a specific column by evaluating OLS user labels, which this example demonstrates:

<http://www.oracle.com/technetwork/database/security/ols-cs1-099558.html>

Can I Base Secure Application Roles on Oracle Label Security?

Yes, you can base secure application roles on Oracle Label Security.

The procedure that determines if the `SET ROLE` command is executed can evaluate OLS user labels. In this case, the OLS policy does not need to be applied to a table, since row labels are not part of this solution.

What Are Trusted Stored Program Units?

Trusted stored program units are stored procedures, functions, and packages that execute with the system and object privileges (DAC) of the definer.

If the invoker is a user with Oracle Label Security user clearances (labels), the procedure executes with a combination of the definer's DAC privileges and the invoker's security clearances.

Trusted stored procedures are procedures that are either granted the Oracle Label Security privilege `FULL` or `READ`. When a trusted stored program unit is run, the policy

privileges in force are a combination of the invoking user's privileges and the program unit's privileges.

Does VPD or OLS Add an Additional Column to the Protected Table?

When you apply an Oracle Label Security (OLS) policy to a table, the policy adds an additional column to the table.

The name of this column needs to be specified when the policy is initially created.

An existing column can be used to store the OLS row labels. This column must have the `NUMBER(10)` data type.

Oracle Virtual Private Database (VPD) does not add an additional column to the protected table.

Why Should the Additional OLS Row Label Column Be Hidden?

Most applications are designed with access control mechanisms in mind, so Oracle Label Security must do this transparently.

When an application queries a table with a `SELECT FROM tablename` statement, it returns all columns, including the unhidden label column. Existing applications may not be designed to display an additional column, and malfunction. However, if the label column is hidden, then it is displayed only when its name is included in the SQL statement. A `SELECT FROM tablename` would return all columns as expected by the application, excluding the hidden OLS column.

Index

A

access control
 discretionary, [3-17](#)
 understanding, [3-1](#)

access mediation
 and views, [3-18](#)
 enforcement options, [3-19](#)
 introduction, [3-1](#)
 label evaluation, [3-8](#)
 program units, [3-18](#)

ADD_GROUPS procedure
 inverse groups, [13-16](#)

ALL_CONTROL option, [8-3](#), [8-4](#), [8-9](#)

ALL_SA_AUDIT_OPTIONS view, [F-4](#)

ALL_SA_COMPARTMENTS view, [F-5](#), [F-13](#)

ALL_SA_DATA_LABELS view, [F-5](#), [F-13](#)

ALL_SA_GROUPS view, [F-6](#), [F-14](#)

ALL_SA_LABELS view, [F-6](#)

ALL_SA_LEVELS view, [F-7](#)

ALL_SA_POLICIES view, [F-7](#)

ALL_SA_PROG_PRIVS view, [F-8](#)

ALL_SA_SCHEMA_POLICIES view, [F-8](#)

ALL_SA_TABLE_POLICIES view, [F-9](#)

ALL_SA_USER_LABELS view, [F-11](#)

ALL_SA_USER_LEVELS view, [F-12](#)

ALL_SA_USER_PRIVS view, [F-12](#)

ALL_SA_USERS view, [F-10](#)

ALTER_GROUP_PARENT
 inverse groups, [13-20](#)

ALTER_GROUPS procedure
 inverse groups, [13-17](#)

ALTER_POLICY procedure
 inverse groups, [13-16](#)

ANALYZE command, [12-7](#)

APPLY_SCHEMA_POLICY procedure
 with inverse groups, [13-3](#)

APPLY_TABLE_POLICY procedure
 with inverse groups, [13-3](#)

architecture, Oracle Label Security, [1-4](#)

AS SYSDBA clause, [12-11](#)

AUDIT_LABEL_ENABLED function, [E-5](#)

AUDIT_TRAIL parameter, [10-2](#)

auditing
 audit trails, [10-1](#), [10-2](#), [E-5](#)

auditing (*continued*)
 creating audit view, [E-5](#)
 disabling, [E-8](#)
 dropping audit view, [E-6](#)
 enabling
 SA_AUDIT_ADMIN.AUDIT procedure, [E-2](#)
 finding audit options, [F-4](#)
 finding if labels are recorded, [E-5](#)
 Oracle Label Security, [10-1](#), [10-3](#)
 recording policy labels, [E-4](#)
 SA_AUDIT_ADMIN package, [E-2](#)
 SA_AUDIT_ADMIN.AUDIT_LABEL procedure,
 [E-4](#)
 SA_AUDIT_ADMIN.AUDIT_LABEL_ENABLED
 function, [E-5](#)
 SA_AUDIT_ADMIN.CREATE_VIEW
 procedure, [E-5](#)
 SA_AUDIT_ADMIN.DROP_VIEW procedure,
 [E-6](#)
 SA_AUDIT_ADMIN.NOAUDIT_LABEL
 procedure, [E-8](#)
 strategy, [10-4](#)
 systemwide, [10-2](#)
 types of, [5-27](#)
 views, [E-5](#)

B

B-tree indexes, [12-7](#)

C

CDB_OLS_STATUS data dictionary view, [4-2](#)

CDB_OLS_STATUS view, [F-12](#)

CDBs, [1-7](#)
 Oracle Label Security, [1-7](#)

CHAR_TO_LABEL function, [6-6](#), [6-15](#), [6-16](#)

CHECK_CONTROL option
 and label update, [8-16](#), [8-17](#)
 and labeling functions, [8-15](#)
 definition, [8-4](#)
 with other options, [8-9](#)

CHECK_WRITE function, [E-74](#)

child rows
 deleting, [8-18](#)

child rows (*continued*)
 inserting, [8-15](#)
 updating, [8-17](#)

Cloud Control login, [5-21](#)

COMPACCESS privilege, [3-15](#)
 inverse groups, [13-7](#), [13-9](#)

compartments
 altering, [E-10](#)
 creating, [E-14](#)
 definition, [2-5](#), [5-6](#)
 deleting, [E-17](#)
 example, [2-5](#), [5-6](#)
 finding, [F-17](#)
 finding compartments user can read in session,
[E-36](#)
 finding compartments user can write to in
 session, [E-36](#)
 finding user information, [F-5](#)
 SA_COMPONENTS.ALTER_COMPARTMENT
 procedure, [E-10](#)
 SA_COMPONENTS.CREATE_COMPARTMENT
 procedure, [E-14](#)
 SA_COMPONENTS.DROP_COMPARTMENT
 procedure, [E-17](#)
 SA_USER_ADMIN package, [E-53](#)
 SA_USER_ADMIN.ADD_COMPARTMENTS
 procedure, [E-54](#)
 SA_USER_ADMIN.ALTER_COMPARTMENTS,
[E-56](#)
 SA_USER_ADMIN.DROP_COMPARTMENTS
 procedure, [E-60](#)
 SA_USER_ADMIN.SET_COMPARTMENTS
 procedure, [E-62](#)
 setting authorizations, [3-6](#), [5-13](#)

components
 SA_COMPONENT package, [E-10](#)
 SA_USER_ADMIN.DROP_ALL_COMPARTMENTS
 procedure, [E-58](#)

CON, [C-15](#)

configuration of Oracle Label security
 finding status, [F-18](#)
 finding status in multitenant environment,
[F-12](#)

connection parameters, [C-15](#)

CREATE FUNCTION statement, [9-3](#)

CREATE PACKAGE BODY statement, [9-3](#)

CREATE PACKAGE statement, [9-3](#)

CREATE PROCEDURE statement, [9-3](#)

CREATE TABLE AS SELECT statement, [F-21](#)

CREATE_GROUP procedure
 inverse groups, [13-20](#)

CREATE_POLICY procedure
 inverse groups, [13-16](#)

creating databases, [12-10](#)

D

data
 label-based access, [2-1](#)

data dictionary tables, [2-2](#), [12-7](#), [12-10](#), [F-1](#)

data labels
 checking if label is data label, [E-75](#)
 finding label and tag information, [F-5](#)
 SA_UTL.DATA_LABEL function, [E-75](#)

Data Pump export
 row labels, [12-2](#)

Data Pump import, [12-2](#)

database links, [11-2](#)

databases, creating additional, [12-10](#)

DBA_OLS_STATUS view, [F-18](#)

DBA_policyname_AUDIT_TRAIL view, [F-20](#)

DBA_SA_AUDIT_OPTIONS view, [F-13](#)

DBA_SA_COMPARTMENTS view, [12-4](#), [F-13](#)

DBA_SA_DATA_LABELS view, [F-13](#)

DBA_SA_GROUP_HIERARCHY view, [F-14](#)

DBA_SA_GROUPS view, [12-4](#), [F-14](#)

DBA_SA_LABELS view, [12-4](#), [F-15](#)

DBA_SA_LEVELS view, [12-4](#), [F-15](#)

DBA_SA_POLICIES view, [F-15](#)

DBA_SA_PROG_PRIVS view, [F-16](#)

DBA_SA_SCHEMA_POLICIES view, [8-11](#), [F-16](#)

DBA_SA_TABLE_POLICIES view, [8-11](#), [F-16](#)

DBA_SA_USER_COMPARTMENTS view, [F-17](#)

DBA_SA_USER_GROUPS view, [F-17](#)

DBA_SA_USER_LABELS view, [F-18](#)

DBA_SA_USER_LEVELS view, [F-18](#)

DBA_SA_USER_PRIVS view, [F-18](#)

DBA_SA_USERS view, [F-16](#)

default port, [C-15](#)

default row label, [E-46](#)

DELETE_CONTROL option, [8-4](#), [8-18](#)

DELETERESTRICT option, [8-18](#)

deleting labeled data, [8-18](#)

demobld.sql file, [1-6](#)

disabling OLS, [A-1](#)

disabling Oracle Label Security, [A-1](#)

discretionary access control (DAC), [3-17](#)

distributed databases
 connecting to, [11-2](#)
 multiple policies, [3-20](#)
 Oracle Label Security configuration, [11-1](#)
 remote session label, [11-3](#)

dominance
 definition, [3-9](#)
 functions
 about, [B-3](#)
 greatest lower bound, [6-12](#)
 inverse groups, [13-21](#)
 least upper bound, [6-11](#)
 overview, [B-1](#)

DOMINATED_BY function, [B-10](#)
 DOMINATES function, [B-1](#)
 DROP USER CASCADE restriction, [F-21](#)
 dropping for specified compartments, [E-60](#)
 duties
 of security administrators, [1-2](#)

E

enabling OLS, [A-1](#)
 enforcement options
 and UPDATE, [8-16](#)
 combinations of, [8-9](#)
 exemptions, [8-10](#)
 guidelines, [8-9](#)
 INVERSE_GROUP, [13-3](#)
 list of, [8-2](#)
 overview, [8-2](#)
 viewing, [8-11](#)
 EXEMPT ACCESS POLICY privilege, [8-10](#)
 Export utility
 LBACSYS restriction, [F-21](#)
 policy enforcement, [8-10](#)
 row labels, [3-14](#), [12-4](#)
 external tables, [5-17](#)

F

FULL privilege, [3-15](#), [3-16](#)
 function call, [D-1](#), [D-2](#)

G

granularity
 to data access, [3-11](#)
 GREATEST_LBOUND function
 inverse groups, [13-21](#)
 groups
 altering, [E-11](#)
 altering parent groups, [E-12](#)
 creating group parent, [E-15](#)
 definition, [2-7](#), [5-8](#)
 deleting, [E-18](#)
 example, [2-7](#), [5-8](#)
 finding for entire database, [F-17](#)
 finding hierarchy of parent-child relationships,
 [F-14](#)
 finding policy groups, [F-6](#)
 hierarchical, [2-7](#), [2-10](#), [5-8](#), [F-14](#)
 inverse, [13-2](#)
 parent, [2-7](#), [3-9](#), [5-8](#), [13-6](#)
 read/write access, [3-9](#)
 SA_COMPONENTS.ALTER_GROUP
 procedure, [E-11](#)

groups (*continued*)
 SA_COMPONENTS.ALTER_GROUP_PARENT
 procedure, [E-12](#)
 SA_COMPONENTS.CREATE_GROUP
 procedure, [E-15](#)
 SA_COMPONENTS.DROP_GROUP, [E-18](#)
 SA_SESSION.GROUP_READ function, [E-37](#)
 SA_SESSION.GROUP_WRITE function, [E-37](#)
 SA_USER_ADMIN package, [E-53](#)
 SA_USER_ADMIN.ADD_GROUPS procedure,
 [E-55](#)
 SA_USER_ADMIN.ALTER_GROUPS
 procedure, [E-57](#)
 SA_USER_ADMIN.DROP_ALL_GROUPS
 procedure, [E-59](#)
 SA_USER_ADMIN.DROP_GROUPS
 procedure, [E-60](#)
 SA_USER_ADMIN.SET_GROUPS procedure,
 [E-64](#)
 setting authorizations, [3-6](#), [5-14](#)

H

HIDE, [6-2](#), [E-48](#), [E-49](#)
 HIDE option
 default, [E-49](#)
 discussion of, [8-6](#)
 example, [6-2](#)
 importing hidden column, [12-5](#)
 inserting data, [6-16](#)
 not exported, [12-2](#)
 per-table basis, [6-8](#)
 PL/SQL restriction, [F-21](#)
 policy label column
 inserting data when hidden, [6-16](#)
 schema level, [8-2](#)

I

impdp
 See Data Pump import
 Import utility
 importing labeled data, [12-4](#)
 importing policies, [12-2](#)
 importing unlabeled data, [12-5](#)
 with Oracle Label Security, [12-3](#)
 indexes, [12-7](#)
 INITIAL_LABEL variable, [B-13](#)
 INITIAL_ROW_LABEL variable, [B-13](#)
 initialization parameters
 AUDIT_TRAIL, [10-2](#)
 INSERT_CONTROL option, [8-4](#), [8-15](#)
 inserting labeled data, [6-14](#), [8-14](#)
 INTO TABLE clause, [12-6](#)
 inverse groups

- inverse groups (*continued*)
 - and label components, [13-4](#)
 - COMPACCESS privilege, [13-7](#), [13-9](#)
 - computed labels, [13-4](#)
 - dominance, [13-21](#)
 - implementation of, [13-3](#)
 - introduction, [13-2](#)
 - Max Read Groups, [13-5](#)
 - Max Write Groups, [13-5](#)
 - parent-child unsupported, [13-6](#)
 - read algorithm, [13-7](#)
 - session labels, [13-10](#)
 - SET_DEFAULT_LABEL, [13-11](#)
 - SET_LABEL, [13-12](#)
 - SET_ROW_LABEL, [13-11](#), [13-12](#)
 - user privileges, [13-7](#)
 - write algorithm, [13-8](#)
 - INVERSE_GROUP enforcement option
 - behavior of procedures, [13-15](#)
 - implementation, [13-3](#)
- ## L
-
- label components
 - defining, [E-10](#)
 - in distributed environment, [11-4](#)
 - industry examples, [2-9](#)
 - interrelation, [2-10](#)
 - label evaluation process
 - COMPACCESS read, [3-15](#)
 - COMPACCESS write, [3-15](#)
 - inverse groups, COMPACCESS, [13-9](#)
 - LABEL_UPDATE, [8-16](#)
 - read access, [3-9](#)
 - read access, inverse groups, [13-7](#)
 - write access, [3-11](#)
 - write access, inverse groups, [13-8](#)
 - label policy containers
 - creating, [5-3](#)
 - label tags
 - converting from string, [6-6](#)
 - converting to string, [6-7](#)
 - distributed environment, [11-4](#)
 - example, [6-4](#)
 - inserting data, [6-15](#)
 - introduction, [2-9](#), [5-10](#)
 - manually defined, [6-4](#)
 - strategy, [12-8](#)
 - using in WHERE clauses, [6-9](#)
 - LABEL_DEFAULT option
 - and labeling functions, [8-11](#), [8-12](#)
 - authorizing compartments, [3-6](#)
 - authorizing groups, [3-6](#)
 - importing unlabeled data, [12-5](#)
 - inserting labeled data, [6-15](#)
 - LABEL_DEFAULT option (*continued*)
 - with enforcement options, [8-9](#)
 - with SA_SESSION.SET_ROW_LABEL, [E-46](#)
 - LABEL_TO_CHAR function, [6-7](#), [6-10](#)
 - LABEL_UPDATE option
 - and labeling functions, [8-7](#), [8-12](#)
 - and privileges, [8-7](#)
 - and WRITE_CONTROL, [8-8](#)
 - and WRITEUP, [3-13](#), [5-15](#)
 - definition, [8-4](#)
 - evaluation process, [8-16](#)
 - with enforcement options, [8-9](#)
 - label-based security, [2-1](#)
 - labeling functions
 - ALL_CONTROL and NO_CONTROL, [8-9](#)
 - and CHECK_CONTROL, [8-15](#)
 - and LABEL_DEFAULT, [8-7](#), [8-11](#)
 - and LABEL_DEFAULT/LABEL_DEFAULT option
 - and labeling functions, [8-7](#)
 - and LABEL_UPDATE, [8-6](#), [8-7](#)
 - and LBACSYS, [8-12](#)
 - creating, [8-13](#)
 - example, [8-11](#)
 - how they work, [8-12](#)
 - importing unlabeled data, [12-5](#)
 - in force, [8-6](#)
 - inserting data, [6-15](#)
 - introduction, [3-19](#)
 - override manual insert, [8-15](#)
 - specifying, [8-14](#)
 - testing, [8-12](#)
 - UPDATE, [8-17](#)
 - using, [8-11](#)
 - with enforcement options, [8-9](#)
 - labels, [E-75](#), [E-78](#)
 - administering, [2-12](#)
 - altering, [E-20](#)
 - and performance, [3-14](#)
 - checking if a data label, [E-75](#)
 - checking if changed, [E-73](#)
 - creating, [E-21](#)
 - data and user, [2-10](#)
 - deleting, [E-22](#)
 - finding greatest lower bound, [E-76](#)
 - finding least upper bound, [E-76](#)
 - finding tags and types of, [F-6](#)
 - merging, [6-12](#)
 - non-comparable, [B-2](#)
 - relationships between, [B-1](#)
 - restoring default for session, [E-42](#)
 - SA_LABEL_ADMIN package, [E-20](#)
 - SA_LABEL_ADMIN.ALTER_LABEL procedure, [E-20](#)

labels (*continued*)

- SA_LABEL_ADMIN.CREATE_LABEL procedure, [E-21](#)
 - SA_LABEL_ADMIN.DROP_LABEL procedure, [E-22](#)
 - SA_SESSION.LABEL function, [E-38](#)
 - SA_SESSION.MAX_READ_LABEL function, [E-39](#)
 - SA_SESSION.MAX_WRITE_LABEL function, [E-40](#)
 - SA_SESSION.MIN_WRITE_LABEL function, [E-41](#)
 - SA_SESSION.RESTORE_DEFAULT_LABELS, [E-42](#)
 - SA_SESSION.SET_LABEL procedure, [E-43](#)
 - SA_SESSION.SET_ROW_LABEL procedure, [E-46](#)
 - SA_USER_ADMIN package, [E-53](#)
 - SA_USER_ADMIN.SET_USER_LABELS procedure, [E-68](#)
 - SA_UTL.CHECK_LABEL_CHANGE function, [E-73](#)
 - SA_UTL.GREATEST_LBOUND function, [E-76](#)
 - SA_UTL.LEAST_UBOUND function, [E-76](#)
 - SA_UTL.SET_LABEL procedure, [E-78](#)
 - saving default session label, [E-44](#)
 - setting row label, [E-46](#)
 - syntax, [2-9](#), [5-10](#)
 - valid, [2-9](#), [5-10](#), [6-3](#)
 - with inverse groups, [13-4](#)
- LBAC_LABEL data type, [8-12](#)
- LBACSYS
- export, [12-1](#)
 - import, [12-1](#)
 - login, [5-21](#)
- LBACSYS default user account
- about, [4-4](#)
 - best practice guideline, [4-4](#)
 - enabling, [4-4](#)
- LBACSYS schema
- and labeling functions, [8-12](#)
 - creating additional databases, [12-10](#)
 - data dictionary tables, [12-7](#)
 - export restriction, [F-21](#)
- LEAST_UBOUND function
- inverse groups, [13-21](#)
- levels
- about, [5-4](#)
 - altering levels, [E-13](#)
 - creating, [E-16](#)
 - definition, [2-4](#), [5-4](#)
 - deleting, [E-19](#)
 - example, [2-4](#), [5-4](#)
 - finding, [F-7](#)

levels (*continued*)

- SA_COMPONENTS.ALTER_LEVEL procedure, [E-13](#)
 - SA_COMPONENTS.CREATE_LEVEL procedure, [E-16](#)
 - SA_COMPONENTS.DROP_LEVEL procedure, [E-19](#)
 - SA_SESSION.MAX_LEVEL function, [E-39](#)
 - SA_SESSION.MIN_LEVEL function, [E-40](#)
 - SA_USER_ADMIN.SET_LEVELS procedure, [E-65](#)
 - setting authorizations, [3-5](#), [5-12](#)
- logging into Oracle Label Security
- from Cloud Control, [4-5](#)
 - from SQL*Plus, [4-6](#)
- login
- Cloud Control, [5-21](#)
 - LBACSYS, [5-21](#)

M

- materialized views, [11-6](#), [11-9](#)
- Max Read Groups, [13-5](#)
- Max Write Group, [13-5](#)
- MERGE_LABEL function, [6-12](#)
- multitenant container databases
- See CDBs

N

- NO_CONTROL option, [8-4](#), [8-9](#)
- NUMBER data type, [6-2](#)

O

- object privileges
- and Oracle Label Security privileges, [3-17](#)
 - and trusted stored program units, [3-18](#), [9-2](#)
- OCI interface, [B-13](#)
- OCI_ATTR_APPCTX_LIST, [B-13](#)
- OCI_ATTR_APPCTX_SIZE, [B-13](#)
- OCIAttrSet, [B-13](#)
- OCIParmGet, [B-13](#)
- OLS_DOMINATED_BY function, [B-6](#)
- OLS_DOMINATES function, [B-3](#)
- OLS_GLBD function, [6-12](#)
- OLS_GREATEST_LBOUND function, [6-12](#)
- OLS_LABEL_DOMINATES function
- about, [B-4](#)
 - in Data Redaction policies, [B-4](#)
 - in Database Vault policies, [B-4](#)
- OLS_LEAST_UBOUND function, [6-11](#)
- OLS_LUBD function, [6-11](#)
- OLS_STRICTLY_DOMINATED_BY function, [B-7](#)
- OLS_STRICTLY_DOMINATES function, [B-6](#)

OptionsA, [C-16](#)

Oracle Data Redaction
using OLS_LABEL_DOMINATES function
with, [B-4](#)

Oracle Database Vault
using OLS_LABEL_DOMINATES function
with, [B-4](#)

Oracle Enterprise Manager
administering labels, [2-12](#)

Oracle Internet Directory
configuring OLS after switchover to standby
database, [7-19](#)
integration with OLS, [1-7](#)
OID with Oracle Data Guard, [7-19](#)

Oracle Label Security
about, [7-2](#)
administrator duties in, [7-14](#)
bootstrapping databases, [7-14](#)
configuring, about, [7-6](#)
configuring, permission for, [7-7](#)
configuring, steps, [7-7](#)
integrated capabilities of, [7-11](#)
PL/SQL procedures for policy
administrators, [7-23](#)
policy attributes in, [7-12](#)
profiles, about, [7-10](#)
provisioning profiles, about, [7-16](#)
provisioning profiles, changing database
connection information, [7-18](#)
provisioning profiles, managing, [7-17](#)
restrictions on new data label creation,
[7-13](#)
security roles and permitted actions, [7-21](#)
subscribing policies in, [7-13](#)
superseded PL/SQL statements, [7-22](#)
synchronizing database with OID, [7-15](#)
un-registering database, [7-10](#)

Oracle Label Security
about, [1-1](#)
benefits, [1-2](#)
checking if registered and enabled, [4-2](#)
DBA_OLS_STATUS data dictionary view,
[4-2](#)
privileges required to use, [1-2](#)
registering, [4-1](#)

Oracle Label Security (OLS)
integration with Oracle Internet Directory, [1-7](#)

Oracle Label Security data dictionary views
about, [F-1](#)
ALL_SA_AUDIT_OPTIONS, [F-4](#)
ALL_SA_COMPARTMENTS, [F-5](#), [F-13](#)
ALL_SA_DATA_LABELS, [F-5](#), [F-13](#)
ALL_SA_GROUPS, [F-6](#), [F-14](#)
ALL_SA_LABELS, [F-6](#)
ALL_SA_LEVELS, [F-7](#), [F-15](#)

Oracle Label Security data dictionary views (*continued*)

ALL_SA_POLICIES, [F-7](#)
ALL_SA_PROG_PRIVS, [F-8](#)
ALL_SA_SCHEMA_POLICIES, [F-8](#)
ALL_SA_TABLE_POLICIES, [F-9](#)
ALL_SA_USER_LABELS, [F-11](#)
ALL_SA_USER_LEVELS, [F-12](#)
ALL_SA_USER_PRIVS, [F-12](#)
ALL_SA_USERS, [F-10](#)
CDB_OLS_STATUS, [F-12](#)
DBA_OLS_STATUS, [F-18](#)
DBA_SA_AUDIT_OPTIONS, [F-13](#)
DBA_SA_GROUP_HIERARCHY, [F-14](#)
DBA_SA_LABELS, [F-15](#)
DBA_SA_POLICIES, [F-15](#)
DBA_SA_PROG_PRIVS, [F-16](#)
DBA_SA_SCHEMA_POLICIES, [F-16](#)
DBA_SA_TABLE_POLICIES, [F-16](#)
DBA_SA_USER_COMPARTMENTS, [F-17](#)
DBA_SA_USER_GROUPS, [F-17](#)
DBA_SA_USER_LABELS, [F-18](#)
DBA_SA_USER_LEVELS, [F-18](#)
DBA_SA_USER_PRIVS, [F-18](#)
DBA_SA_USERS, [F-16](#)
policies
finding information about schema
policies, [F-8](#)
USER_SA_SESSION, [F-19](#)

Oracle Label Security profiles, [7-10](#)

ORDER BY clause, [6-10](#)

P

packages

Oracle Label Security, [1-5](#)
SA_AUDIT_ADMIN, [E-2](#)
SA_COMPONENTS, [E-10](#)
SA_LABEL_ADMIN, [E-20](#)
SA_POLICY_ADMIN, [E-24](#)
SA_SESSION, [E-35](#)
SA_SYSDBA, [E-48](#)
SA_USER_ADMIN, [E-53](#)
SA_UTL, [E-72](#)
trusted stored program units, [9-1](#)

partitioning, [6-4](#), [12-9](#)

PDBs, [1-7](#)
Oracle Label Security, [1-7](#)

performance, Oracle Label Security
ANALYZE command, [12-7](#)
indexes, [12-7](#)
label tag strategy, [12-8](#)
partitioning, [12-9](#)
READ privilege, [3-14](#)

PL/SQL
recreating labels for import, [12-4](#)

- PL/SQL (*continued*)
 - SA_UTL package, [9-5](#), [E-72](#)
 - trusted stored program units, [9-1](#)
- pluggable databases
 - See PDBs
- policies
 - about creating, [5-17](#)
 - enforcement guidelines, [8-9](#)
 - enforcement options, [3-19](#), [6-1](#), [8-2](#), [8-9](#)
 - finding for current user, [F-7](#)
 - finding for entire database, [F-15](#)
 - finding information about table policies, [F-9](#)
 - finding privileges for program units, [F-8](#)
 - multiple, [2-2](#), [6-3](#)
 - OID subscription, [E-31](#)
 - OID unsubscription, [E-32](#)
 - privileges, [3-17](#), [E-70](#)
 - SA_POLICY_ADMIN package, [E-24](#)
 - SA_POLICY_ADMIN.POLICY_SUBSCRIBE procedure, [E-31](#)
 - SA_POLICY_ADMIN.POLICY_UNSUBSCRIBE procedure, [E-32](#)
- policies, schema
 - altering, [E-25](#)
 - applying, [E-26](#)
 - deleting, [E-32](#)
 - disabling, [E-27](#)
 - enabling, [E-29](#)
 - SA_POLICY_ADMIN.ALTER_SCHEMA_POLICY procedure, [E-25](#)
 - SA_POLICY_ADMIN.APPLY_SCHEMA_POLICY procedure, [E-26](#)
 - SA_POLICY_ADMIN.ENABLE_SCHEMA_POLICY policy, [E-29](#)
 - SA_POLICY_ADMIN.REMOVE_SCHEMA_POLICY procedure, [E-32](#)
- policies, schema, disabling
 - SA_POLICY_ADMIN.DISABLE_SCHEMA_POLICY procedure, [E-27](#)
- policies, table
 - applying, [E-26](#)
 - deleting, [E-33](#)
 - disabling, [E-28](#)
 - enabling, [E-30](#)
 - SA_POLICY_ADMIN.APPLY_TABLE_POLICY procedure, [E-26](#)
 - SA_POLICY_ADMIN.DISABLE_TABLE_POLICY procedure, [E-28](#)
 - SA_POLICY_ADMIN.ENABLE_TABLE_POLICY procedure, [E-30](#)
 - SA_POLICY_ADMIN.REMOVE_TABLE_POLICY procedure, [E-33](#)
- policy label column
 - indexing, [12-7](#)
 - introduction, [6-2](#)
- policy label column (*continued*)
 - retrieving, [6-7](#)
 - retrieving hidden, [6-8](#)
 - storing label tag, [2-9](#), [5-10](#)
- policy label containers
 - about, [5-2](#)
- policy management
 - altering policies, [E-48](#)
 - creating policies, [E-49](#)
 - deleting policies, [E-51](#)
 - disabling policies, [E-50](#)
 - enabling policies, [E-52](#)
 - SA_SYSDBA package, [E-48](#)
 - SA_SYSDBA.ALTER_POLICY procedure, [E-48](#)
 - SA_SYSDBA.CREATE_POLICY procedure, [E-49](#)
 - SA_SYSDBA.DISABLE_POLICY procedure, [E-50](#)
 - SA_SYSDBA.DROP_POLICY policy, [E-51](#)
 - SA_SYSDBA.ENABLE_POLICY procedure, [E-52](#)
- policy_DBA role, [2-2](#), [E-20](#), [E-70](#)
 - about, [1-2](#)
 - auditing policy_DBA role users, [E-2](#)
 - how to use, [1-2](#)
 - required for Data Pump import operations, [12-4](#)
 - required for label management, [E-20](#)
 - required for Oracle Label Security auditing, [E-2](#)
 - required for
 - SA_USER_ADMIN.SET_PROG_PRIVS procedure, [E-66](#)
 - required for
 - SA_USER_ADMIN.SET_USER_PRIVS procedure, [E-70](#)
- predicates
 - access mediation, [3-19](#)
 - errors, [8-19](#)
 - label tag performance strategy, [12-8](#)
 - multiple, [8-19](#)
 - used with policy, [8-19](#)
- privileges
 - COMPACCESS, [3-15](#)
 - FULL, [3-15](#), [3-16](#)
 - Oracle Label Security, [1-2](#), [3-13](#)
 - PROFILE_ACCESS, [3-16](#)
 - program units, [3-18](#)
 - READ, [3-13](#), [3-14](#), [5-15](#)
 - row label, [3-16](#)
 - SA_USER_ADMIN.SET_USER_PRIVS procedure, [E-70](#)
 - trusted stored program units, [9-4](#)
 - WRITEACROSS, [3-16](#), [3-17](#)
 - WRITEDOWN, [3-16](#), [3-18](#)
 - WRITEUP, [3-16](#), [3-17](#)

PROFILE_ACCESS privilege, [3-16](#)
 program units
 finding policy privileges for, [F-8](#)
 propagated, [D-1](#)

R

RAC, [D-1](#)
 re-enabling Oracle Label Security, [A-1](#)
 read access
 algorithm, [3-9](#), [3-15](#)
 introduction, [3-8](#)
 read label, [3-7](#)
 READ privilege, [3-13](#), [3-14](#), [5-15](#)
 READ_CONTROL option
 algorithm, [3-9](#)
 and CHECK_CONTROL, [8-7](#)
 and child rows, [8-15](#)
 definition, [8-4](#)
 referential integrity, [8-17](#)
 with other options, [8-9](#)
 with predicates, [8-19](#)
 reading down, [3-9](#)
 referential integrity, [8-15](#), [8-17](#), [8-18](#)
 registering Oracle Label Security, [4-1](#)
 releasability, [13-2](#)
 remote users, [11-2](#)
 REPADMIN account, [11-9](#)
 replication
 materialized views (snapshots), [11-6](#), [11-9](#),
 [11-10](#)
 with Oracle Label Security, [11-6](#), [11-7](#)
 replication administrator, [11-9](#)
 restrictions, Oracle Label Security, [F-21](#)
 row labels
 default, [3-6](#), [3-7](#), [D-2](#), [E-35](#), [E-46](#), [E-79](#)
 example, [3-3](#)
 finding current, [E-78](#)
 in distributed environment, [11-3](#)
 inserting, [6-15](#)
 LABEL_DEFAULT option, [6-14](#), [8-7](#)
 privileges, [3-16](#)
 restoring, [E-42](#)
 SA_USER_ADMIN.SET_ROW_LABEL
 procedure, [E-67](#)
 SA_UTL.NUMERIC_ROW_LABEL function,
 [E-78](#)
 SA_UTL.SET_ROW_LABEL procedure, [E-79](#)
 saving defaults, [E-44](#)
 setting, [E-46](#), [E-79](#)
 setting compartments, [E-62](#)
 setting for current database session, [E-79](#)
 setting for user's initial use, [E-67](#)
 setting groups, [E-64](#)
 setting levels, [E-65](#)

row labels (*continued*)
 understanding, [3-3](#)
 updating, [3-16](#)
 viewing, [E-78](#)

S

SA_AUDIT_ADMIN
 procedures, listed, [E-2](#)
 SA_AUDIT_ADMIN PL/SQL package
 about, [E-2](#)
 SA_AUDIT_ADMIN.AUDIT procedure, [E-2](#)
 SA_AUDIT_ADMIN.AUDIT_LABEL procedure,
 [E-4](#)
 SA_AUDIT_ADMIN.AUDIT_LABEL_ENABLED
 procedure, [E-5](#)
 SA_AUDIT_ADMIN.CREATE_VIEW procedure,
 [E-5](#)
 SA_AUDIT_ADMIN.DROP_VIEW procedure, [E-6](#)
 SA_AUDIT_ADMIN.NOAUDIT procedure, [E-7](#)
 SA_AUDIT_ADMIN.NOAUDIT_LABEL
 procedure, [E-8](#)
 SA_COMPONENTS
 procedures, listed, [E-10](#)
 SA_COMPONENTS package, [E-10](#)
 SA_COMPONENTS PL/SQL package
 about, [E-10](#)
 SA_COMPONENTS.ALTER_COMPARTMENT
 procedure, [E-10](#)
 SA_COMPONENTS.ALTER_GROUP procedure,
 [E-11](#)
 SA_COMPONENTS.ALTER_GROUP_PARENT
 procedure, [E-12](#)
 SA_COMPONENTS.ALTER_LEVEL procedure,
 [E-13](#)
 SA_COMPONENTS.CREATE_COMPARTMENT
 procedure, [E-14](#)
 SA_COMPONENTS.CREATE_GROUP
 procedure, [E-15](#)
 SA_COMPONENTS.CREATE_LEVEL
 procedure, [E-16](#)
 SA_COMPONENTS.DROP_COMPARTMENT
 procedure, [E-17](#)
 SA_COMPONENTS.DROP_GROUP procedure,
 [E-18](#)
 SA_COMPONENTS.DROP_LEVEL procedure,
 [E-19](#)
 SA_LABEL_ADMIN
 procedures, listed, [E-20](#)
 SA_LABEL_ADMIN PL/SQL package
 about, [E-20](#)
 SA_LABEL_ADMIN.ALTER_LABEL procedure,
 [E-20](#)
 SA_LABEL_ADMIN.CREATE_LABEL procedure,
 [E-21](#)

- SA_LABEL_ADMIN.DROP_LABEL procedure, [E-22](#)
- SA_POLICY_ADMIN
 - procedures, listed, [E-24](#)
- SA_POLICY_ADMIN PL/SQL package
 - about, [E-24](#)
- SA_POLICY_ADMIN.ALTER_SCHEMA_POLICY procedure, [E-25](#)
- SA_POLICY_ADMIN.APPLY_SCHEMA_POLICY procedure, [E-26](#)
- SA_POLICY_ADMIN.APPLY_TABLE_POLICY procedure, [E-26](#)
- SA_POLICY_ADMIN.DISABLE_SCHEMA_POLICY procedure, [E-27](#)
- SA_POLICY_ADMIN.DISABLE_TABLE_POLICY procedure, [E-28](#)
- SA_POLICY_ADMIN.ENABLE_SCHEMA_POLICY procedure, [E-29](#)
- SA_POLICY_ADMIN.ENABLE_TABLE_POLICY procedure, [E-30](#)
- SA_POLICY_ADMIN.POLICY_SUBSCRIBE procedure, [E-31](#)
- SA_POLICY_ADMIN.POLICY_UNSUBSCRIBE procedure, [E-32](#)
- SA_POLICY_ADMIN.REMOVE_SCHEMA_POLICY procedure, [E-32](#)
- SA_POLICY_ADMIN.REMOVE_TABLE_POLICY procedure, [E-33](#)
- SA_SESSION
 - procedures and functions, listed, [E-35](#)
- SA_SESSION PL/SQL package
 - about, [E-35](#)
- SA_SESSION.COMP_READ function, [E-36](#)
- SA_SESSION.COMP_WRITE function, [E-36](#)
- SA_SESSION.GROUP_READ function, [E-37](#)
- SA_SESSION.GROUP_WRITE function, [E-37](#)
- SA_SESSION.LABEL function, [E-38](#)
- SA_SESSION.MAX_LEVEL function, [E-39](#)
- SA_SESSION.MAX_READ_LABEL function, [E-39](#)
- SA_SESSION.MAX_WRITE_LABEL function, [E-40](#)
- SA_SESSION.MIN_LEVEL function, [E-40](#)
- SA_SESSION.MIN_WRITE_LABEL function, [E-41](#)
- SA_SESSION.PRIVS function, [E-41](#)
- SA_SESSION.RESTORE_DEFAULT_LABELS procedure, [E-42](#)
- SA_SESSION.ROW_LABEL function, [E-42](#)
- SA_SESSION.SA_USER_NAME function, [E-44](#)
- SA_SESSION.SAVE_DEFAULT_LABELS procedure, [E-44](#)
- SA_SESSION.SET_ACCESS_PROFILE procedure, [E-44](#), [E-45](#)
- SA_SESSION.SET_LABEL procedure, [E-43](#)
- SA_SESSION.SET_LABEL procedure (*continued*)
 - and SA_SESSION.RESTORE_DEFAULT_LABELS, [E-42](#)
- SA_SESSION.SET_ROW_LABEL procedure, [E-46](#)
- SA_SYSDBA
 - procedures, listed, [E-48](#)
- SA_SYSDBA PL/SQL package
 - about, [E-48](#)
- SA_SYSDBA.ALTER_POLICY procedure, [E-48](#)
- SA_SYSDBA.CREATE_POLICY procedure, [E-49](#)
- SA_SYSDBA.DISABLE_POLICY procedure, [E-50](#)
- SA_SYSDBA.DROP_POLICY procedure, [E-51](#)
- SA_SYSDBA.ENABLE_POLICY procedure, [E-52](#)
- SA_USER_ADMIN package
 - administering stored program units, [E-66](#)
 - overview, [2-2](#)
 - procedures, listed, [E-53](#)
- SA_USER_ADMIN PL/SQL package
 - about, [E-53](#)
- SA_USER_ADMIN.ADD_COMPARTMENTS procedure, [E-54](#)
- SA_USER_ADMIN.ADD_GROUPS procedure, [E-55](#)
- SA_USER_ADMIN.ALTER_COMPARTMENTS procedure, [E-56](#)
- SA_USER_ADMIN.ALTER_GROUPS procedure, [E-57](#)
- SA_USER_ADMIN.DROP_ALL_COMPARTMENTS procedure, [E-58](#)
- SA_USER_ADMIN.DROP_ALL_GROUPS procedure, [E-59](#)
- SA_USER_ADMIN.DROP_COMPARTMENTS procedure, [E-60](#)
- SA_USER_ADMIN.DROP_GROUPS procedure, [E-60](#)
- SA_USER_ADMIN.DROP_USER_ACCESS procedure, [E-61](#)
- SA_USER_ADMIN.SET_COMPARTMENTS procedure, [E-62](#)
- SA_USER_ADMIN.SET_DEFAULT_LABEL procedure, [E-63](#)
- SA_USER_ADMIN.SET_GROUPS procedure, [E-64](#)
- SA_USER_ADMIN.SET_LEVELS procedure, [E-65](#)
- SA_USER_ADMIN.SET_ROW_LABEL procedure, [E-67](#)
- SA_USER_ADMIN.SET_USER_LABELS procedure, [E-68](#)
- SA_USER_ADMIN.SET_USER_PRIVS procedure, [E-70](#)
- SA_UTL package

- SA_UTL package (*continued*)
 - dominance functions, [B-8](#)
 - overview, [9-5](#)
 - procedures and functions, listed, [E-72](#)
- SA_UTL PL/SQL package
 - about, [E-72](#)
- SA_UTL.CHECK_LABEL_CHANGE function, [E-73](#)
- SA_UTL.CHECK_READ function, [E-74](#)
- SA_UTL.CHECK_WRITE function, [E-74](#)
- SA_UTL.DATA_LABEL function, [E-75](#)
- SA_UTL.GREATEST_LBOUND function, [E-76](#)
- SA_UTL.LEAST_UBOUND function, [E-76](#)
- SA_UTL.NUMERIC_LABEL function, [E-77](#)
- SA_UTL.NUMERIC_ROW_LABEL function, [E-78](#)
- SA_UTL.SET_LABEL procedure, [E-78](#)
- SA_UTL.SET_ROW_LABEL procedure, [E-79](#)
- schemas
 - applying policies to, [8-9](#), [E-48](#)
 - default policy options, [E-49](#)
 - restrictions on shared, [F-21](#)
- session labels
 - changing, [E-43](#)
 - computed, [3-7](#)
 - distributed database, [11-3](#)
 - example, [3-3](#)
 - finding, [E-77](#)
 - OCI interface, [B-13](#)
 - restoring to default, [E-42](#)
 - SA_UTL.SET_LABEL, [E-78](#)
 - saving defaults, [E-44](#)
 - setting compartments, [E-62](#)
 - setting groups, [E-64](#)
 - setting user initial, [E-63](#)
 - understanding, [3-3](#)
- sessions
 - compartments readable by user, [E-36](#)
 - compartments writeable by user, [E-36](#)
 - finding current OLS user, [E-44](#)
 - finding row label, [E-42](#)
 - finding security attributes for, [F-19](#)
 - finding session label number, [E-77](#)
 - finding session privileges, [E-41](#)
 - SA_SESSION package, [E-35](#)
 - SA_SESSION.COMP_READ function, [E-36](#)
 - SA_SESSION.COMP_WRITE function, [E-36](#)
 - SA_SESSION.GROUP_READ function, [E-37](#)
 - SA_SESSION.GROUP_WRITE function, [E-37](#)
 - SA_SESSION.LABEL function, [E-38](#)
 - SA_SESSION.MAX_LEVEL function, [E-39](#)
 - SA_SESSION.MAX_READ_LABEL function, [E-39](#)
 - SA_SESSION.MAX_WRITE_LABEL function, [E-40](#)
 - SA_SESSION.MIN_LEVEL function, [E-40](#)
- sessions (*continued*)
 - SA_SESSION.MIN_WRITE_LABEL function, [E-41](#)
 - SA_SESSION.PRIVS, [E-41](#)
 - SA_SESSION.RESTORE_DEFAULT_LABELS procedure, [E-42](#)
 - SA_SESSION.ROW_LABEL function, [E-42](#)
 - SA_SESSION.SA_USER_NAME function, [E-44](#)
 - SA_SESSION.SAVE_DEFAULT_LABELS procedure, [E-44](#)
 - SA_SESSION.SET_ACCESS_PROFILE procedure, [E-45](#)
 - SA_SESSION.SET_LABEL procedure, [E-43](#)
 - SA_USER_ADMIN.SET_COMPARTMENTS procedure, [E-62](#)
 - SA_USER_ADMIN.SET_DEFAULT_LABEL procedure, [E-63](#)
 - SA_USER_ADMIN.SET_LEVELS procedure, [E-65](#)
 - SA_UTL.SET_LABEL procedure, [E-78](#)
 - SA_UTL.SET_ROW_LABEL procedure, [E-79](#)
 - saving default session label, [E-44](#)
 - setting label for, [E-78](#)
 - setting OLS privileges for user, [E-45](#)
 - setting row label for, [E-79](#)
- SET_ACCESS_PROFILE procedure, [F-21](#)
- SET_DEFAULT_LABEL procedure
 - inverse groups, [13-11](#), [13-19](#)
- SET_GROUPS procedure
 - inverse groups, [13-17](#)
- SET_LABEL procedure
 - definition, [E-35](#)
 - inverse groups, [13-12](#), [13-20](#)
 - on remote database, [11-3](#)
- SET_PROG_PRIVS function, [E-66](#)
- SET_ROW_LABEL procedure, [13-12](#)
 - inverse groups, [13-11](#), [13-12](#), [13-19](#), [13-20](#)
- SET_USER_LABELS procedure
 - inverse groups, [13-18](#)
- setting label for database session, [E-78](#)
- shared schema restrictions, [F-21](#)
- SQL*Loader, [12-5](#)
- STRICTLY_DOMINATED_BY function, [B-10](#)
- STRICTLY_DOMINATES function, [B-9](#)
- SYS account
 - policy enforcement, [8-10](#)
- SYS_CONTEXT
 - and labeling functions, [8-12](#)
 - variables, [B-13](#)
- SYSDBA privilege, [10-2](#)
- system privileges, [3-17](#), [3-18](#)

T

- table rows
 - checking if user can read, [E-74](#)
 - checking if user can write to, [E-74](#)
 - SA_UTL.CHECK_READ function, [E-74](#)
 - SA_UTL.CHECK_WRITE function, [E-74](#)
- TO_DATA_LABEL function, [6-16](#), [E-21](#)
- TO_LBAC_DATA_LABEL function, [8-12](#)
- TO_LBAC_DATA_LABEL function, example of using, [E-78](#)
- triggers, [8-12](#)
- trusted program units
 - about, [5-15](#)
- trusted stored program units
 - creating, [9-3](#)
 - error handling, [9-4](#)
 - example, [9-2](#)
 - executing, [9-4](#)
 - introduction, [9-1](#)
 - privileges, [3-18](#), [9-4](#)
 - re-compiling, [9-4](#)
 - replacing, [9-4](#)

U

- unified audit trail, [10-3](#)
- UPDATE_CONTROL option, [8-4](#), [8-16](#)
- updating labeled data, [8-15](#)
- user authorizations, [E-60](#)
 - adding for compartments, [E-54](#)
 - adding for groups, [E-55](#)
 - altering for compartments, [E-56](#)
 - altering for groups, [E-57](#)
 - compartments, [3-6](#), [5-13](#)
 - dropping for all compartments, [E-58](#)
 - dropping for all groups, [E-59](#)
 - dropping for specified groups, [E-60](#)
 - groups, [3-6](#), [5-14](#)
 - levels, [3-5](#), [5-12](#)
 - removing all OLS privileges from user, [E-61](#)
- row labels
 - default, [3-6](#), [3-7](#), [D-2](#), [E-35](#), [E-46](#), [E-79](#)
- SA_USER_ADMIN.SET_USER_PRIVS
 - procedure, [E-70](#)
 - understanding, [3-4](#), [5-12](#)
- USER_SA_SESSION view, [F-19](#)
- users
 - finding label-specific information of, [F-11](#)
 - finding level-specific information of, [F-12](#)
 - finding policy-specific privileges of, [F-12](#)
 - finding privileges of OLS users, [F-10](#)
 - LBACSYS default user account, [4-4](#)
- utilities
 - SA_UTL package, [E-72](#)

V

- views
 - access mediation, [3-18](#)
 - ALL_SA_AUDIT_OPTIONS, [F-4](#)
 - ALL_SA_COMPARTMENTS, [F-5](#)
 - ALL_SA_GROUPS, [F-6](#)
 - ALL_SA_LABELS, [F-5](#), [F-6](#)
 - ALL_SA_LEVELS, [F-7](#)
 - ALL_SA_POLICIES, [F-7](#)
 - ALL_SA_PROG_PRIVS, [F-8](#)
 - ALL_SA_SCHEMA_POLICIES, [F-8](#)
 - ALL_SA_TABLE_POLICIES, [F-9](#)
 - ALL_SA_USER_LABELS, [F-11](#)
 - ALL_SA_USER_LEVELS, [F-12](#)
 - ALL_SA_USER_PRIVS, [F-12](#)
 - ALL_SA_USERS, [F-10](#)
 - CDB_OLS_STATUS, [F-12](#)
 - DBA_OLS_STATUS, [F-18](#)
 - DBA_SA_AUDIT_OPTIONS, [F-13](#)
 - DBA_SA_COMPARTMENTS, [F-13](#)
 - DBA_SA_DATA_LABELS, [F-13](#)
 - DBA_SA_GROUP_HIERARCHY, [F-14](#)
 - DBA_SA_GROUPS, [F-14](#)
 - DBA_SA_LABELS, [F-15](#)
 - DBA_SA_LEVELS, [F-15](#)
 - DBA_SA_POLICIES, [F-15](#)
 - DBA_SA_PROG_PRIVS, [F-16](#)
 - DBA_SA_SCHEMA_POLICIES, [8-11](#), [F-16](#)
 - DBA_SA_TABLE_POLICIES, [8-11](#), [F-16](#)
 - DBA_SA_USER_COMPARTMENTS, [F-17](#)
 - DBA_SA_USER_GROUPS, [F-17](#)
 - DBA_SA_USER_LABELS, [F-18](#)
 - DBA_SA_USER_LEVELS, [F-18](#)
 - DBA_SA_USER_PRIVS, [F-18](#)
 - DBA_SA_USERS, [F-16](#)

W

- write access
 - algorithm, [3-11](#), [3-15](#)
 - introduction, [3-8](#)
- write label, [3-7](#)
- WRITE_CONTROL option
 - algorithm, [3-11](#)
 - definition, [8-4](#)
 - introduction, [8-8](#)
 - LABEL_UPDATE, [8-8](#)
 - with INSERT, UPDATE, DELETE, [8-8](#)
 - with other options, [8-9](#)
- WRITEACROSS privilege, [3-17](#), [8-3](#), [8-7](#), [8-16](#)
- WRITEDOWN privilege, [3-18](#), [8-3](#), [8-7](#), [8-16](#)
- WRITEUP privilege, [3-16](#), [3-17](#)